



US00D652497S

(12) **United States Design Patent**  
**Troxell et al.**

(10) **Patent No.:** **US D652,497 S**  
(45) **Date of Patent:** **\*\* Jan. 17, 2012**

(54) **AIR FILTER FOR VEHICLE MOTOR**

(75) Inventors: **Ronald C. Troxell**, Clarendon Hills, IL (US); **Kenneth S. Schultz**, Evanston, IL (US); **Roy E. Greenlees**, Lake Forest, IL (US); **Edward J. Sroka**, Waconda, IL (US); **Colin W. Greenlees**, Chicago, IL (US)

(73) Assignee: **R2C Performance Products, LLC.**, Forest Park, IL (US)

(\*\*) Term: **14 Years**

(21) Appl. No.: **29/349,778**

(22) Filed: **Apr. 30, 2010**

(51) **LOC (9) Cl.** ..... **23-04**

(52) **U.S. Cl.** ..... **D23/365**

(58) **Field of Classification Search** ..... D23/365, D23/209, 363, 358, 386, 354, 341, 364, 390; 55/385.3, 502, 497, 506, 505, 521, 495, 422, 55/493, DIG. 30; 210/435, 130, 136, 248, 210/339, 448, 452, 497.1; D32/31; D15/5  
See application file for complete search history.

(56) **References Cited**

**U.S. PATENT DOCUMENTS**

D281,273 S \* 11/1985 Artwick ..... D23/390  
D309,974 S \* 8/1990 Tannous ..... D23/209  
D351,650 S \* 10/1994 Vavra ..... D23/365  
D389,963 S \* 1/1998 Scanlon et al. .... D32/31  
D401,597 S 11/1998 Shelton et al.

D401,942 S 12/1998 Shelton et al.  
D403,414 S 12/1998 Shelton et al.  
D403,416 S 12/1998 Shelton et al.  
D407,808 S \* 4/1999 Nepsund et al. .... D23/365  
D440,294 S \* 4/2001 Bilek ..... D23/365  
D450,826 S \* 11/2001 Song ..... D23/365  
D450,827 S \* 11/2001 Gieseke et al. .... D23/365  
6,348,086 B1 \* 2/2002 Harms et al. .... 55/385.3  
D470,216 S \* 2/2003 Gustafson et al. .... D23/209  
D471,623 S \* 3/2003 Gieseke et al. .... D23/365  
D474,836 S \* 5/2003 Chang ..... D23/365  
6,884,274 B2 \* 4/2005 Niakan et al. .... 55/495

\* cited by examiner

*Primary Examiner* — David Muller

(74) *Attorney, Agent, or Firm* — R. Tracy Crump

(57) **CLAIM**

The ornamental design for an air filter for a vehicle motor, as shown and described.

**DESCRIPTION**

FIG. 1 is a perspective view of the air filter showing our new design;

FIG. 2 is a first side view thereof;

FIG. 3 is a second side view thereof;

FIG. 4 is a top view thereof; and,

FIG. 5 is a bottom view thereof.

The portions and areas shown in broken lines in FIG. 5 form no part of the claimed design.

**1 Claim, 5 Drawing Sheets**

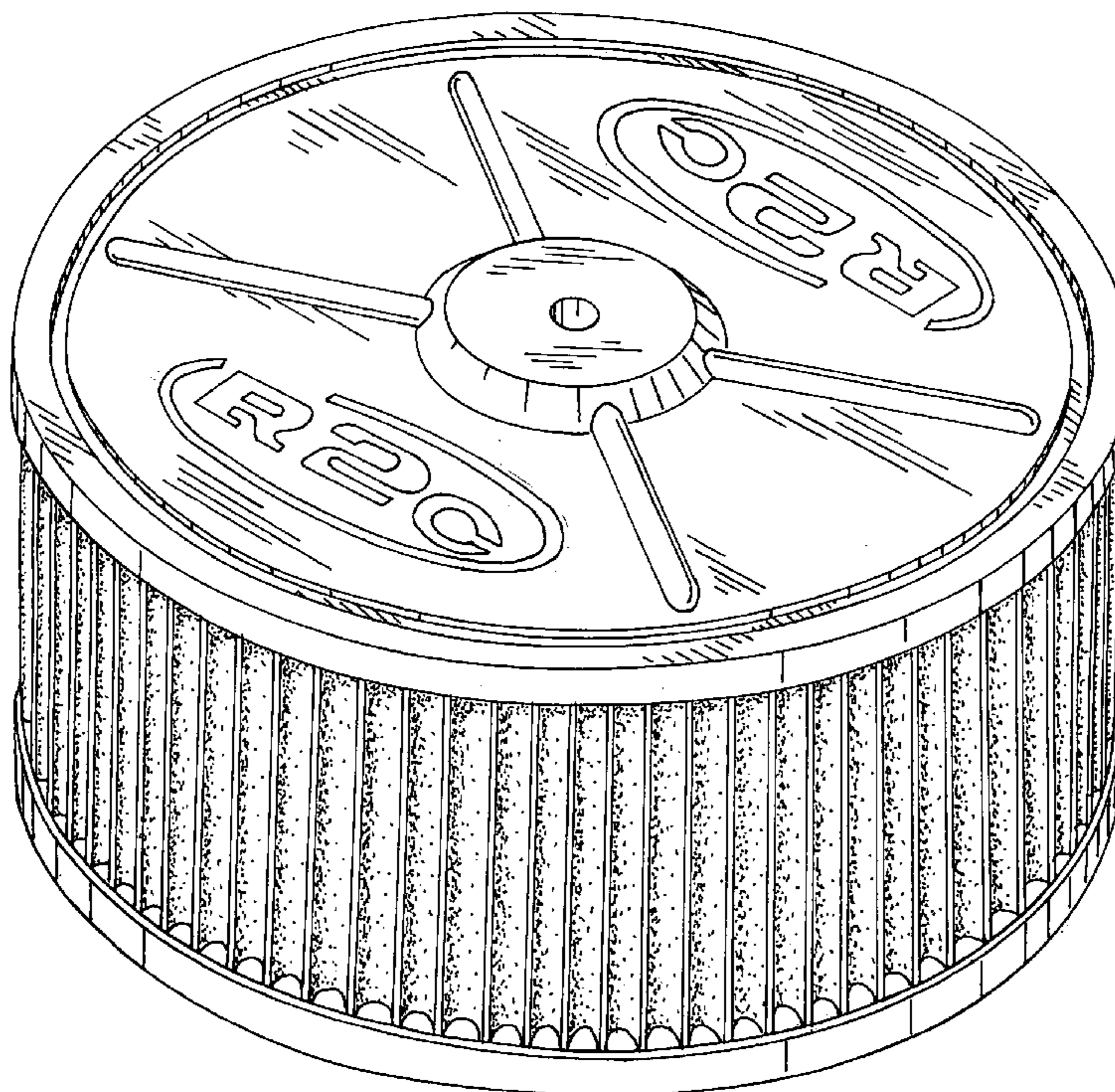

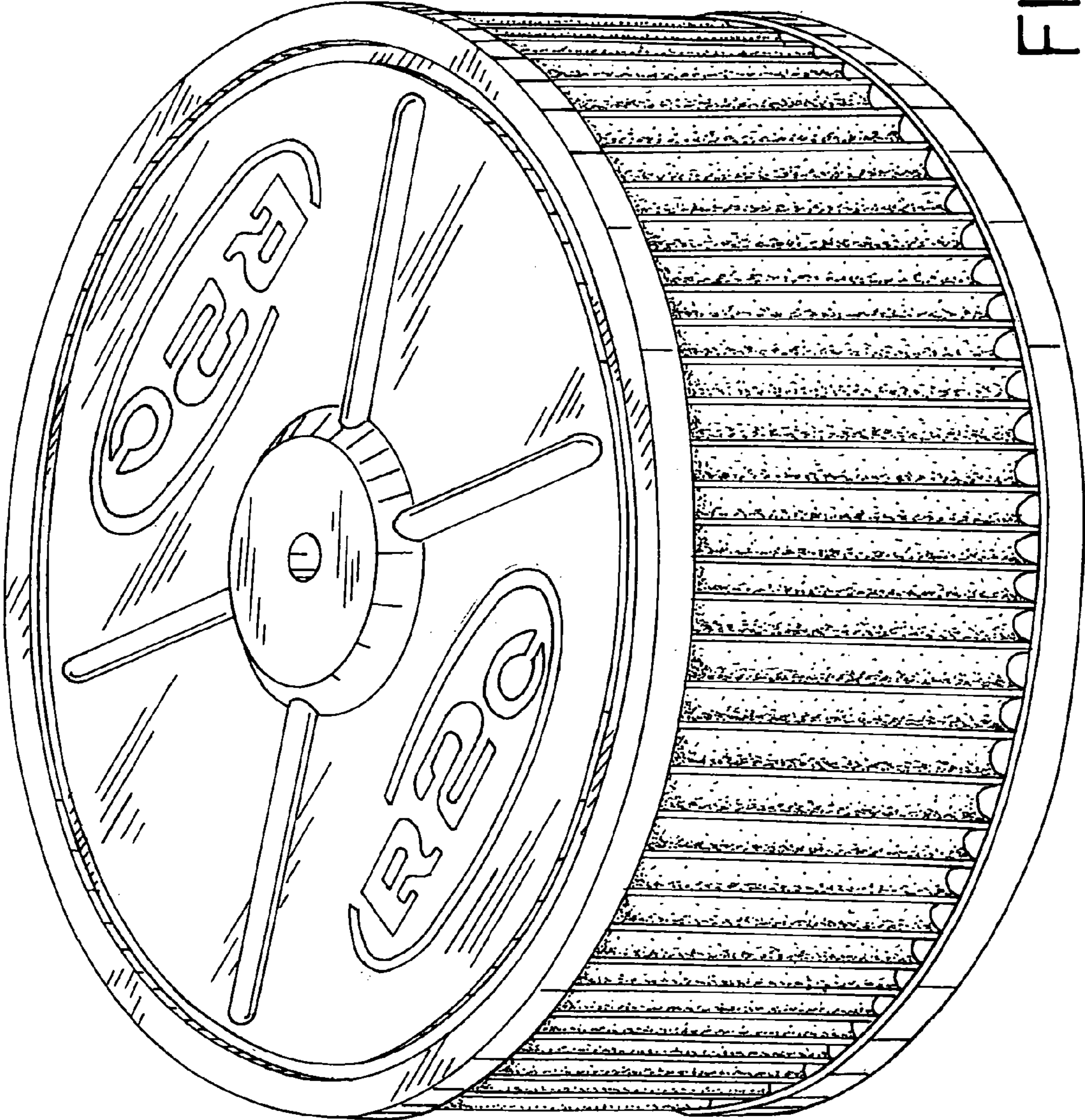

FIG. 1

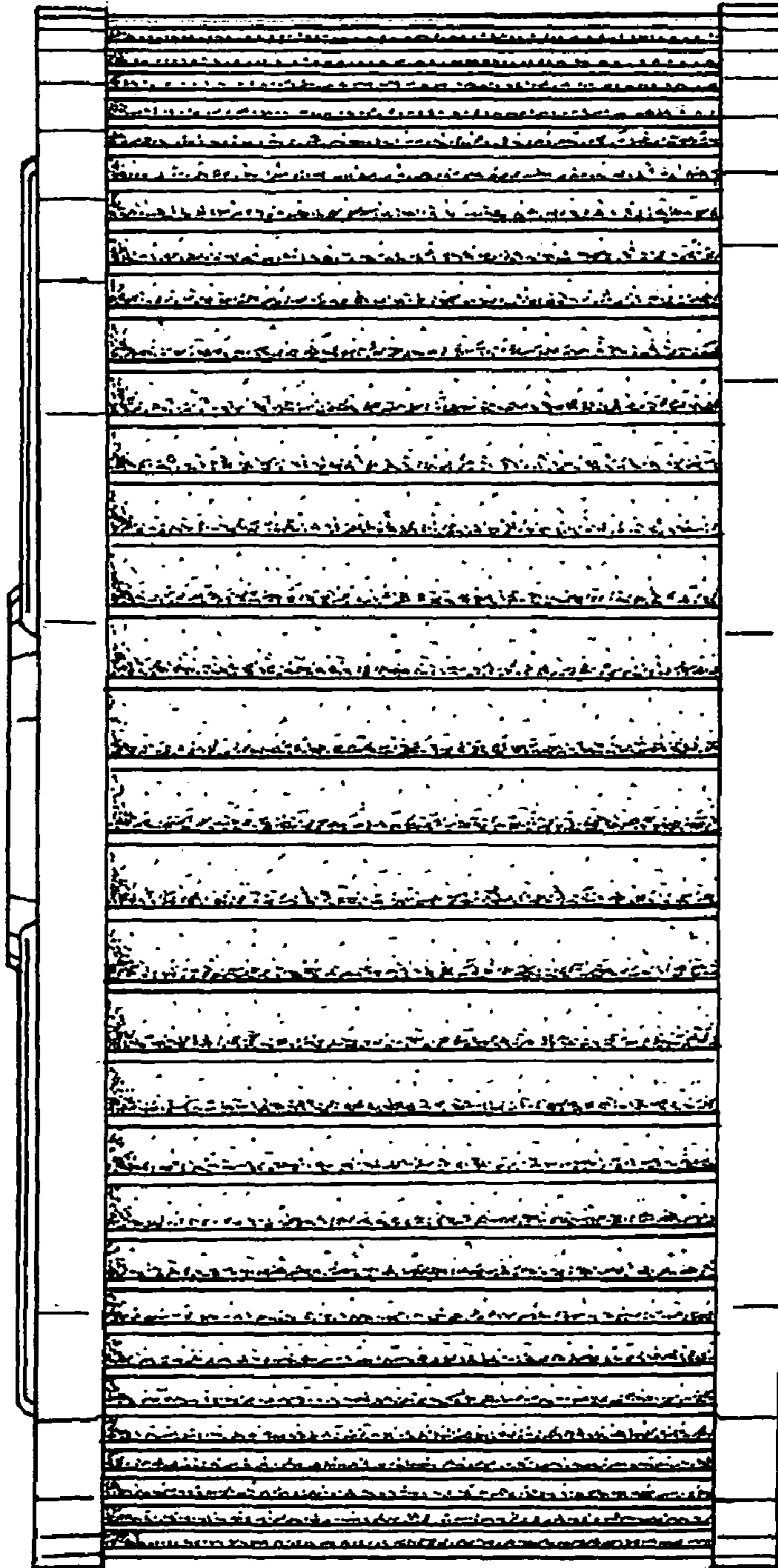

FIG. 2

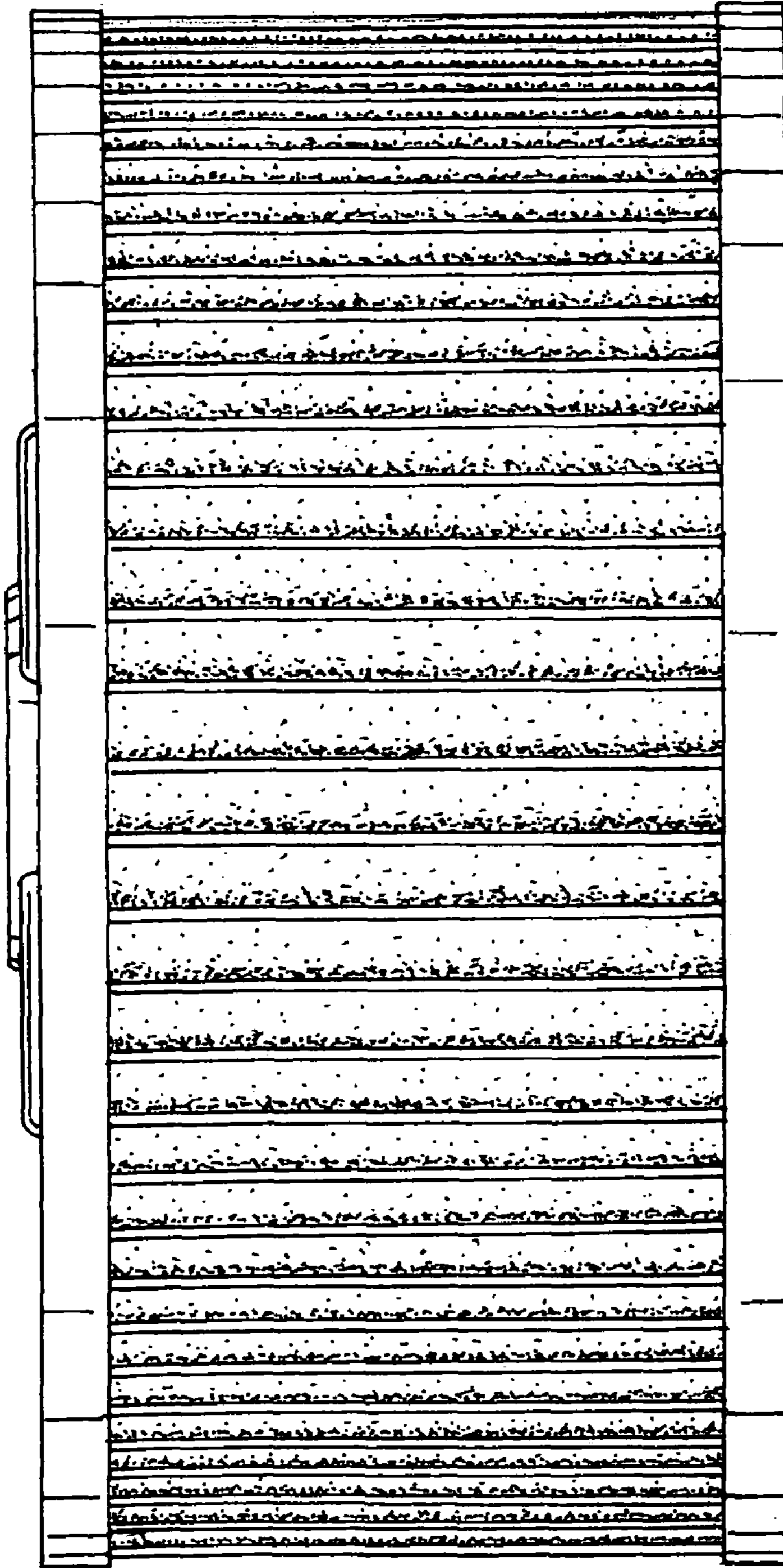

FIG. 3

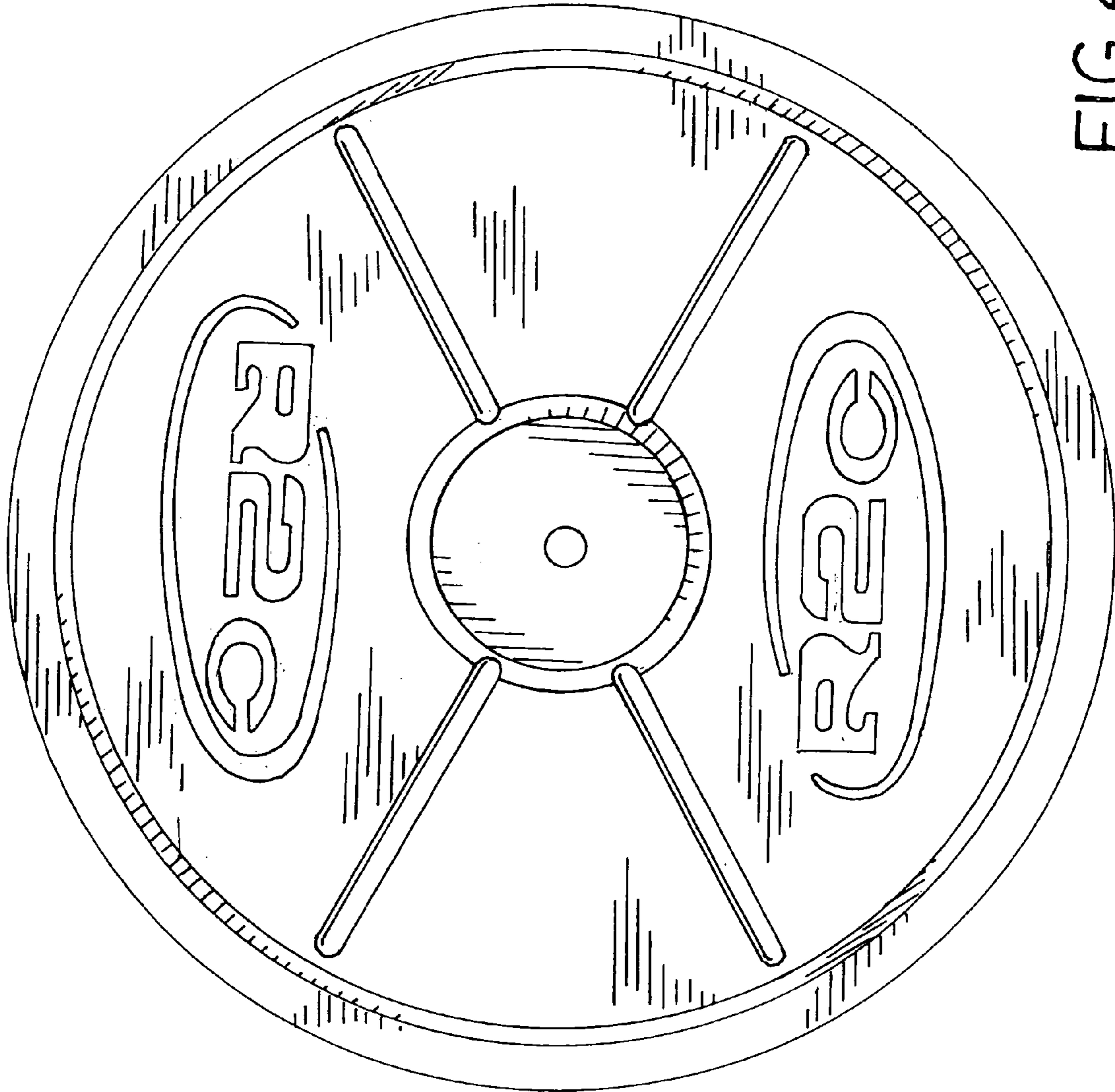

FIG. 4

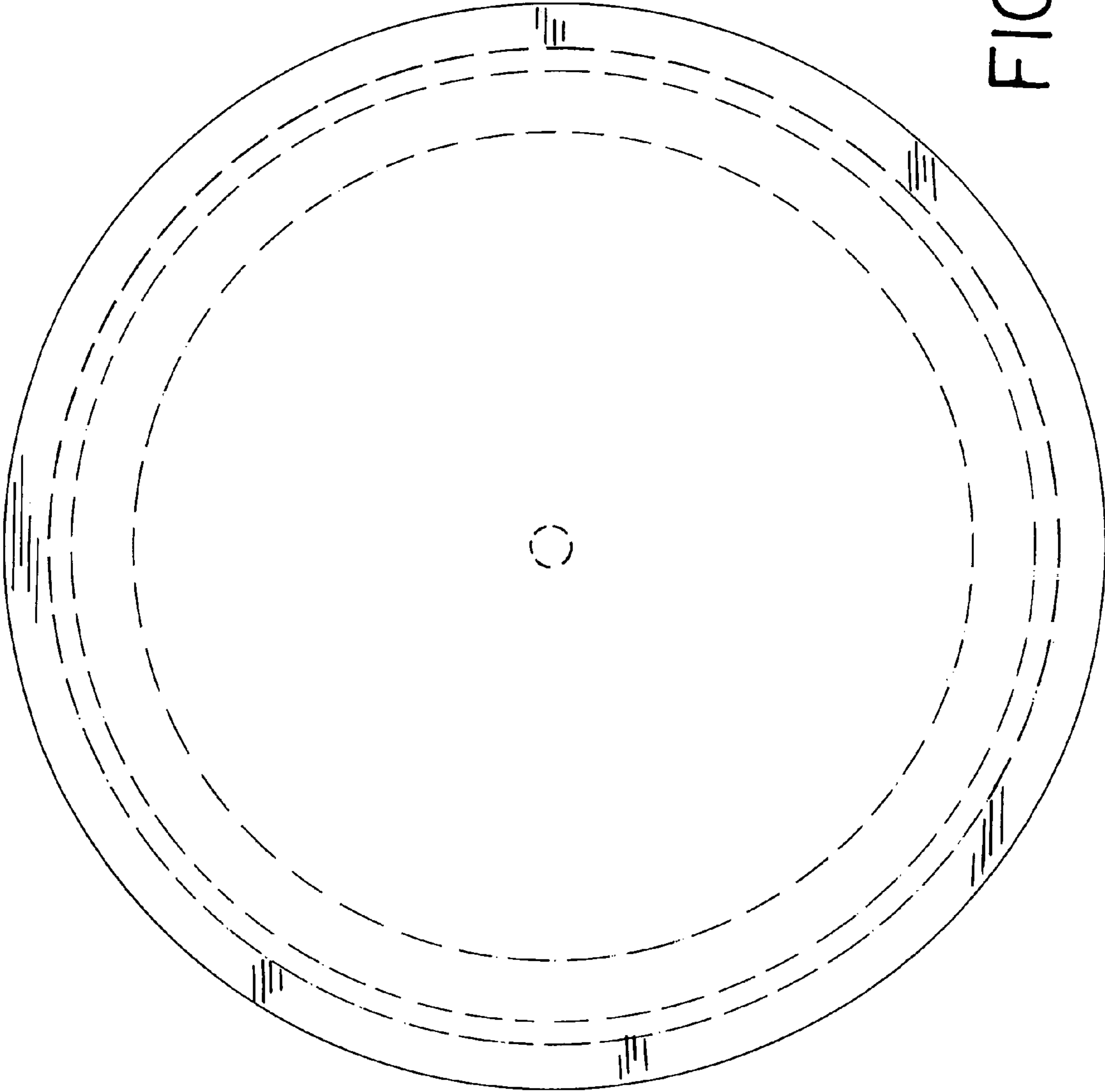

FIG. 5