



US00D652468S

(12) **United States Design Patent**
Burt et al.

(10) **Patent No.:** **US D652,468 S**
(45) **Date of Patent:** **** *Jan. 17, 2012**

(54) **BATTERY ASSIST DEVICE**

(75) Inventors: **Eric C. Burt**, Broomfield, CO (US);
Travis D. Haley, Montrose, CO (US)

(73) Assignee: **Magpul Industries Corp.**, Boulder, CO (US)

(*) Notice: This patent is subject to a terminal disclaimer.

(**) Term: **14 Years**

(21) Appl. No.: **29/341,808**

(22) Filed: **Aug. 12, 2009**

(51) **LOC (9) Cl.** **22-01**

(52) **U.S. Cl.** **D22/108**

(58) **Field of Classification Search** D22/100-116;
D21/572-573; 124/66, 67, 74; 42/51, 71.01,
42/75.01, 75.02, 90, 94; 362/110; 89/40.06,
89/37.04, 33.04, 191.01

See application file for complete search history.

(56) **References Cited**

U.S. PATENT DOCUMENTS

4,429,479	A *	2/1984	Johnson	42/6
D288,279	S *	2/1987	Chesnut	D8/349
5,519,954	A *	5/1996	Garrett	42/6
7,661,219	B1 *	2/2010	Knight et al.	42/70.02

* cited by examiner

Primary Examiner — Michael Pratt

(74) *Attorney, Agent, or Firm* — Geoffrey E. Dobbin

(57) **CLAIM**

The ornamental design for the battery assist device, as shown and described.

DESCRIPTION

FIG. 1 is a right elevation of the battery assist device, with an attached bolt catch shown in broken lines.

FIG. 2 is a left elevation of the battery assist device of FIG. 1. FIG. 3 is an upper right perspective view of the battery assist device of FIG. 1.

FIG. 4 is an exploded right elevation of the battery assist device, with associated mounting hardware shown in broken lines

FIG. 5 is an exploded left elevation of the battery assist device of FIG. 4.

FIG. 6 is an exploded upper/right/front perspective view of the battery assist device of FIG. 4.

FIG. 7 is an exploded rear elevation of the battery assist device of FIG. 4.

FIG. 8 is an exploded front elevation of the battery assist device of FIG. 4.

FIG. 9 is an exploded top plan view of the battery assist device of FIG. 4.

FIG. 10 is an exploded bottom plan view of the battery assist device of FIG. 4.

FIG. 11 is an exploded upper/left/rear perspective view of the battery assist device of FIG. 4.

FIG. 12 is an exploded bottom/left/rear perspective view of the battery assist device of FIG. 4.

FIG. 13 is an exploded bottom/right/rear perspective view of the battery assist device of FIG. 4.

FIG. 14 is an exploded upper/right/rear perspective view of the battery assist device of FIG. 4.

FIG. 15 is an exploded bottom/right/front perspective view of the battery assist device of FIG. 4.

FIG. 16 is an exploded bottom/left/front perspective view of the battery assist device of FIG. 4; and,

FIG. 17 is an exploded upper/left/front perspective view of the battery assist device of FIG. 4.

The broken lines in the figures depict a bolt catch and associated mounting hardware and are illustrative of environment and not intended to form a part of the claimed design.

1 Claim, 5 Drawing Sheets

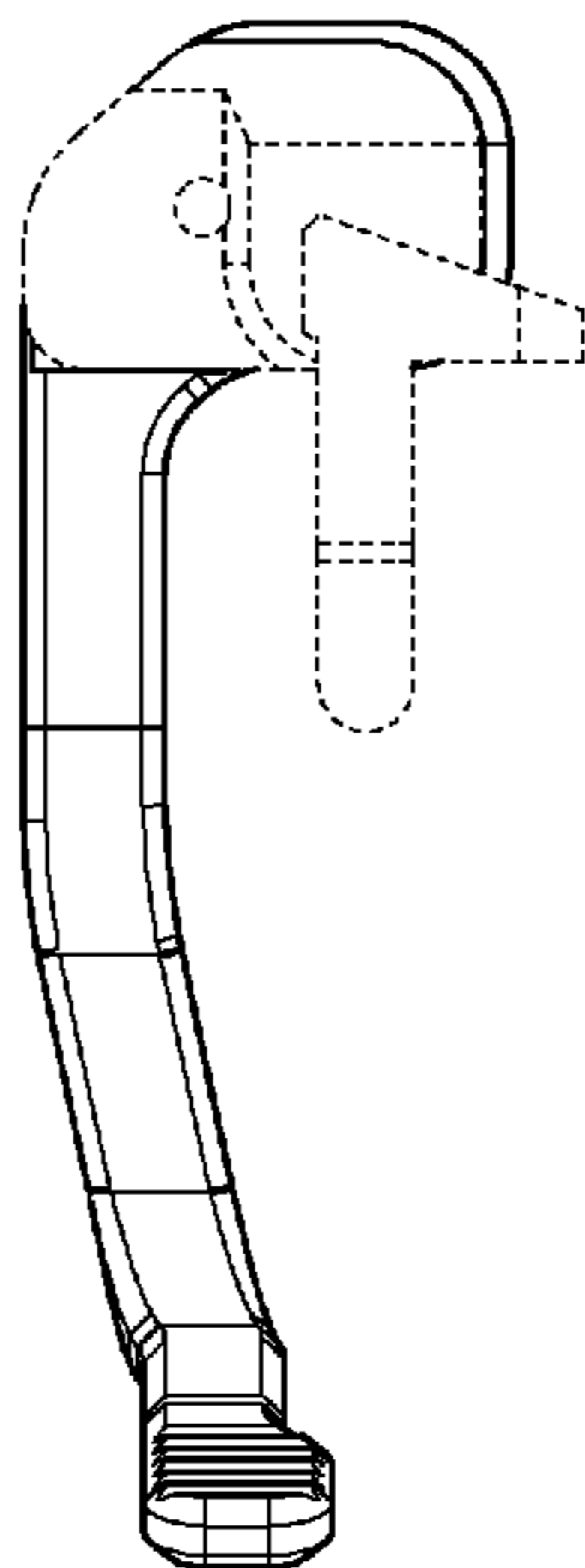

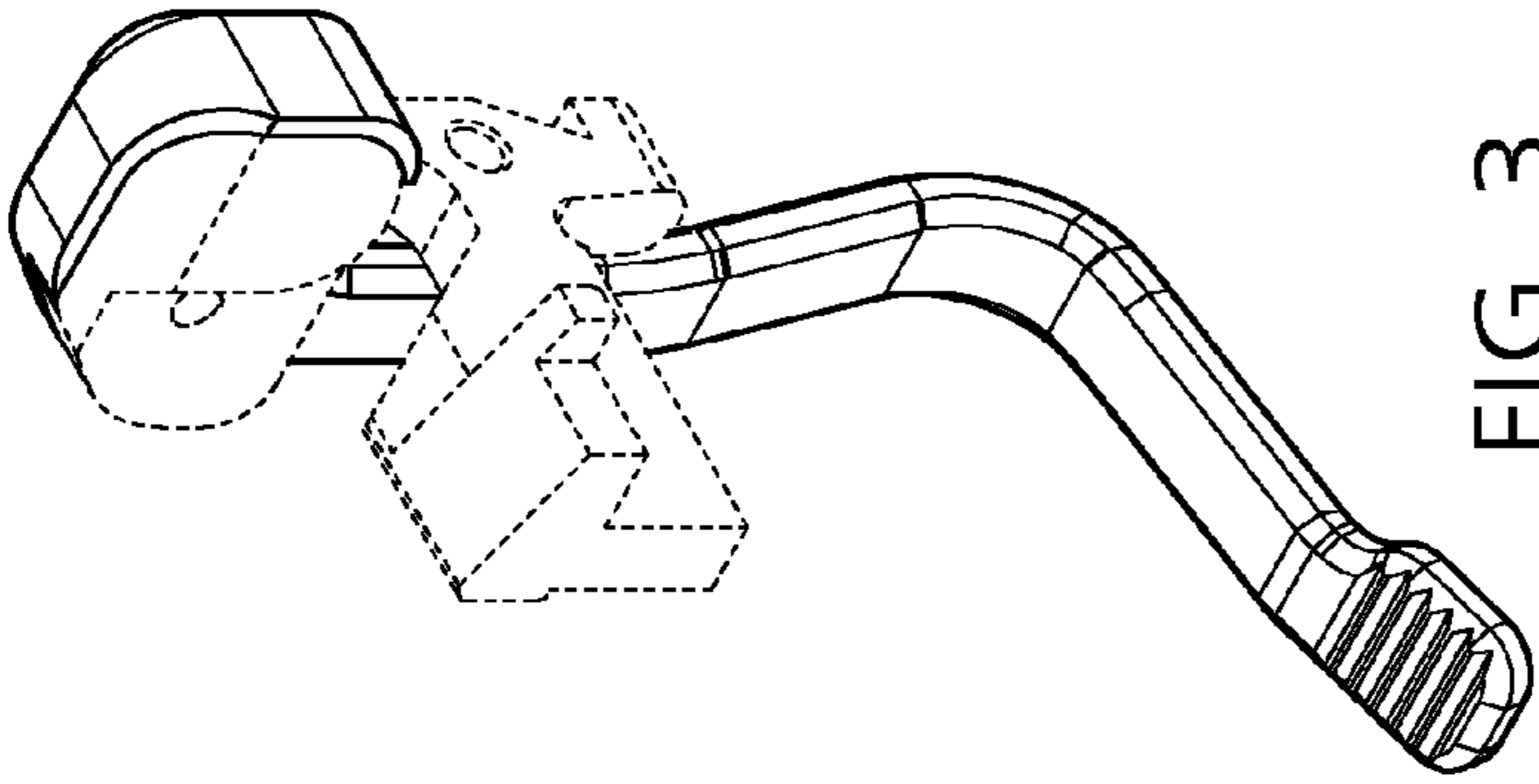

FIG. 3

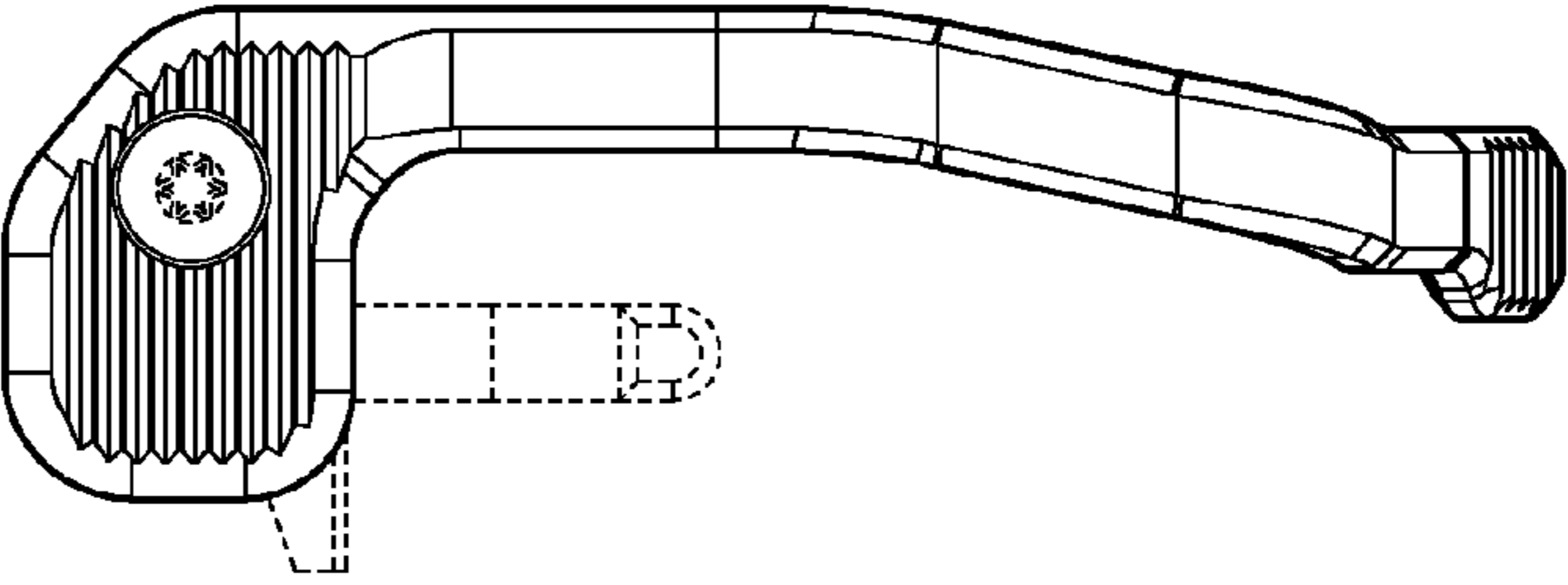

FIG. 2

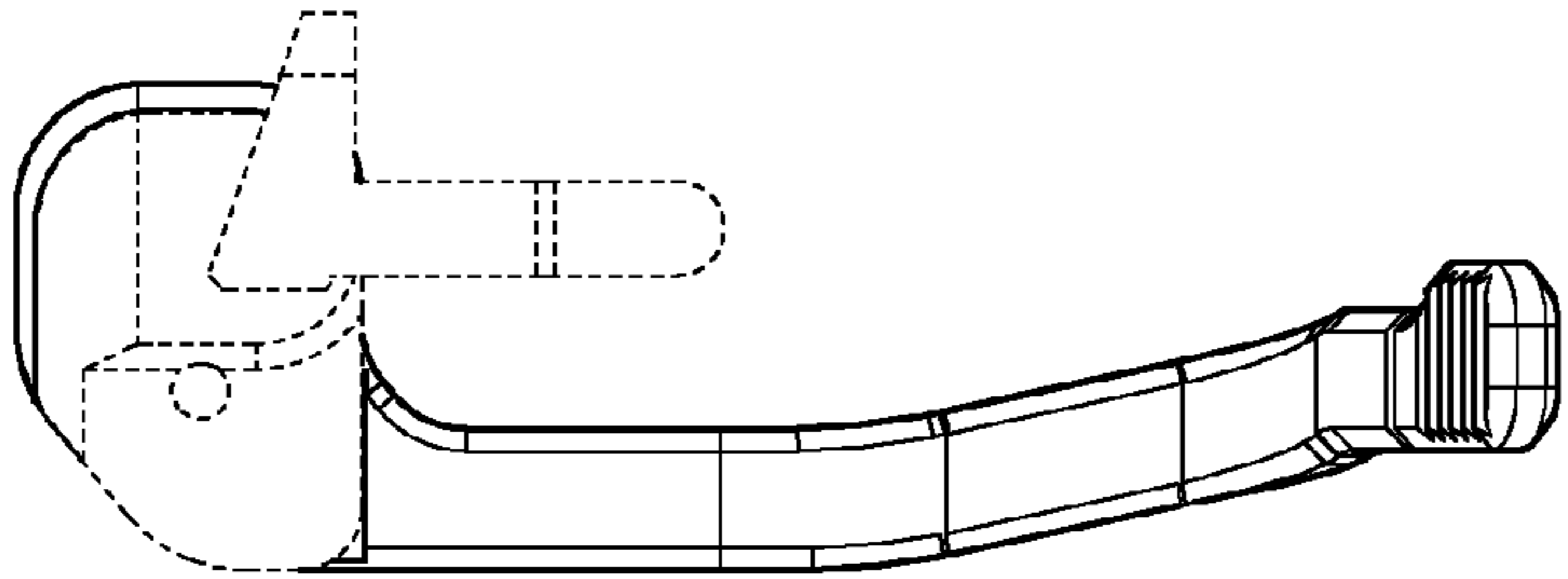

FIG. 1

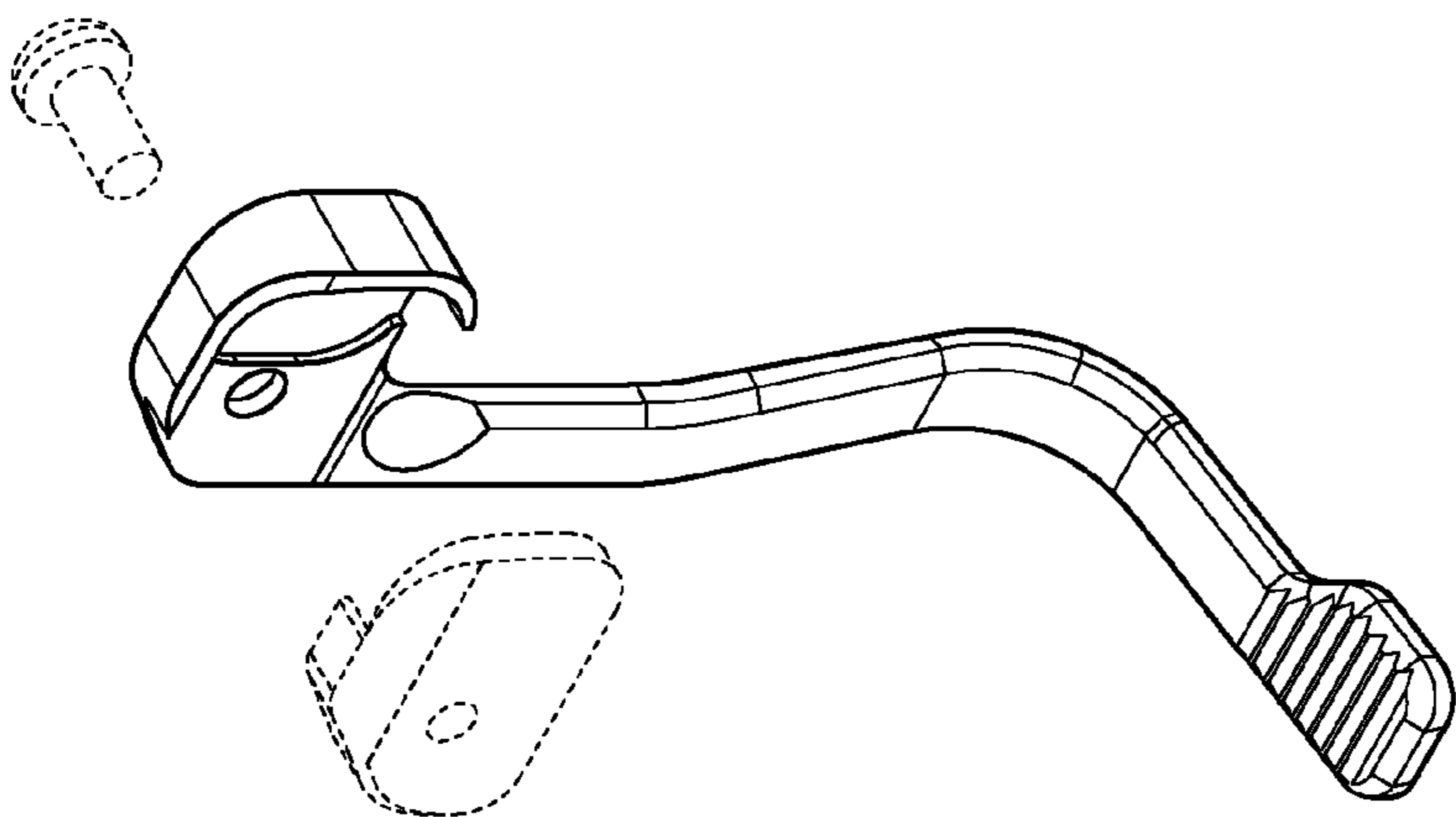

FIG. 6

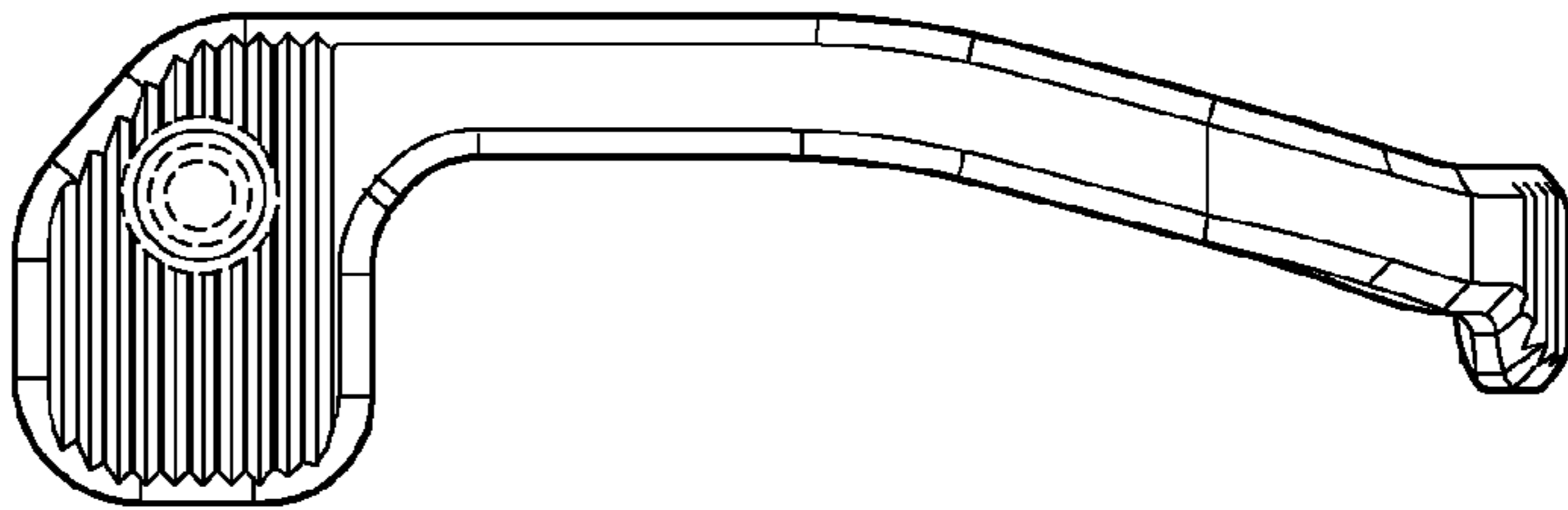

FIG. 5

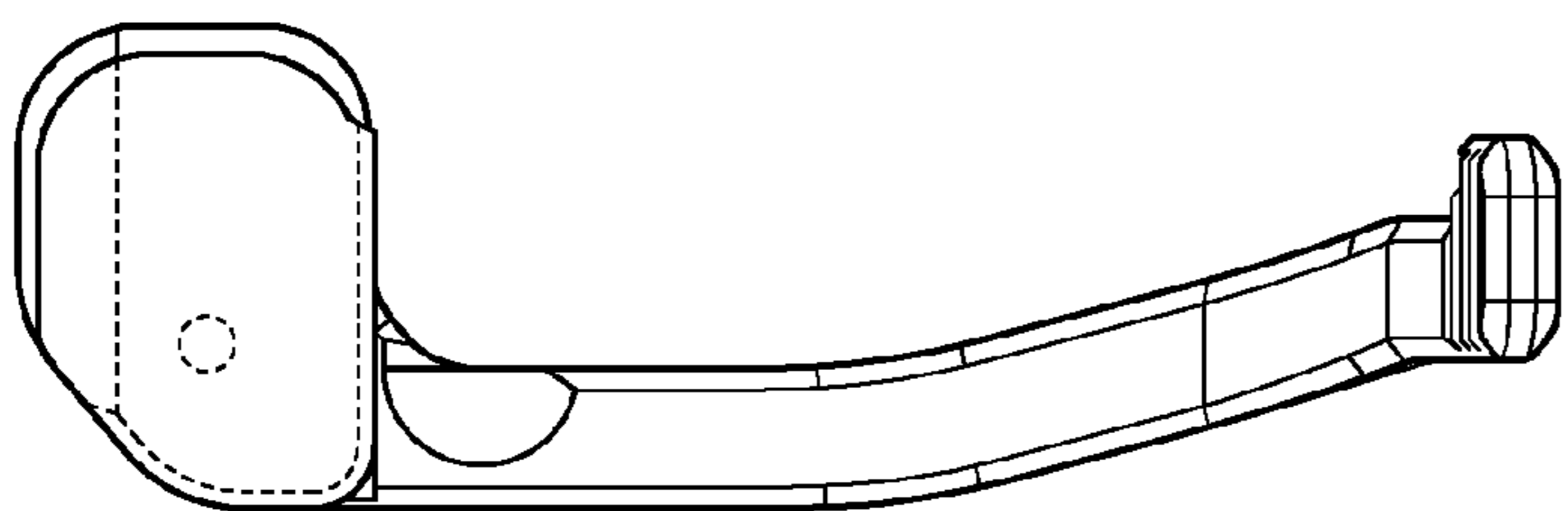

FIG. 4

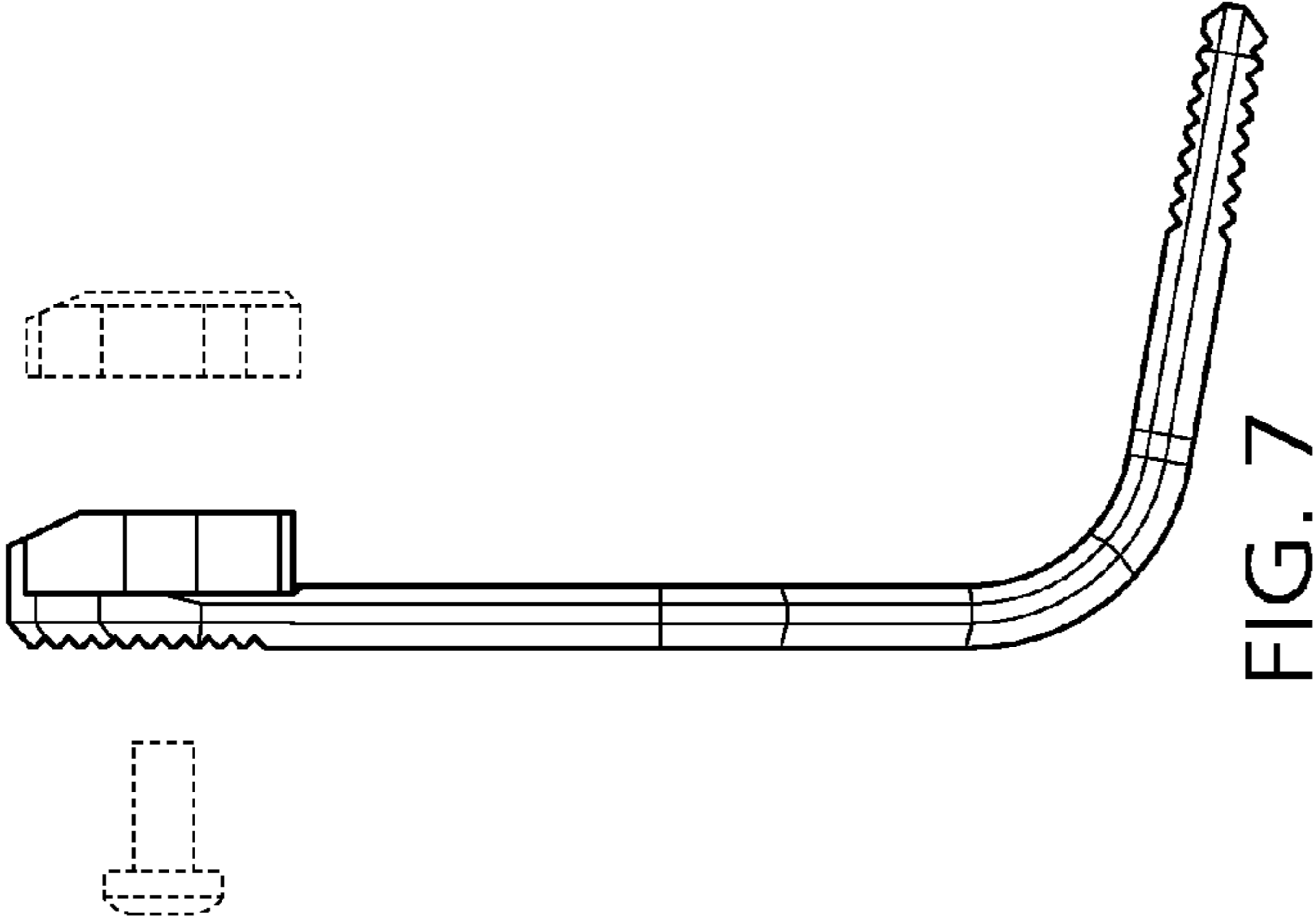

FIG. 7

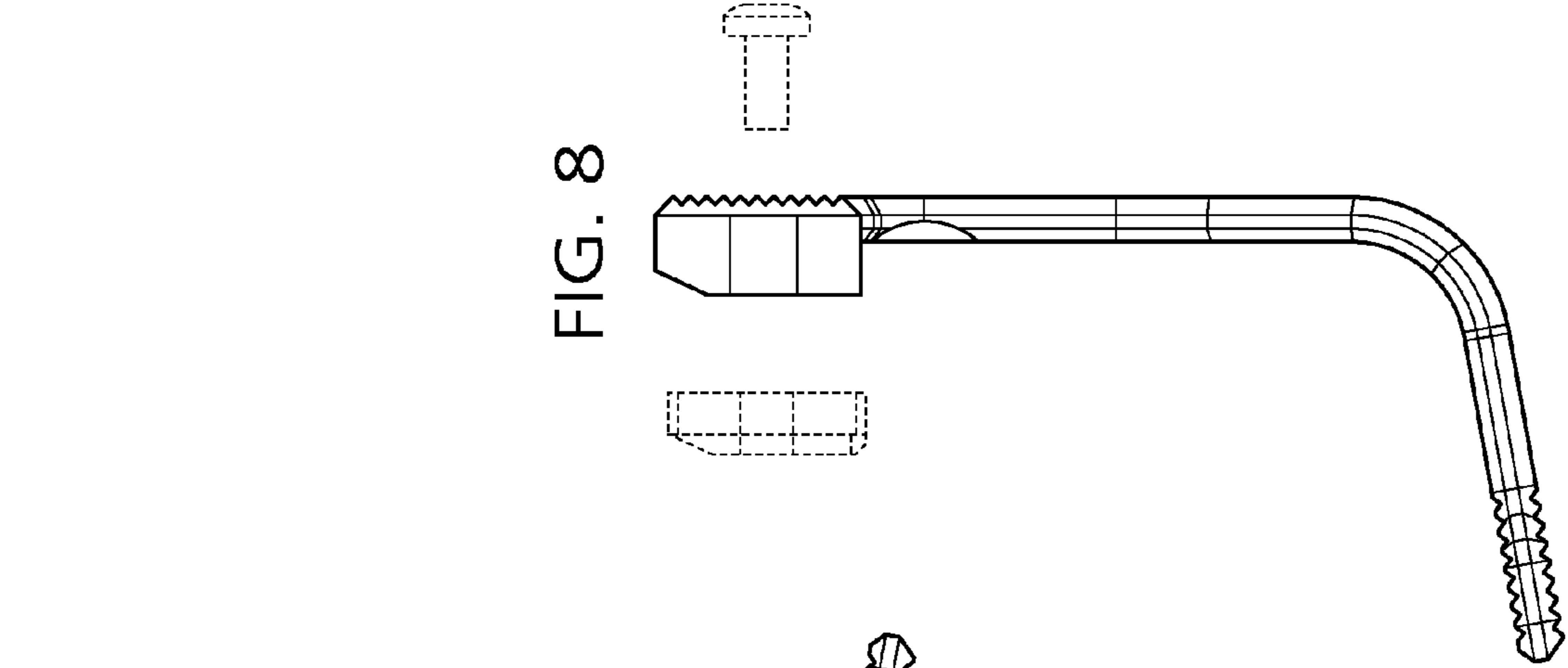

FIG. 8

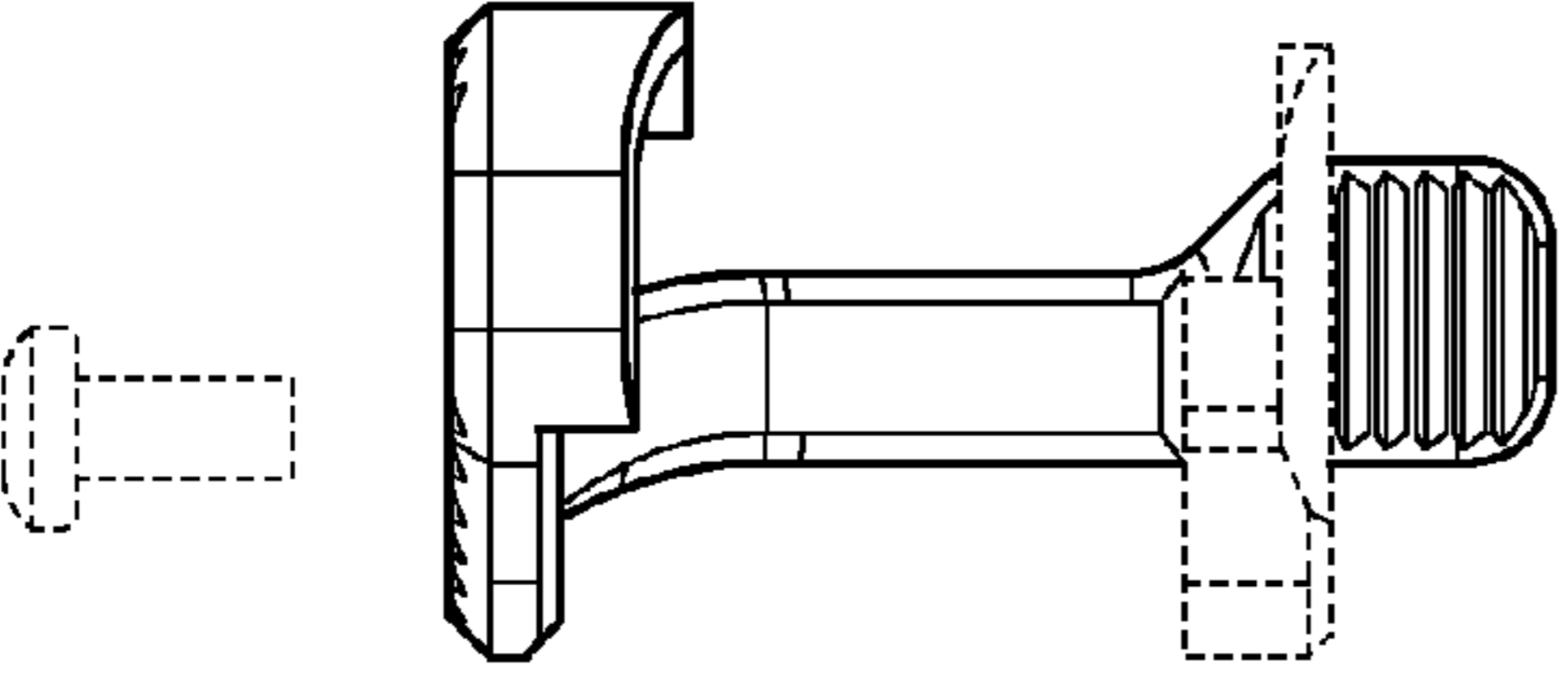

FIG. 9

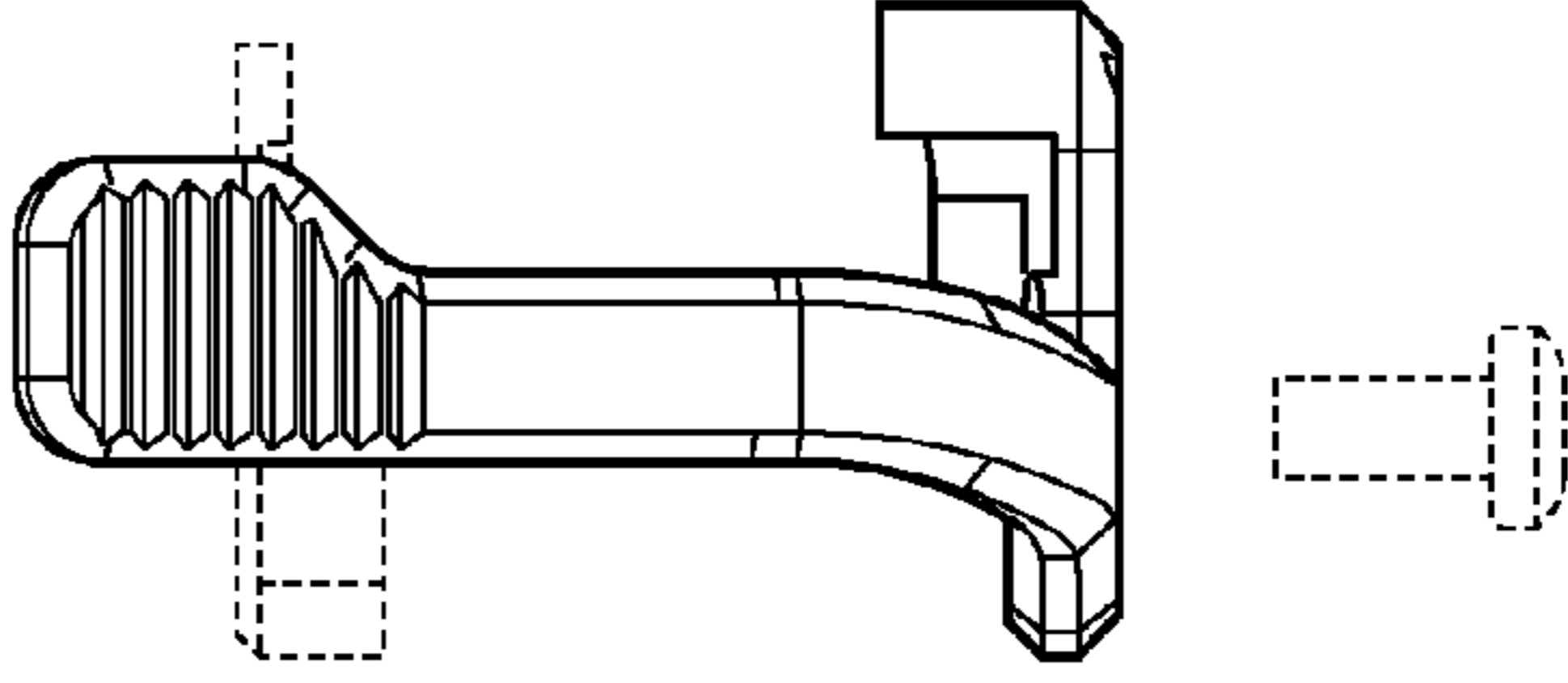
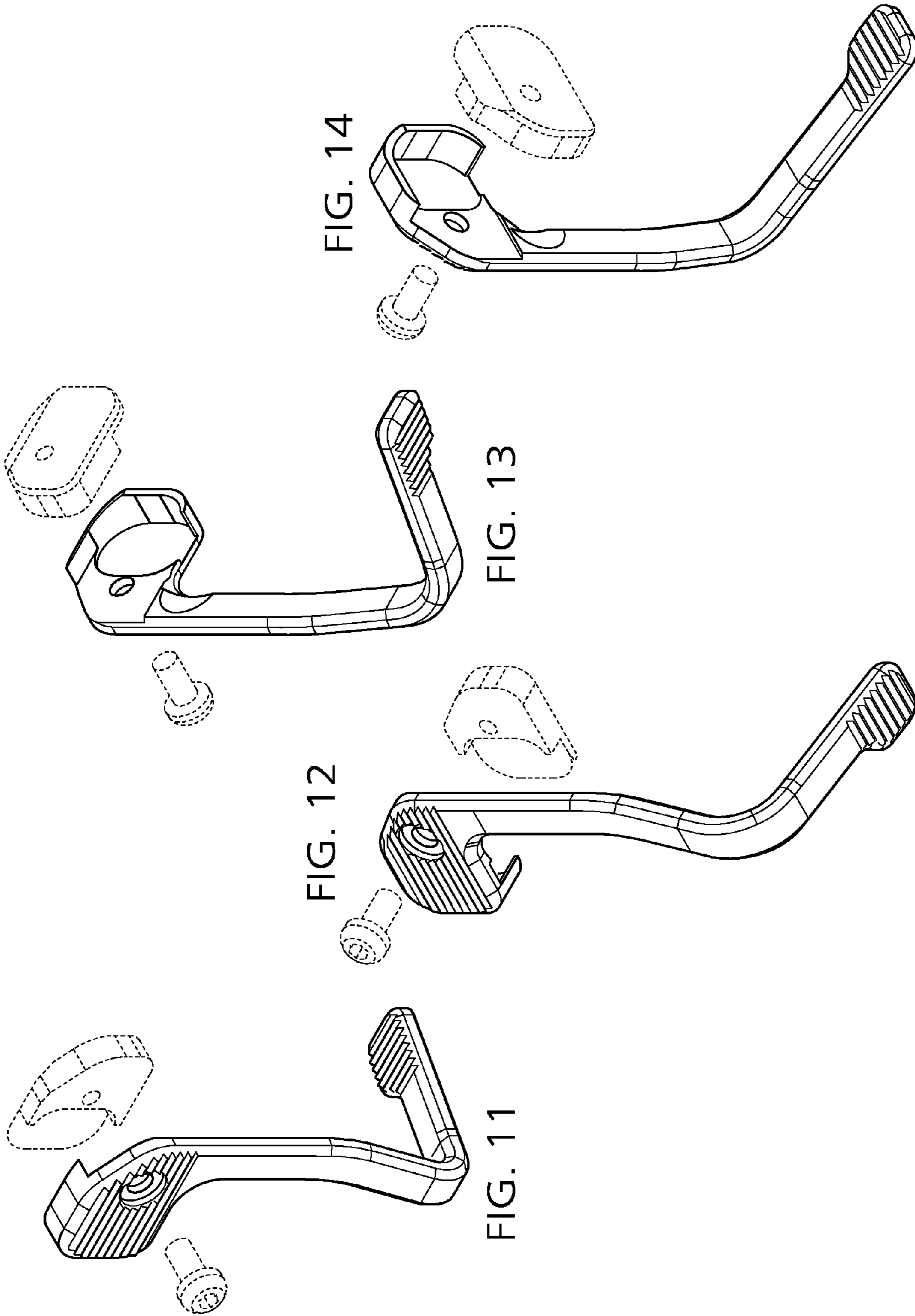

FIG. 10



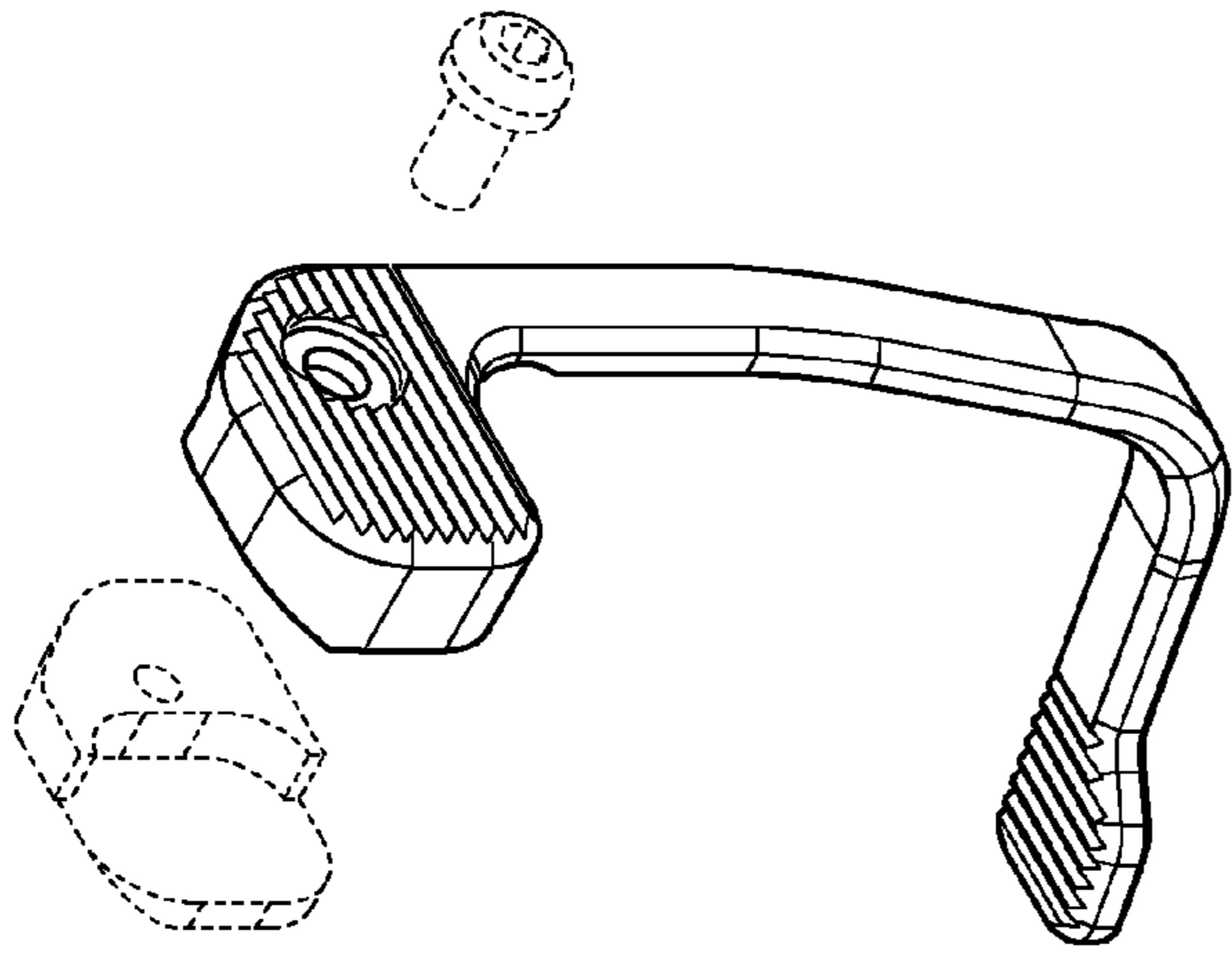

FIG. 15

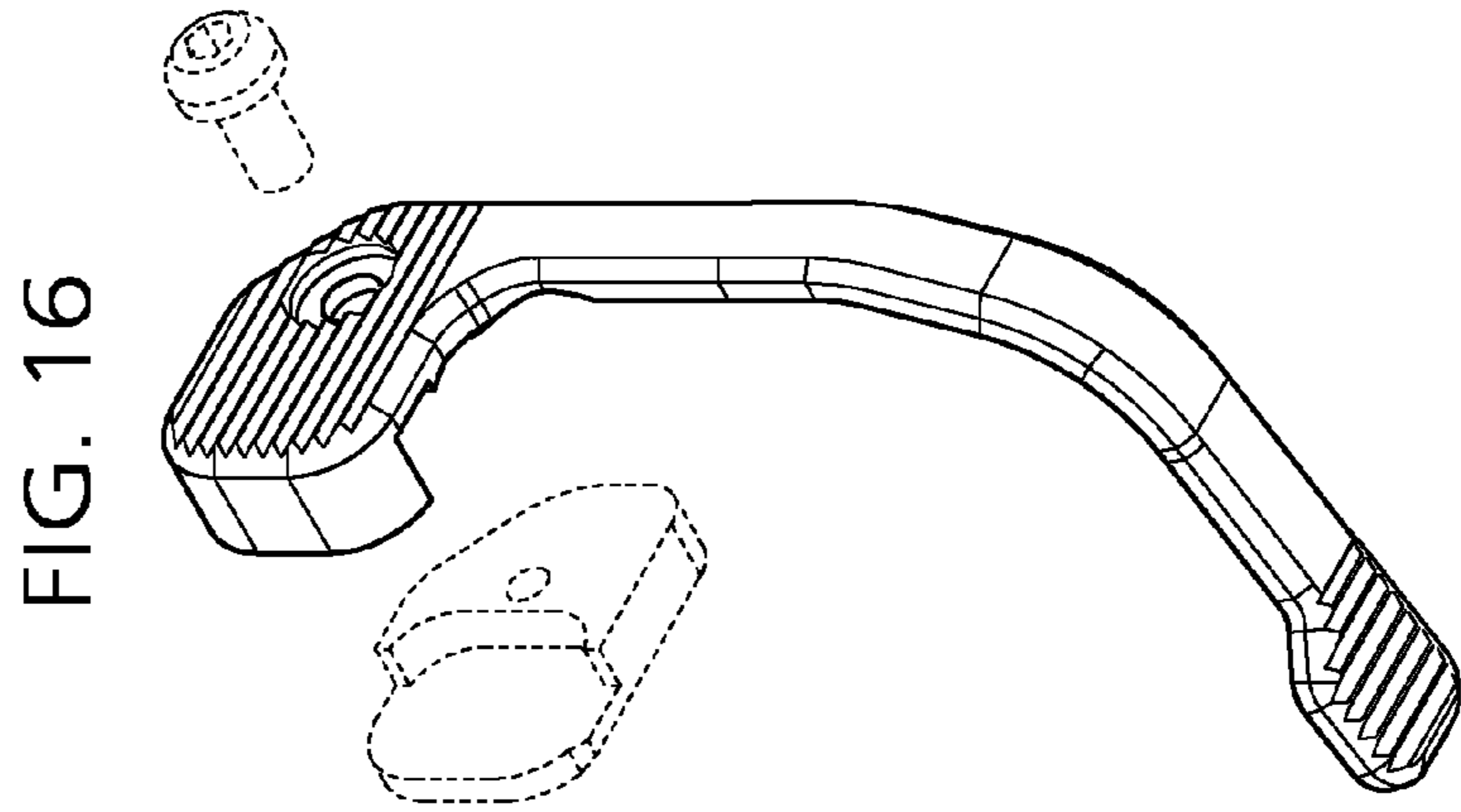

FIG. 16

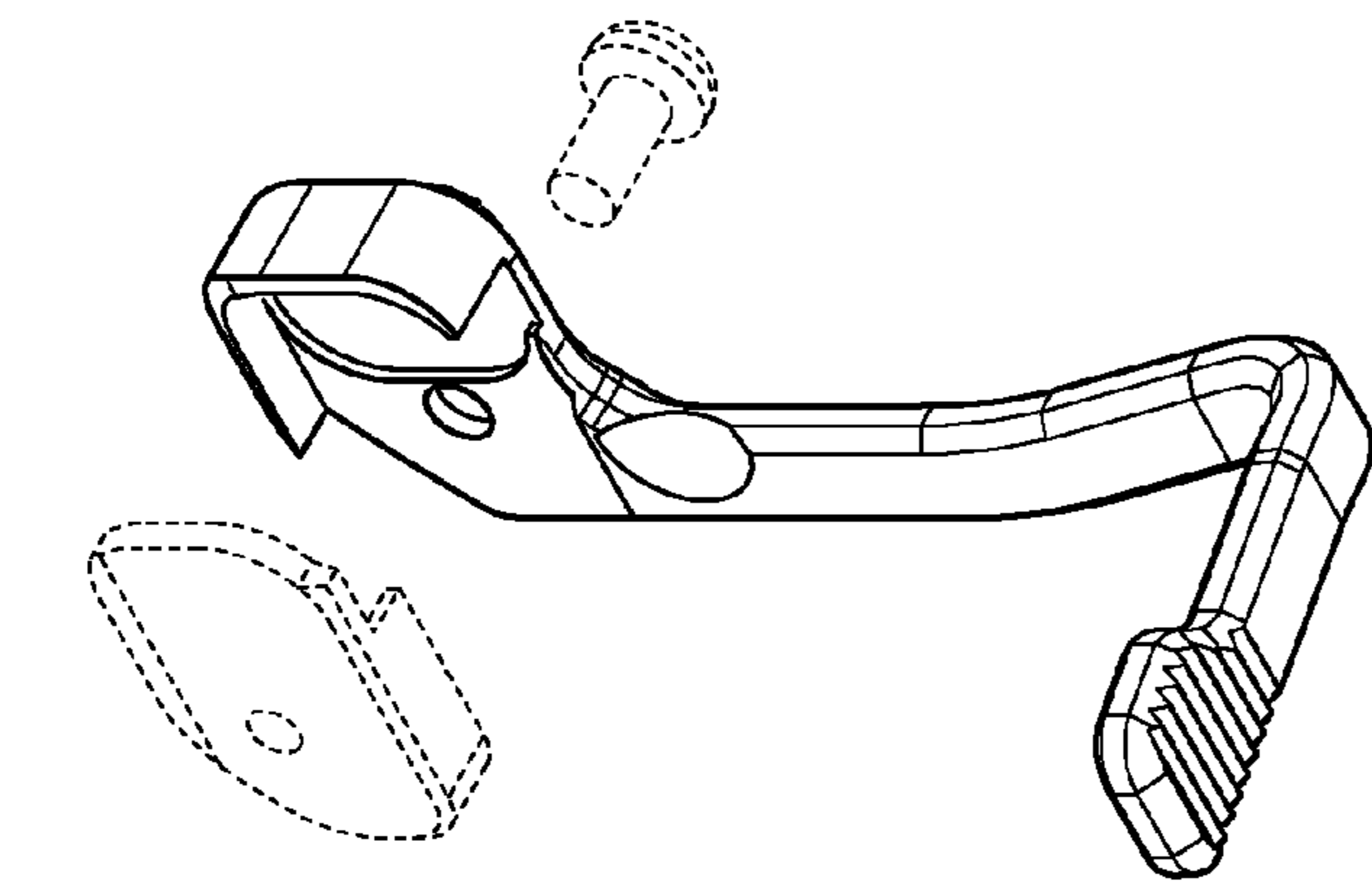

FIG. 17