



US00D652216S

(12) **United States Design Patent**
Fair

(10) **Patent No.:** **US D652,216 S**

(45) **Date of Patent:** **** Jan. 17, 2012**

(54) **LUGGAGE WITH WHEELS AND RAISED RAILS**

(75) Inventor: **Paul Fair**, Denver, CO (US)

(73) Assignee: **Thule Organization Solutions, Inc.**,
Longmont, CO (US)

(**) Term: **14 Years**

(21) Appl. No.: **29/354,481**

(22) Filed: **Jan. 25, 2010**

(51) **LOC (9) Cl.** **03-01**

(52) **U.S. Cl.** **D3/318**

(58) **Field of Classification Search** D3/318,
D3/272-273, 279, 282-283; 190/18 A, 18 R,
190/24, 39, 115, 117, 119
See application file for complete search history.

(56) **References Cited**

U.S. PATENT DOCUMENTS

2,912,080	A *	11/1959	Ikelheimer	190/127
D245,815	S *	9/1977	Dunnavan	D3/282
4,911,348	A *	3/1990	Rasor et al.	224/321
4,988,026	A *	1/1991	Rasor et al.	224/321
D354,398	S *	1/1995	Berman	D3/276
5,636,776	A *	6/1997	Rak et al.	224/322

D382,114	S *	8/1997	Dickinson et al.	D3/279
6,286,645	B1 *	9/2001	Chen	190/125
D454,430	S *	3/2002	Sijmons	D3/279
D463,909	S *	10/2002	Carter	D3/279
D479,651	S *	9/2003	Shen	D3/279
D563,101	S *	3/2008	Kuchler	D3/279
D587,902	S *	3/2009	Yoneno	D3/279

* cited by examiner

Primary Examiner — Holly Baynham

(74) *Attorney, Agent, or Firm* — Sheridan Ross P.C.

(57) **CLAIM**

The ornamental design for luggage with wheels and raised rails, as shown and described.

DESCRIPTION

FIG. 1 is a perspective view of the raised rails for the outer surface of luggage;

FIG. 2 is a front elevation view thereof;

FIG. 3 is a left elevation view thereof;

FIG. 4 is a right elevation view thereof;

FIG. 5 is a top plan view thereof; and,

FIG. 6 is a bottom plan view thereof.

The broken line showing of a suitcase and portions thereof is included for the purpose of illustrating environment and forms no part of the claimed design.

1 Claim, 2 Drawing Sheets

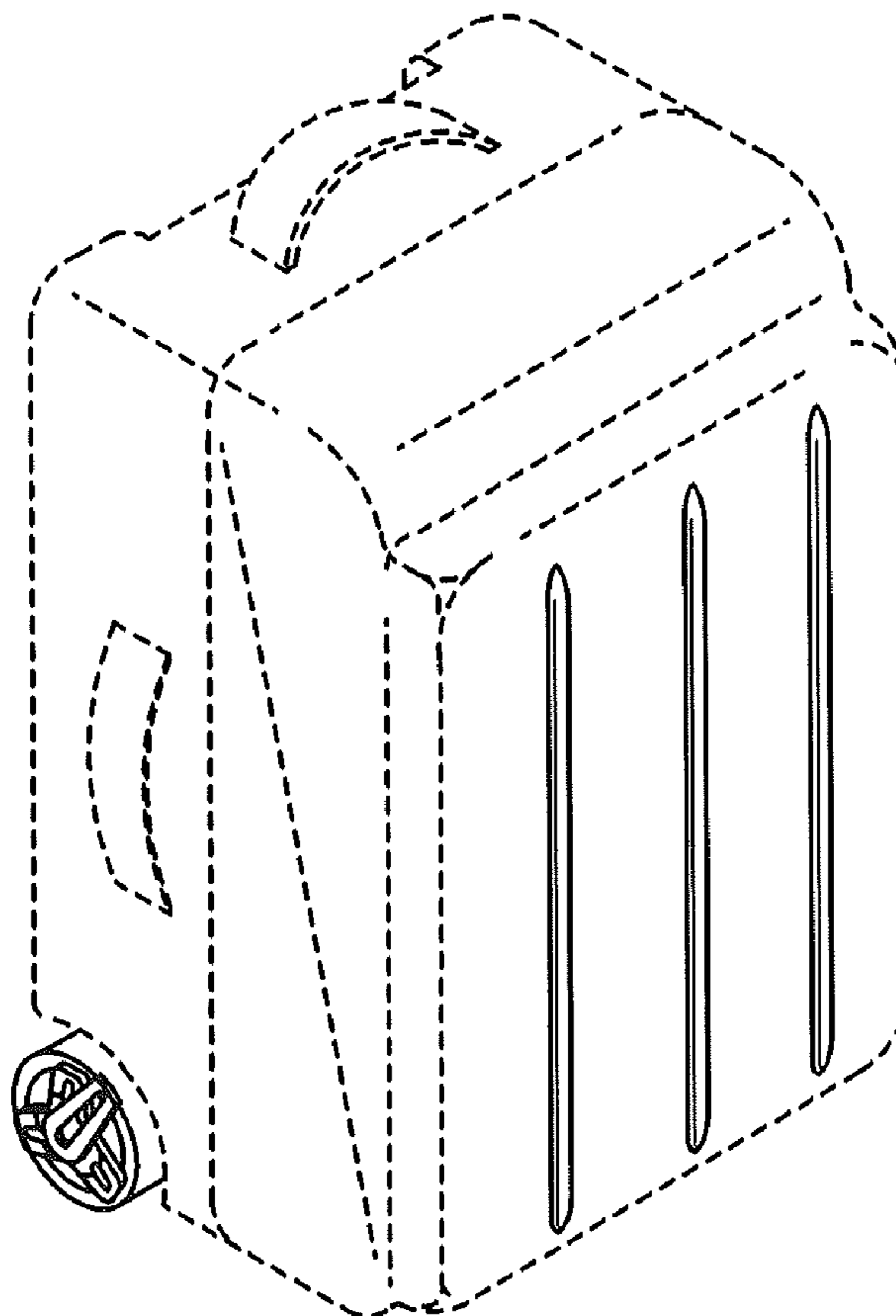

Fig. 1

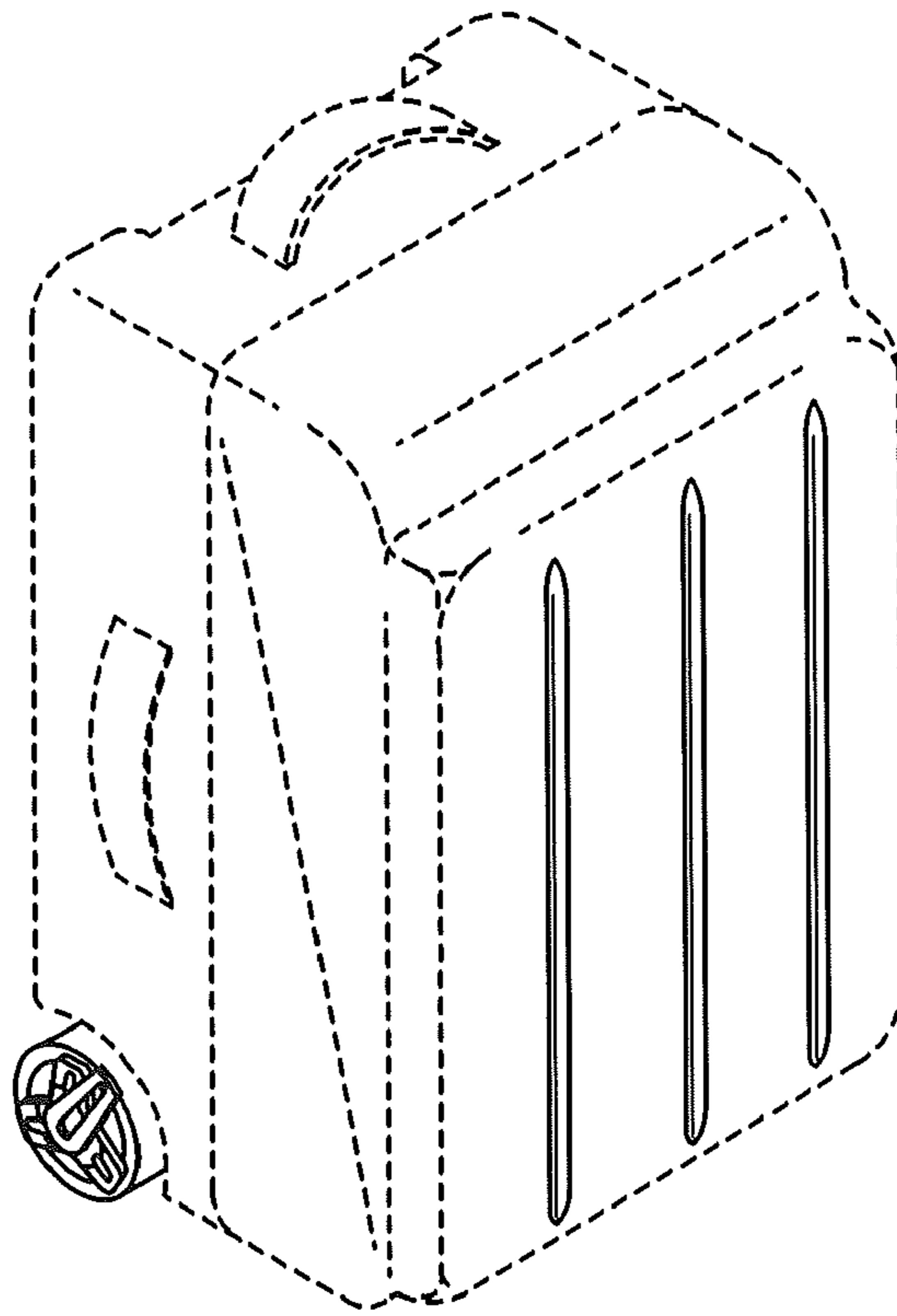
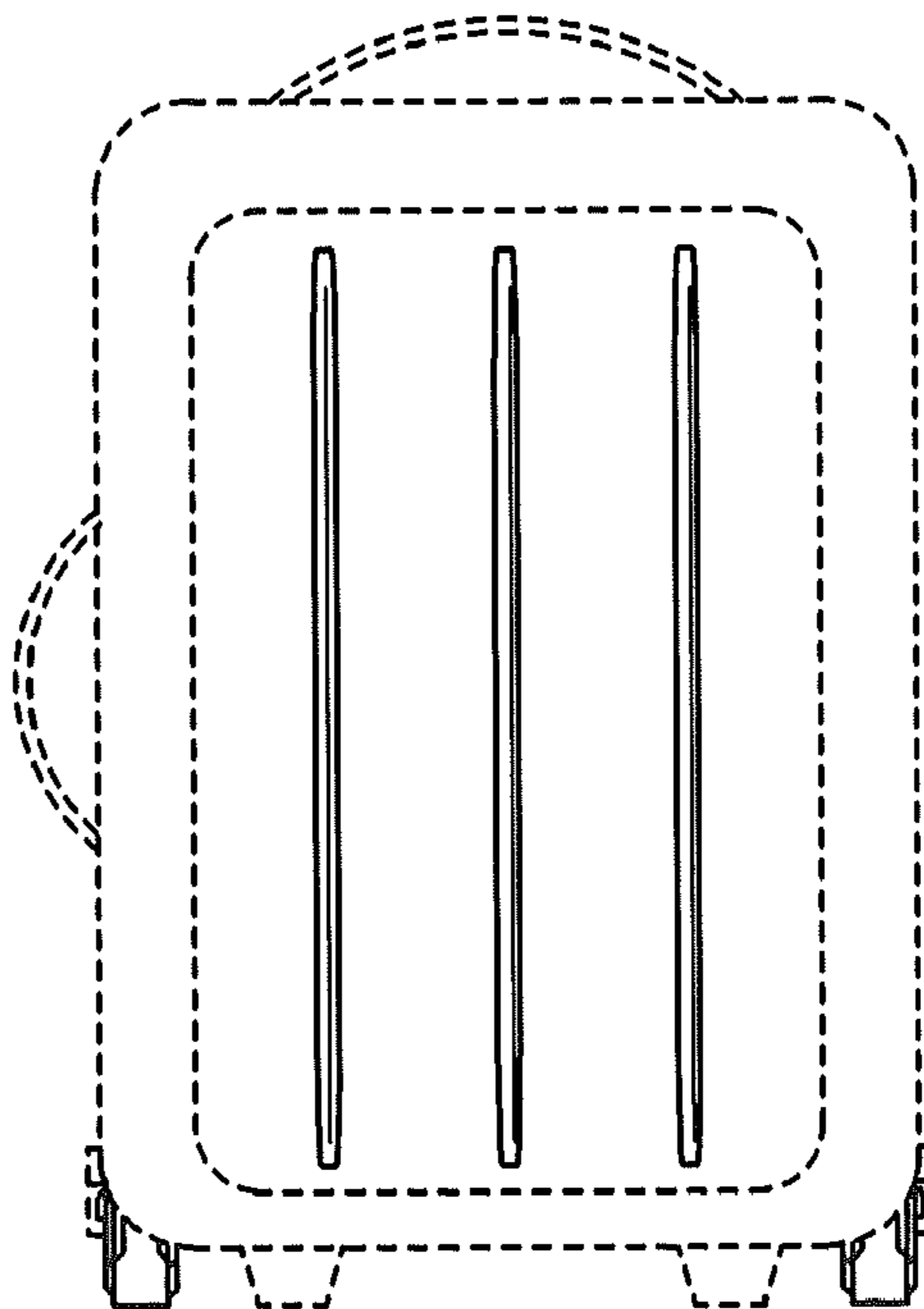

Fig. 2



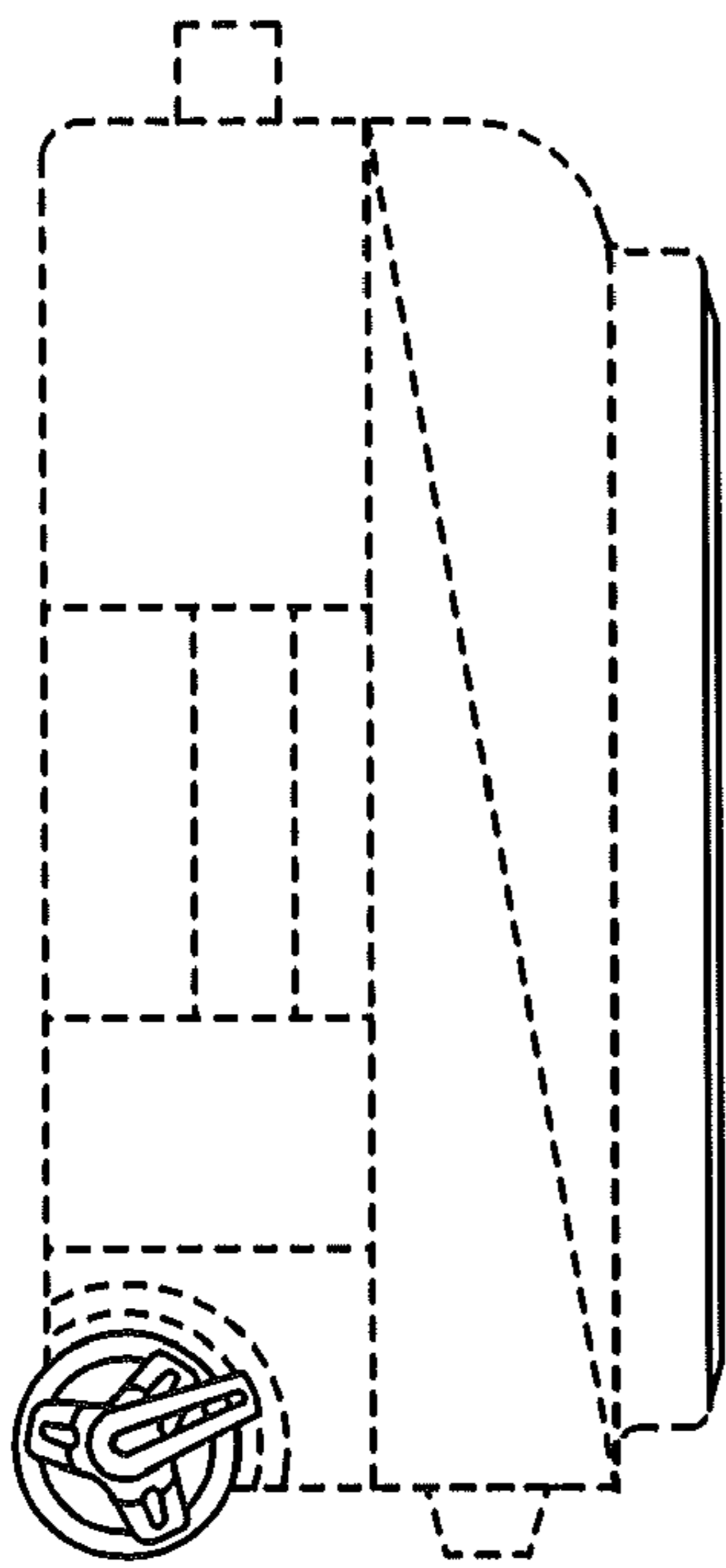

Fig. 3

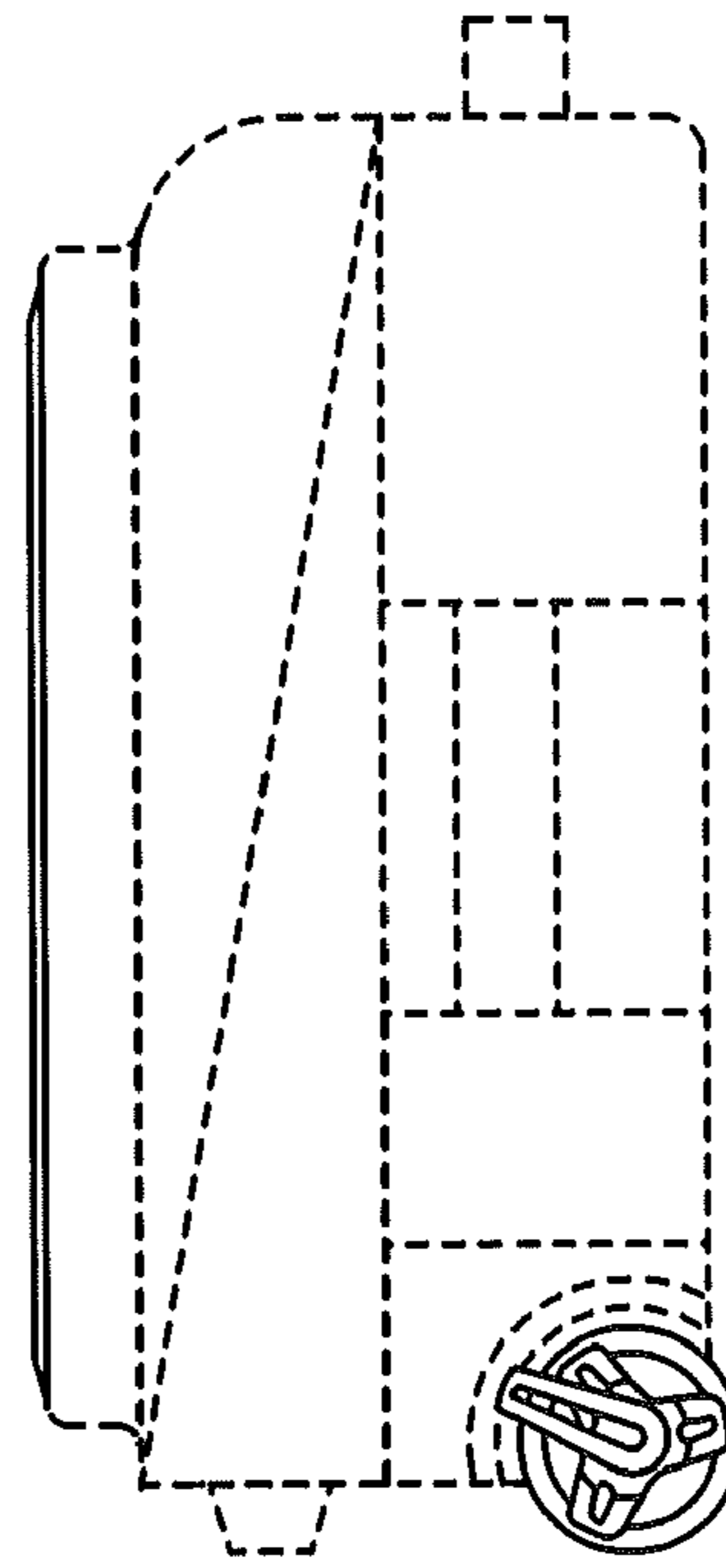

Fig. 4

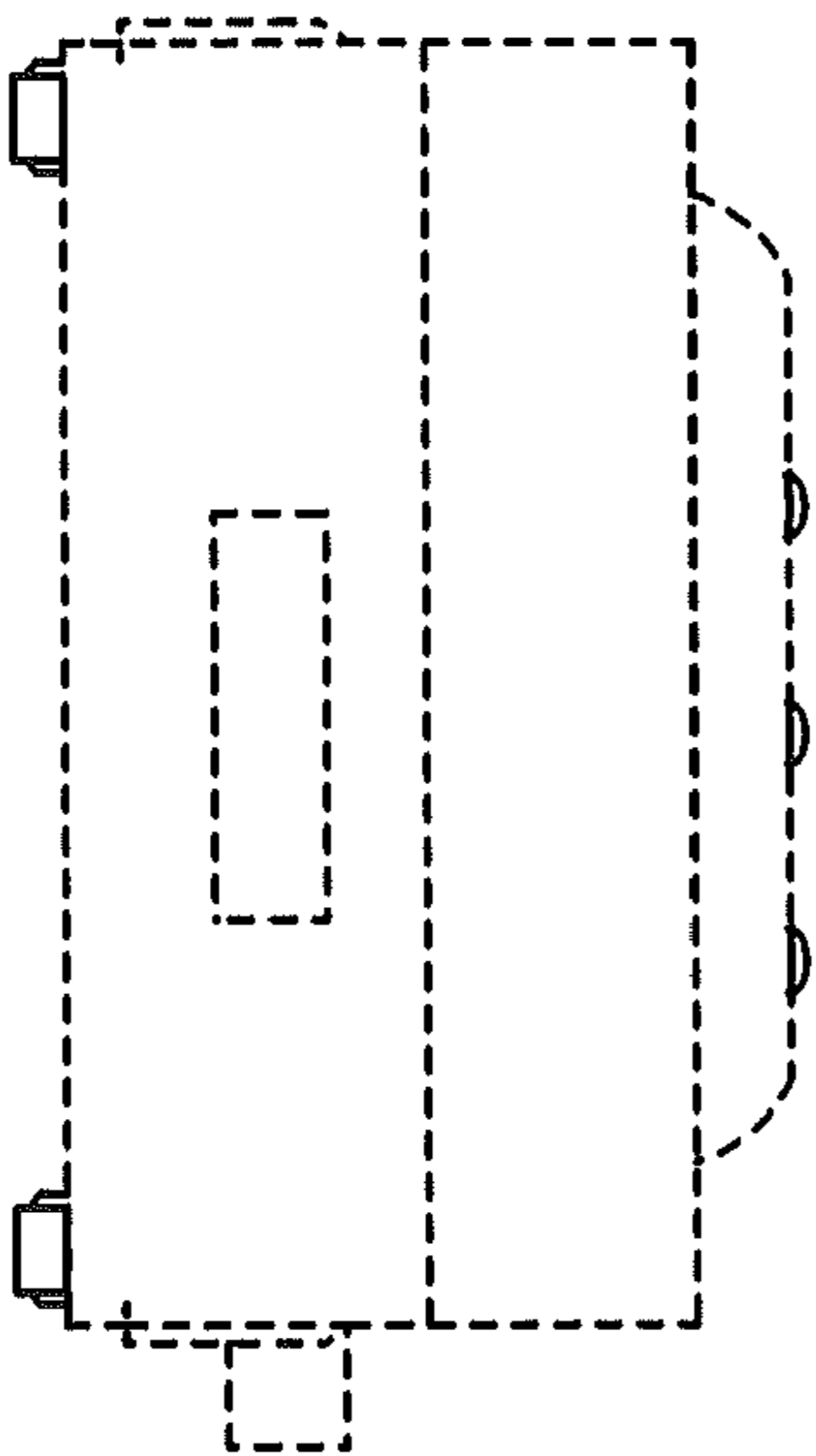

Fig. 5

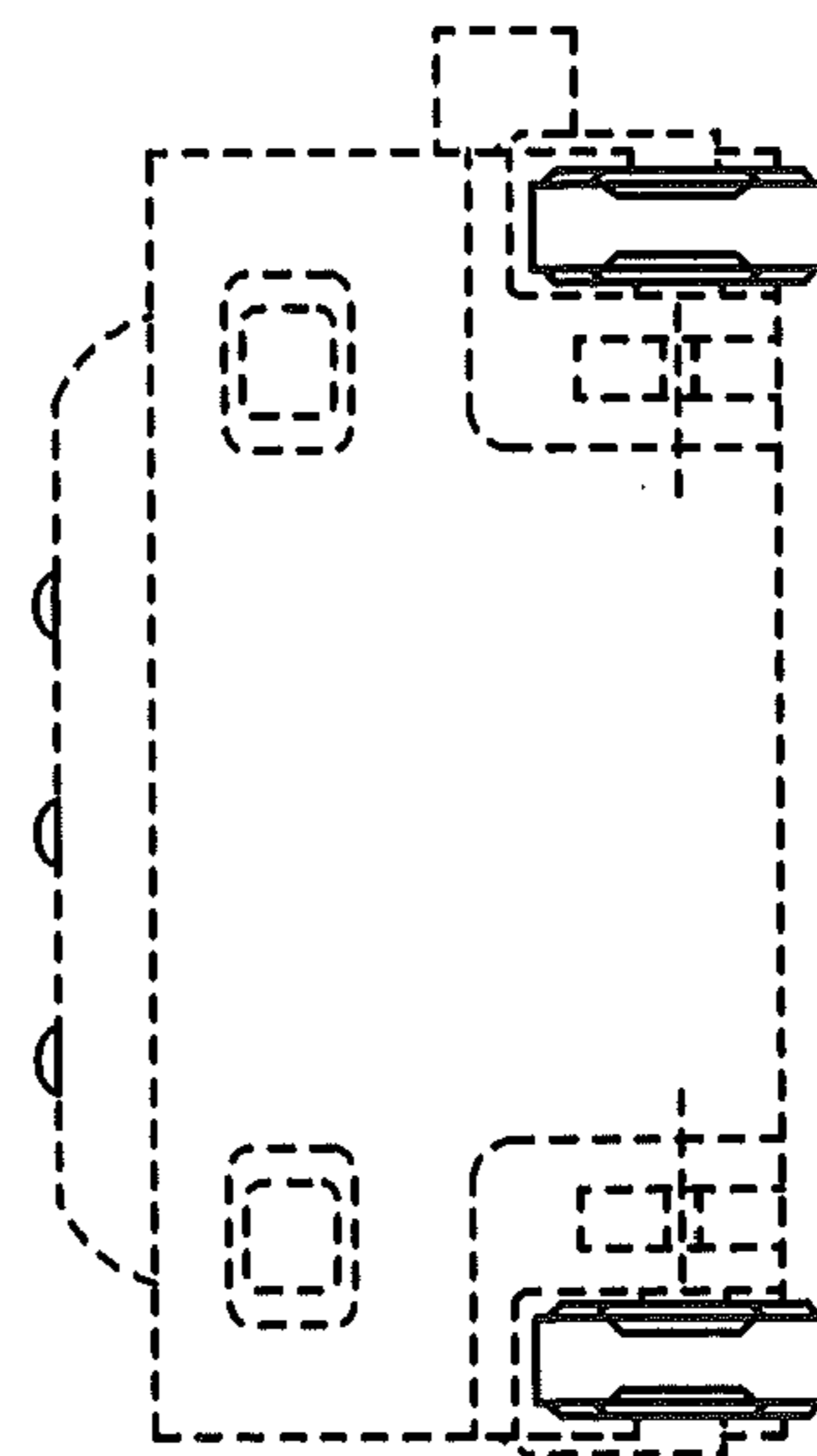

Fig. 6