



US00D651444S

(12) **United States Design Patent**
Lee

(10) **Patent No.:** **US D651,444 S**
(45) **Date of Patent:** **** Jan. 3, 2012**

(54) **WATER DISPENSER**

(75) Inventor: **Jeong Hun Lee**, Seoul (KR)

(73) Assignee: **Ceragem Co., Ltd.**,
Choongchungnamdo (KR)

(**) Term: **14 Years**

(21) Appl. No.: **29/381,577**

(22) Filed: **Dec. 21, 2010**

(30) **Foreign Application Priority Data**

Aug. 4, 2010 (KR) 30-2010-0034017

(51) **LOC (9) Cl.** **07-01**

(52) **U.S. Cl.** **D7/306; D7/311**

(58) **Field of Classification Search** D7/300,
D7/306-308, 309-311, 313, 305, 378, 397;
222/1, 129.1, 146.6, 185.1; 99/279

See application file for complete search history.

(56) **References Cited**

U.S. PATENT DOCUMENTS

3,220,334	A	*	11/1965	Martin	99/282
3,336,856	A	*	8/1967	Martin	99/288
D285,890	S	*	9/1986	Jack	D7/309
D295,939	S	*	5/1988	Dole et al.	D7/309
D299,900	S	*	2/1989	Marotta	D7/309
4,836,414	A	*	6/1989	Credle et al.	222/1
D311,846	S	*	11/1990	Kirschner et al.	D7/311
D316,796	S	*	5/1991	Kirschner et al.	D7/311
D319,364	S	*	8/1991	Steiner	D6/542

D324,319	S	*	3/1992	Faerber et al.	D7/308
D351,965	S	*	11/1994	Credle, Jr.	D7/311
D358,427	S	*	5/1995	Gobindram	D20/1
D361,689	S	*	8/1995	McCloskey	D7/309
D380,928	S	*	7/1997	Trybus	D7/309
D381,549	S	*	7/1997	James	D7/301
D509,701	S	*	9/2005	Lam	D7/309
D546,111	S	*	7/2007	Kim	D7/305
D581,717	S	*	12/2008	Parker et al.	D7/309
D600,061	S	*	9/2009	Glucksman et al.	D7/309
D607,683	S	*	1/2010	Choi	D7/309
D613,112	S	*	4/2010	Lippert et al.	D7/397
D622,533	S	*	8/2010	Gross et al.	D7/301
D622,536	S	*	8/2010	Ågren et al.	D7/309
D633,746	S	*	3/2011	Lam	D7/309

* cited by examiner

Primary Examiner — Marianne Pandozzi

(74) *Attorney, Agent, or Firm* — IPLA P.A.; James E. Bame

(57) **CLAIM**

The ornamental design for a water dispenser, as shown and described.

DESCRIPTION

FIG. 1 is a perspective view of a water dispenser showing my new design;

FIG. 2 is a front elevational view thereof;

FIG. 3 is a rear elevational view thereof;

FIG. 4 is a left side elevational view thereof;

FIG. 5 is a right side elevational view thereof;

FIG. 6 is a top plan view thereof; and,

FIG. 7 is a bottom plan view thereof.

1 Claim, 4 Drawing Sheets

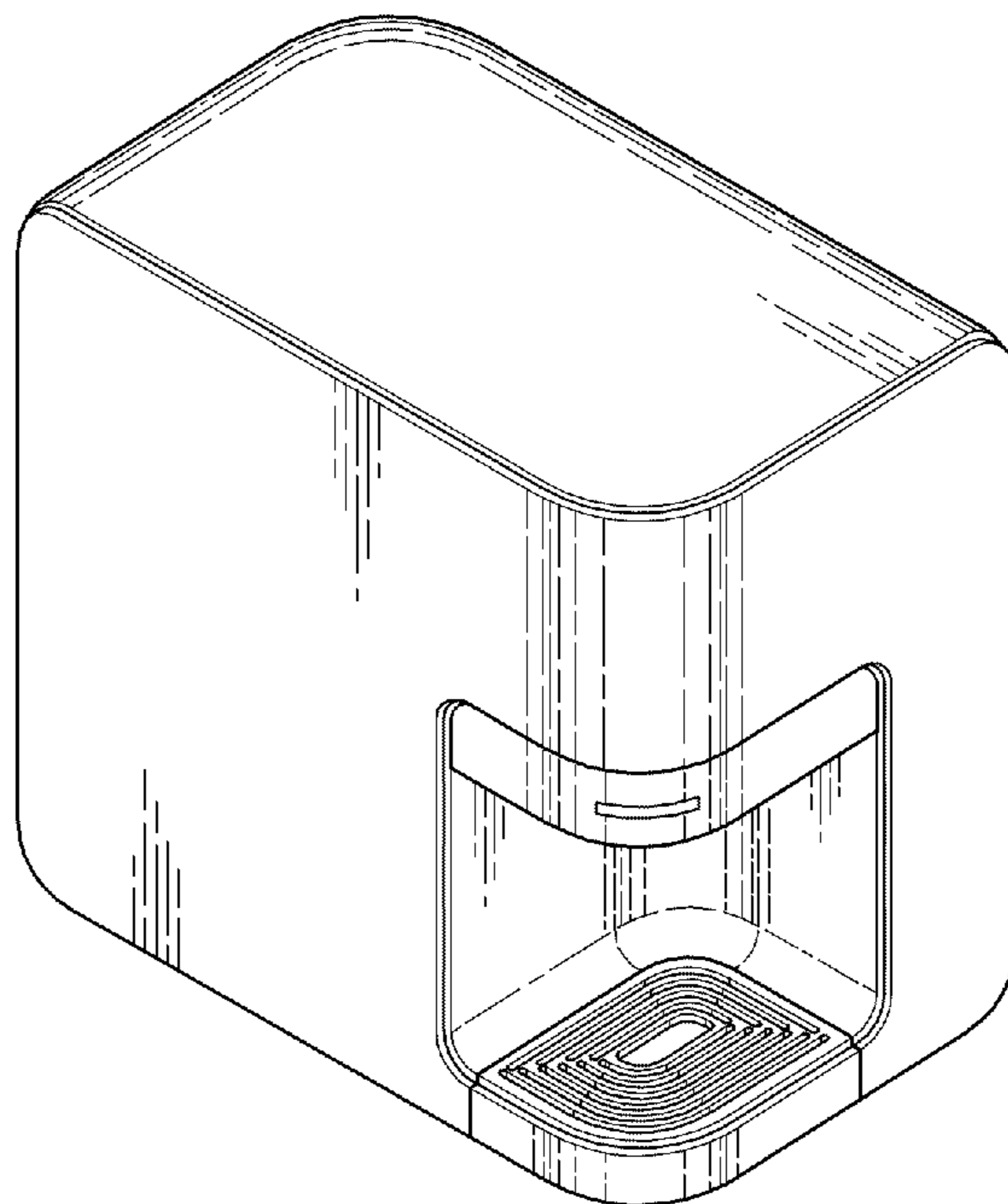

FIG. 1

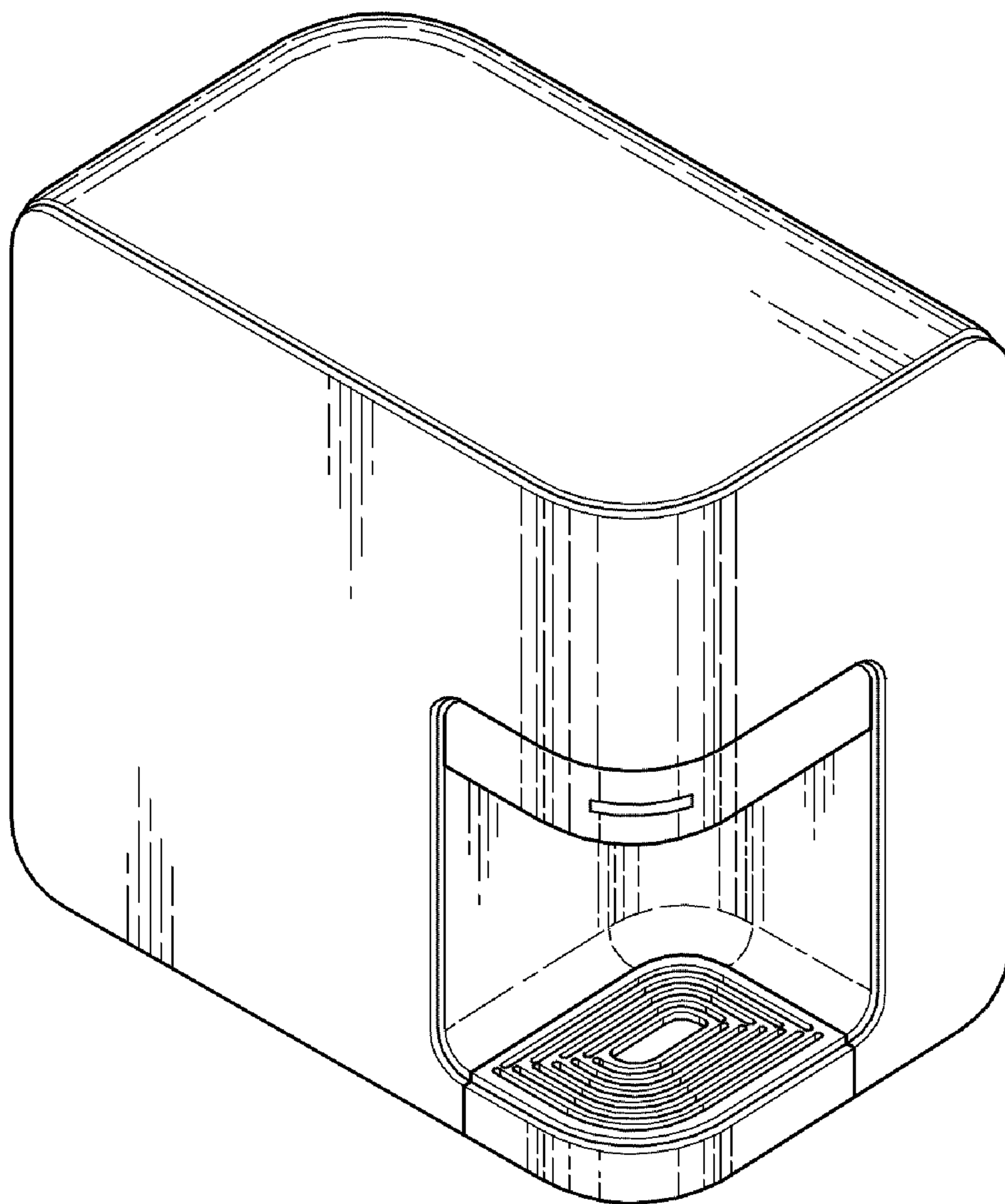

FIG. 2

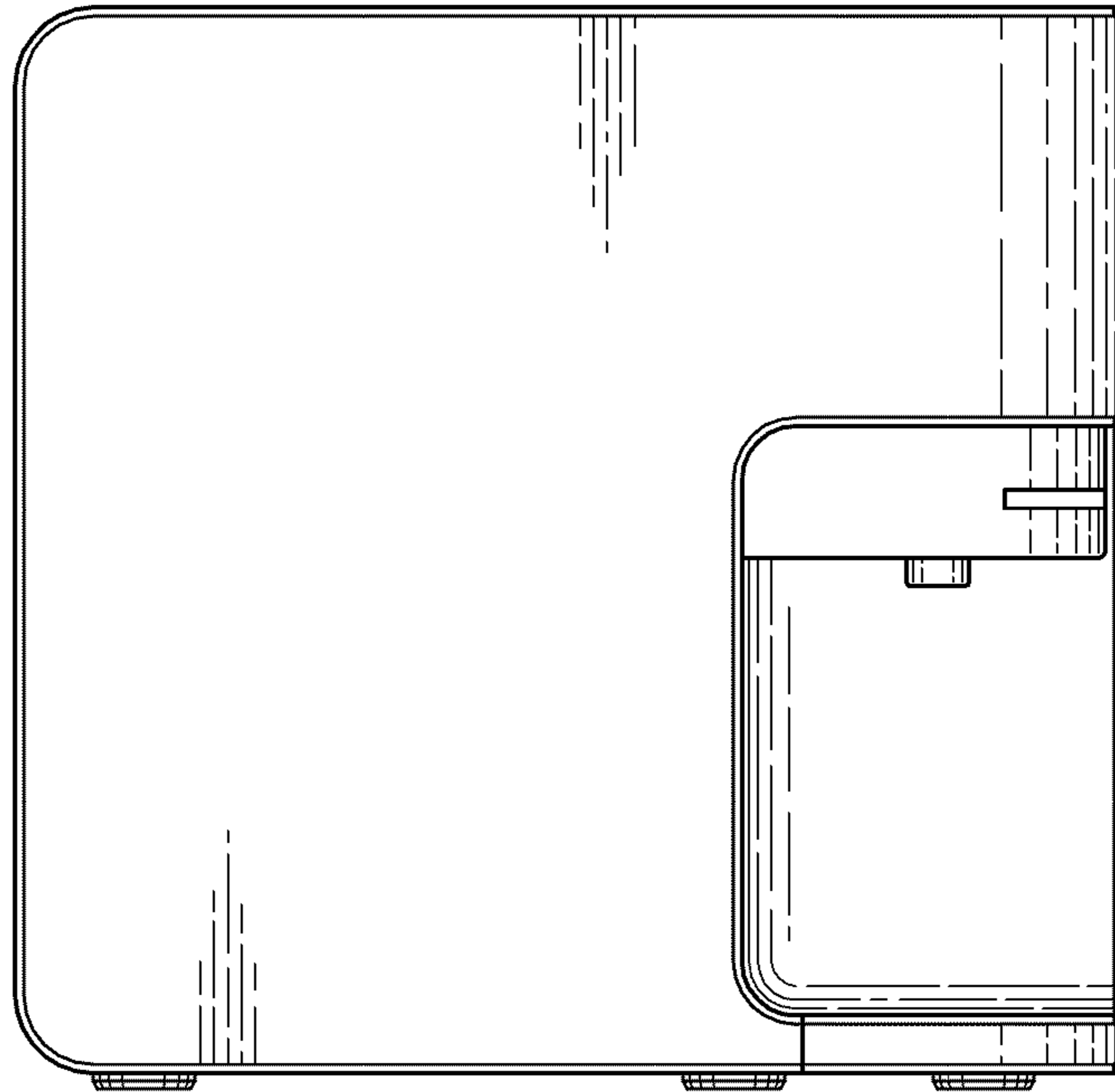

FIG. 3

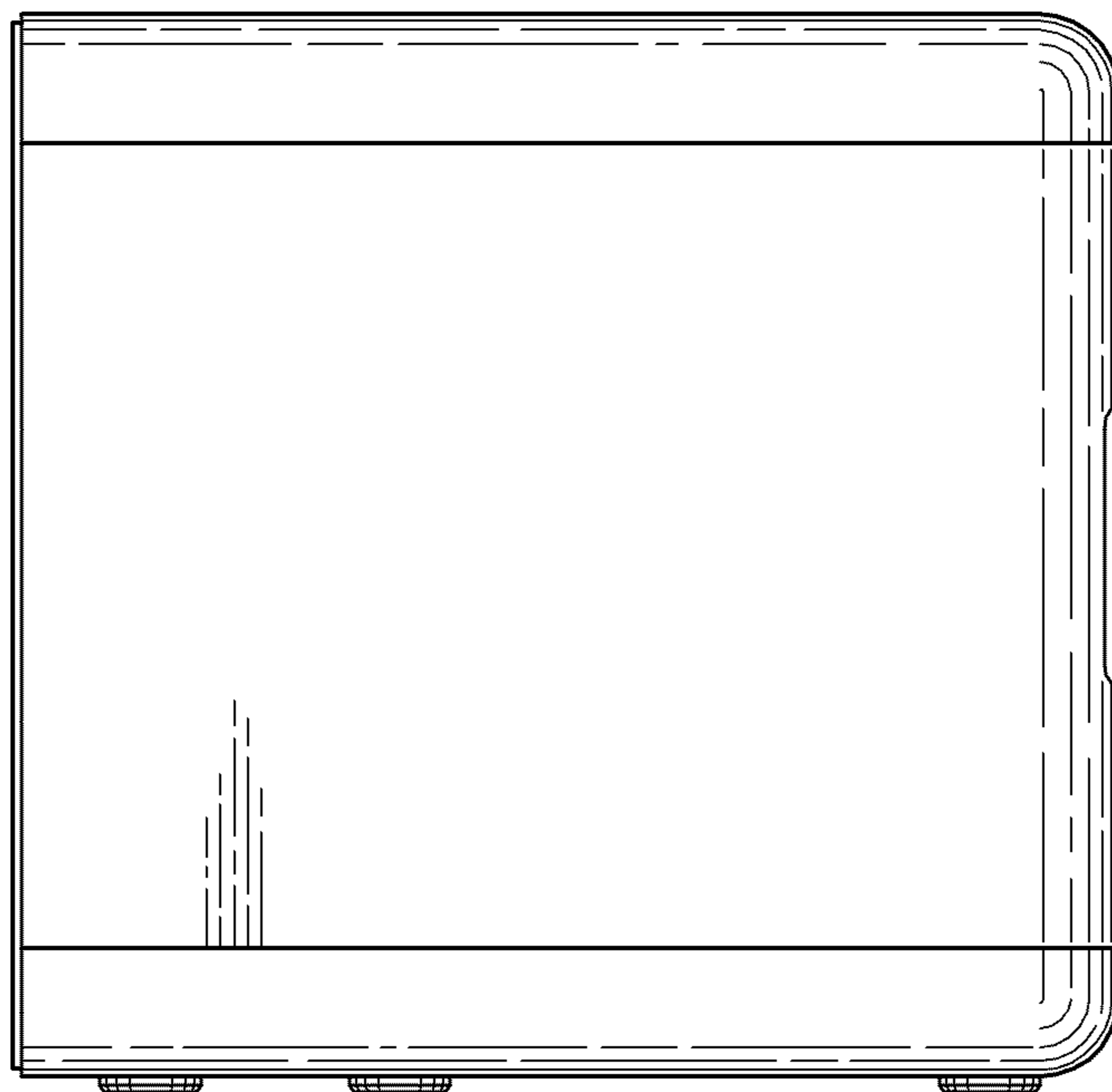

FIG. 4

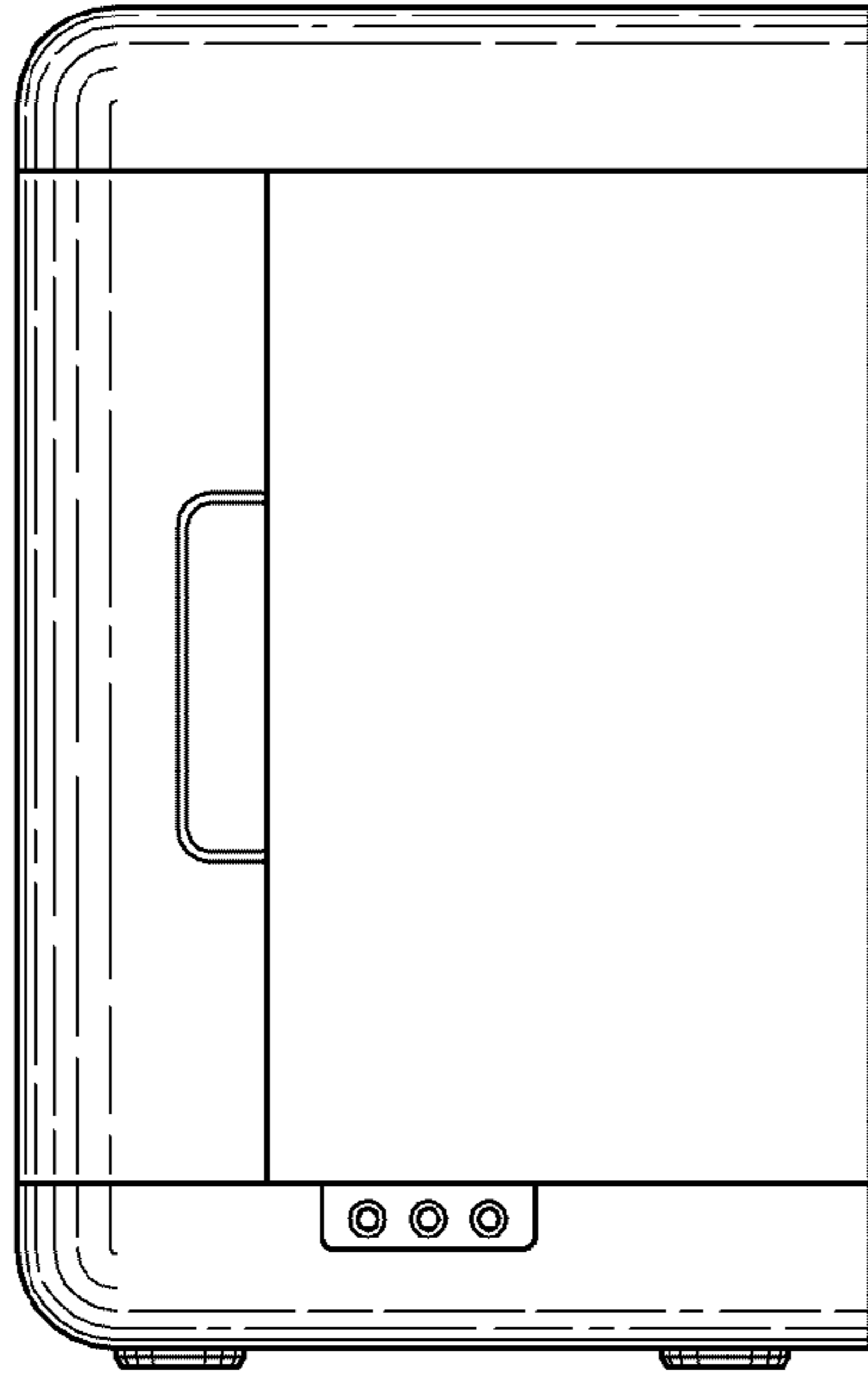

FIG. 5

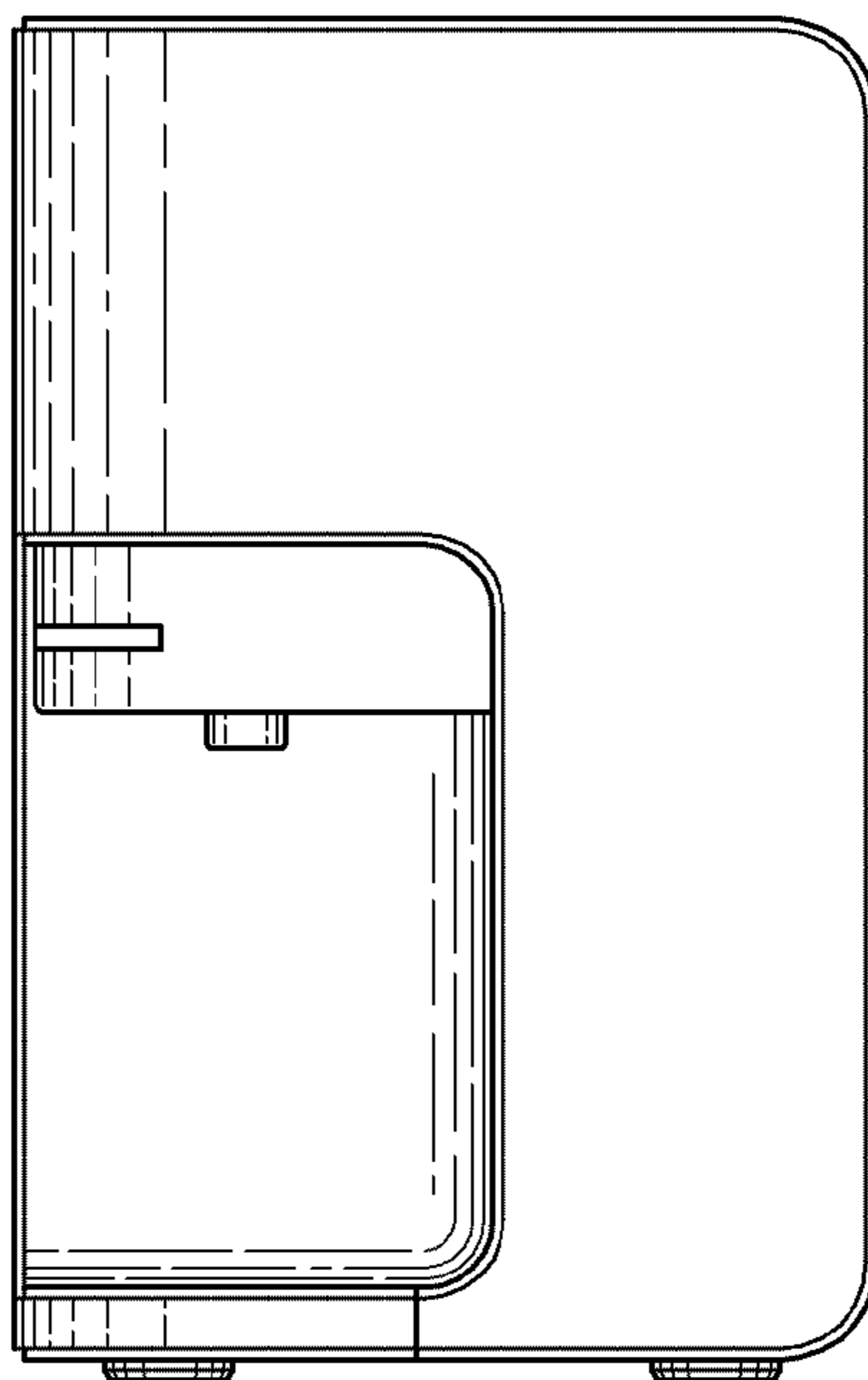

FIG. 6

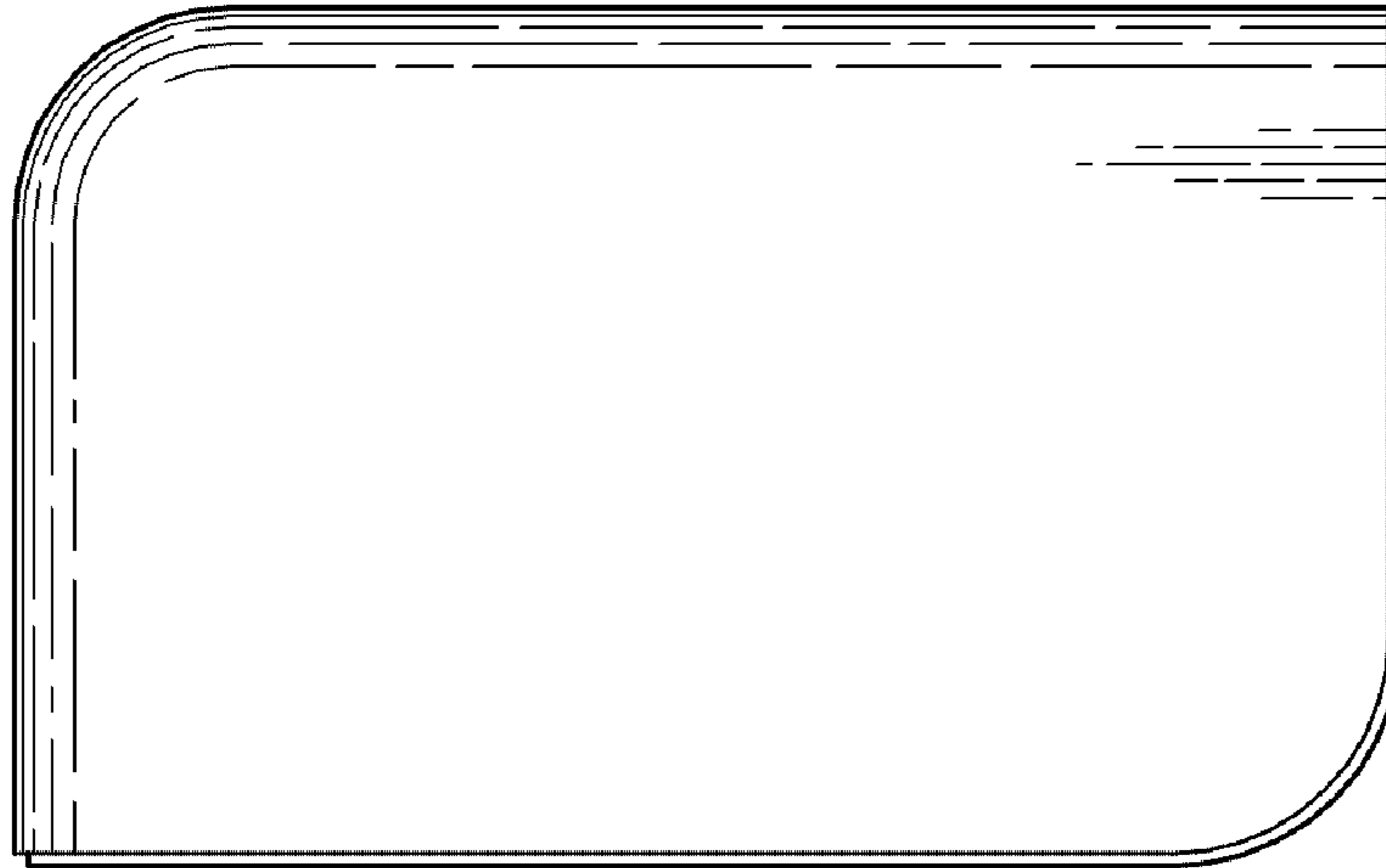

FIG. 7

