



US00D651419S

(12) **United States Design Patent**
Lievore

(10) **Patent No.:** **US D651,419 S**
(45) **Date of Patent:** **** Jan. 3, 2012**

(54) **ARMCHAIR**

(75) Inventor: **Alberto Lievore**, Monastier di Treviso (IT)

(73) Assignee: **Arper S.p.A.**, Monastier di Treviso, Treviso (IT)

(**) Term: **14 Years**

(21) Appl. No.: **29/353,456**

(22) Filed: **Jan. 8, 2010**

(30) **Foreign Application Priority Data**

Jul. 17, 2009 (WO) 504832801

(51) **LOC (9) Cl.** **06-01**

(52) **U.S. Cl.** **D6/334**

(58) **Field of Classification Search** D6/334,
D6/335, 337, 349, 353, 380, 381, 500-502,
D6/374; 297/14, 43, 44, 118, 140, 245, 300.1,
297/311, 353, 354.1, 445.1, 446.1, 446.2,
297/447.4, 465, 900, DIG. 2, DIG. 7; 5/12.1,
5/12.2

See application file for complete search history.

(56) **References Cited**

U.S. PATENT DOCUMENTS

D181,945 S * 1/1958 Saarinen D6/365
D278,581 S * 4/1985 Melchior D6/373

D303,326 S * 9/1989 Heimberger D6/334
D329,543 S * 9/1992 Shields D6/334
D380,095 S * 6/1997 Diaz-Azcuy D6/334
D382,123 S * 8/1997 Pimental et al. D6/334
D431,118 S * 9/2000 Hutton D6/334
D448,946 S * 10/2001 Goetz D6/381
D465,662 S * 11/2002 Hutton D6/334
D473,723 S * 4/2003 Pessa D6/334
D536,541 S * 2/2007 Kreiss D6/334
D550,465 S * 9/2007 Bouroullec et al. D6/334
D560,076 S * 1/2008 Moser D6/381
D633,725 S * 3/2011 Massaud D6/334

* cited by examiner

Primary Examiner — Sandra Snapp

(74) *Attorney, Agent, or Firm* — Shoemaker and Mattare

(57) **CLAIM**

The ornamental design for an armchair, as shown and described.

DESCRIPTION

FIG. 1 is a perspective view of an armchair, showing my new design from the front, top and right side;
FIG. 2 is a left side elevational view thereof;
FIG. 3 is a right side elevational view thereof;
FIG. 4 is a front elevational view thereof;
FIG. 5 is a rear elevational view thereof;
FIG. 6 is a top plan view thereof; and,
FIG. 7 is a bottom plan view thereof.

1 Claim, 7 Drawing Sheets

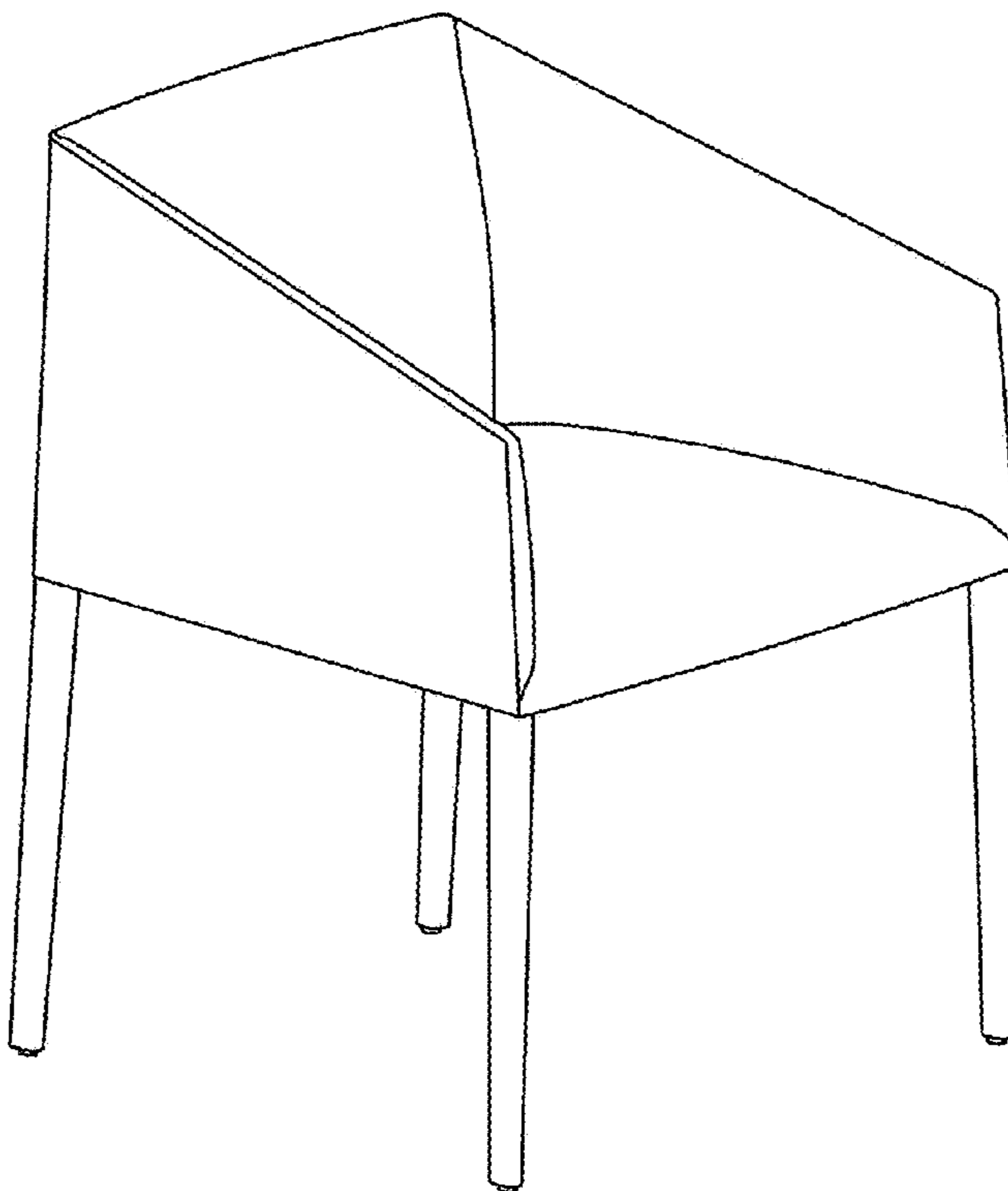

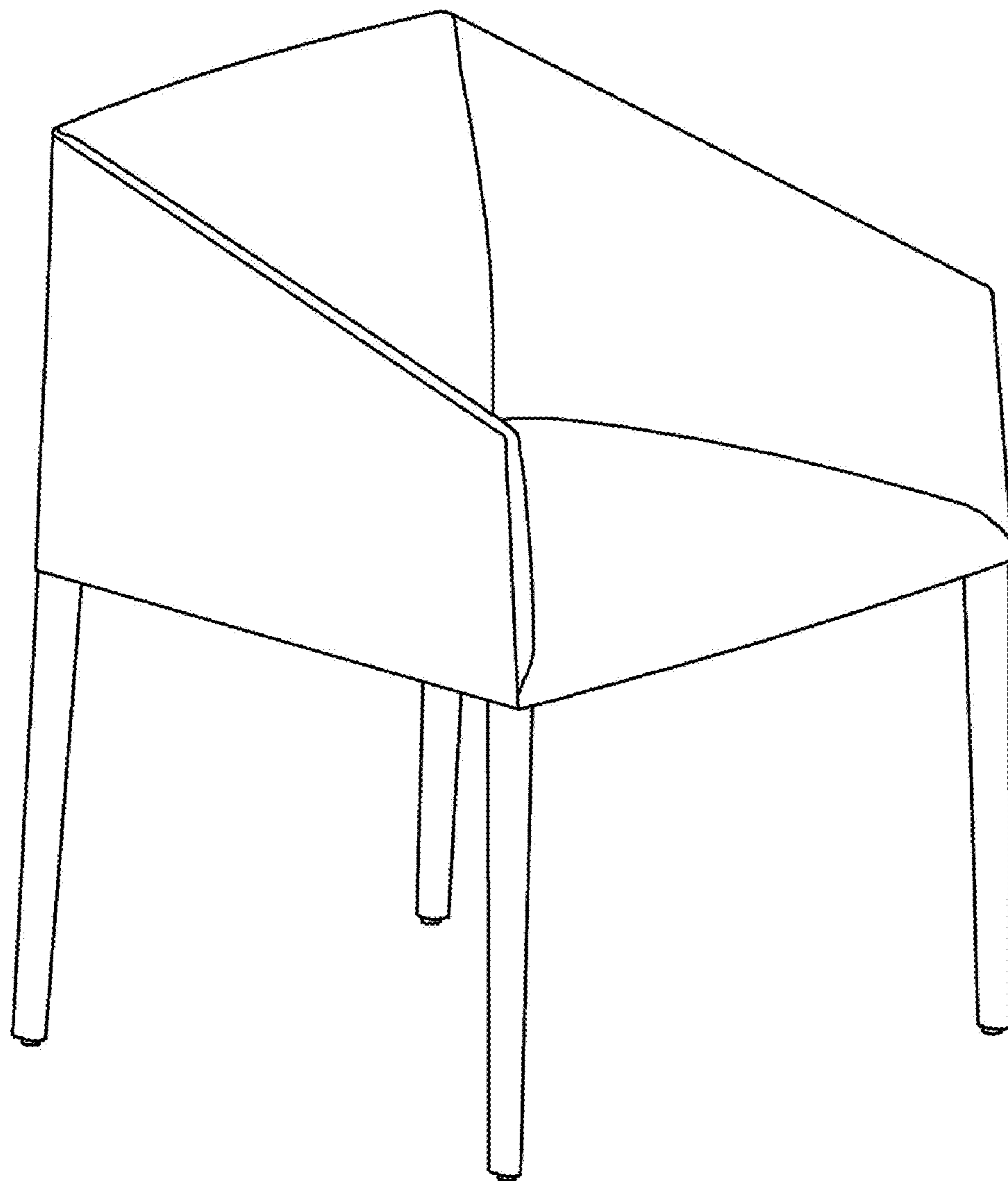

Fig. 1

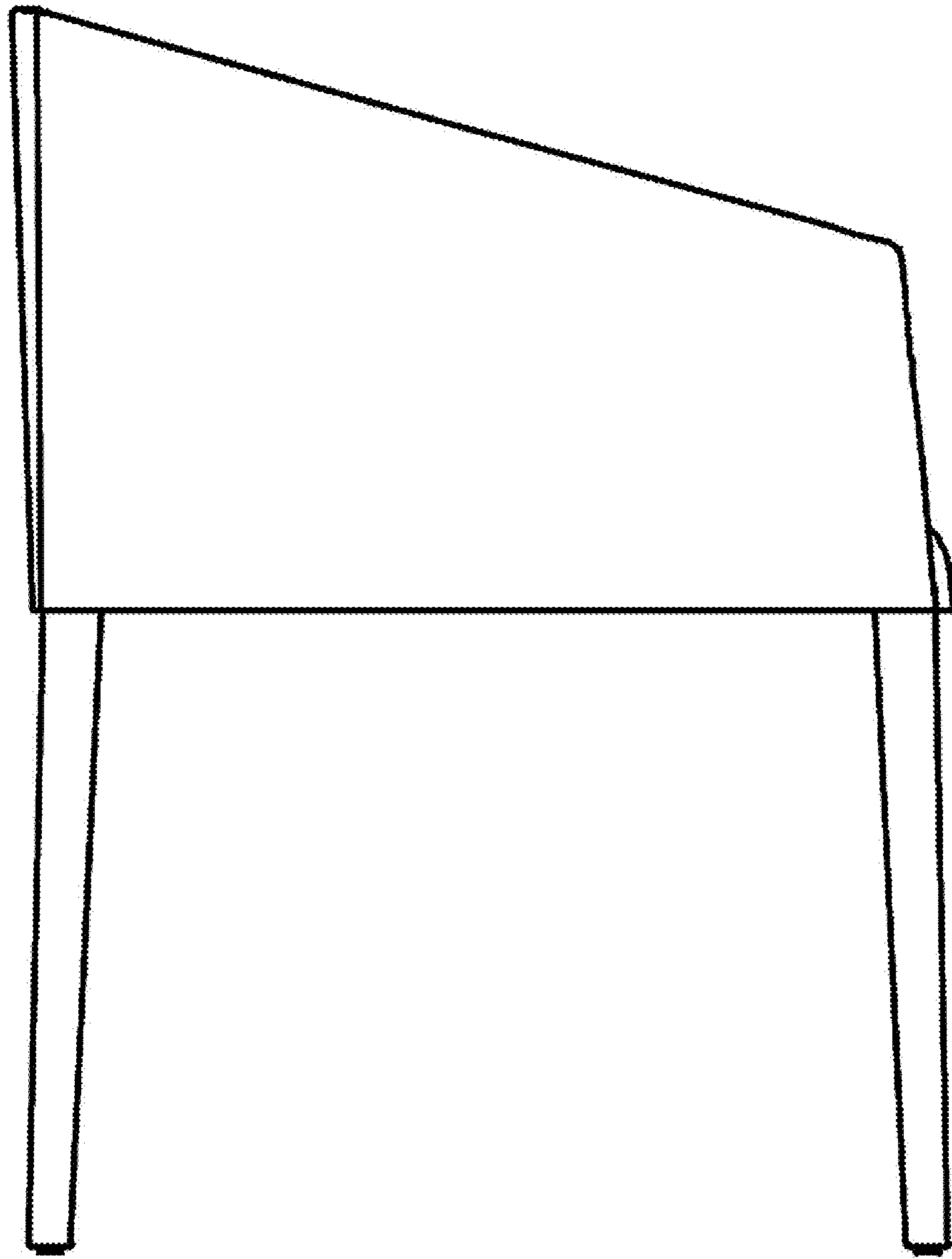

Fig. 2

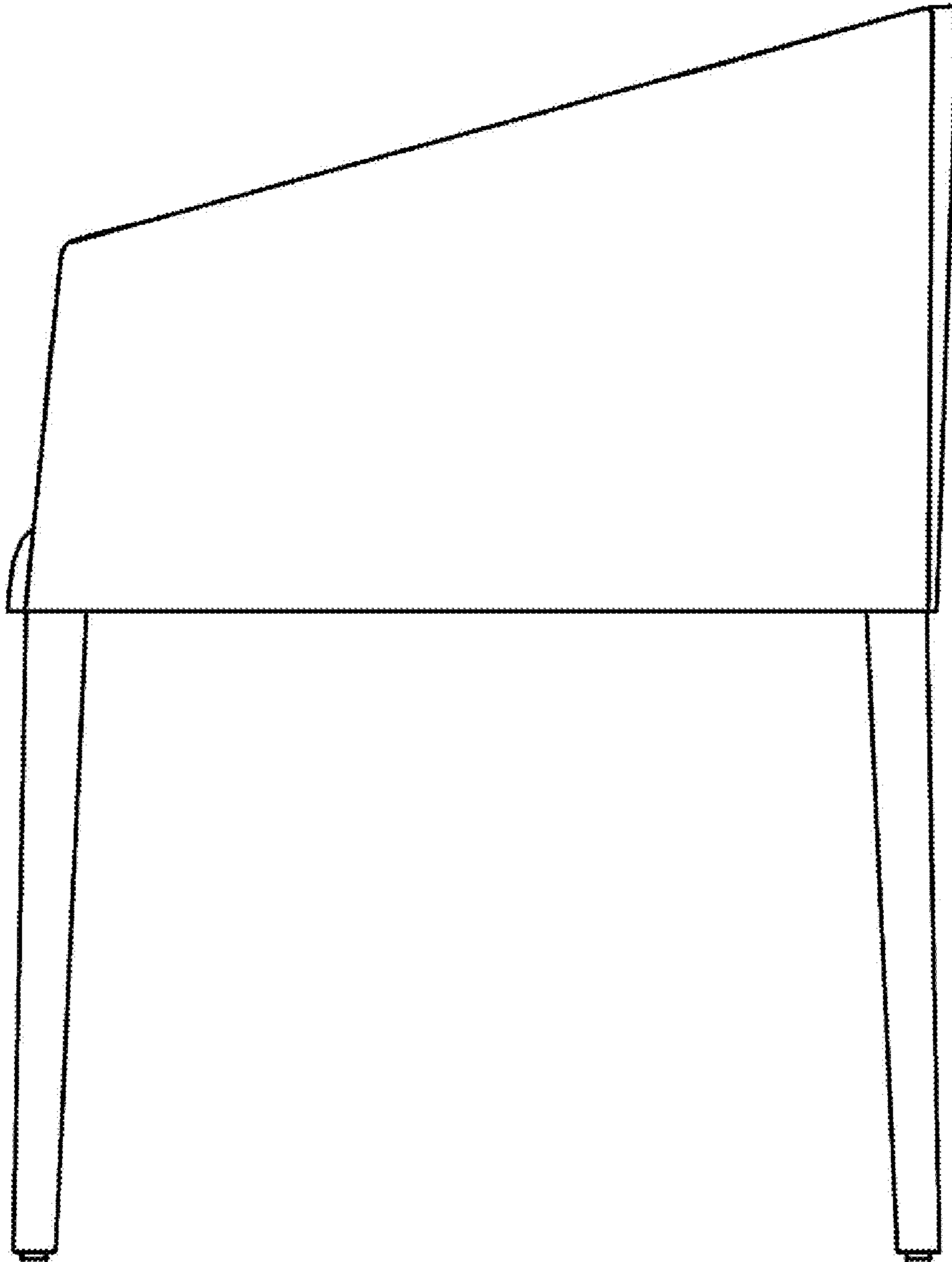

Fig. 3

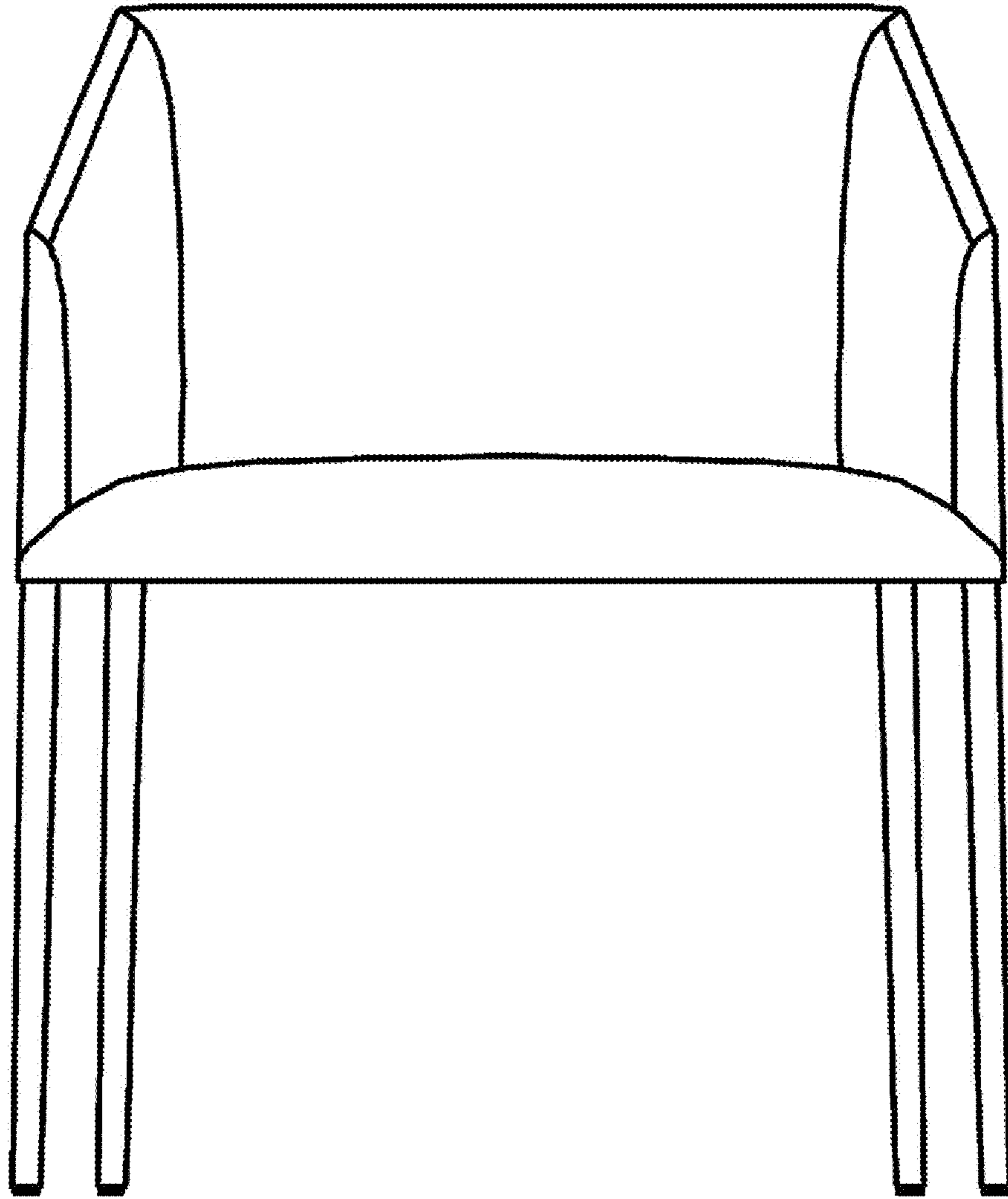

Fig. 4

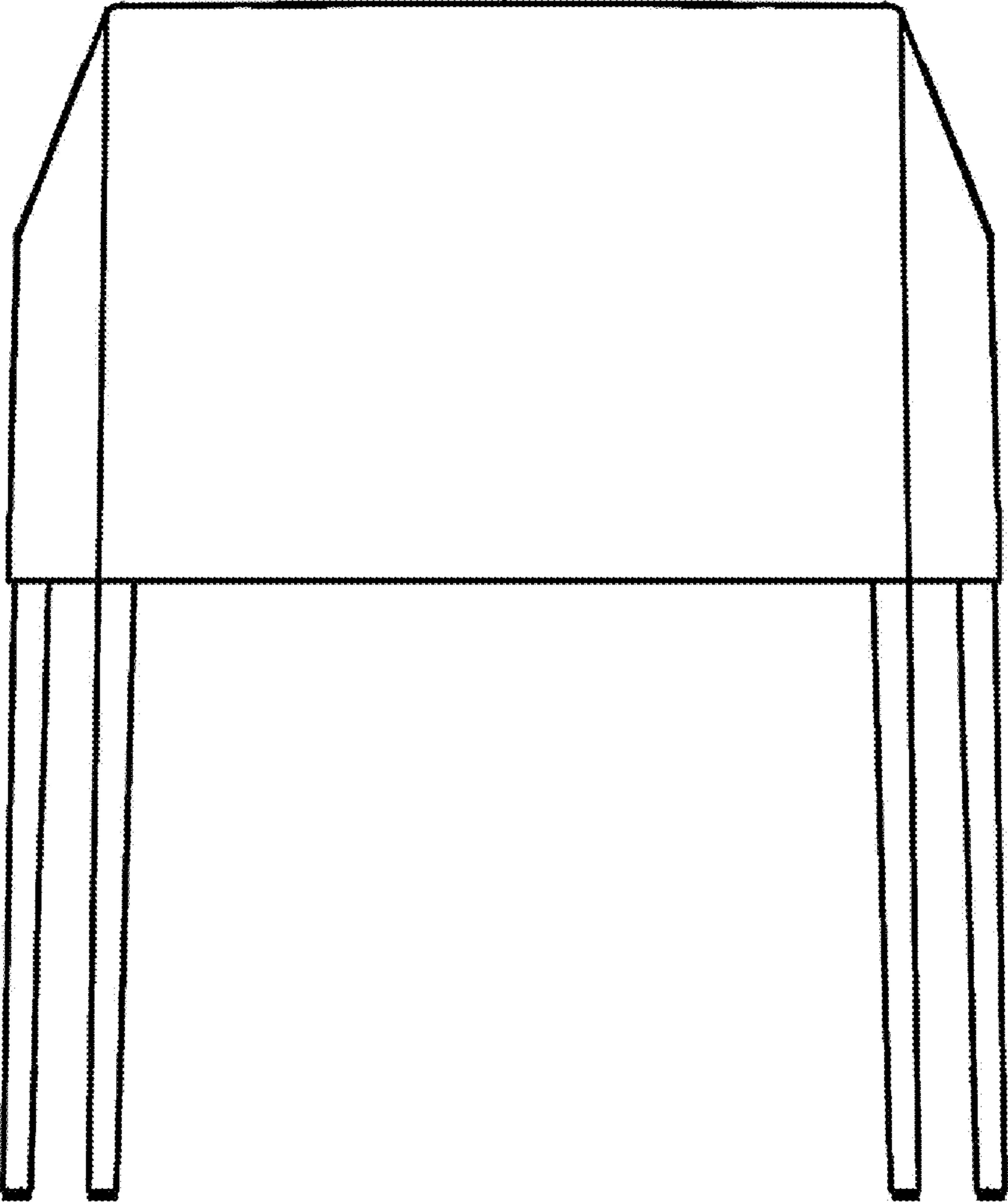

Fig. 5

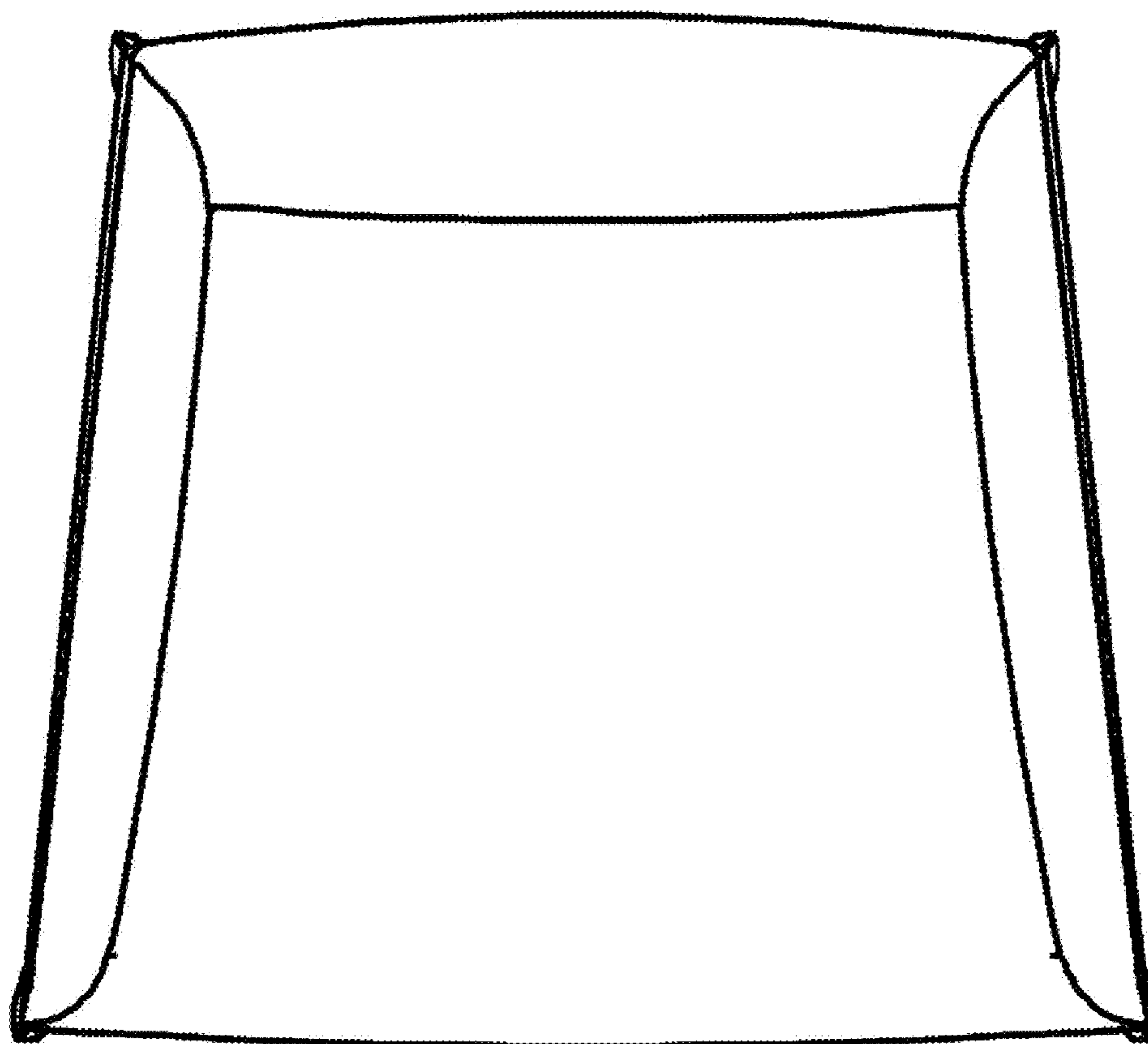

Fig. 6

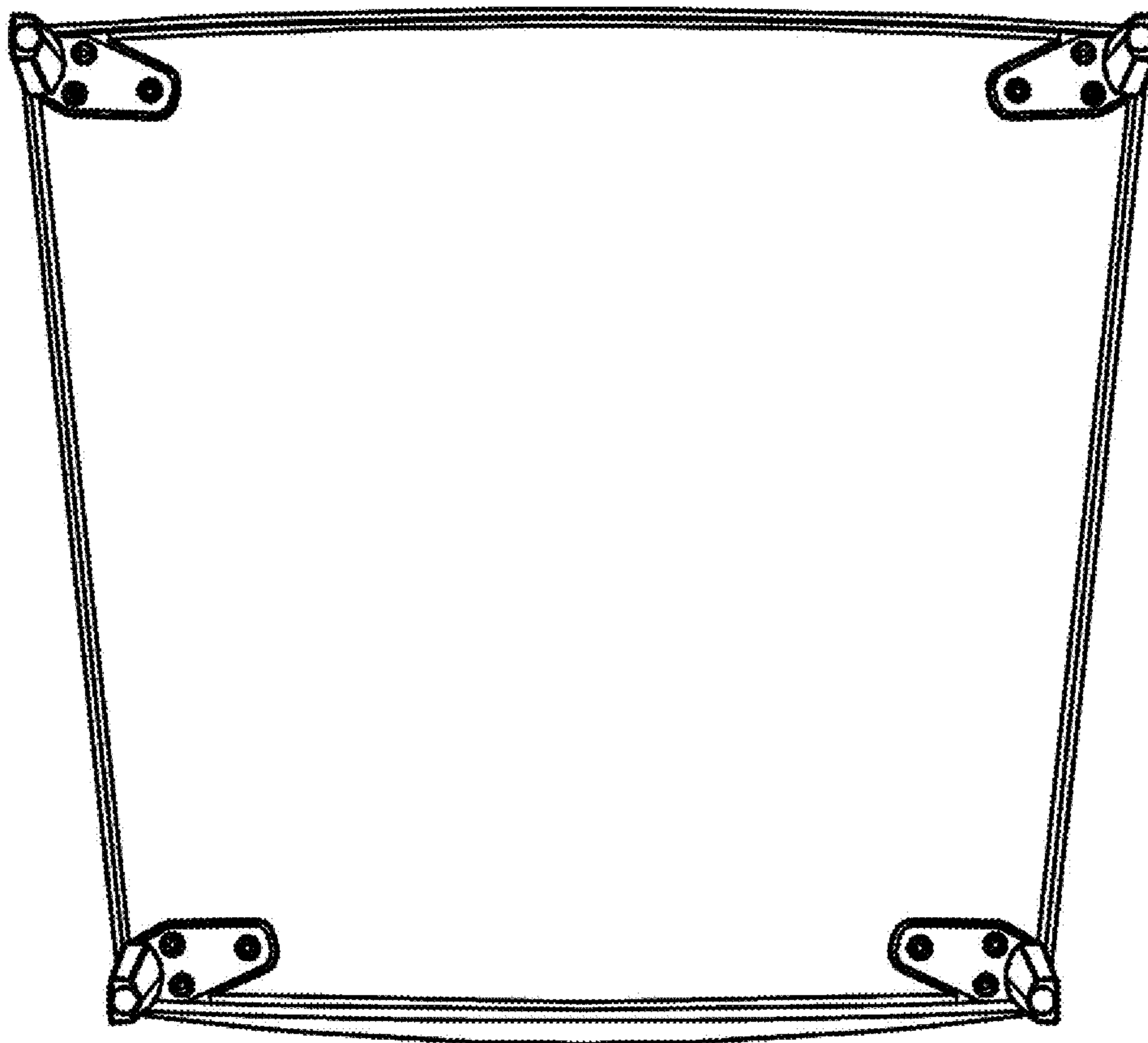

Fig. 7