



US00D651253S

(12) **United States Design Patent**
Hayes

(10) **Patent No.:** **US D651,253 S**

(45) **Date of Patent:** **** Dec. 27, 2011**

(54) **WINE BOTTLE LABEL**

(75) Inventor: **Stella Hayes**, Larchmont, NY (US)

(73) Assignee: **Everyday Cellars, Inc.**, Larchmont, NY (US)

(**) Term: **14 Years**

(21) Appl. No.: **29/360,014**

(22) Filed: **Apr. 19, 2010**

(51) **LOC (9) Cl.** **19-08**

(52) **U.S. Cl.** **D20/23; D20/25; D20/27**

(58) **Field of Classification Search** D20/10,
D20/11, 19, 22-28, 40, 99; 40/124.01-124.19,
40/124.11, 124.191, 299.01, 306, 310, 312,
40/313, 360, 446, 541, 584, 586, 625, 626,
40/630, 638, 661, 661.01; D19/1, 34; 24/17 A;
206/232; 283/51, 56, 61, 62, 71, 80, 81,
283/103, 106, 115; D14/489, 492, 495; D18/32,
D18/33

See application file for complete search history.

(56) **References Cited**

U.S. PATENT DOCUMENTS

492,641	A *	2/1893	Tibbals	40/310
1,583,527	A *	5/1926	Caldwell	283/115
3,695,422	A *	10/1972	Tripodi	206/232
4,312,523	A *	1/1982	Haines	40/630
5,343,648	A *	9/1994	Bracken	40/638
5,924,739	A *	7/1999	Garbutt	283/81
6,272,777	B1 *	8/2001	Swenson	40/310
D486,855	S *	2/2004	Bailey	D19/34
6,733,879	B2 *	5/2004	Ingerslew et al.	428/354
2002/0084647	A1 *	7/2002	Mitchell	283/51

2007/0004575	A1 *	1/2007	George	493/405
2007/0222205	A1 *	9/2007	Handa et al.	283/81
2008/0296886	A1 *	12/2008	Minor et al.	283/80

OTHER PUBLICATIONS

Sign language D Finger Pointing clip art—Clicker .com <http://www.clicker.com/clipart-9333.html> pulled from the web on Aug. 24, 2011.*
Sensory Perception Stock Vector—Shutterstock images <http://www.shutterstock.com/pic.mhtml?id=7137307> pulled from the web on Aug. 24, 2011.*

Thanksgiving Turkey Icon—WPClipart.com http://www.wpcipart.com/holiday/thanksgiving/more_turkeys/thanksgiving_turkey_icon.png.html pulled from the web on Aug. 24, 2011.*

* cited by examiner

Primary Examiner — Mary Ann Calabrese

(74) *Attorney, Agent, or Firm* — Blakely, Sokoloff, Taylor & Zafman, LLP

(57) **CLAIM**

The ornamental design for a wine bottle label, as shown and described.

DESCRIPTION

FIG. 1 is a front view of the wine bottle label design.

FIG. 2 is a rear view of the wine bottle label.

FIG. 3 is a left-side view of the wine bottle label.

FIG. 4 is a right-side view of the wine bottle label.

FIG. 5 is a top view of the wine bottle label; and,

FIG. 6 is a bottom view of the wine bottle label.

All of the text is in broken lines and forms no part of the claimed design. The bottle shown in broken lines illustrated environment and forms no part of the claimed design. View-points not illustrated present no additional ornamental features over those illustrated in the present set of drawings.

1 Claim, 3 Drawing Sheets

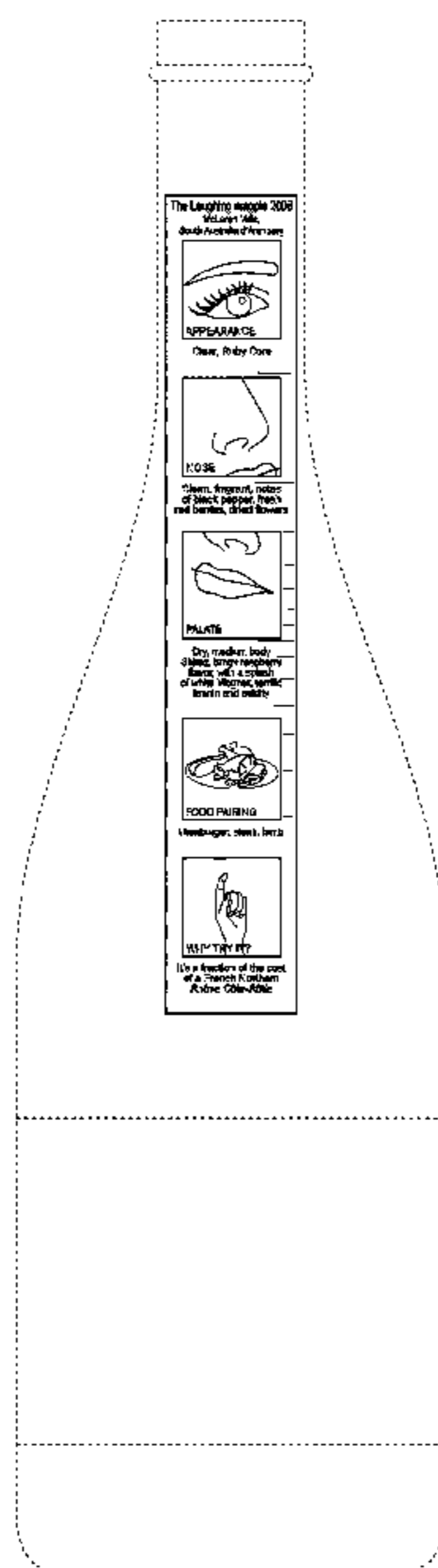

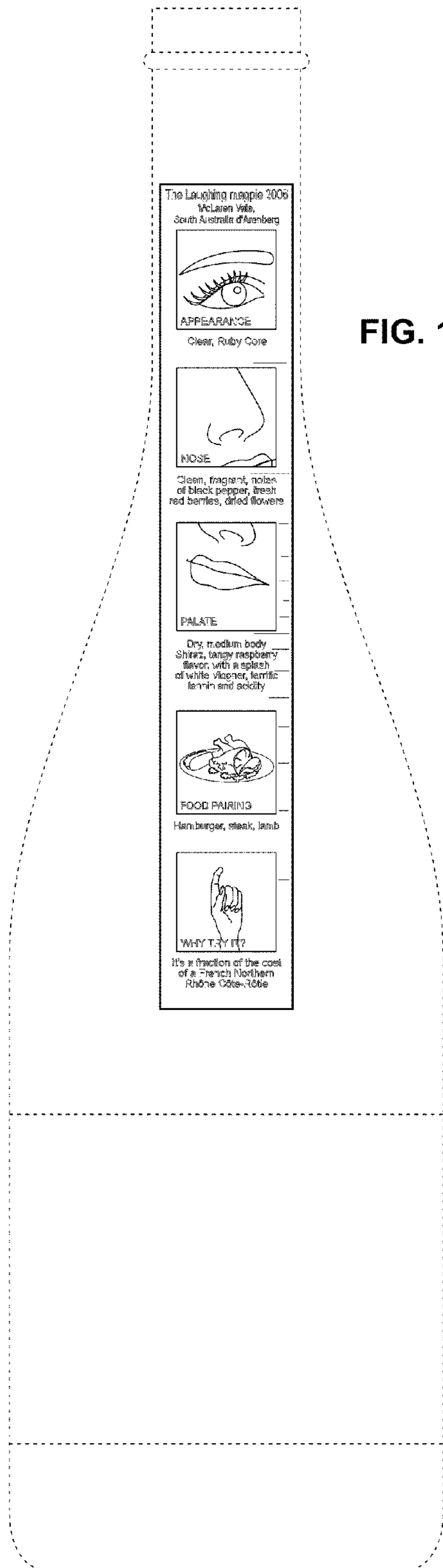

FIG. 1

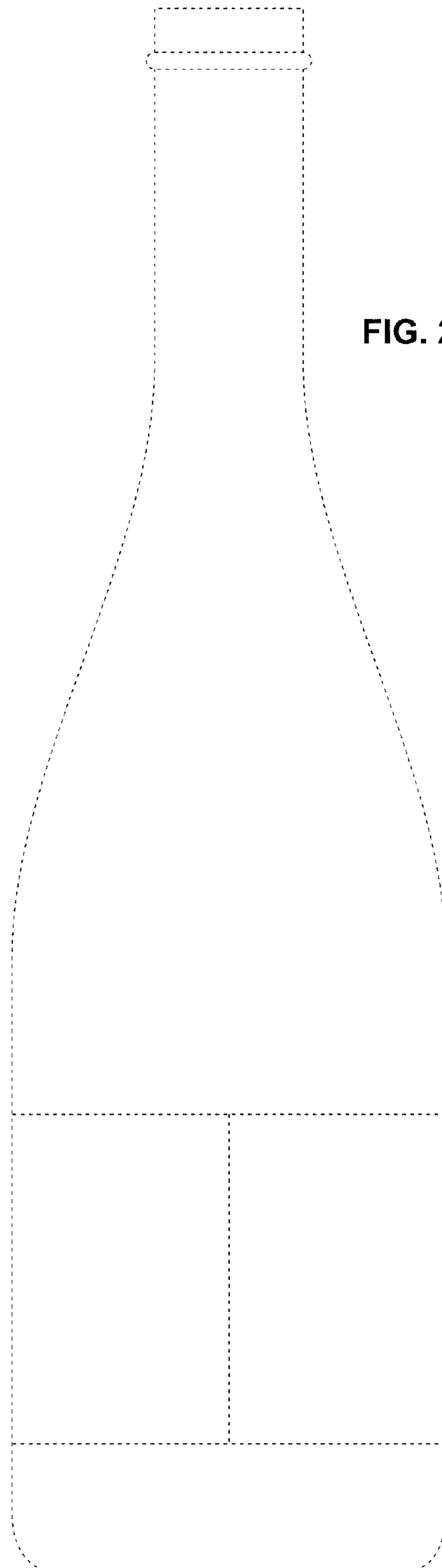

FIG. 2

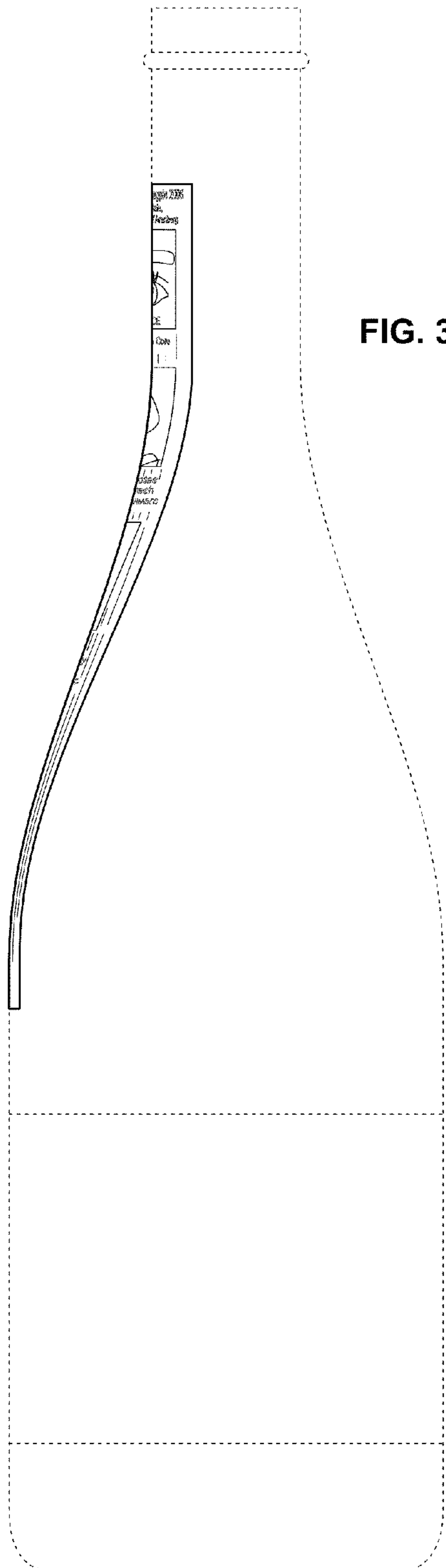

FIG. 3

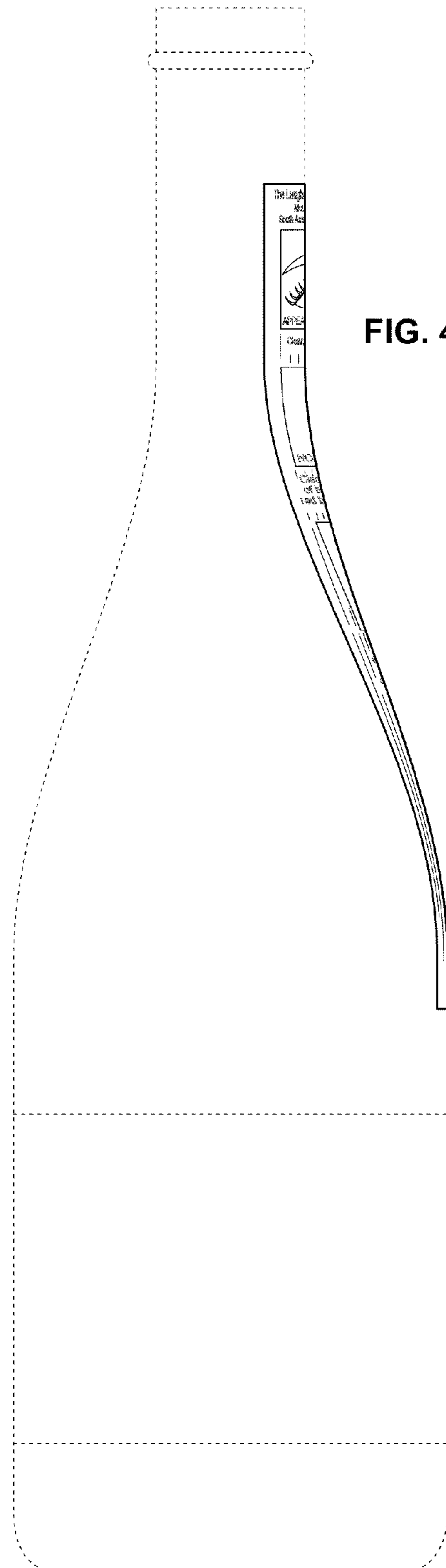

FIG. 4

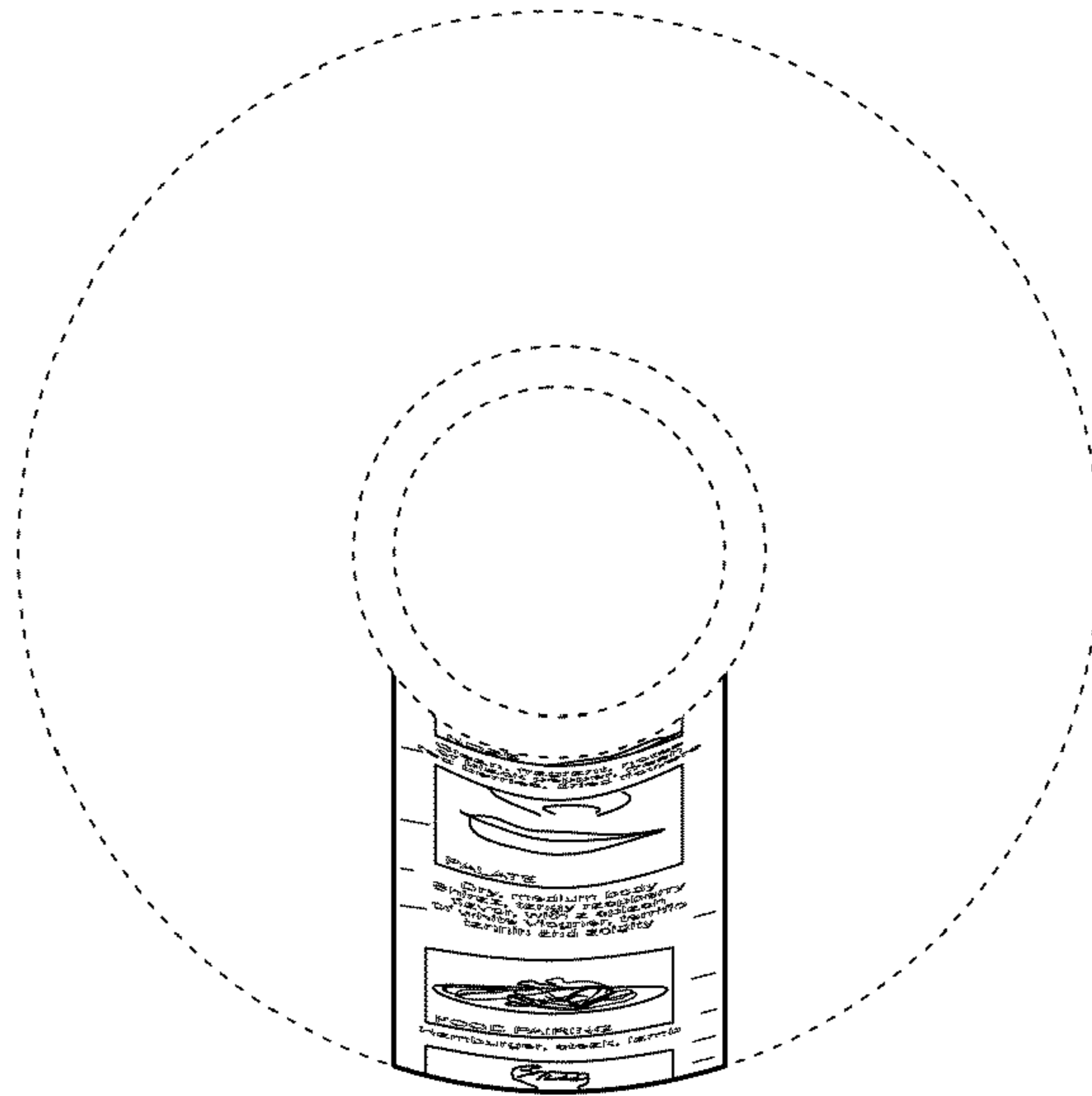

FIG. 5

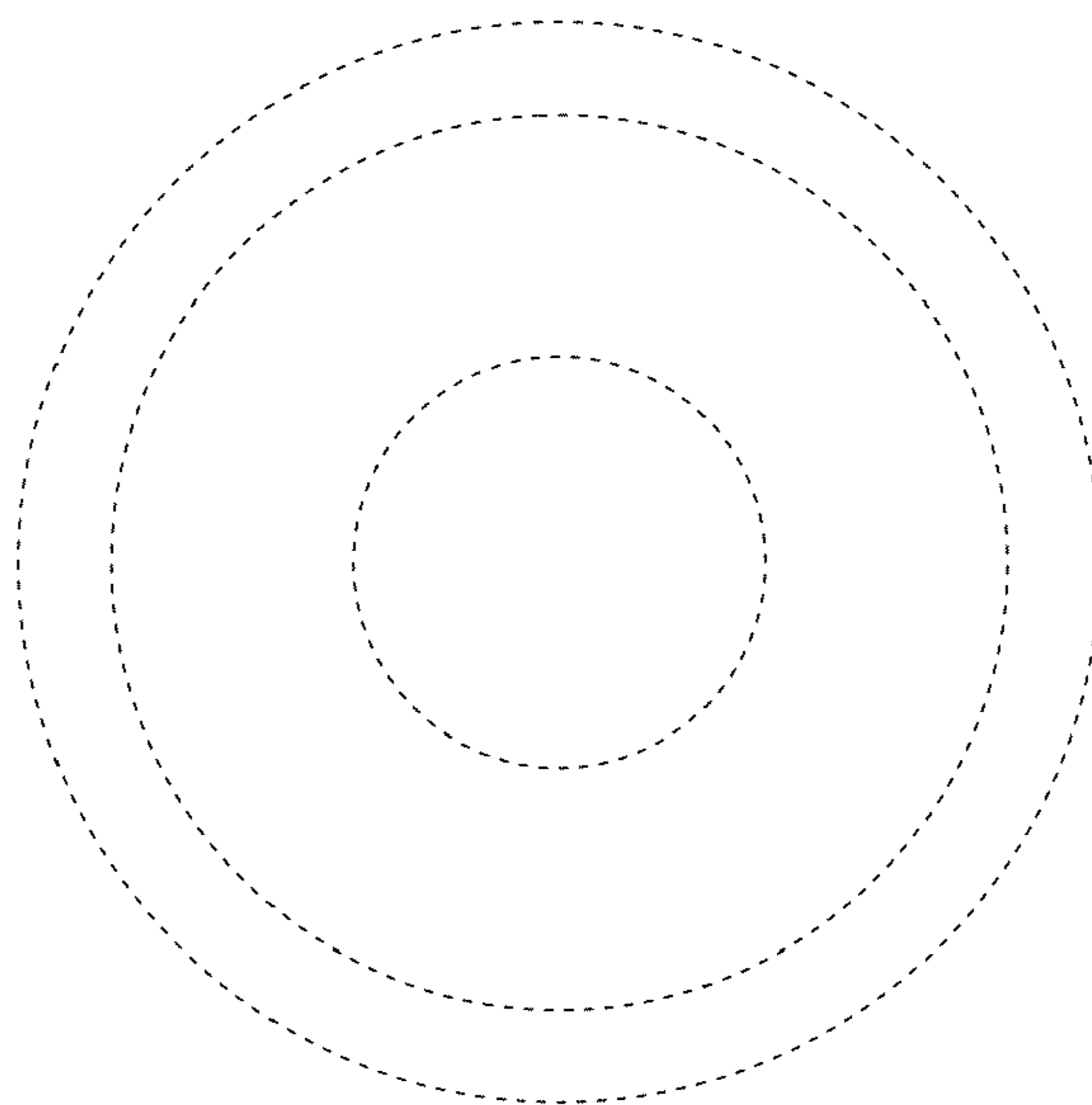

FIG. 6