



US00D651137S

(12) **United States Design Patent**
Lai et al.

(10) **Patent No.:** **US D651,137 S**

(45) **Date of Patent:** **** Dec. 27, 2011**

(54) **MOTORCYCLE**

(75) Inventors: **Guogui Lai**, Hangzhou (CN); **Youheng Qian**, Hangzhou (CN); **Zhangping Yuan**, Hangzhou (CN); **Hui Xu**, Hangzhou (CN); **Zhiyong Chen**, Hangzhou (CN); **Minqiang Xiong**, Hangzhou (CN)

(73) Assignee: **Zhejiang CFMOTO Power Co., Ltd.**, Hangzhou, Zhejiang Province (CN)

(**) Term: **14 Years**

(21) Appl. No.: **29/384,113**

(22) Filed: **Jan. 26, 2011**

(30) **Foreign Application Priority Data**

Dec. 13, 2010 (CN) 2010 3 0674737

(51) **LOC (9) Cl.** **12-11**

(52) **U.S. Cl.** **D12/110**

(58) **Field of Classification Search** D12/110;
180/219, 220, 225, 229

See application file for complete search history.

(56) **References Cited**

U.S. PATENT DOCUMENTS

D538,204 S * 3/2007 Tako et al. D12/110
D539,706 S * 4/2007 Huang D12/110
D590,749 S * 4/2009 Lai et al. D12/110

* cited by examiner

Primary Examiner — Susan M Lee

Assistant Examiner — Linda G. Brooks

(74) *Attorney, Agent, or Firm* — Wolf, Greenfield & Sacks, P.C.

(57) **CLAIM**

The ornamental design for a motorcycle, as shown and described.

DESCRIPTION

FIG. 1 is a front view of the motorcycle;
FIG. 2 is a back view of the motorcycle;
FIG. 3 is a left view of the motorcycle;
FIG. 4 is a right view of the motorcycle;
FIG. 5 is a top view of the motorcycle; and,
FIG. 6 is a perspective view of the motorcycle.

There is no design feature to be shown in the bottom view of the motorcycle, and thus the bottom view of the motorcycle is omitted therein.

The broken lines illustrate portions of the motorcycle that form no part of the claimed design.

1 Claim, 6 Drawing Sheets

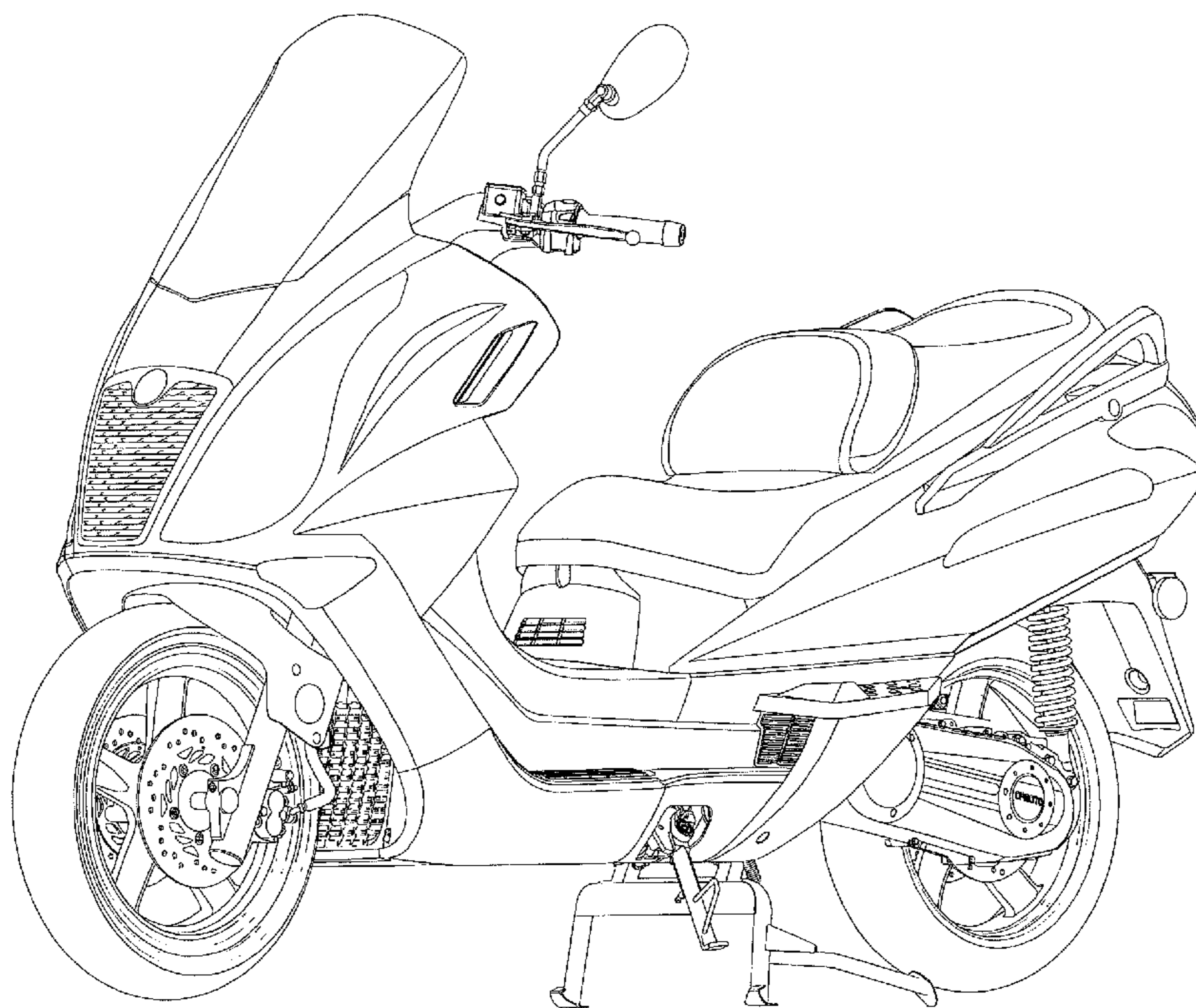

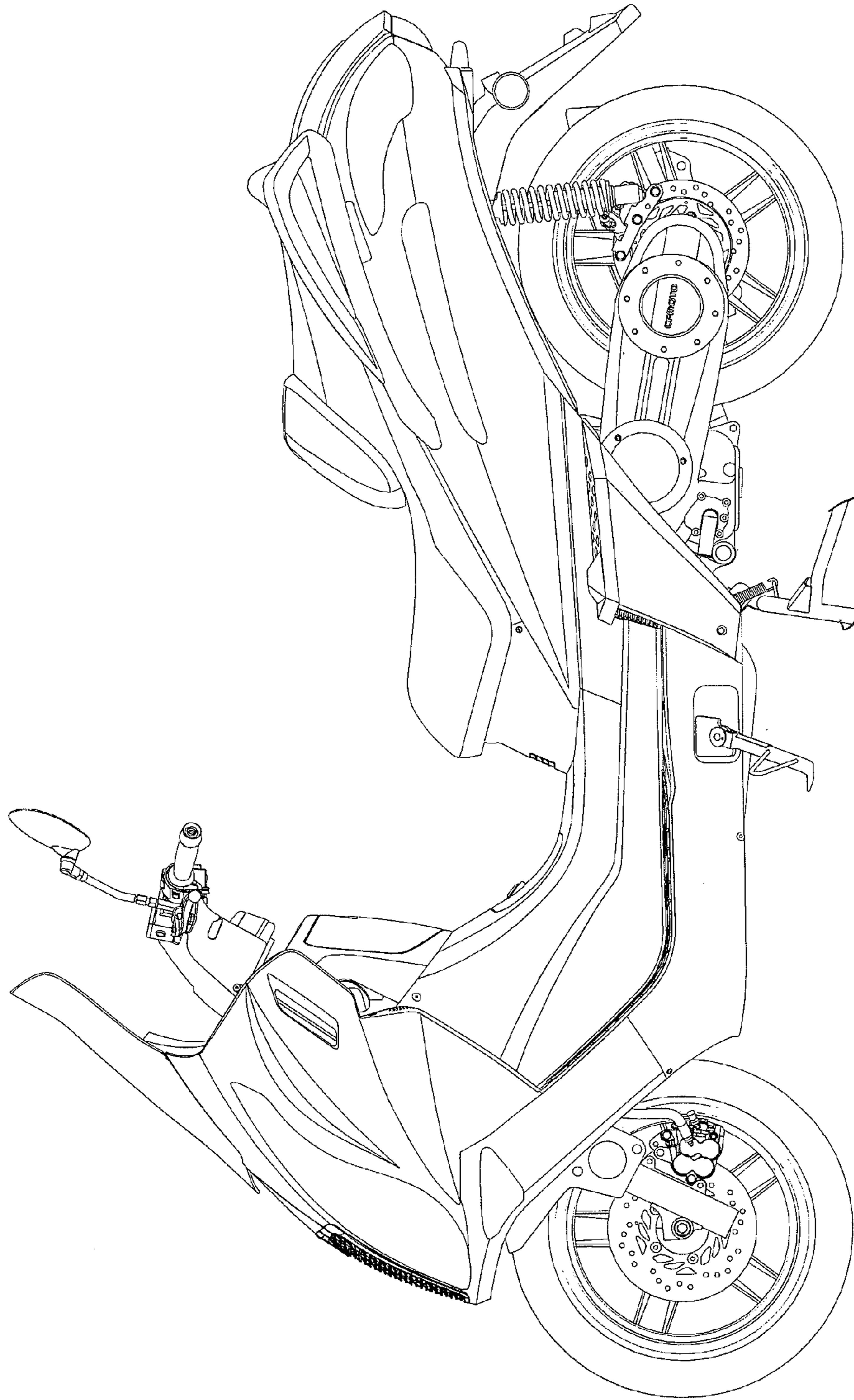

Fig. 1

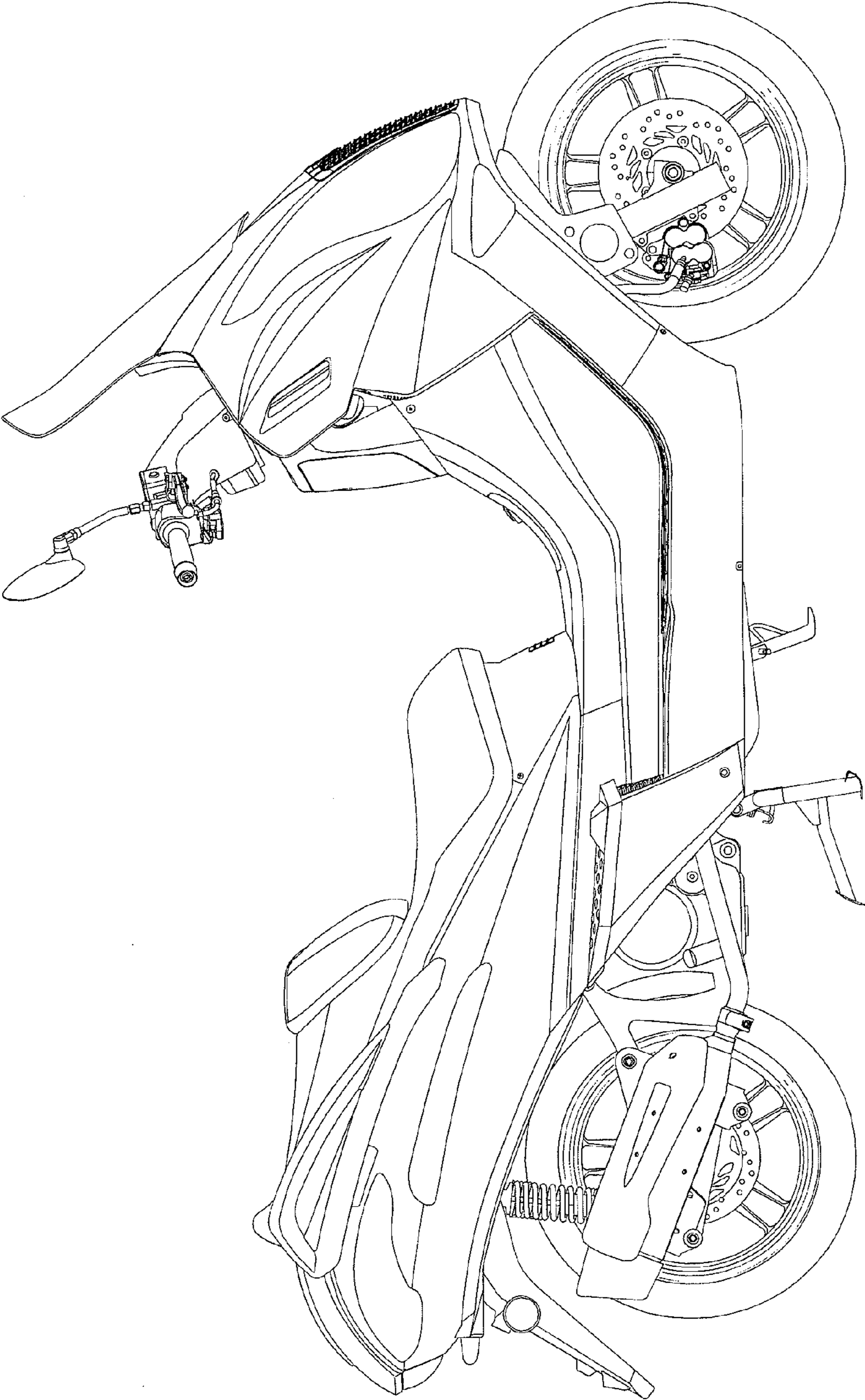

Fig. 2

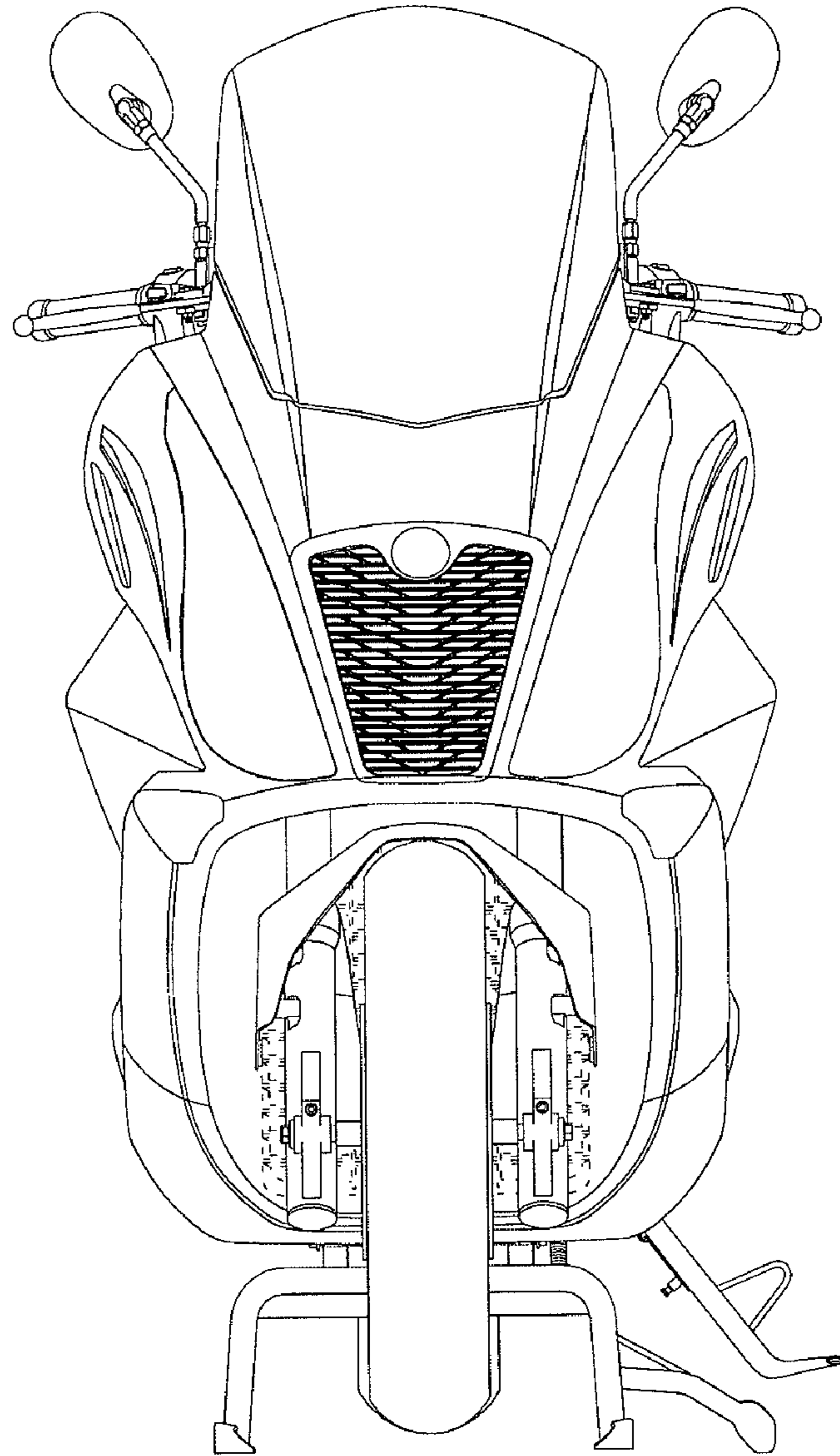

Fig. 3

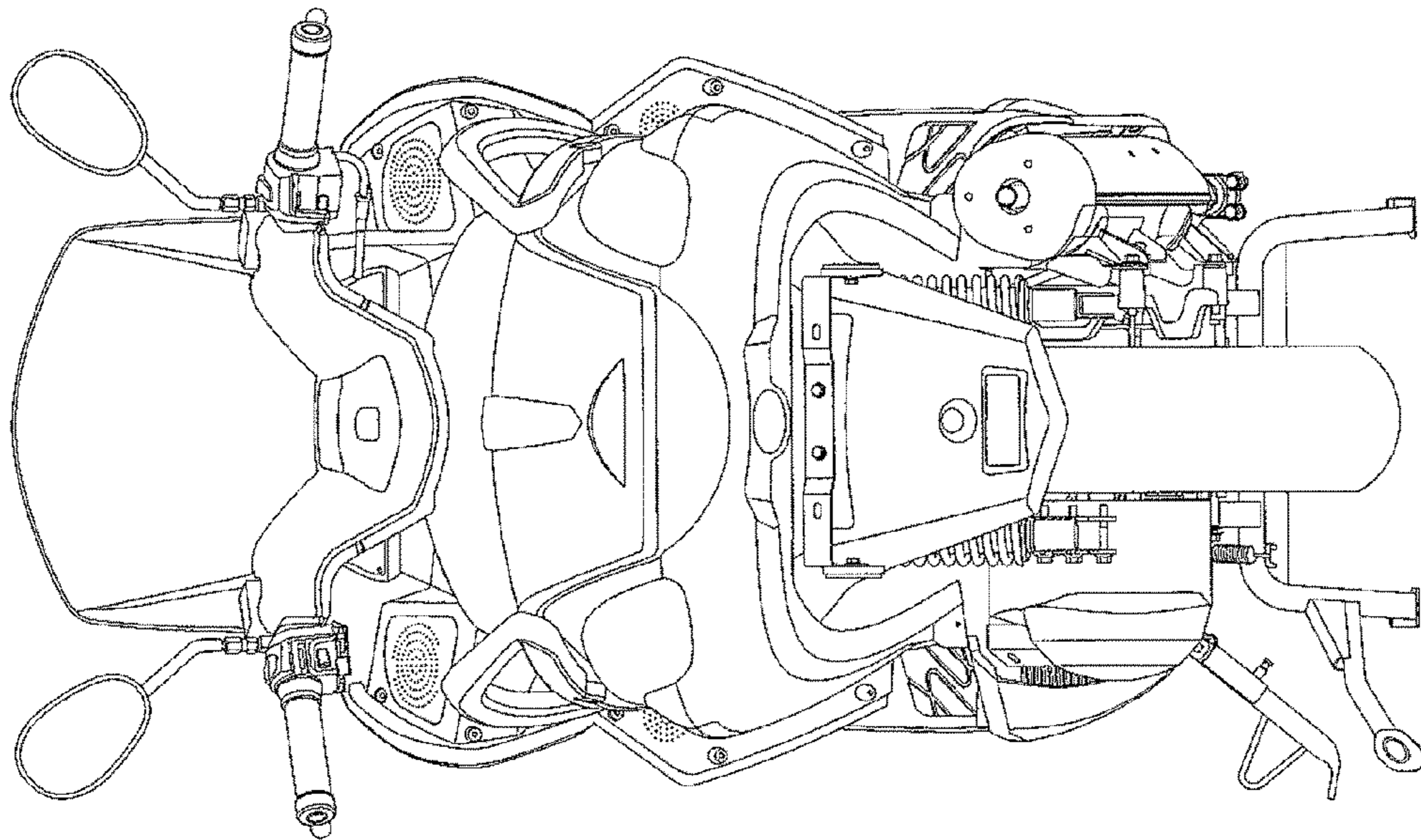

Fig. 4

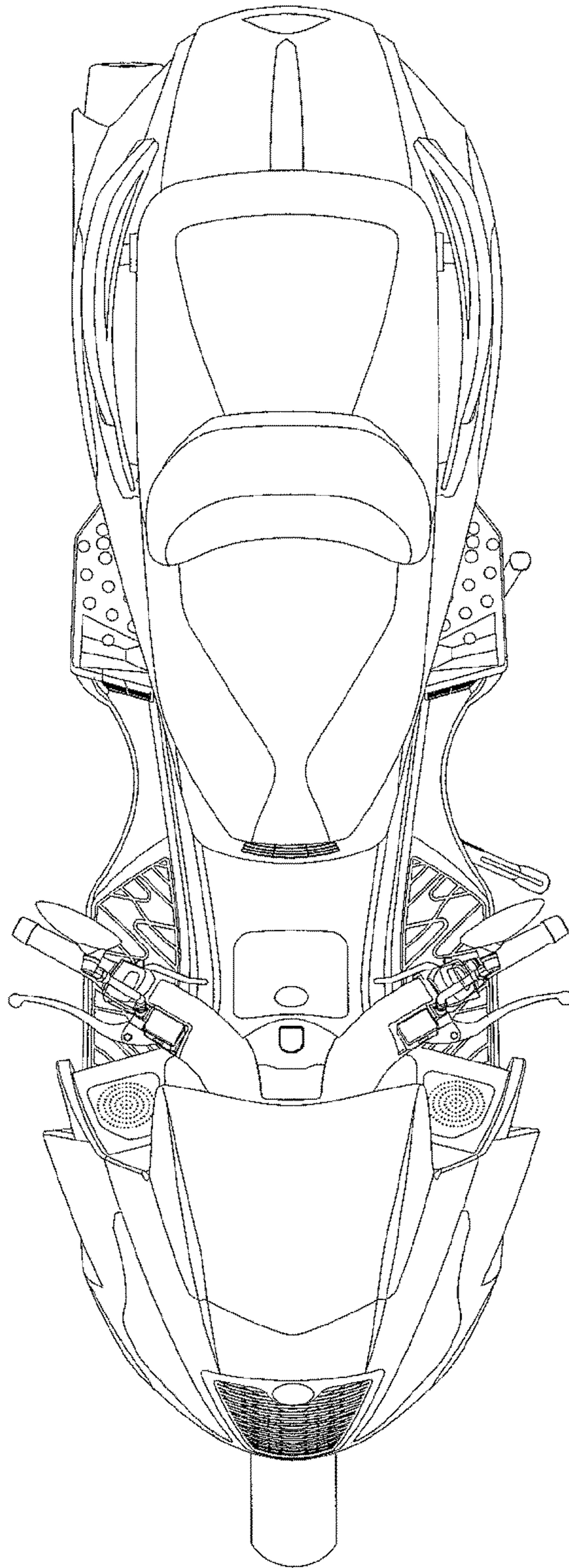

Fig. 5

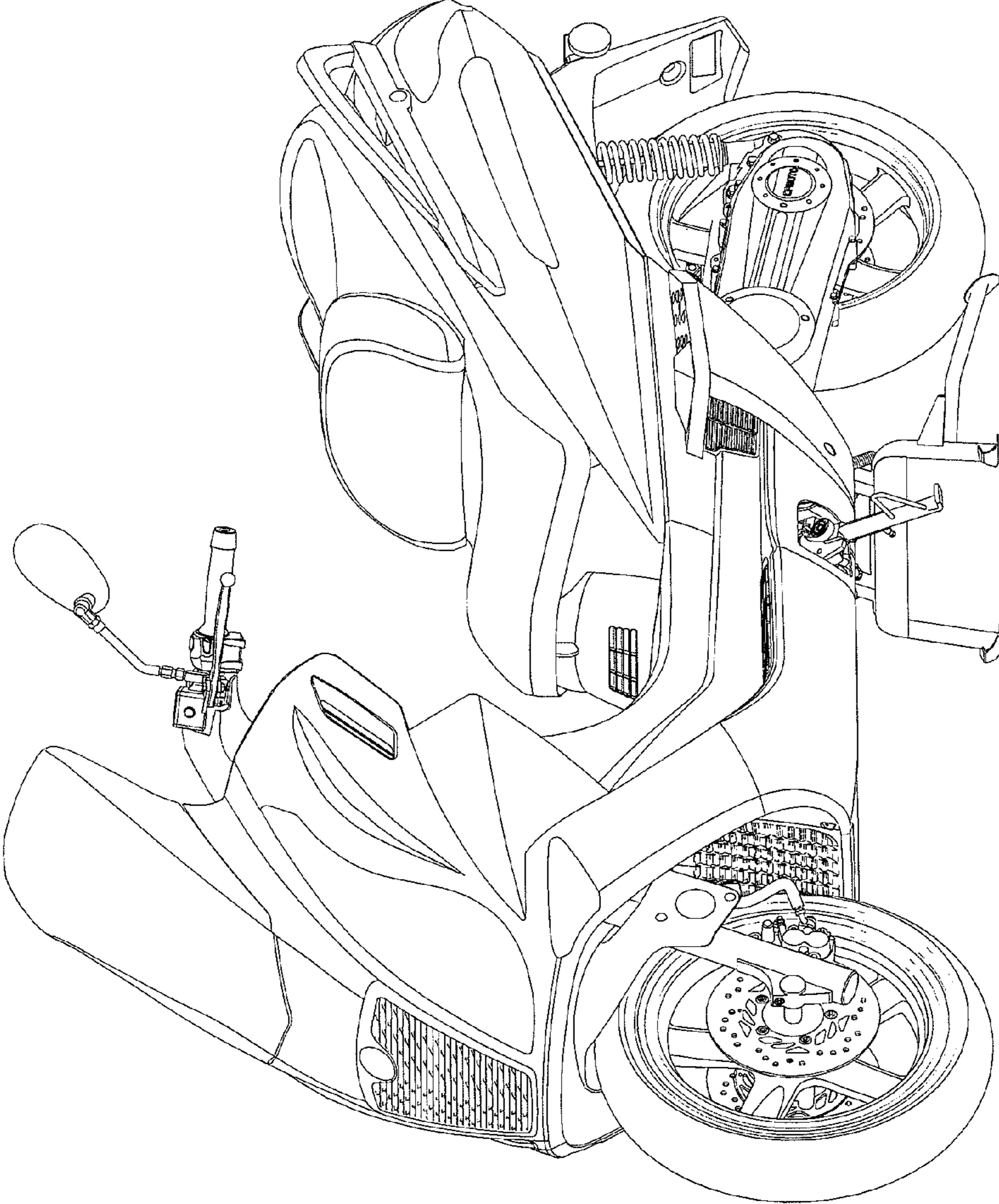

Fig. 6