



US00D650926S

(12) **United States Design Patent**
Lai et al.

(10) **Patent No.:** **US D650,926 S**

(45) **Date of Patent:** **** *Dec. 20, 2011**

(54) **LED BULB HOUSING**

(75) Inventors: **Chih-Ming Lai**, Miao-Li Hsien (TW);
Hong-Bin Yang, Miao-Li Hsien (TW)

(73) Assignee: **Foxsemicon Integrated Technology, Inc.**, Chu-Nan, Miao-Li Hsien (TW)

(*) Notice: This patent is subject to a terminal disclaimer.

(**) Term: **14 Years**

(21) Appl. No.: **29/361,843**

(22) Filed: **May 17, 2010**

(51) **LOC (9) Cl.** **26-04**

(52) **U.S. Cl.** **D26/2**

(58) **Field of Classification Search** D26/1-4;
313/313, 315, 316, 317, 318, 493; 315/52,
315/53, 56, 57, 58

See application file for complete search history.

(56) **References Cited**

U.S. PATENT DOCUMENTS

D532,532	S	*	11/2006	Maxik	D26/2
D535,038	S	*	1/2007	Egawa et al.	D26/2
D553,265	S	*	10/2007	Maxik	D26/2
D553,266	S	*	10/2007	Maxik	D26/2
D566,300	S	*	4/2008	Lo	D26/2
D584,838	S	*	1/2009	To et al.	D26/2
D620,154	S	*	7/2010	Wang et al.	D26/2

* cited by examiner

Primary Examiner — Marcus A Jackson

(74) *Attorney, Agent, or Firm* — Altis Law Group, Inc.

(57) **CLAIM**

The ornamental design for a LED bulb housing, as shown and described.

DESCRIPTION

FIG. 1 is a perspective view of an LED bulb housing showing our new design.

FIG. 2 is a front elevational view thereof.

FIG. 3 is a rear elevational view thereof.

FIG. 4 is a left-side, elevational view thereof.

FIG. 5 is a right-side, elevational view thereof.

FIG. 6 is a top plan view thereof; and,

FIG. 7 is a bottom plan view thereof.

1 Claim, 7 Drawing Sheets

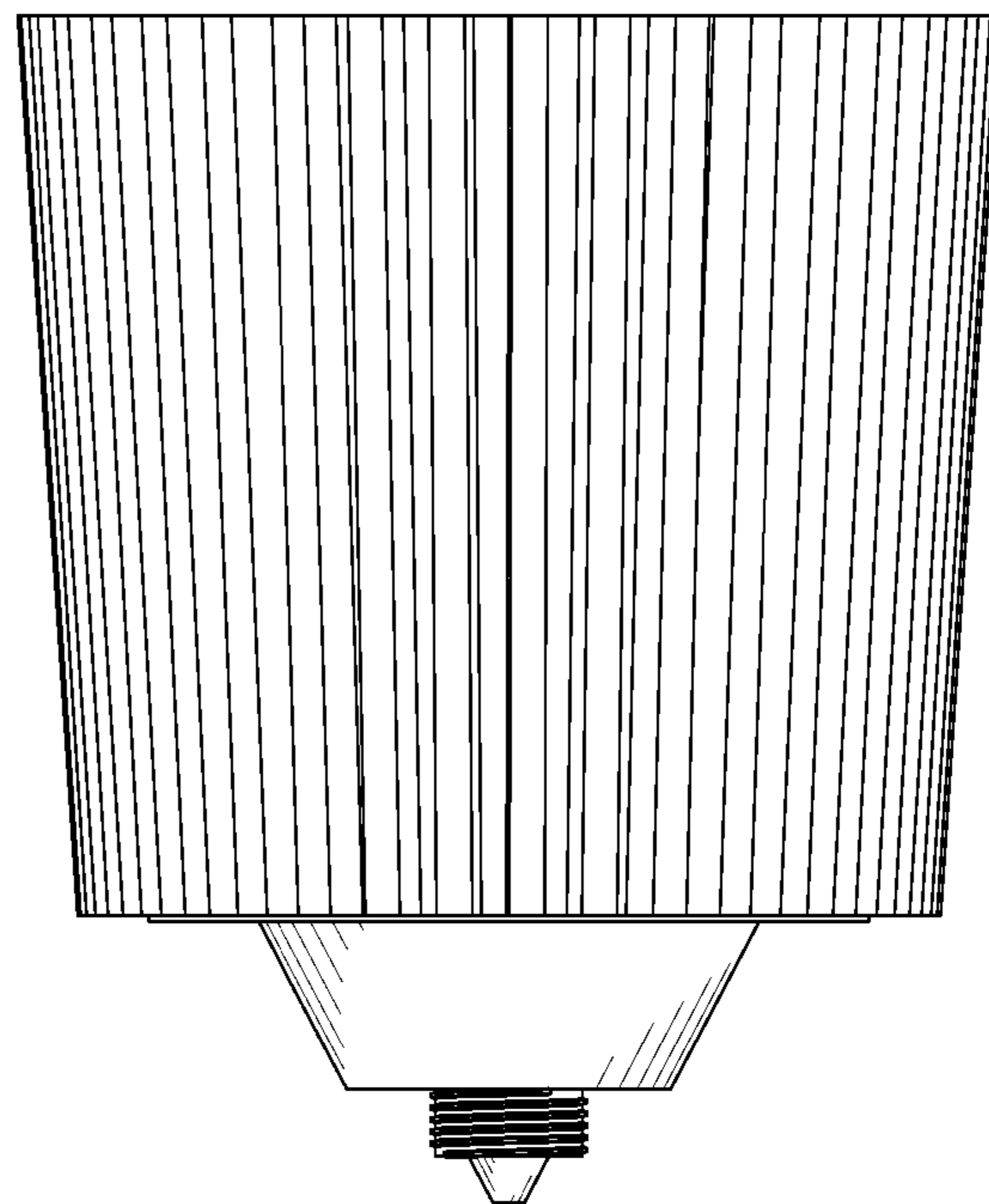
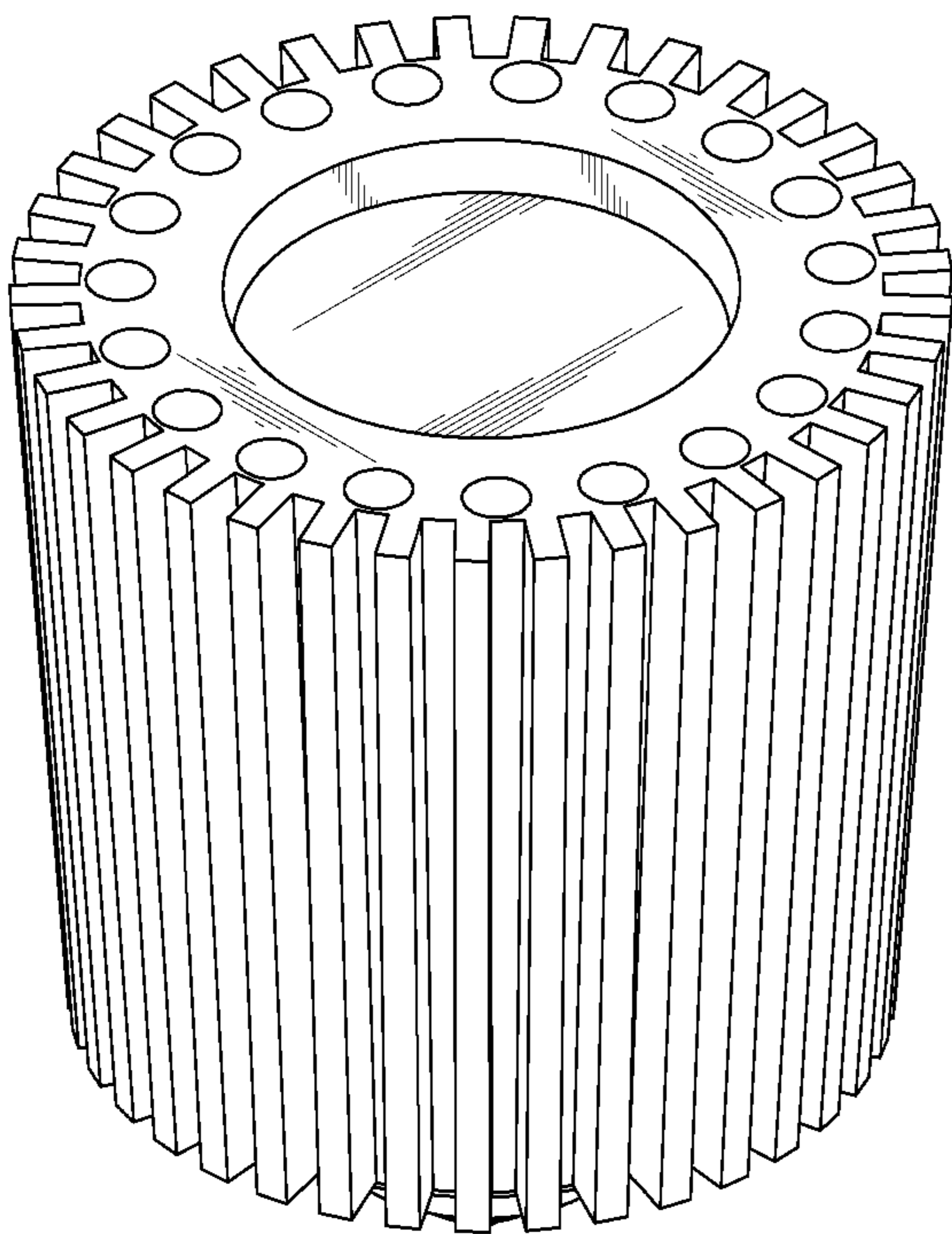

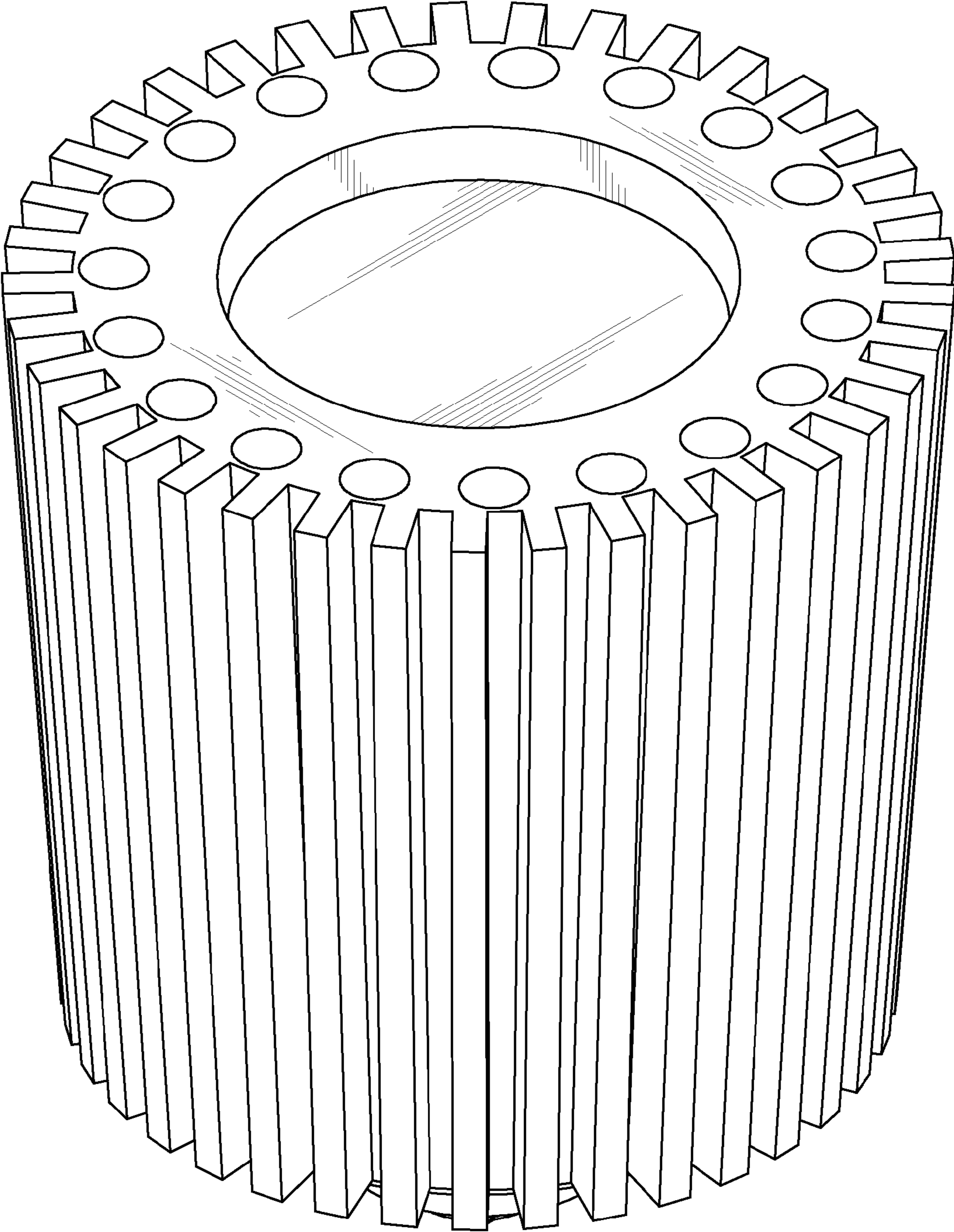

FIG. 1

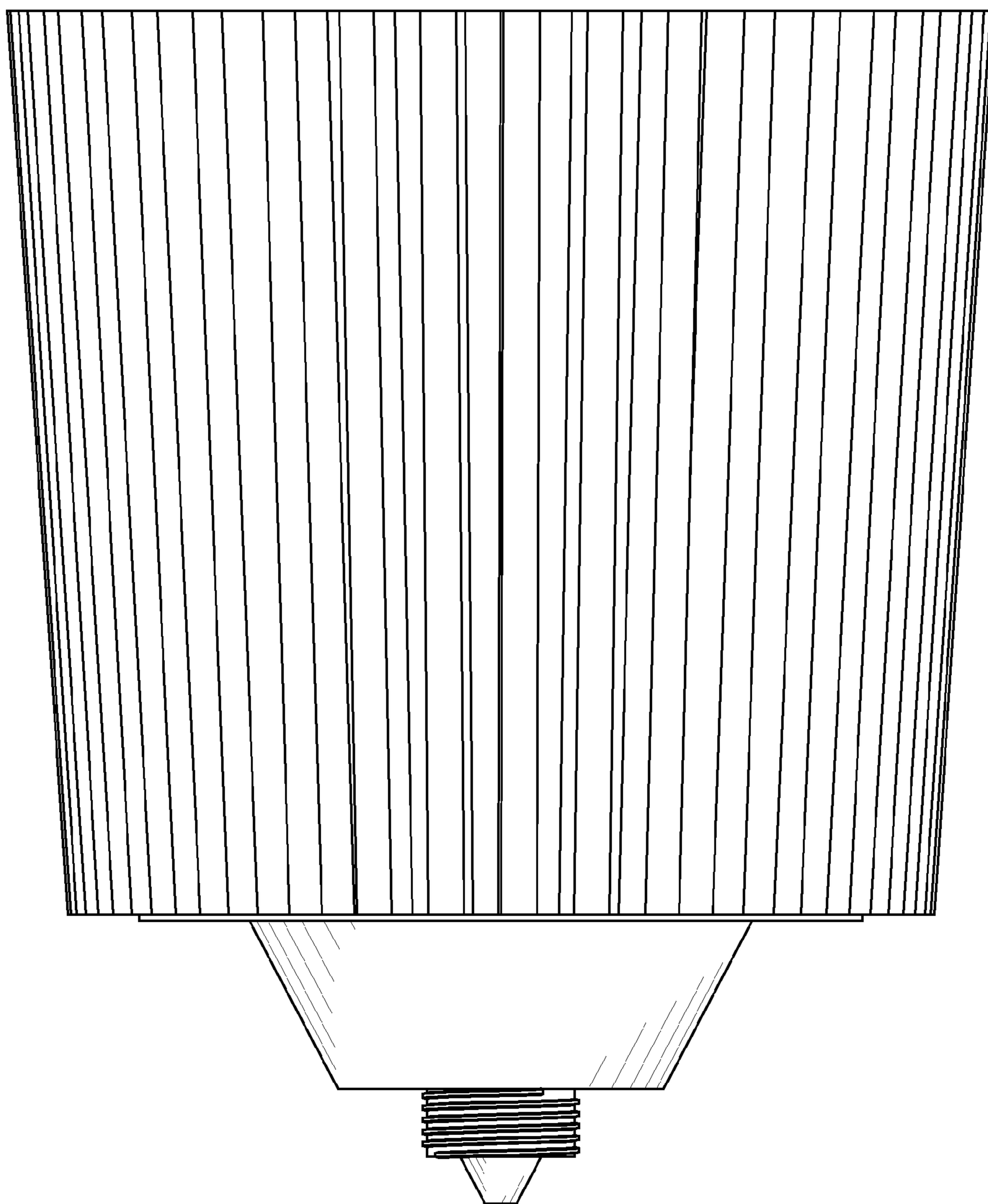

FIG. 2

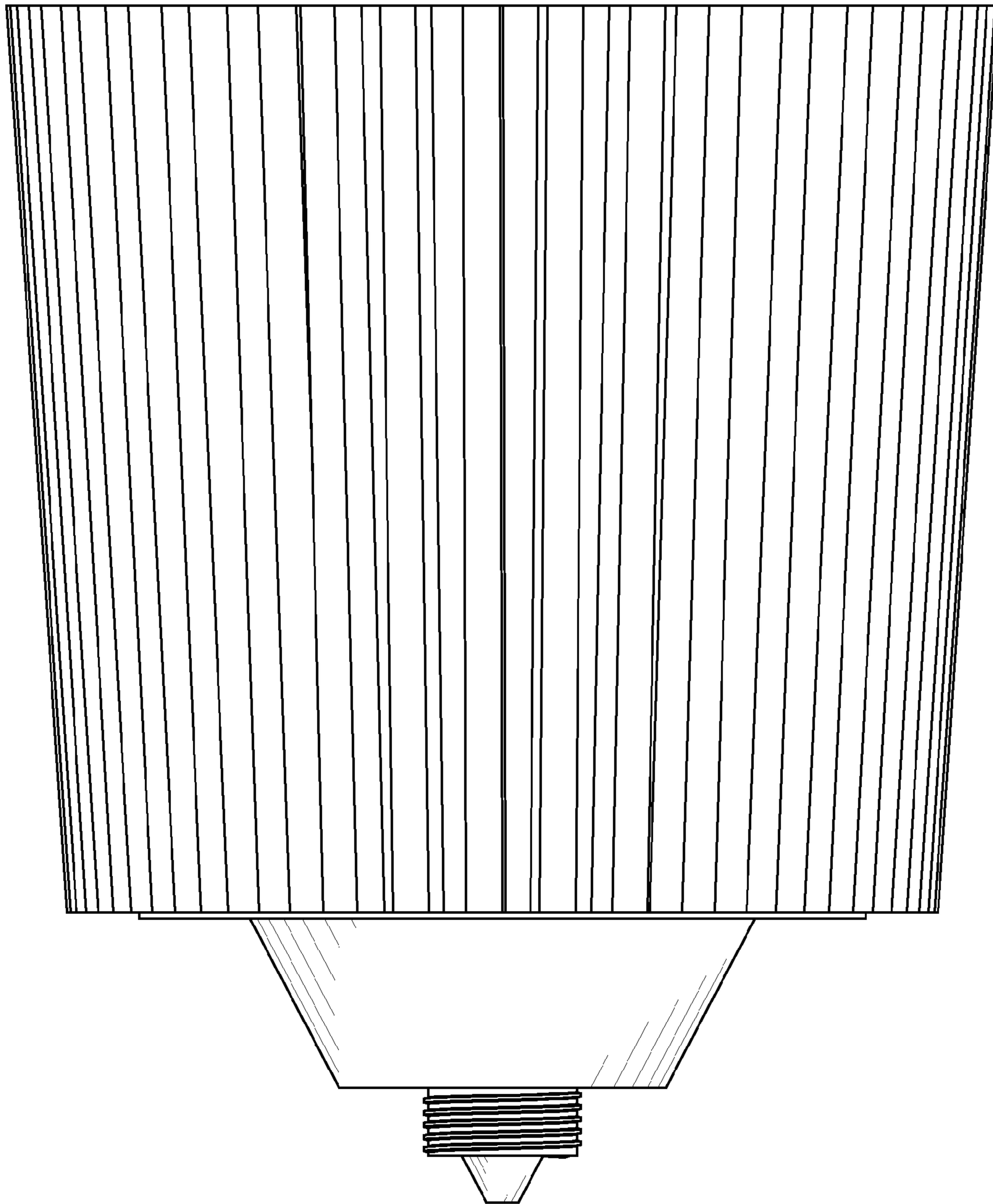

FIG. 3

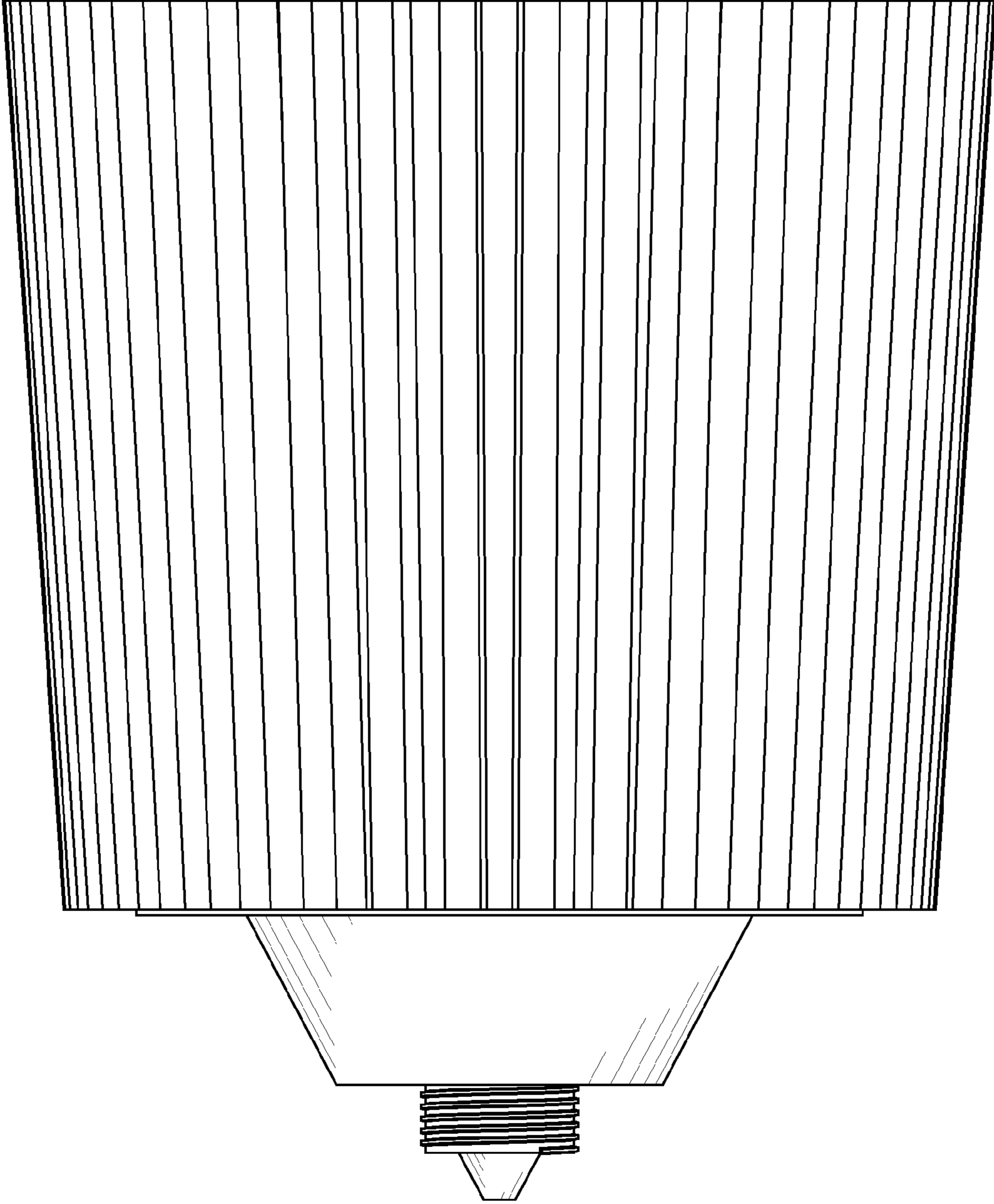

FIG. 4

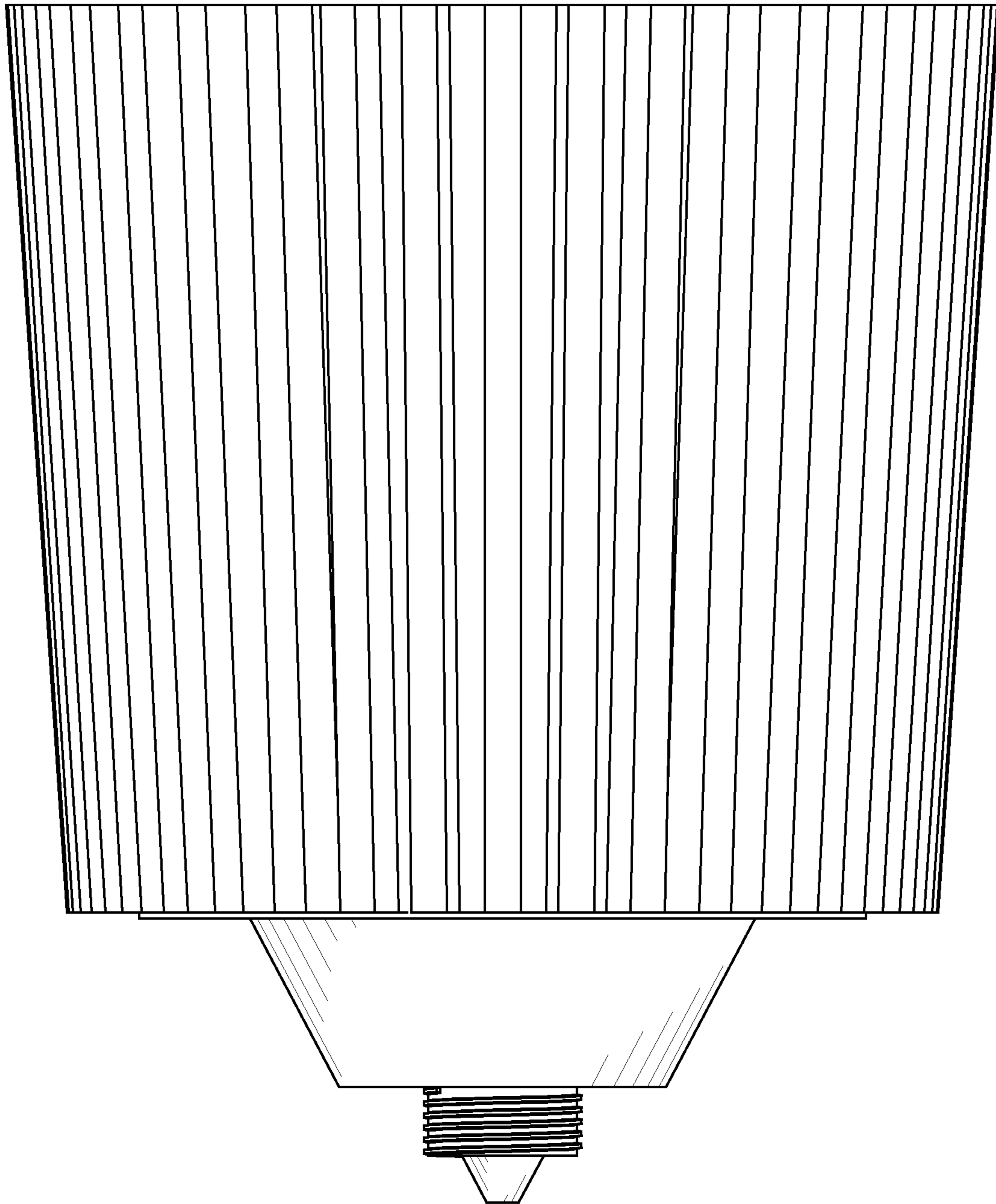

FIG. 5

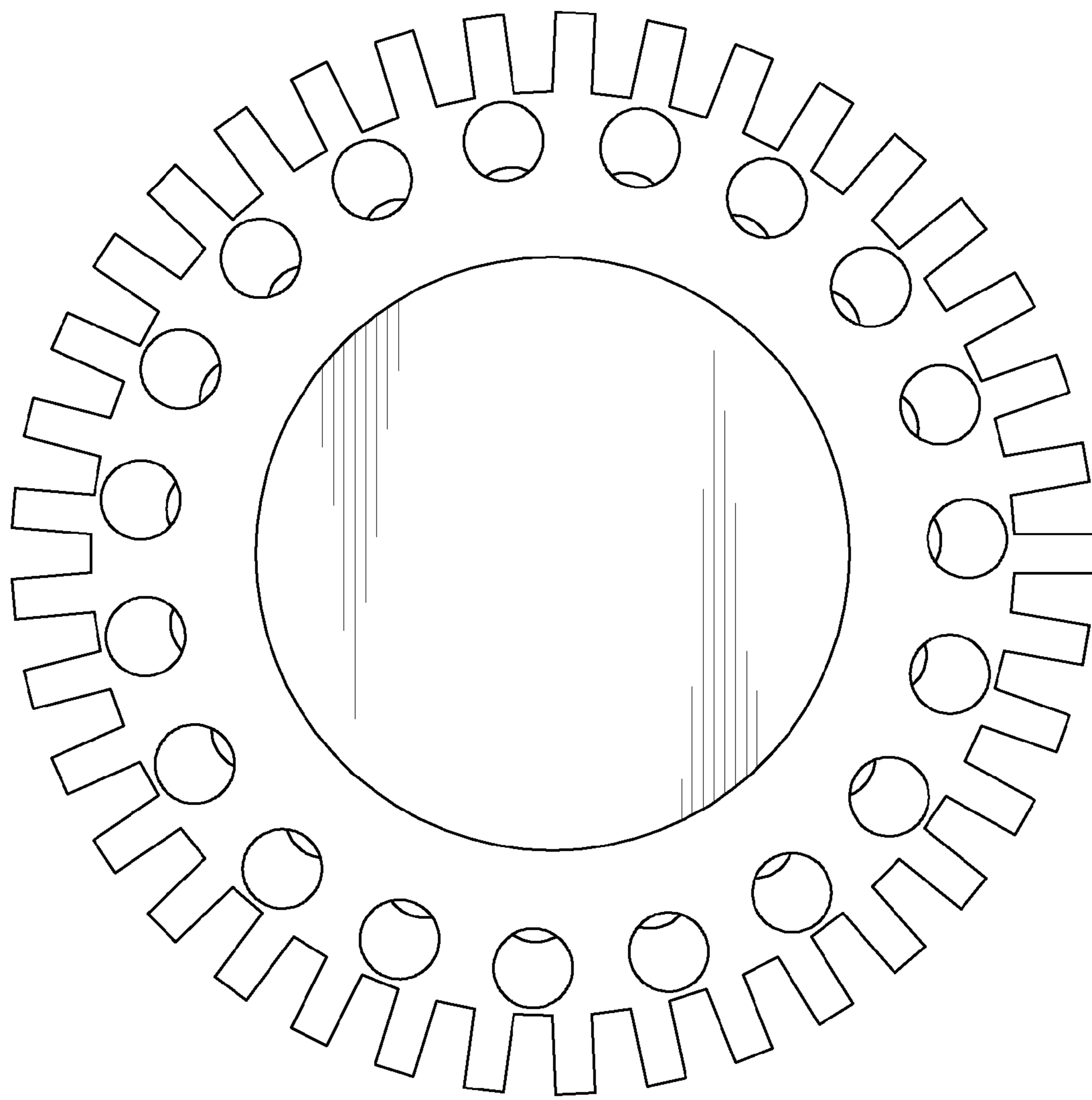

FIG. 6

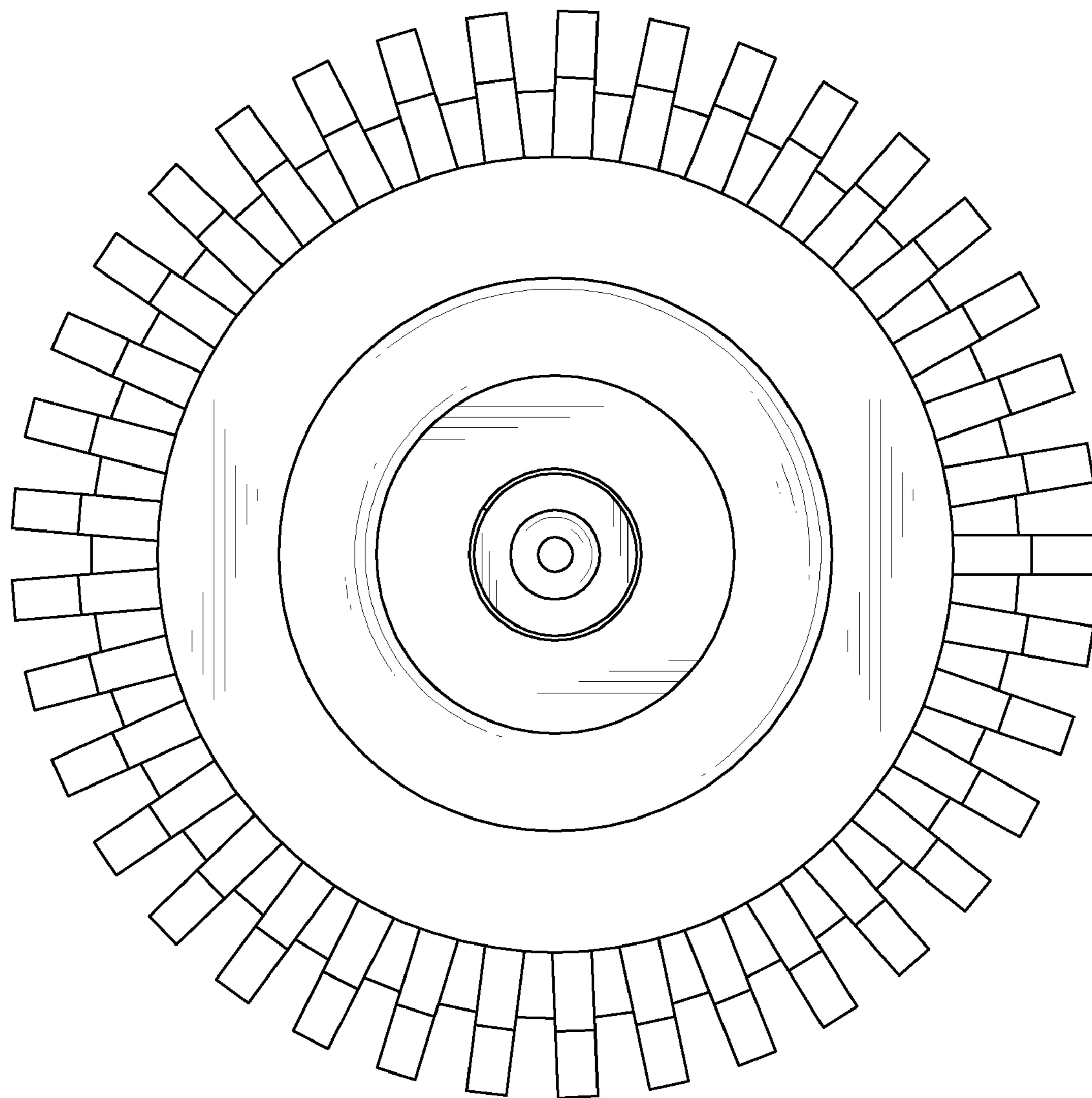

FIG. 7