



US00D650892S

(12) **United States Design Patent**
Wheatley et al.

(10) **Patent No.:** **US D650,892 S**

(45) **Date of Patent:** **** Dec. 20, 2011**

- (54) **VENT STICK AIR FRESHENER**
- (75) Inventors: **Alan J. Wheatley**, Draper, UT (US);
Aaron Irvin, Salt Lake City, UT (US)
- (73) Assignee: **American Covers, Inc.**, Bluffdale, UT (US)

- 4,149,675 A 4/1979 Van Breen et al.
- 4,184,099 A 1/1980 Lindauer et al.
- 4,226,944 A 10/1980 Stone et al.
- D258,511 S 3/1981 Ashton
- 4,301,949 A 11/1981 Palson et al.
- 1,683,545 A 9/1982 Harris
- 4,517,326 A 5/1985 Cordts et al.

(Continued)

- (**) Term: **14 Years**
- (21) Appl. No.: **29/394,683**
- (22) Filed: **Jun. 20, 2011**

FOREIGN PATENT DOCUMENTS

- CA 2077251 5/1993
- (Continued)

OTHER PUBLICATIONS

About.com Housekeeping, <http://housekeeping.about.com/od/pr...>
affresh, Febreze Noticeables, accessed Oct. 2, 2008, 2 pages.

(Continued)

Primary Examiner — Sandra Snapp
(74) *Attorney, Agent, or Firm* — Thorpe North & Western
LLP

Related U.S. Application Data

- (63) Continuation of application No. 29/378,121, filed on Oct. 29, 2010, now Pat. No. Des. 640,359, and a continuation of application No. 12/915,983, filed on Oct. 29, 2010.
- (51) **LOC (9) Cl.** **28-99**
- (52) **U.S. Cl.** **D23/366**
- (58) **Field of Classification Search** D23/355-369;
D28/5, 6; 261/DIG. 17, DIG. 42, DIG. 65,
261/DIG. 88, DIG. 89; 392/386, 390-395;
239/34, 35, 44-47, 50, 53, 56, 60, 145, 326
See application file for complete search history.

(57) **CLAIM**
The ornamental design for the vent stick air freshener, as shown and described.

(56) **References Cited**

U.S. PATENT DOCUMENTS

- D176,671 S 4/1876 Myers
- D140,109 S 1/1945 Pierce
- 2,642,248 A 6/1953 Semon
- 2,733,333 A 1/1956 Peters
- D177,826 S 5/1956 Katz
- D178,237 S 7/1956 Katz
- 3,456,106 A 7/1969 Glusckin Mischa
- 3,655,129 A 4/1972 Seiner
- 3,847,305 A 11/1974 Tobin
- 3,948,445 A 4/1976 Andeweg
- 3,971,858 A 7/1976 Collier et al.
- D250,041 S 10/1978 Schimanski

DESCRIPTION

FIG. 1 is a rear perspective view of the vent stick air freshener in accordance with my invention;
FIG. 2 is a top plan view thereof;
FIG. 3 is a bottom plan view thereof;
FIG. 4 is a right side elevation view thereof;
FIG. 5 is a left side elevation view thereof;
FIG. 6 is a rear elevation view thereof; and,
FIG. 7 is a front elevation view thereof.
The broken lines shown in FIGS. 1-7 are for illustrative purposes only and form no part of the claimed design.

1 Claim, 2 Drawing Sheets

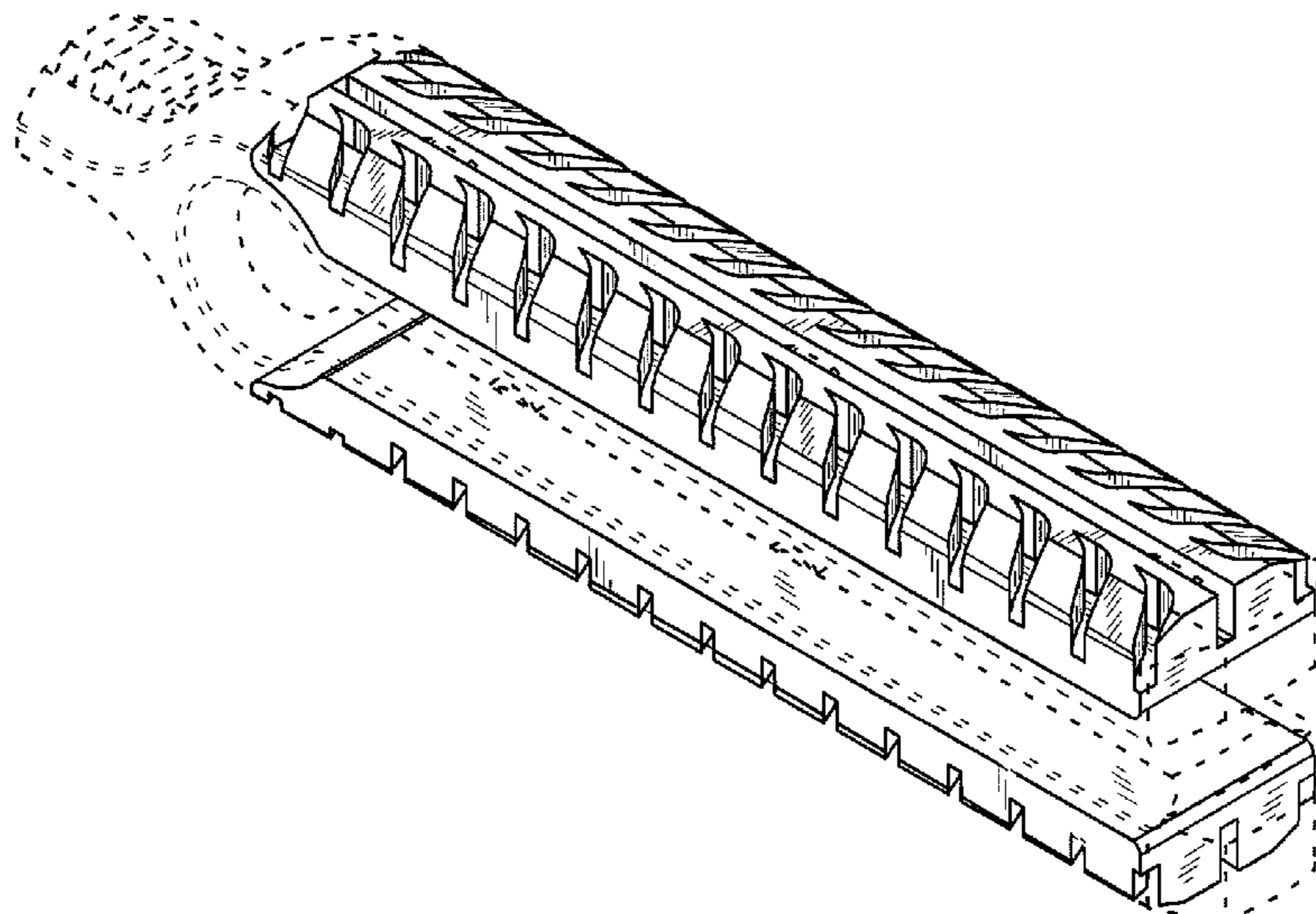

Medo® Air Fresheners; Auto Expressions™ 2005 Product Catalog; 25 pages.

Pictures (3) of Medo® auto Expressions Vent™ Air Freshener distributed by SOPUS Products of Moorpark, CA 2003 copyright date on package.

Scents & Sprays, www.scentsandsprays.com/ya..., Yankee Autumn Bounty Electric 2 Home Air Fresheners, copyright 2001-2008 scentsandsprays.com, accessed Oct. 2, 2008, 1 page.

U.S. Appl. No. 12/915,924; filed Oct. 29, 2010; Nathaniel Finlay.

U.S. Appl. No. 12/915,983; filed Oct. 29, 2010; Alan J. Wheatley.

U.S. Appl. No. 12/916,038; filed Oct. 29, 2010; Aaron Irvin.

U.S. Appl. No. 12/979,763; filed Dec. 28, 2010; Aaron Irvin.

U.S. Appl. No. 12/979,795; filed Dec. 28, 2010; Aaron Irvin.

U.S. Appl. No. 12/979,813; filed Dec. 28, 2010; Aaron Irvin.

U.S. Appl. No. 13/009,574; filed Jan. 19, 2011; Alan J. Wheatley.

U.S. Appl. No. 29/378,116; filed Oct. 29, 2010; Aaron Irvin.

www.4imprint.com/Exec/Detail/FromProductGroup/~SKU100300/~CA100300.htm, Hot Rod Vent Stick Air Freshener (it . . . , accessed Aug. 12, 2008, 2 pages.

www.autothing.com/Products/Air%20Fresheners/air%20freshener-clip.htm, Air Fresheners, Fresh Scents for you mobile Life, Clip-on Air Vent Clips rom Eagle o., Accessed Aug. 12, 2008, 1 page.

www.chicscents.com/Products.aspx Island Adventure Sandals; 2 pages; accessed Feb. 1, 2011.

www.chicscents.com/Products.aspx; Inspiration 3-D by Chic; 2 pages; accessed Feb. 1, 2011.

U.S. Appl. No. 13/191,966; filing date Jul. 27, 2011; Aaron Irvin.

* cited by examiner

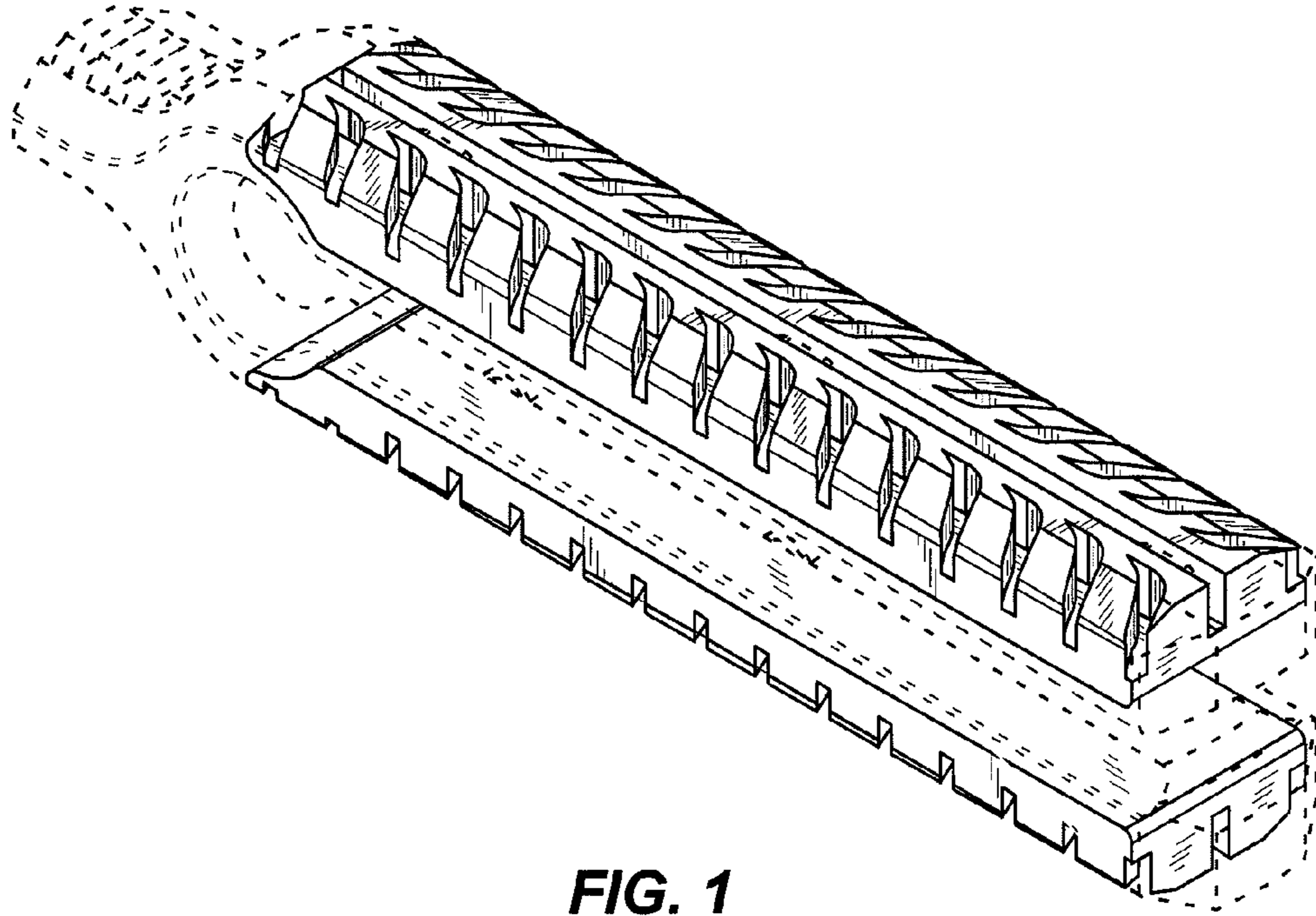

FIG. 1

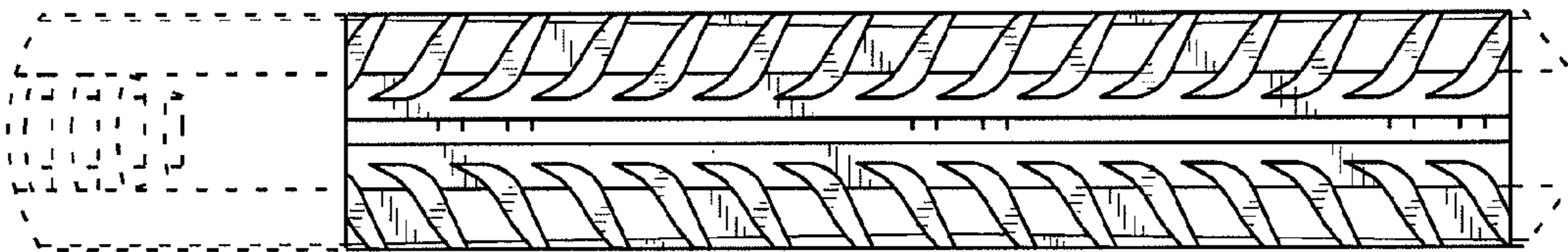

FIG. 2

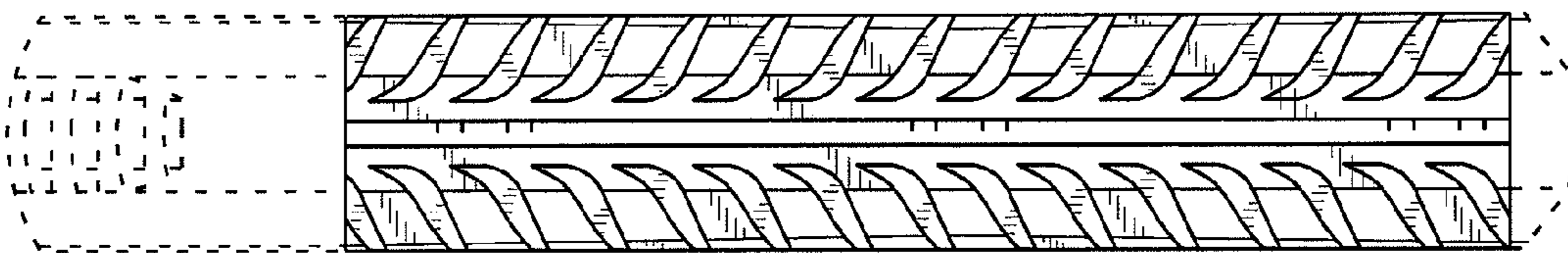

FIG. 3

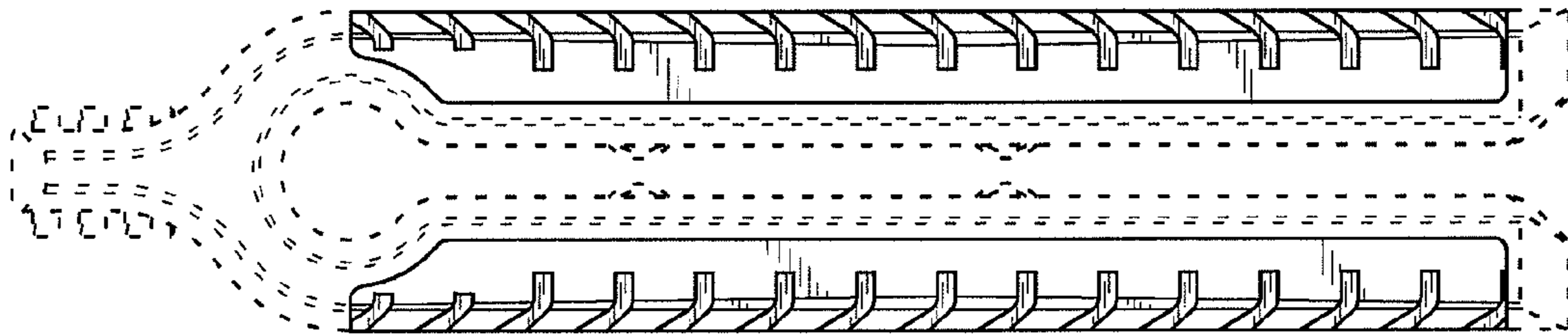

FIG. 4

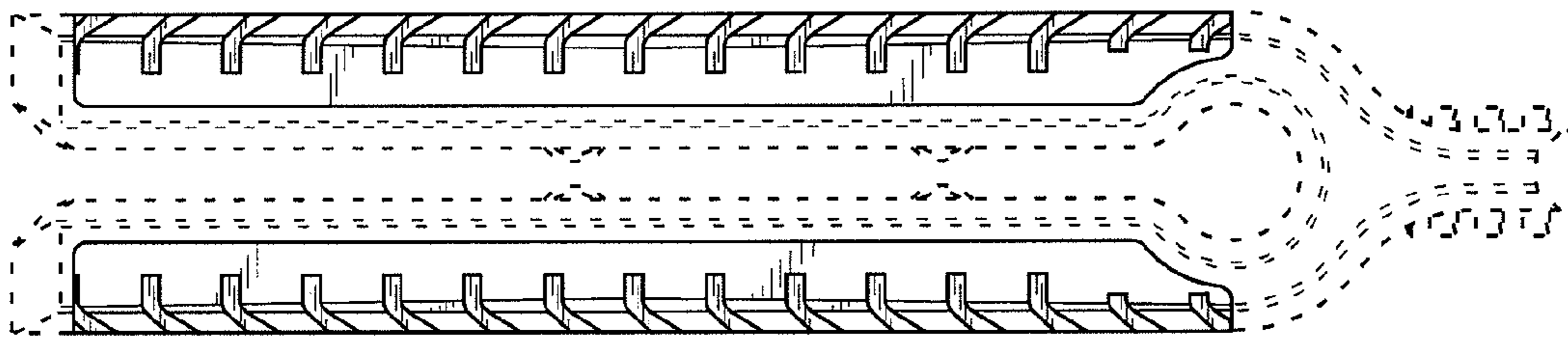

FIG. 5

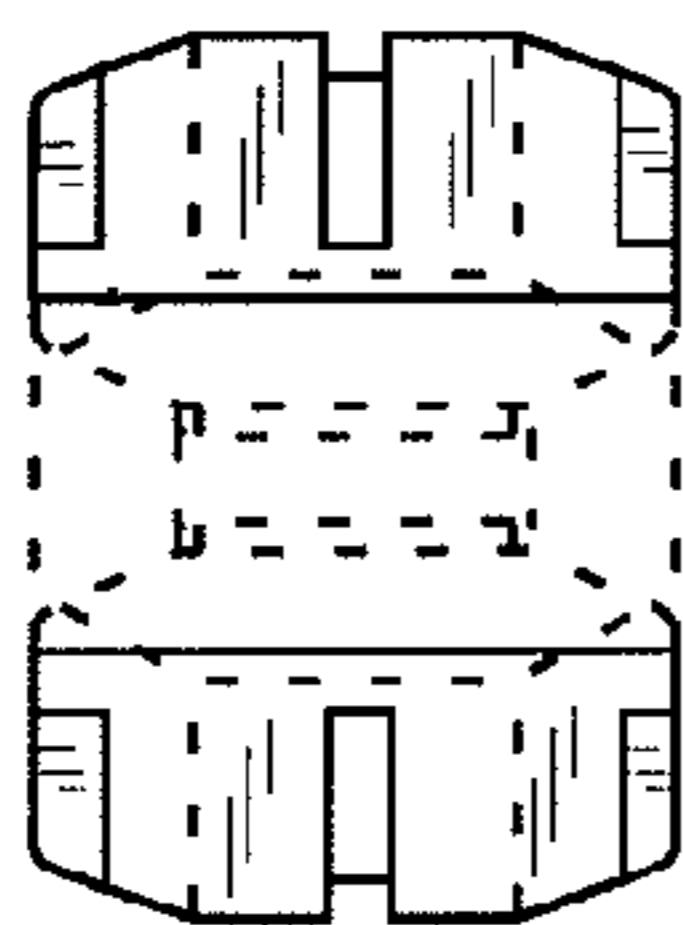

FIG. 6

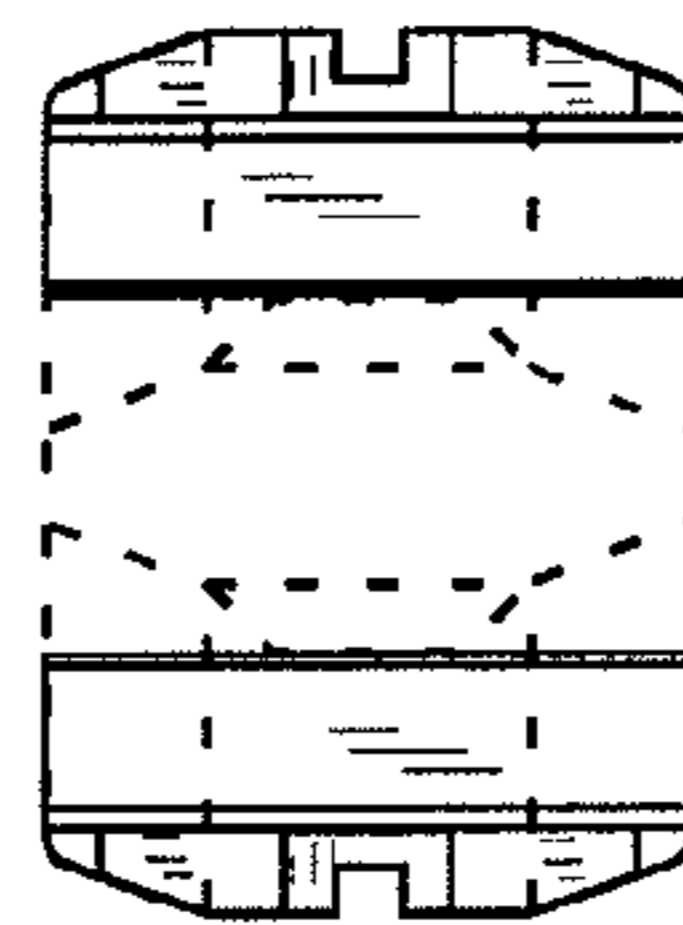

FIG. 7