



US00D650814S

(12) **United States Design Patent**  
**Brown et al.**

(10) **Patent No.:** **US D650,814 S**

(45) **Date of Patent:** **\*\* Dec. 20, 2011**

(54) **PORTABLE WATER PUMPING STATION**

(75) Inventors: **Dennis B. Brown**, Logan, UT (US);  
**Richard O. Evans**, Hyrum, UT (US);  
**Gary A. Cruikshank**, Ferndale, WA (US)

(73) Assignee: **Aquamira Technologies, Inc.**, Logan, UT (US)

(\*\*) Term: **14 Years**

(21) Appl. No.: **29/383,590**

(22) Filed: **Jan. 19, 2011**

(51) **LOC (9) Cl.** ..... **15-02**

(52) **U.S. Cl.** ..... **D15/7; D23/200**

(58) **Field of Classification Search** ..... D15/7-9;  
D23/231, 232, 225, 200; 417/60, 235, 265,  
417/321, 355, 358, 363, 359, 410.1, 415-416,  
417/405, 900; 60/408, 412; 184/26-37;  
415/140-147; 123/495, 509; 239/74, 113,  
239/146, 198, 732

See application file for complete search history.

(56) **References Cited**

**U.S. PATENT DOCUMENTS**

D438,876 S \* 3/2001 Clivio ..... D15/7  
D497,915 S \* 11/2004 Bowen ..... D15/7

D499,115 S \* 11/2004 Tatic ..... D15/7  
D555,669 S \* 11/2007 Preston ..... D15/7  
D611,867 S \* 3/2010 Peterson et al. .... D15/7  
D639,311 S \* 6/2011 Peterson et al. .... D15/7

\* cited by examiner

*Primary Examiner* — Ralf Seifert

(74) *Attorney, Agent, or Firm* — Holme Roberts & Owens LLP

(57) **CLAIM**

The ornamental design for a portable water pumping station, as shown and described.

**DESCRIPTION**

FIG. 1 is an isometric view of an embodiment of a portable water pumping station;  
FIG. 2 is a front-view of the embodiment of the portable water pumping station in FIG. 1;  
FIG. 3 is a top-view of the embodiment of the portable water pumping station in FIG. 1;  
FIG. 4 is a side-view of the embodiment of the portable water pumping station in FIG. 1;  
FIG. 5 is a back-view of the embodiment of the portable water pumping station in FIG. 1; and,  
FIG. 6 is a bottom-view of the embodiment of the portable water pumping station in FIG. 1.

**1 Claim, 6 Drawing Sheets**

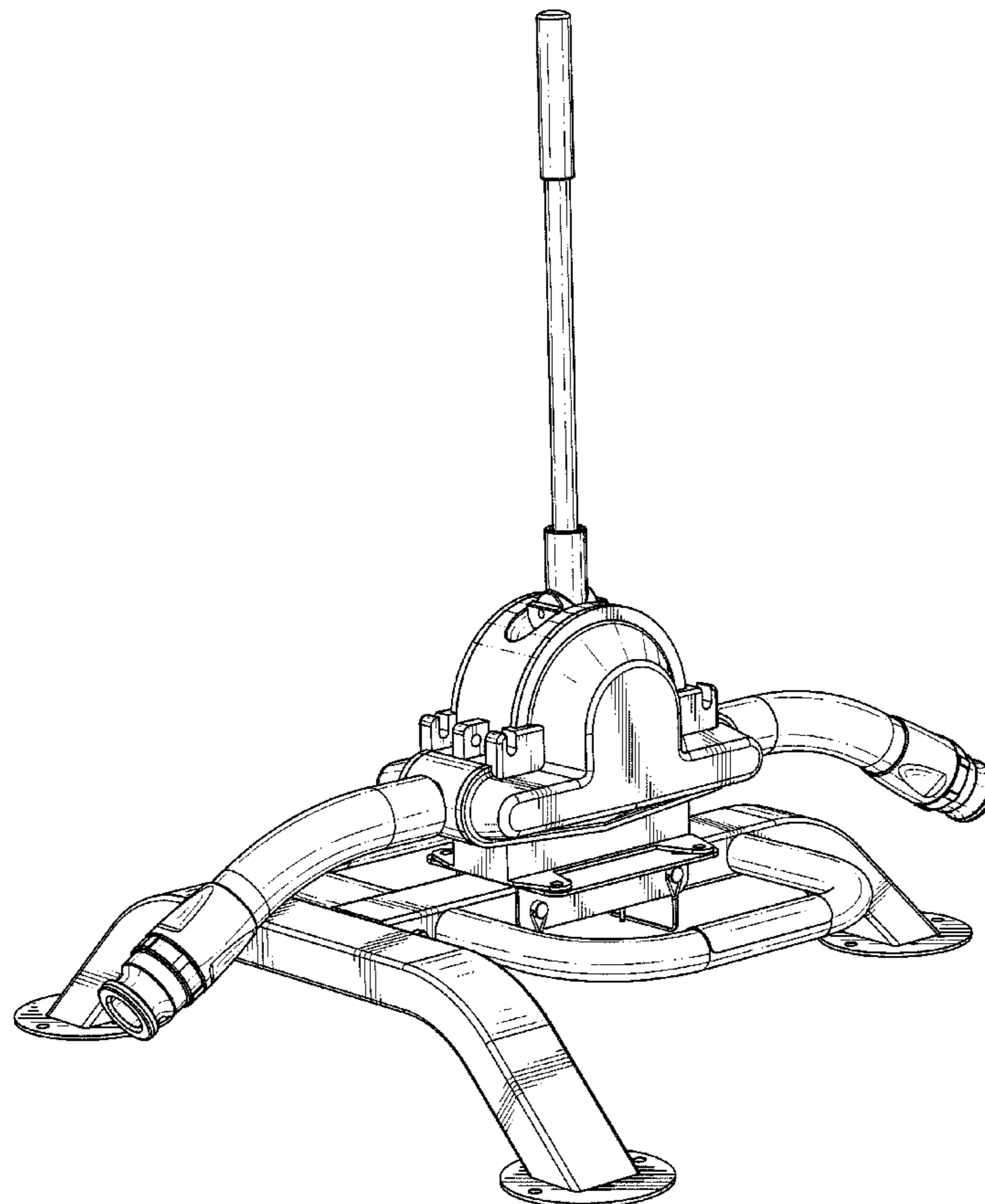

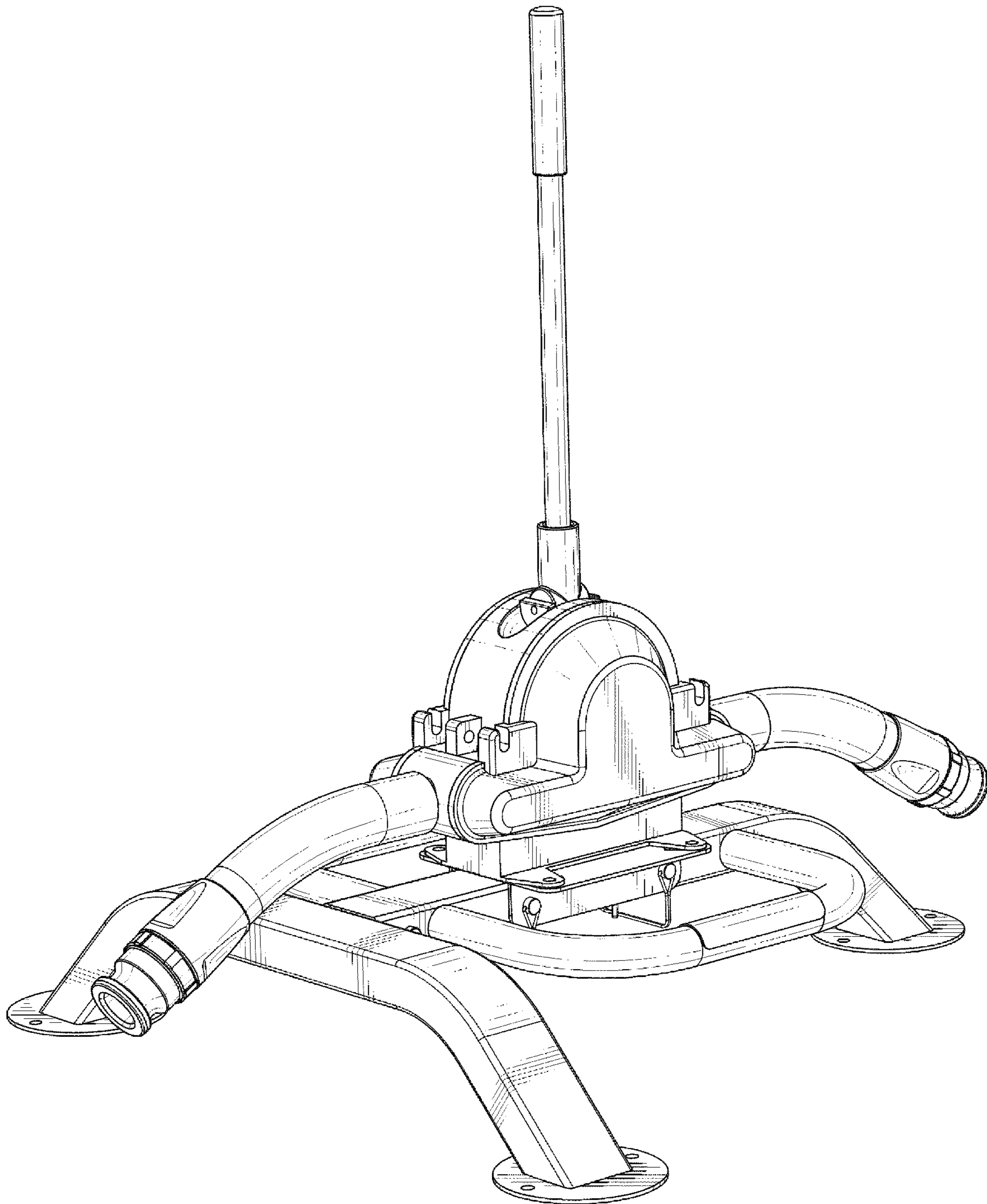

**FIG. 1**

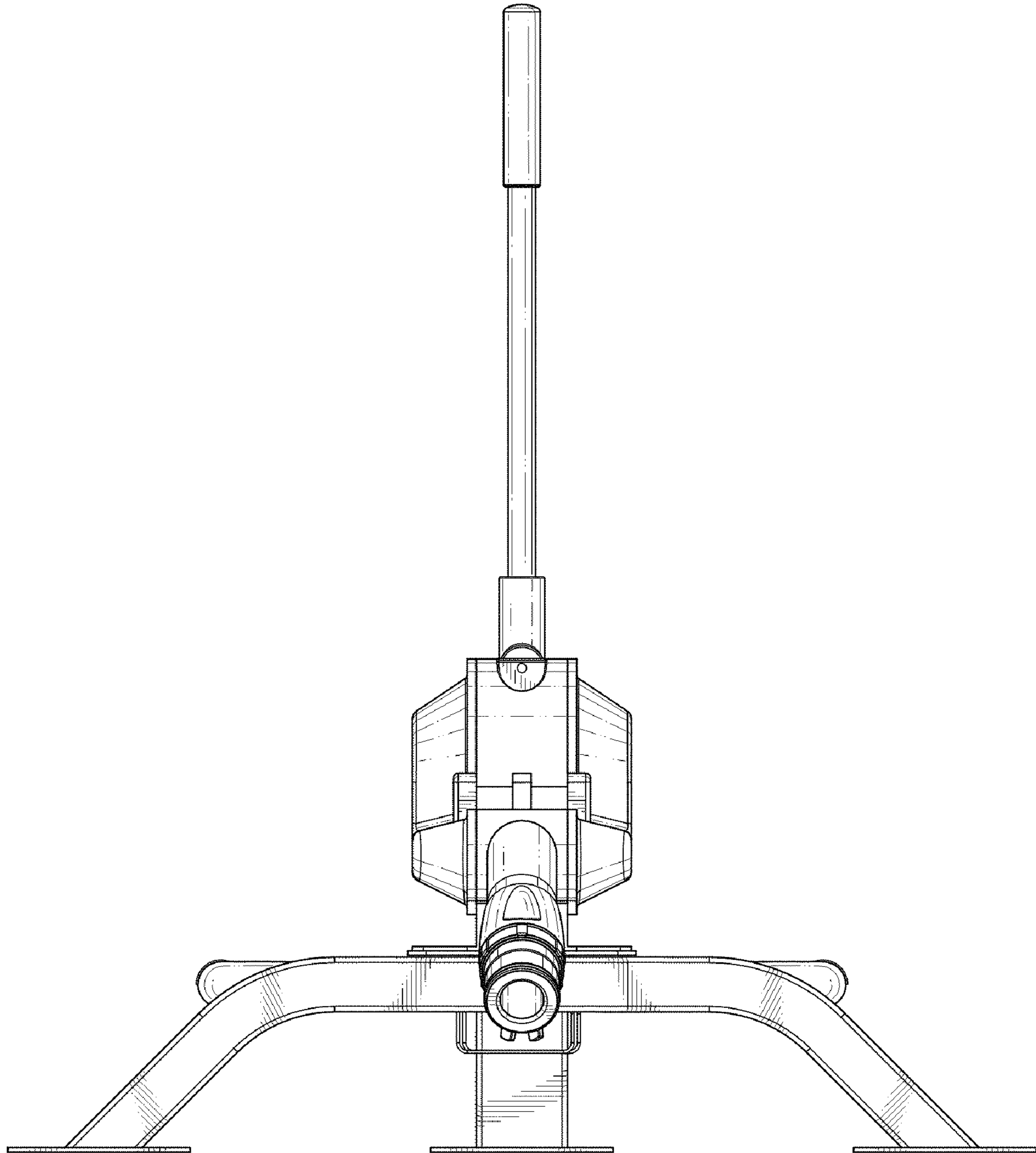

**FIG. 2**

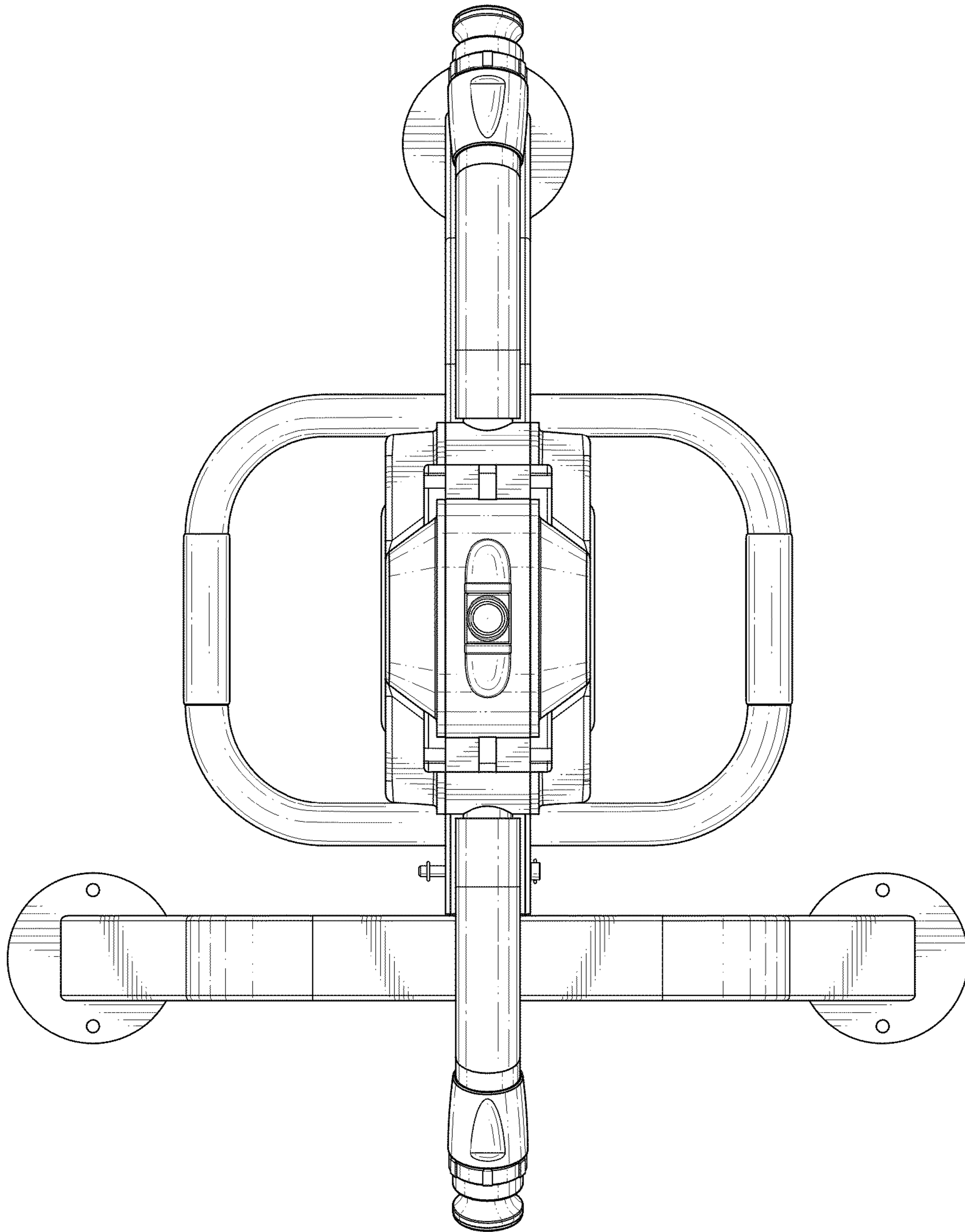

FIG. 3

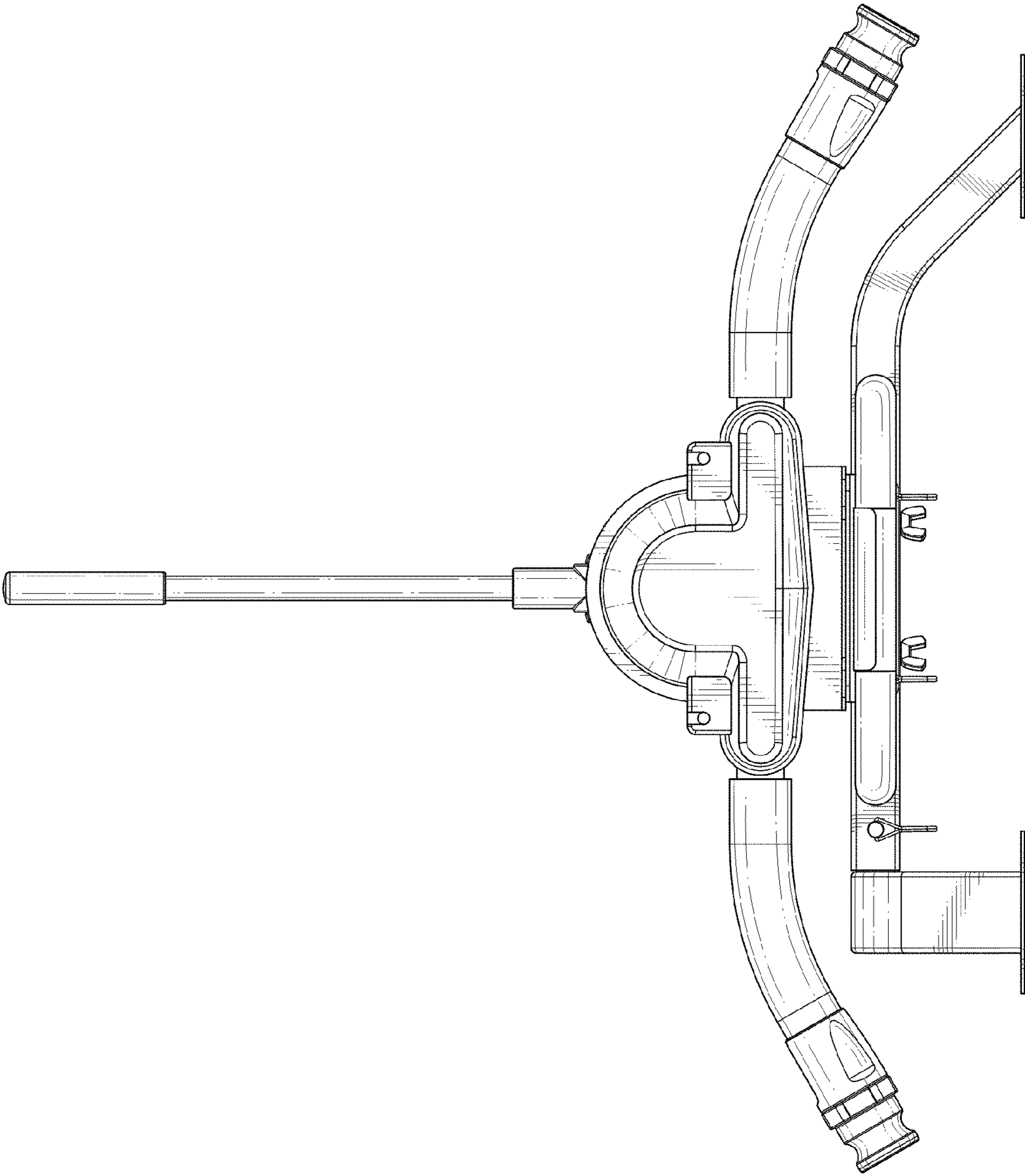
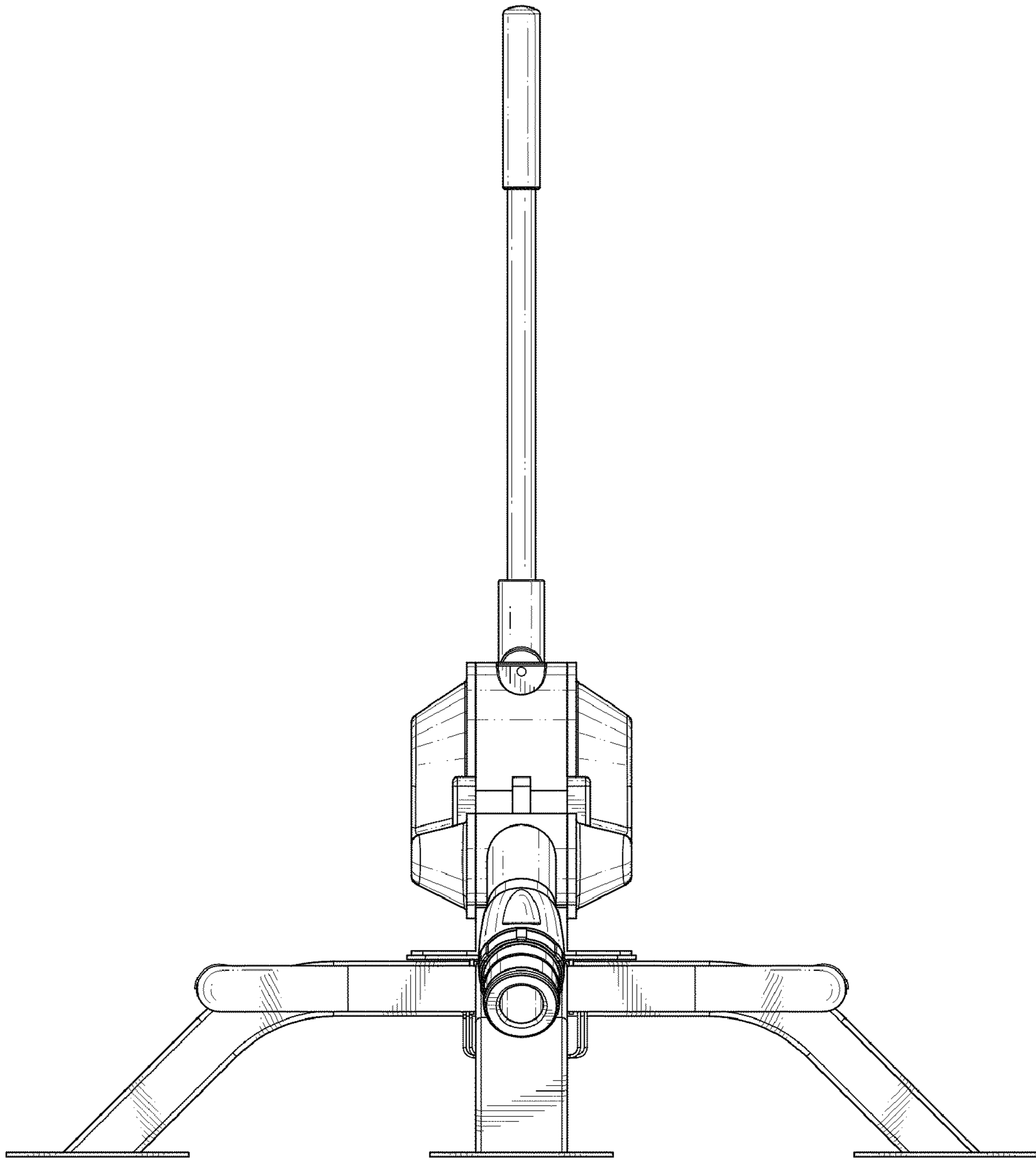

FIG. 4



**FIG. 5**

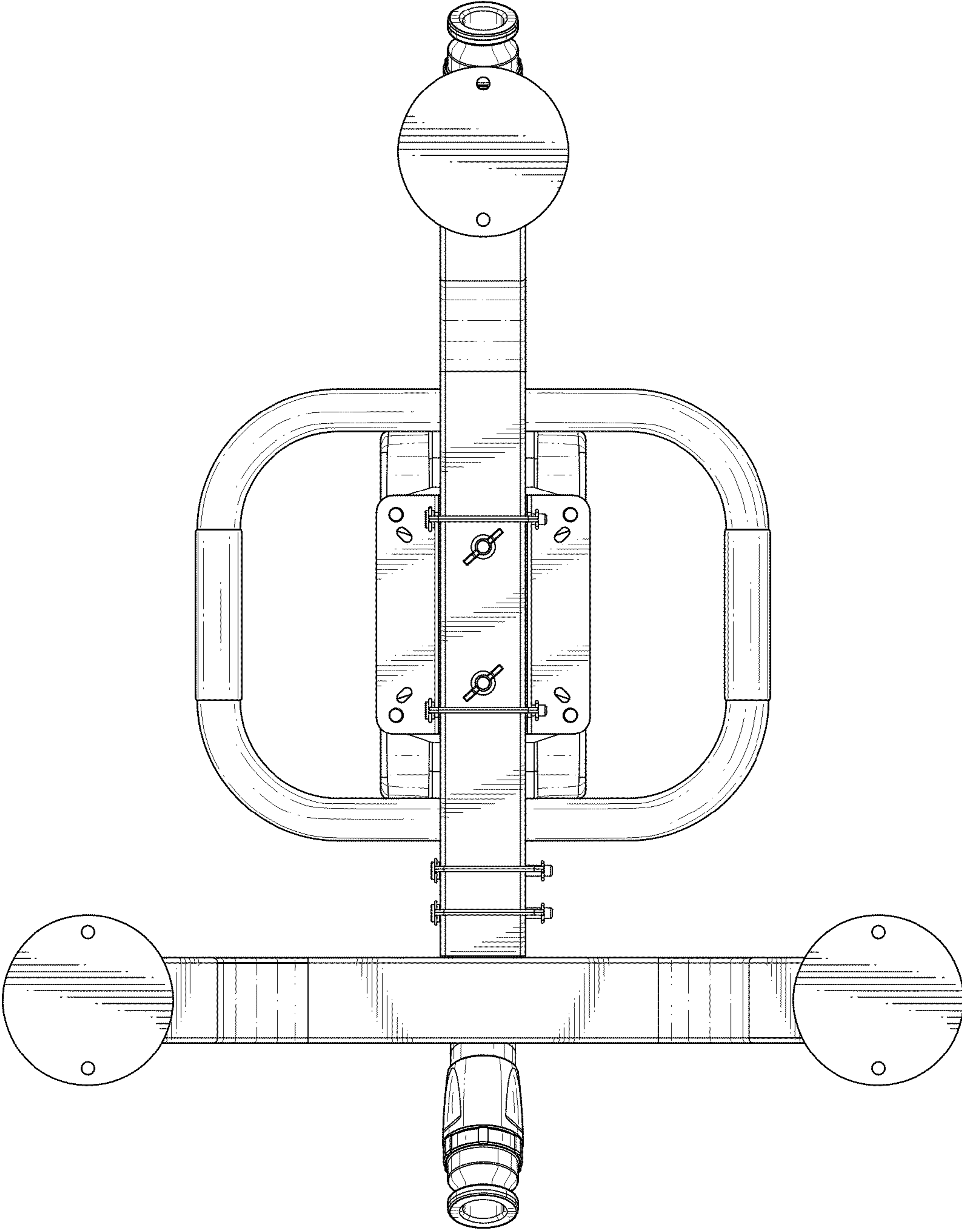

FIG. 6