



US00D650728S

(12) **United States Design Patent**  
**Mayrand et al.**

(10) **Patent No.:** **US D650,728 S**

(45) **Date of Patent:** **\*\* Dec. 20, 2011**

(54) **DASHBOARD FOR A WATERCRAFT**

(75) Inventors: **Jacques Mayrand**, Sherbrooke (CA);  
**Luc Quirin**, Bolton (CA); **Alexandre**  
**Curthelet**, Granby (CA)

(73) Assignee: **BRP US Inc.**, Sturtevant, WI (US)

(\*\*) Term: **14 Years**

(21) Appl. No.: **29/352,657**

(22) Filed: **Dec. 23, 2009**

(51) **LOC (9) Cl.** ..... **12-16**

(52) **U.S. Cl.** ..... **D12/192**

(58) **Field of Classification Search** ..... D12/192,  
D12/415, 110, 114; 280/750-752; 180/90;  
296/70, 191, 190.01-190.09; D15/28, 17;  
D10/122-127, 102-103, 98, 46  
See application file for complete search history.

(56) **References Cited**

**U.S. PATENT DOCUMENTS**

D154,611 S *	7/1949	Lauer	.....	D12/192
D291,983 S *	9/1987	Cornwell	.....	D12/192
D514,995 S *	2/2006	Acton et al.	.....	D12/192
D519,893 S *	5/2006	Kabayama et al.	.....	D12/192
D595,198 S *	6/2009	Woodard et al.	.....	D12/192
D613,653 S *	4/2010	Money Penny et al.	.....	D12/192
D613,654 S *	4/2010	Money Penny et al.	.....	D12/192
D619,947 S *	7/2010	Tirey et al.	.....	D12/192
D628,130 S *	11/2010	Miyaniishi	.....	D12/192
D635,073 S *	3/2011	Nield	.....	D12/192
D641,674 S *	7/2011	Kim et al.	.....	D12/192

\* cited by examiner

*Primary Examiner* — Caron D Veynar

*Assistant Examiner* — Katrina Kile

(74) *Attorney, Agent, or Firm* — Osler, Hoskin & Harcourt LLP

(57) **CLAIM**

The ornamental design for a dashboard for a watercraft, as shown and described.

**DESCRIPTION**

FIG. 1 is a front, bottom perspective view showing a dashboard for a watercraft according to our design;  
FIG. 2 is a right side elevation view thereof;  
FIG. 3 is a left side elevation view thereof;  
FIG. 4 is a top plan view thereof;  
FIG. 5 is a front elevation view thereof;  
FIG. 6 is a front, bottom perspective view thereof;  
FIG. 7 is a front, top, left perspective view thereof;  
FIG. 8 is a front, top, left perspective view of the dashboard for a watercraft of FIG. 1, shown with a steering wheel shown in dotted lines;  
FIG. 9 is a front, right perspective view of the dashboard for a watercraft of FIG. 1; and,  
FIG. 10 is front, top, right perspective view of the dashboard for a watercraft of FIG. 1, shown on a watercraft shown in dotted lines.

Throughout the Figures, where shown: (i) the dotted lines showing additional structure of the dashboard for a watercraft are for illustrative purposes only and form no part of the claimed design; (ii) the unshaded surfaces do not form part of the claimed design; and (iii) the dotted/dashed lines illustrate unclaimed boundaries of surfaces claimed as part of the design. Portions of the dashboard for a watercraft not shown in the Figures and not otherwise described in this Specification do not form part of the claimed design. The inventors anticipate that the invention can be any part, portion, element or combination of elements of the dashboard for a watercraft shown in the Figures.

**1 Claim, 10 Drawing Sheets**

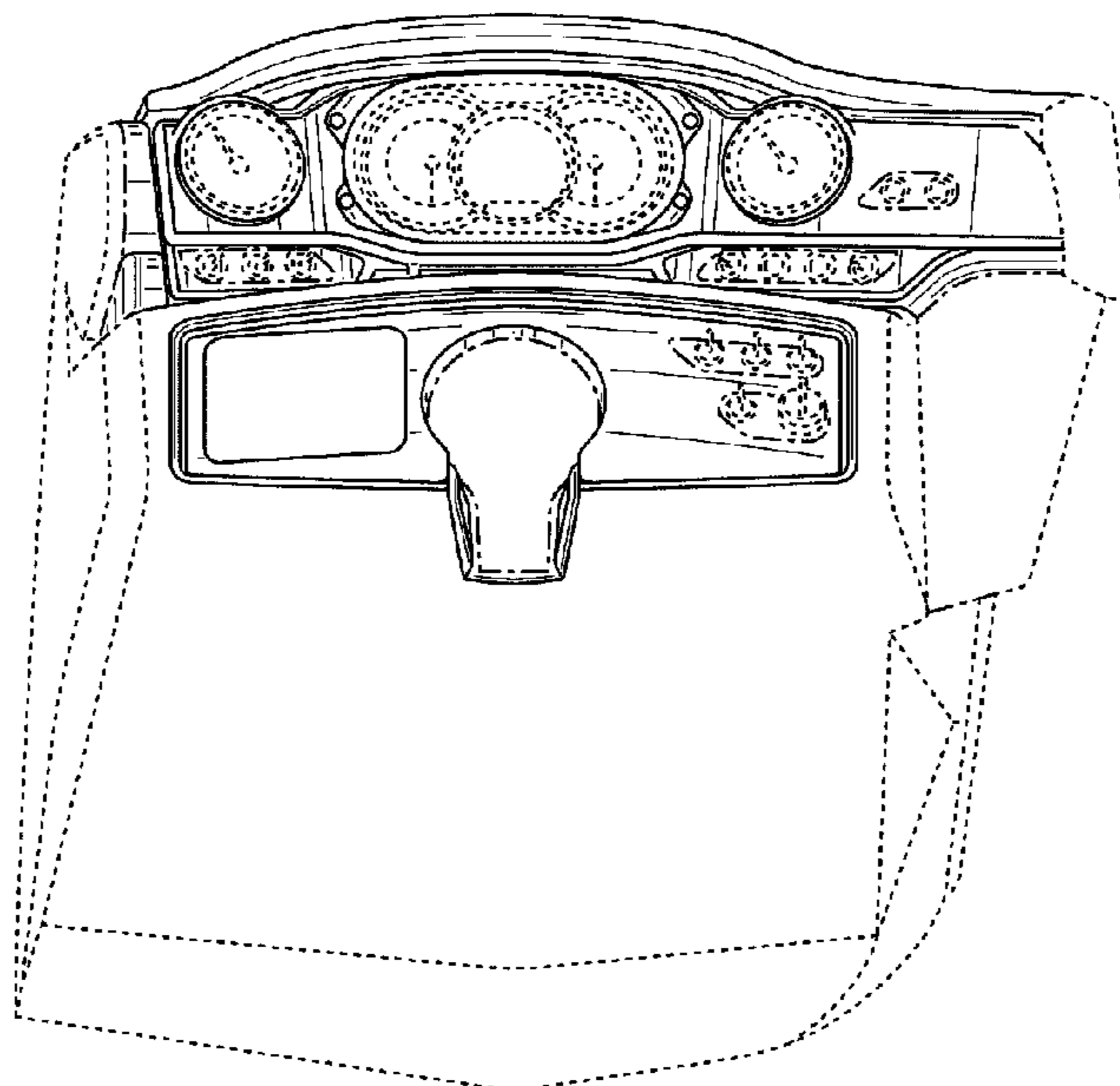

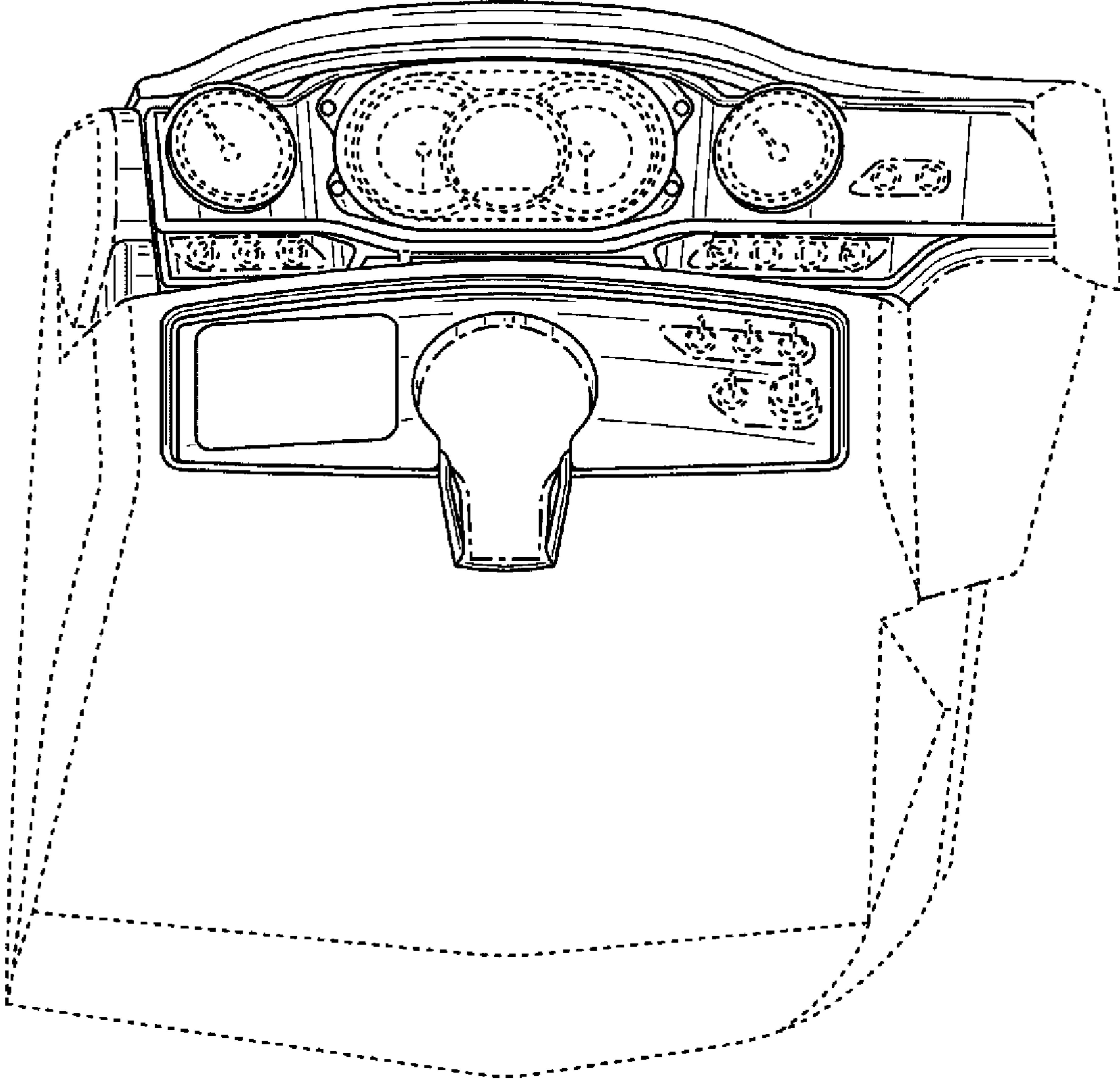

FIG. 1

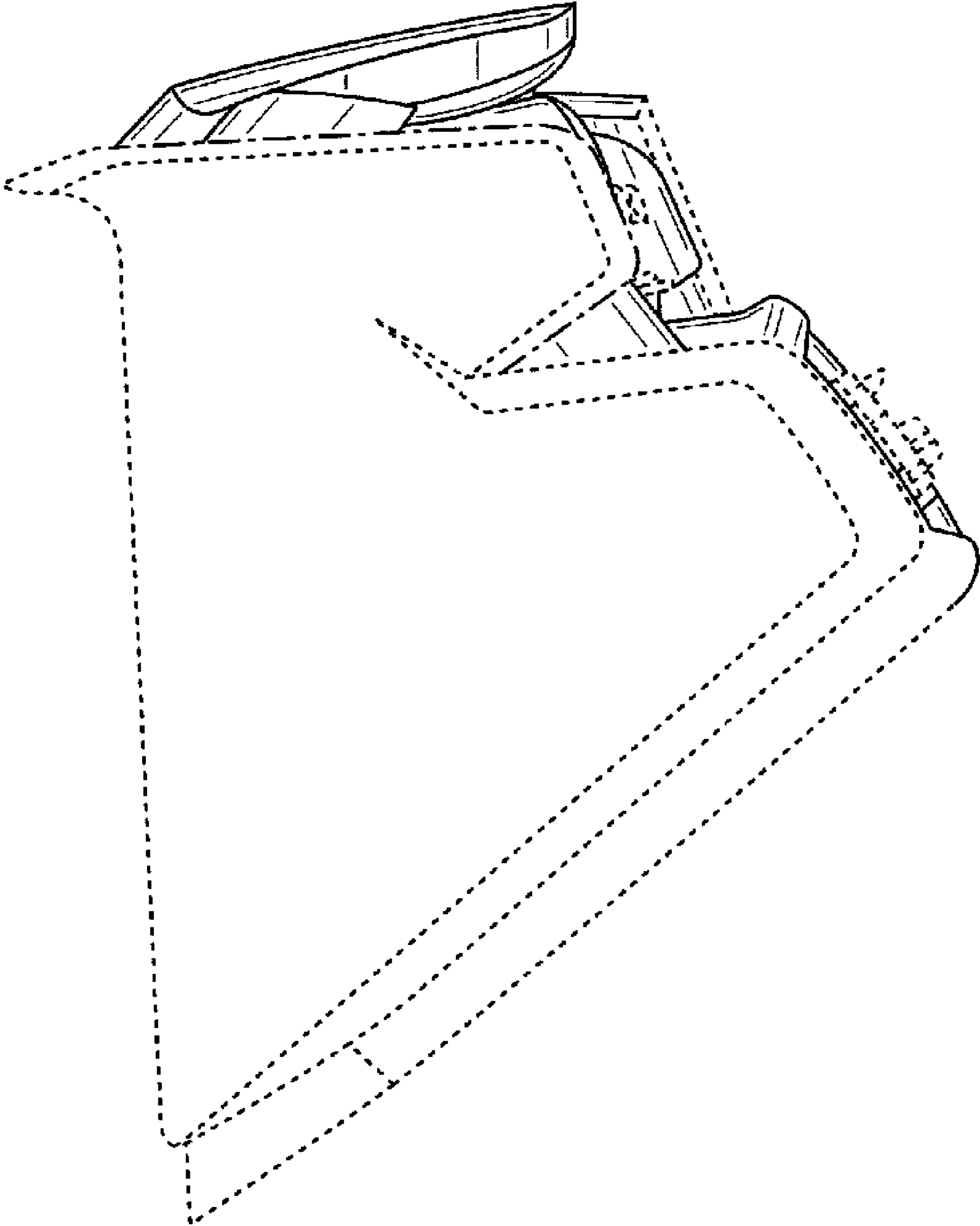

FIG. 2

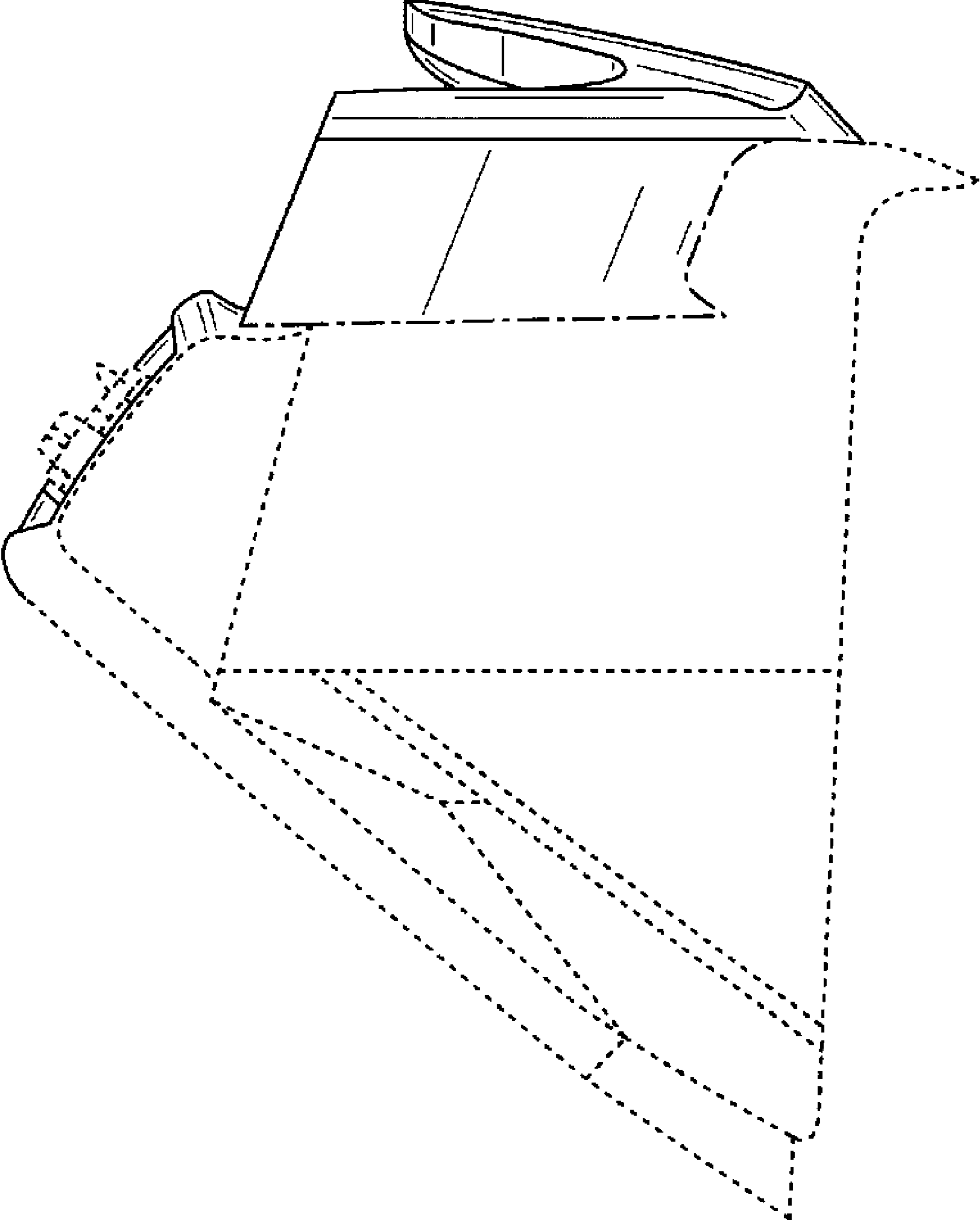

FIG. 3

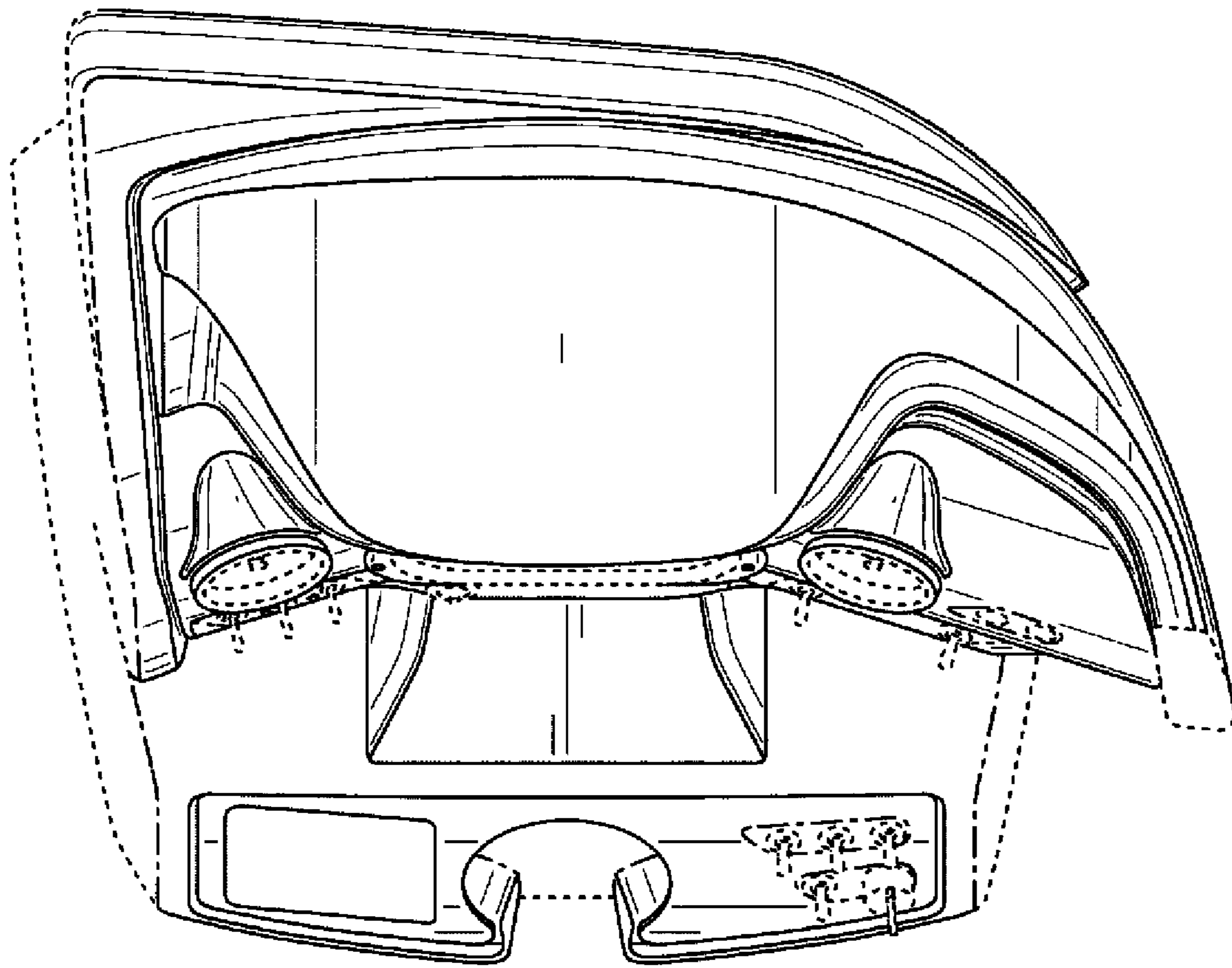

FIG. 4



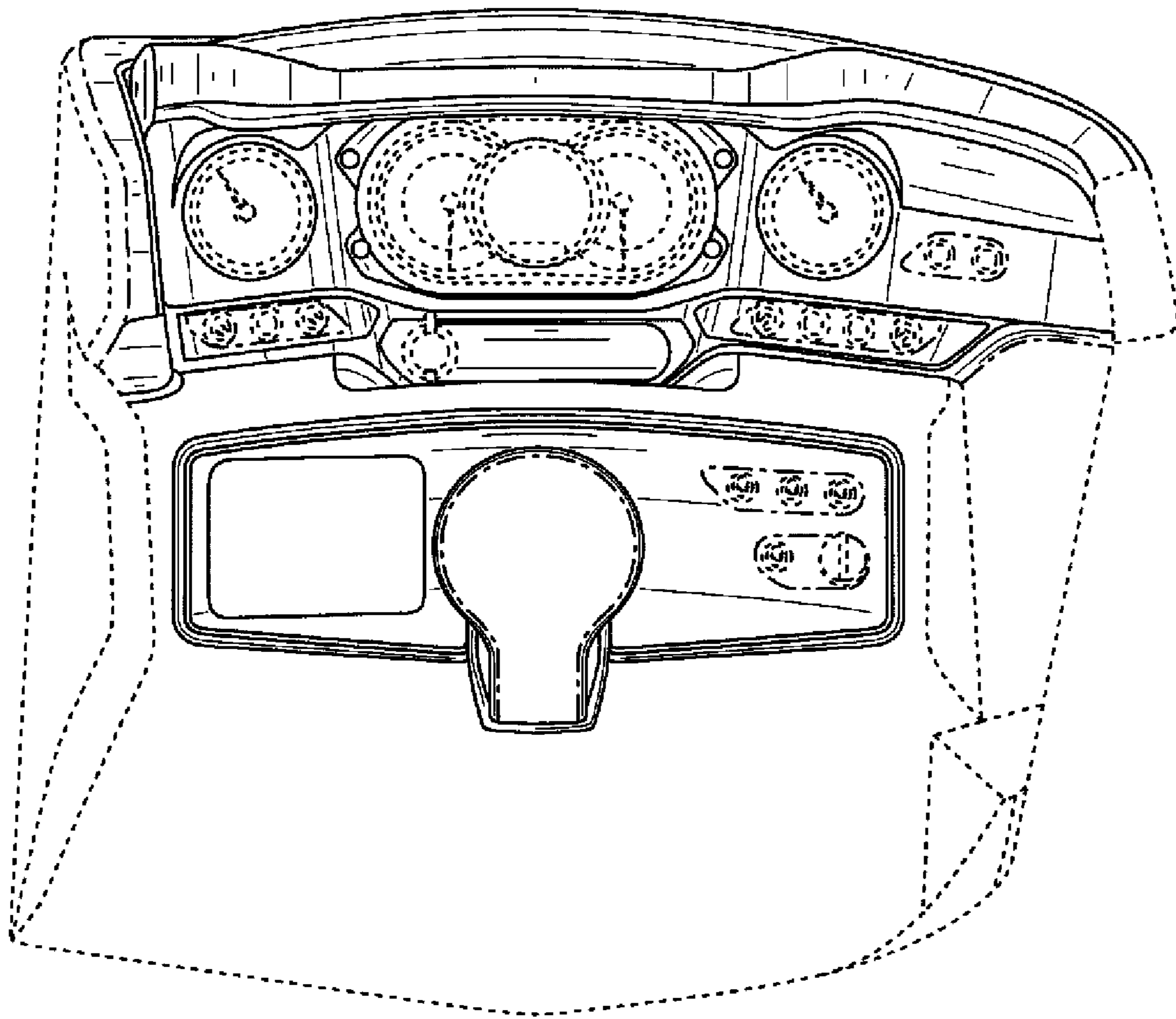

FIG. 5

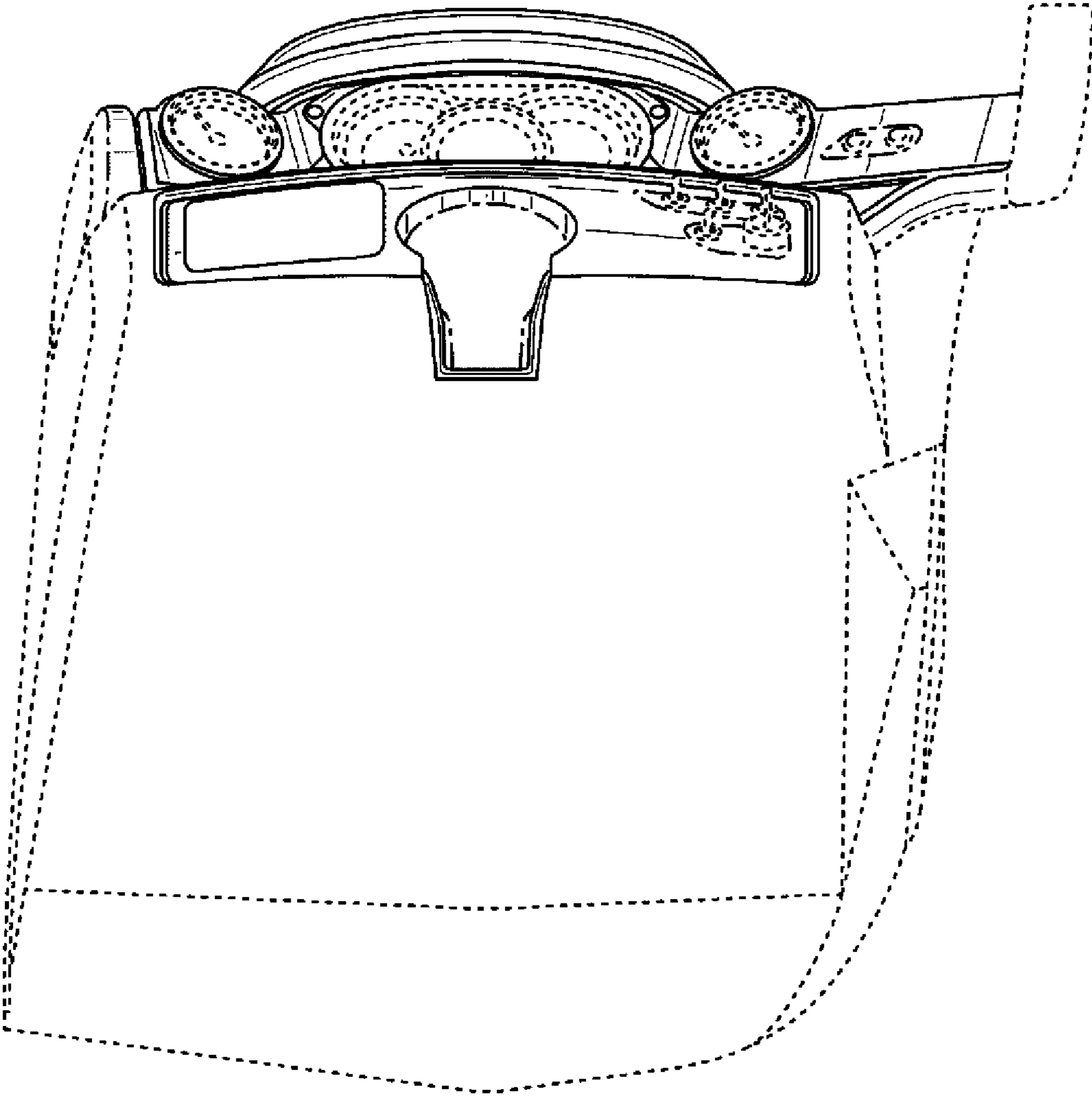

FIG. 6

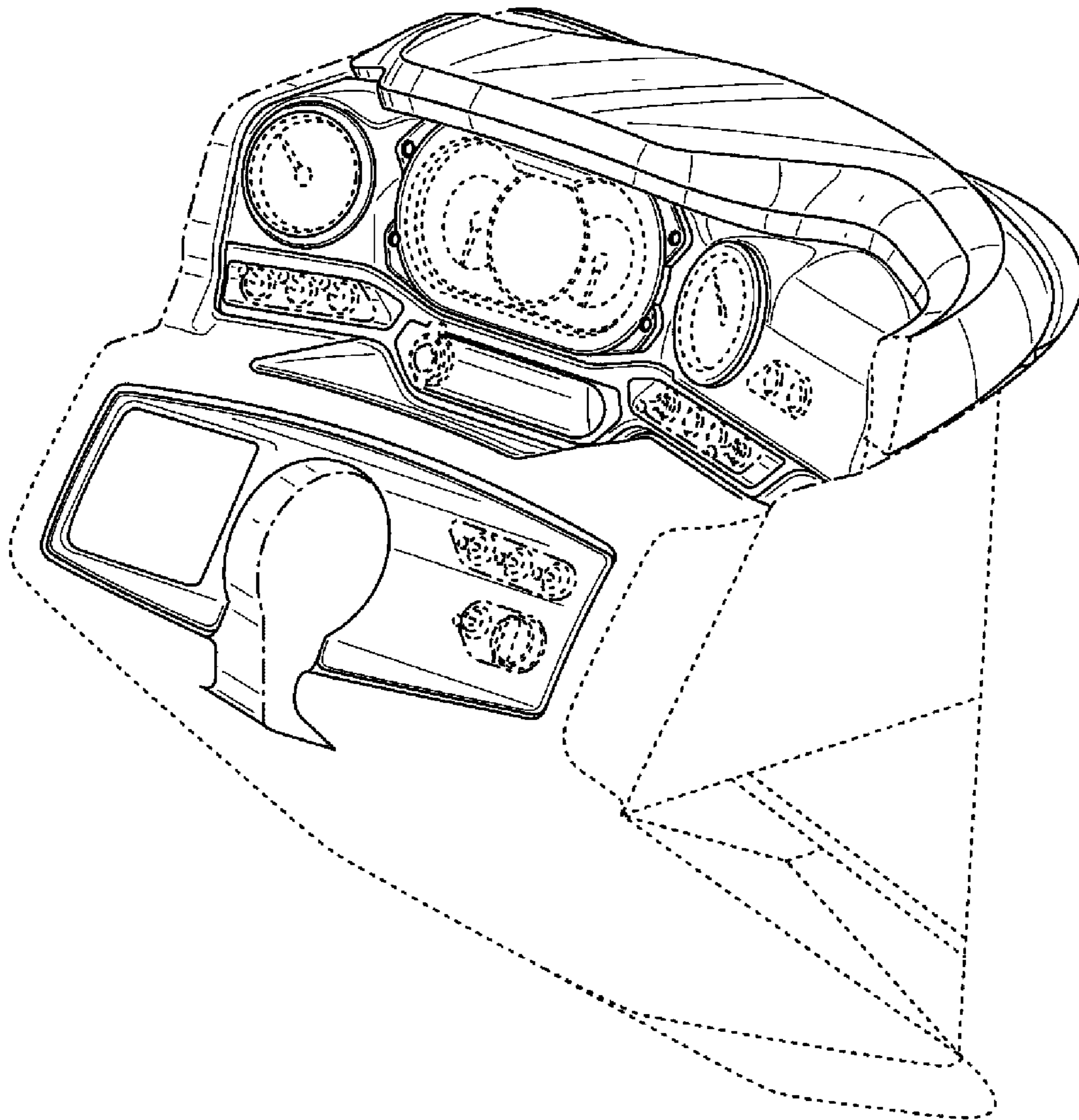

FIG. 7



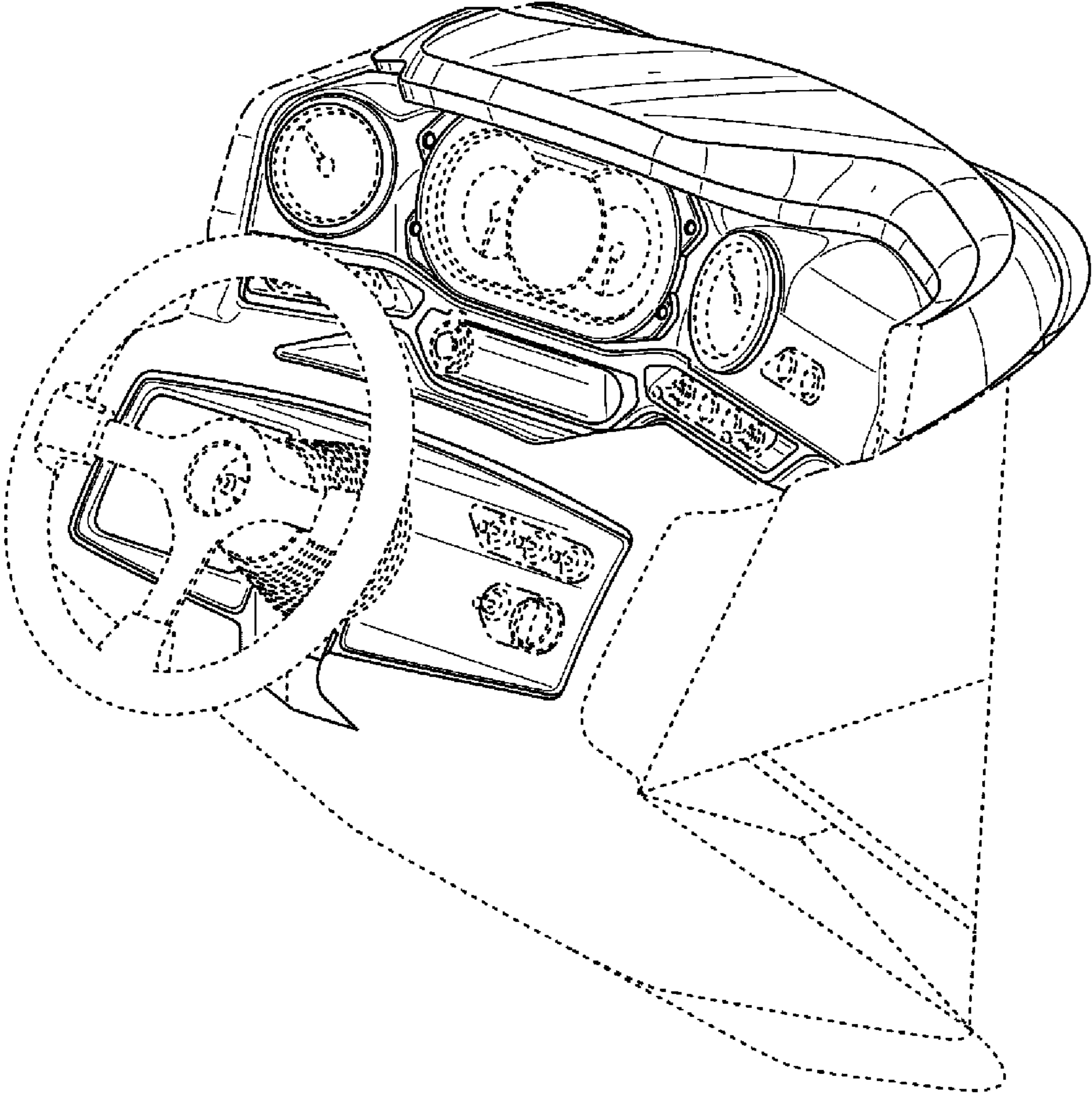

FIG. 8

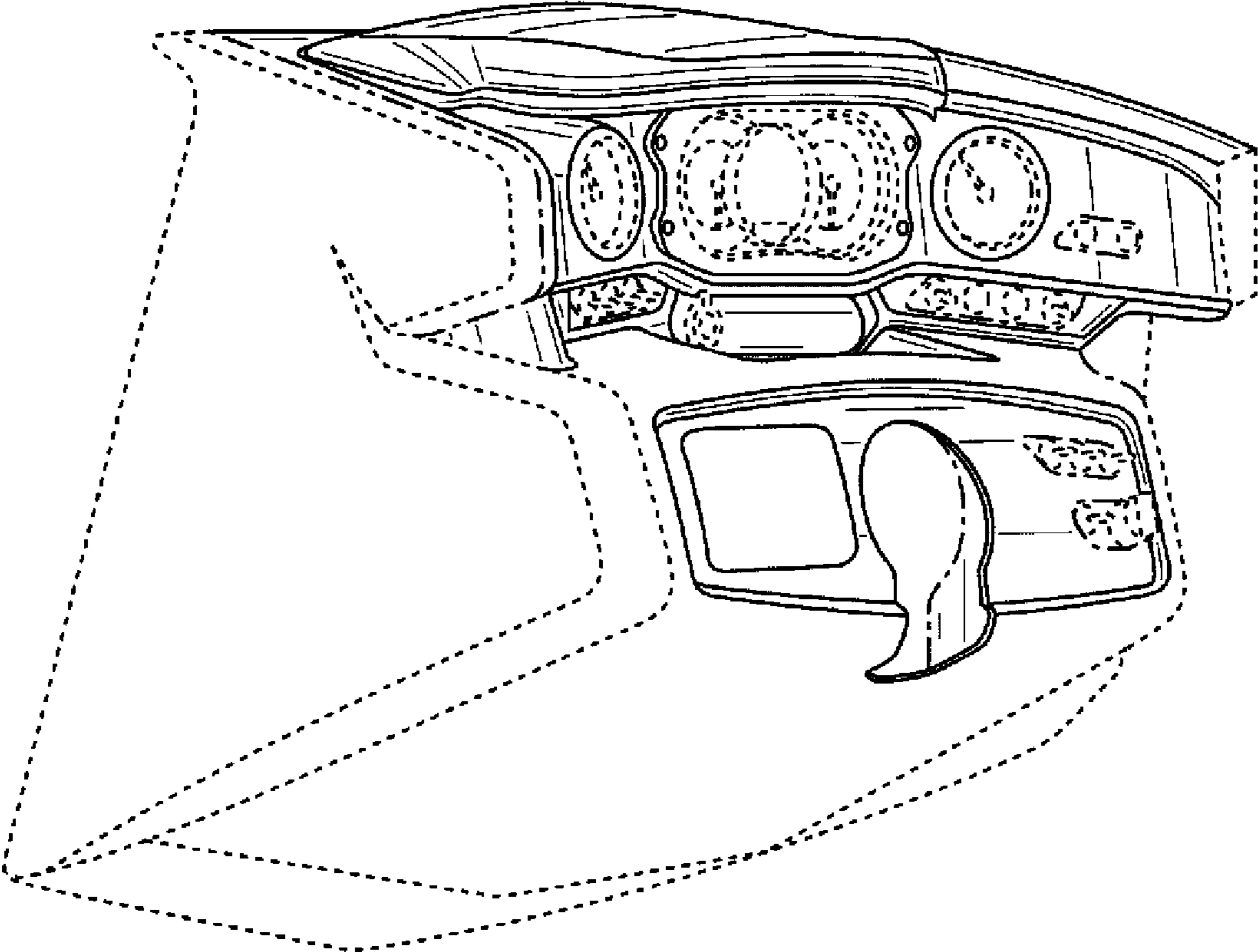

FIG. 9

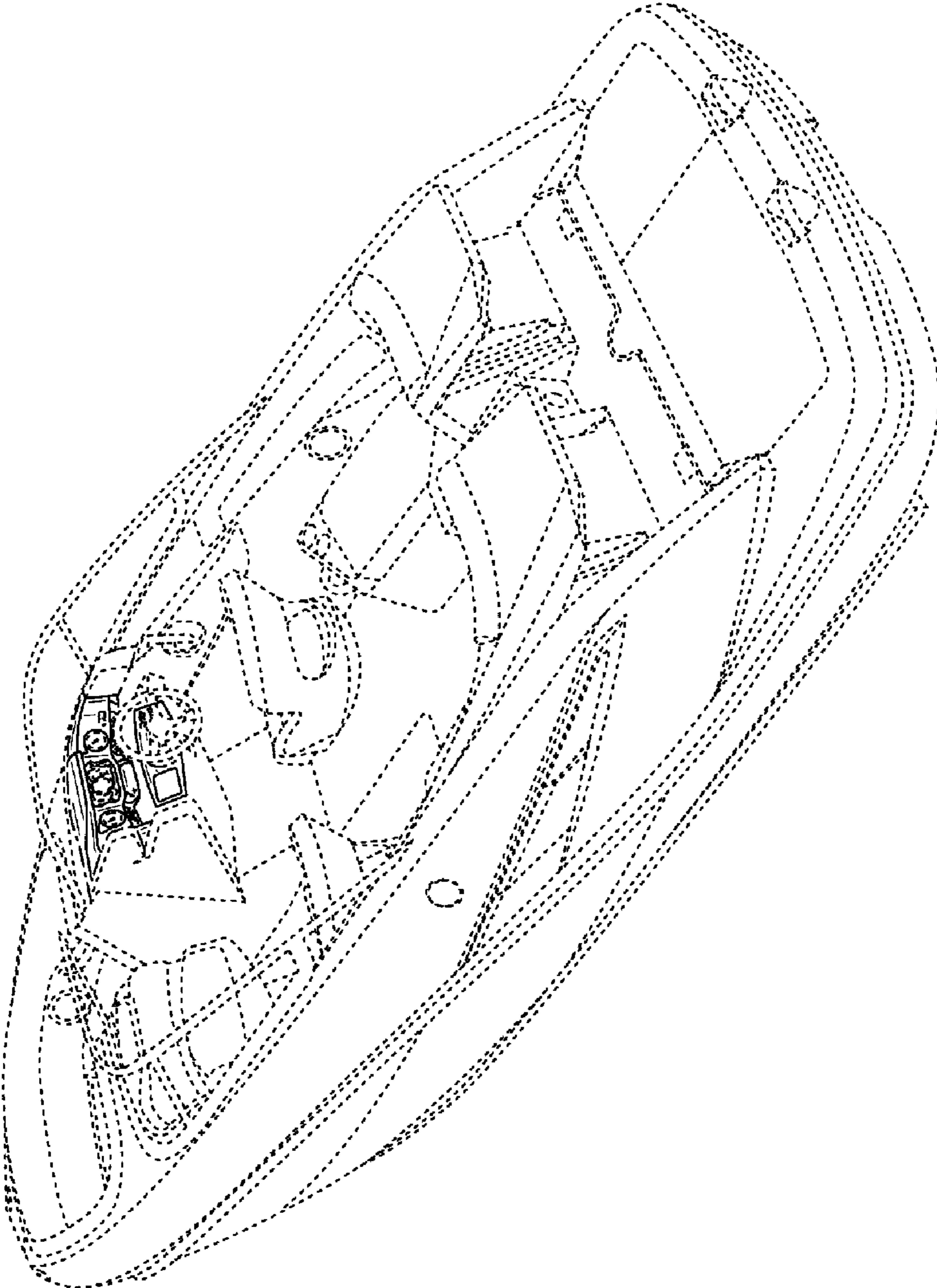

FIG. 10

UNITED STATES PATENT AND TRADEMARK OFFICE  
**CERTIFICATE OF CORRECTION**

PATENT NO. : D650,728 S  
APPLICATION NO. : 29/352657  
DATED : December 20, 2011  
INVENTOR(S) : Jacques Mayrand, Luc Quirin and Alexandre Curthelet

Page 1 of 1

It is certified that error appears in the above-identified patent and that said Letters Patent is hereby corrected as shown below:

Title Page, in the Description, the phrase:

“The inventors anticipate that the invention can be any part, portion, element or combination of elements of the dashboard for a watercraft shown in the Figures.”

should be deleted.

Signed and Sealed this  
Twentieth Day of March, 2012



David J. Kappos  
*Director of the United States Patent and Trademark Office*