



US00D650715S

(12) **United States Design Patent**  
**Hill et al.**

(10) **Patent No.:** **US D650,715 S**

(45) **Date of Patent:** **\*\* Dec. 20, 2011**

(54) **CHILD ALERT TRANSMITTER AND KEY  
FOB RECEIVER SET FOR A CAR SEAT**

(76) Inventors: **Brian T. Hill**, Dallas, GA (US);  
**Courtney R. Hill**, Dallas, GA (US);  
**Anthony Jackson, Sr.**, Dallas, GA (US);  
**Gwendolyn Offner-Jackson**, Dallas,  
GA (US)

(\*\*) Term: **14 Years**

(21) Appl. No.: **29/369,842**

(22) Filed: **Sep. 14, 2010**

(51) **LOC (9) Cl.** ..... **10-05**

(52) **U.S. Cl.** ..... **D10/104.2**

(58) **Field of Classification Search** ..... D10/104.1,  
D10/104.2; D3/207; D14/218, 138; D13/207;  
340/457, 573.4; 362/157, 116, 200  
See application file for complete search history.

(56) **References Cited**

U.S. PATENT DOCUMENTS

D376,114	S	*	12/1996	Seki et al.	.....	D10/104.1
D380,695	S	*	7/1997	Seki et al.	.....	D10/104.1
D441,185	S	*	5/2001	Shimizu et al.	.....	D3/207
D441,524	S	*	5/2001	Shimizu et al.	.....	D3/207
D496,638	S	*	9/2004	Deubler, Jr.	.....	D14/138 R
6,812,844	B1		11/2004	Burgess		

6,909,365	B2		6/2005	Toles		
7,106,203	B2		9/2006	Edwards et al.		
D604,039	S	*	11/2009	Fleming	.....	D3/207
2003/0122662	A1	*	7/2003	Quinonez	.....	340/457
2006/0208911	A1	*	9/2006	Davis	.....	340/573.4
2007/0075575	A1		4/2007	Gregory, II et al.		

\* cited by examiner

*Primary Examiner* — George D Kirschabum

(74) *Attorney, Agent, or Firm* — Crossley Patent Law; Mark  
A. Crossley

(57) **CLAIM**

The ornamental design for a child alert transmitter and key  
fob receiver set for a car seat, as shown and described.

**DESCRIPTION**

FIG. 1 is a front elevation view of a child alert transmitter and  
key fob receiver set for a car seat showing our new design;  
FIG. 2 is a rear elevation view thereof;  
FIG. 3 is a right elevation view thereof;  
FIG. 4 is a left elevation view thereof;  
FIG. 5 is a top plan view thereof;  
FIG. 6 is a bottom plan view thereof; and,  
FIG. 7 is an isometric view thereof.

The broken lines in the drawings depict environmental sub-  
ject matter only and form no part of the claimed design.

**1 Claim, 5 Drawing Sheets**

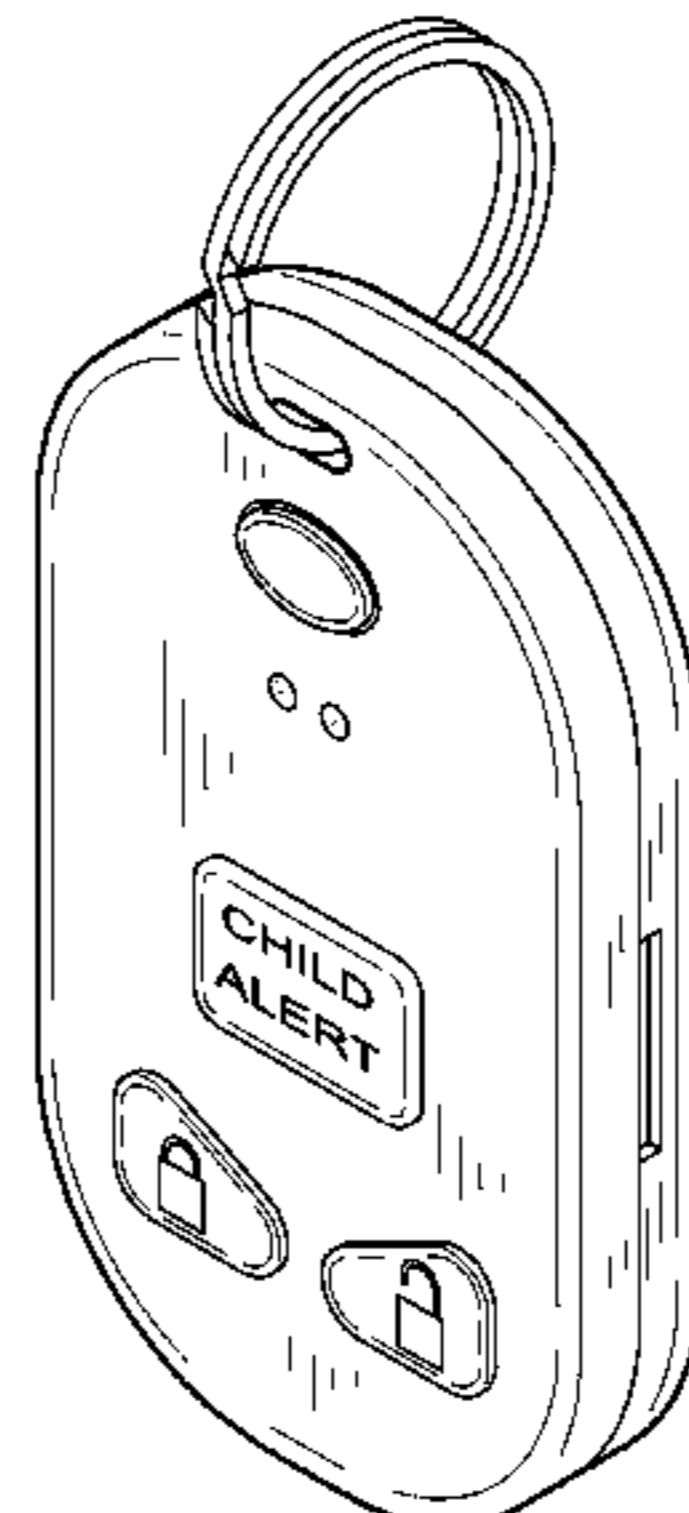
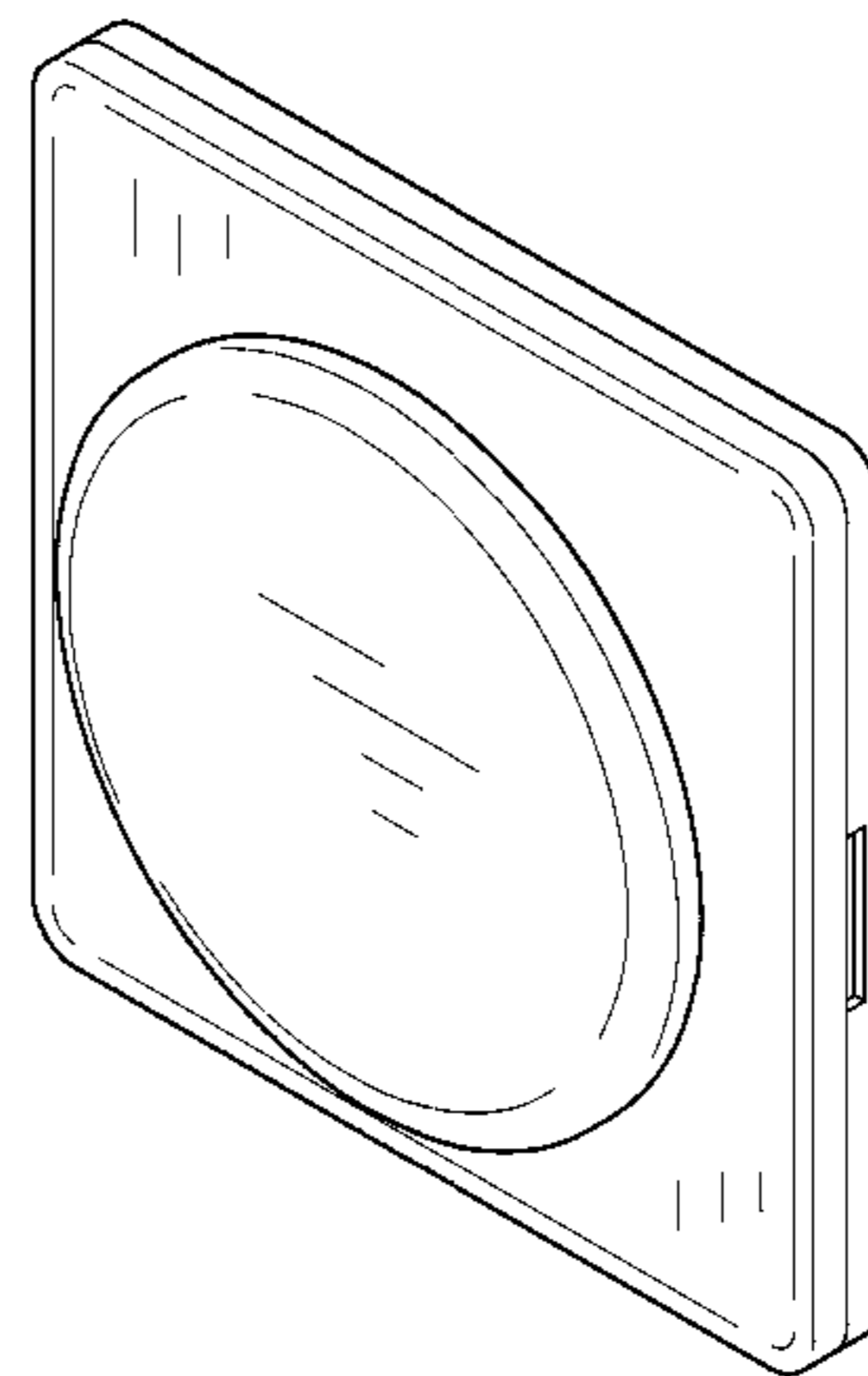
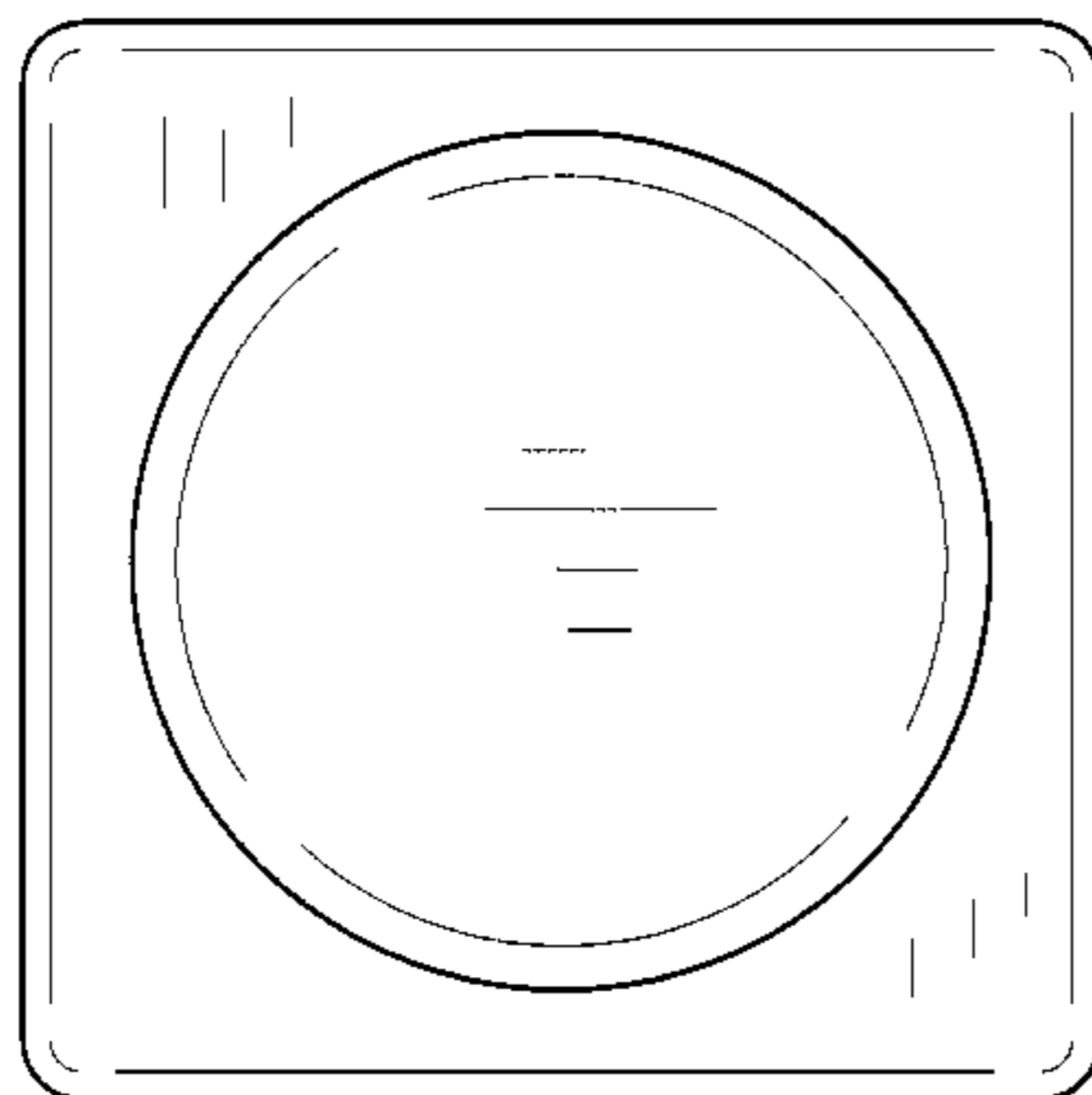

FIG. 1

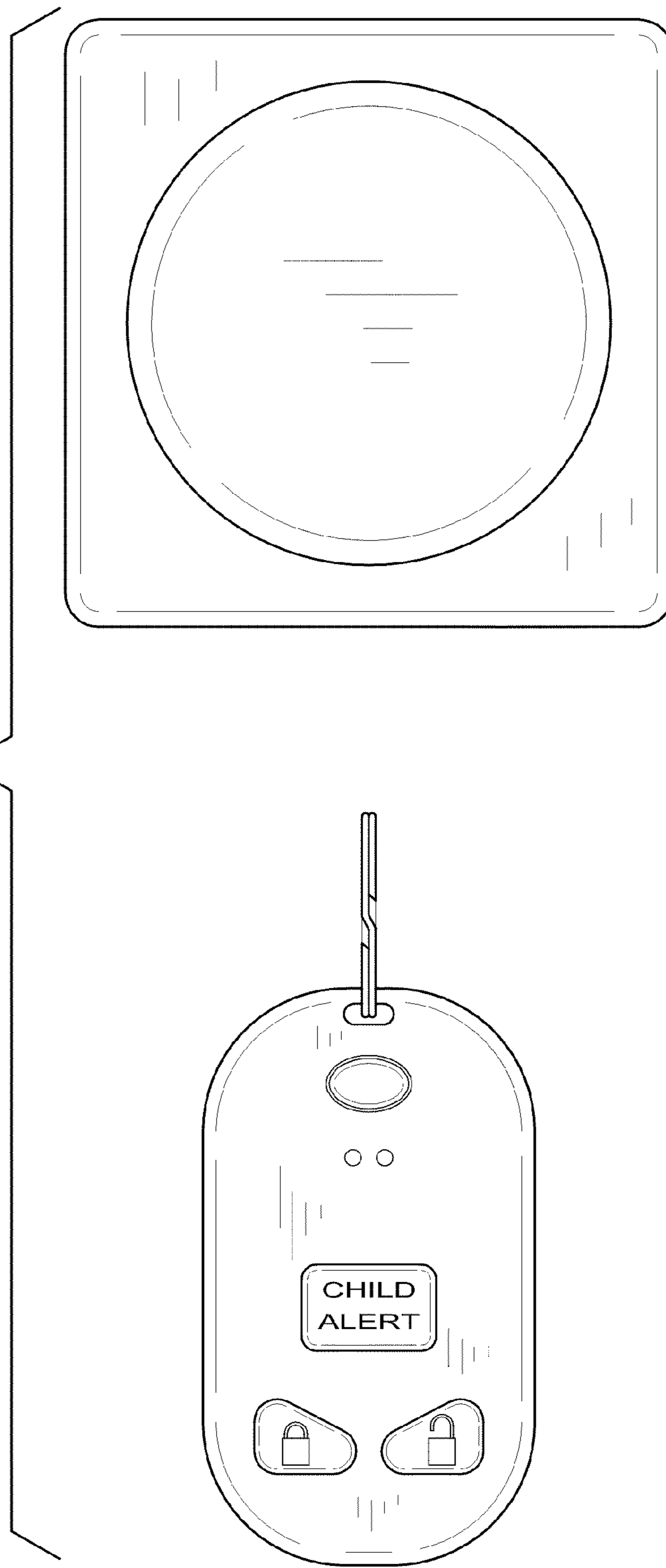
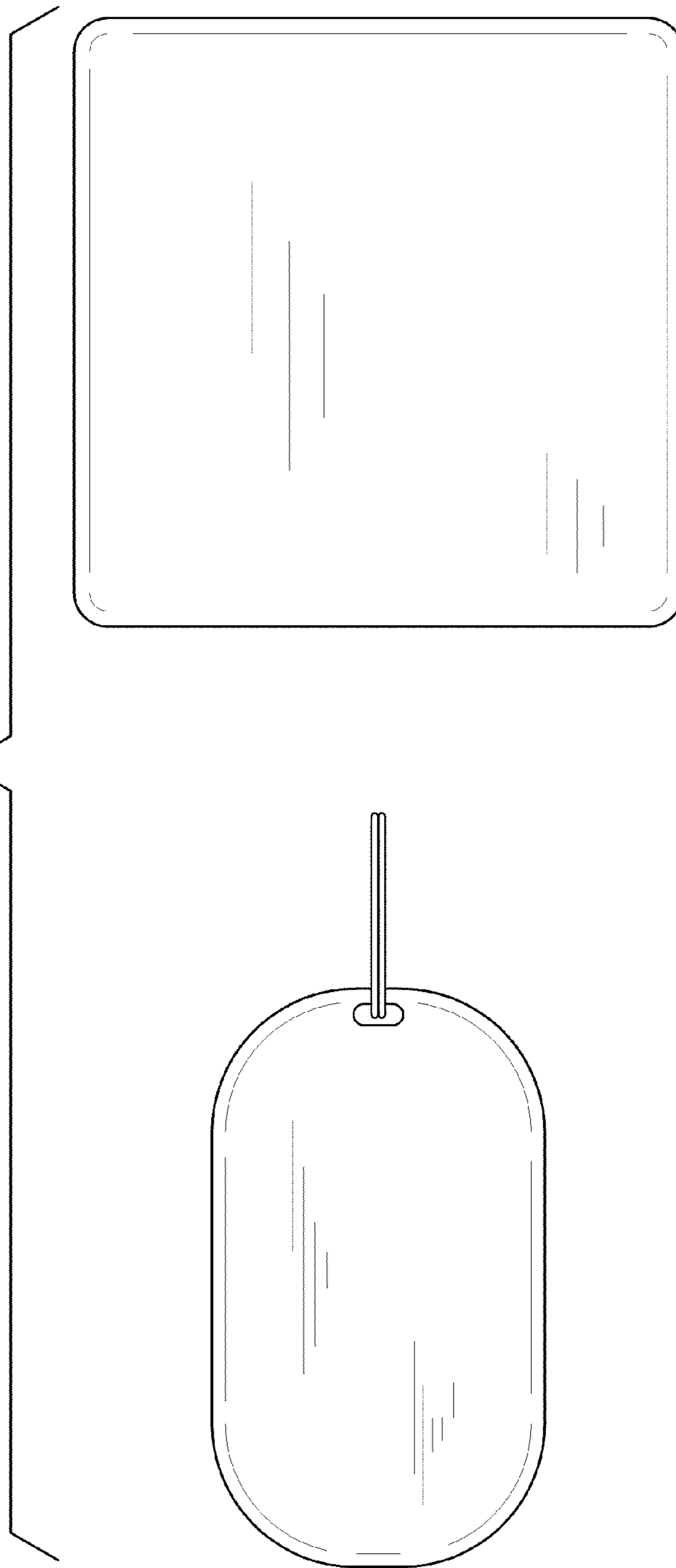

FIG. 2



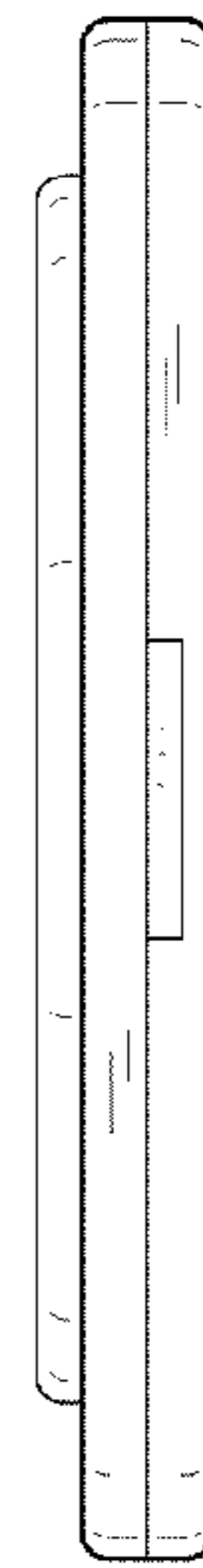

FIG. 3

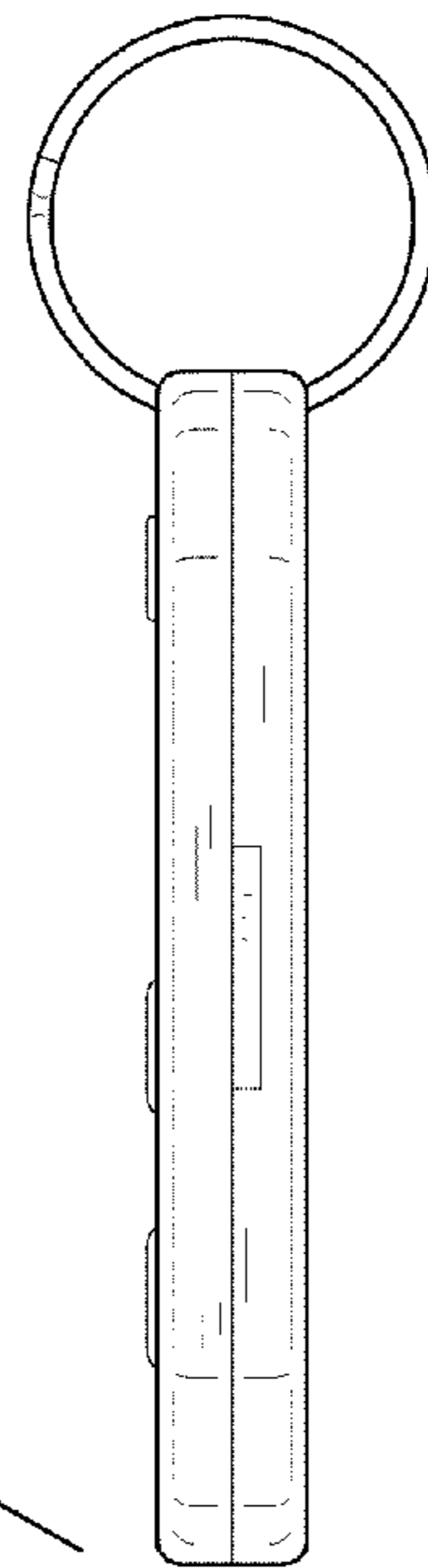
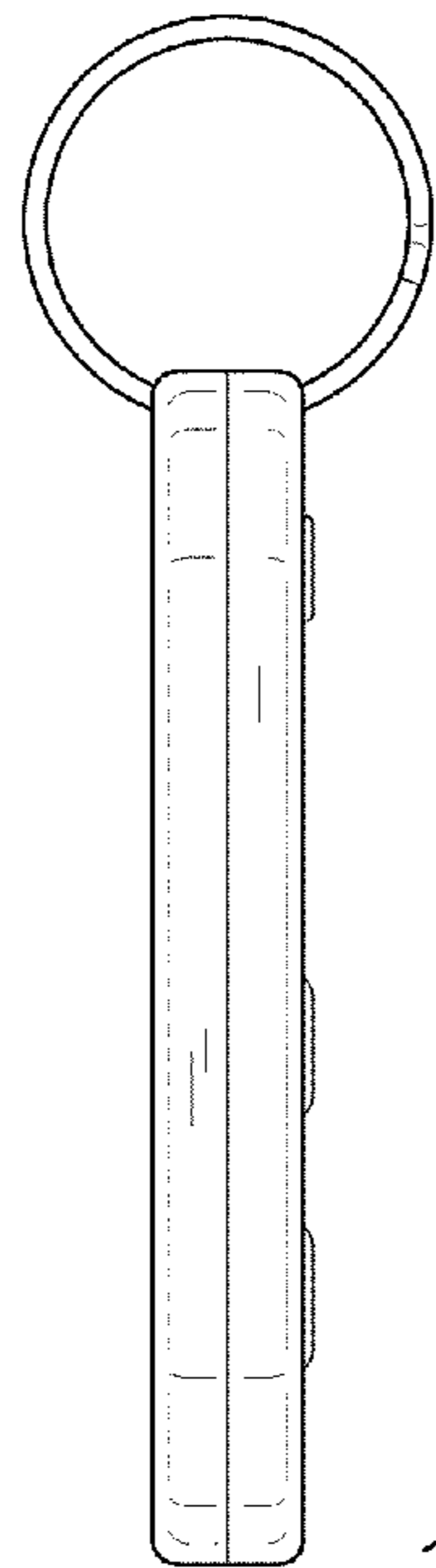

FIG. 4

FIG. 5

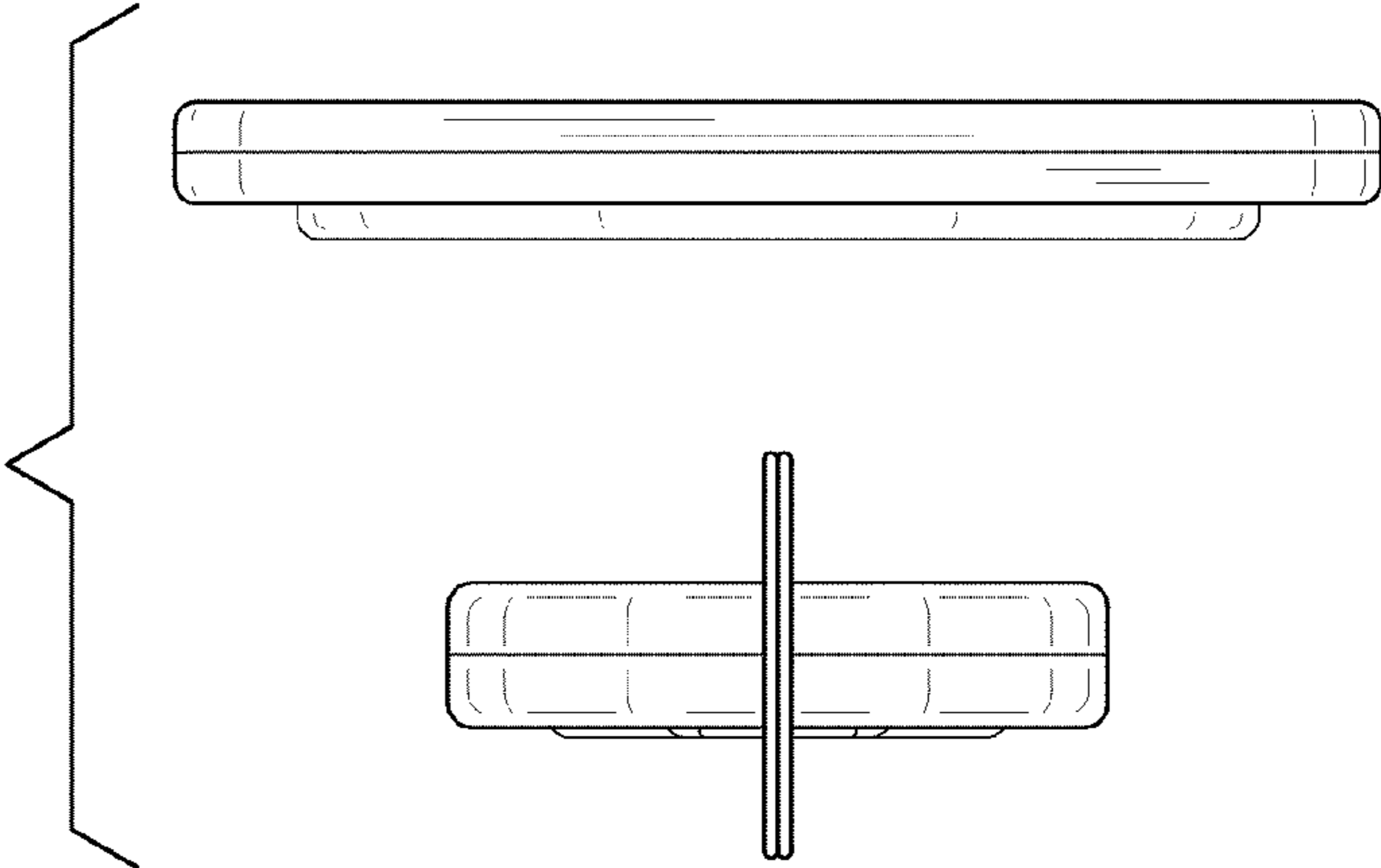

FIG. 6

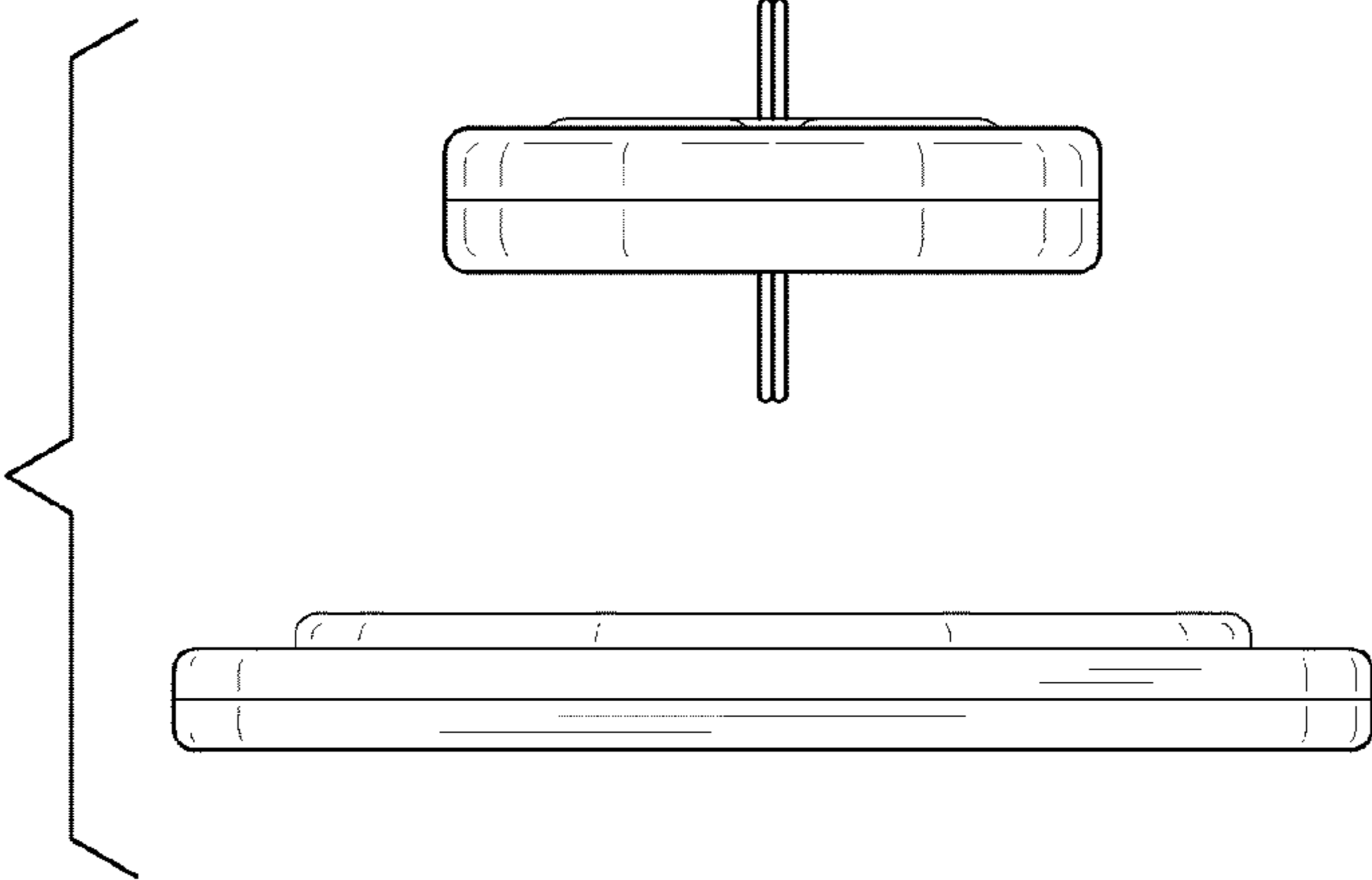

FIG. 7

