



US00D650651S

(12) **United States Design Patent**
Misaki

(10) **Patent No.:** **US D650,651 S**

(45) **Date of Patent:** **** Dec. 20, 2011**

(54) **PORTABLE ELECTRIC SANDER**

(75) Inventor: **Shingo Misaki, Anjo (JP)**

(73) Assignee: **Makita Corporation, Anjo-shi (JP)**

(**) Term: **14 Years**

(21) Appl. No.: **29/375,976**

(22) Filed: **Sep. 30, 2010**

(30) **Foreign Application Priority Data**

Apr. 7, 2010 (JP) 2010-008708

(51) **LOC (9) Cl.** **08-01**

(52) **U.S. Cl.** **D8/62**

(58) **Field of Classification Search** D8/67,
D8/62, 61, 70; D32/15, 17, 19; D4/102;
451/456, 451, 359, 358, 357, 356, 355, 364,
451/344; 144/154.5, 373; 30/475

See application file for complete search history.

(56) **References Cited**

U.S. PATENT DOCUMENTS

D453,668	S	*	2/2002	Pretzell	D8/62
D487,008	S	*	2/2004	Andriolo	D8/62
D503,600	S	*	4/2005	Bian	D8/62
D526,549	S	*	8/2006	Aglassinger	D8/62
D527,235	S	*	8/2006	Aglassinger	D8/62
D538,122	S	*	3/2007	Etter et al.	D8/62
D548,556	S	*	8/2007	Stratford	D8/62
D551,526	S	*	9/2007	Aglassinger	D8/62
D555,449	S	*	11/2007	Waldron	D8/62
D567,047	S	*	4/2008	Okuda et al.	D8/62
D569,206	S	*	5/2008	Takahagi et al.	D8/61

D574,686	S	*	8/2008	Waldron	D8/62
D609,071	S	*	2/2010	Yamamoto et al.	D8/62
D628,454	S	*	12/2010	Misaki	D8/68
D628,455	S	*	12/2010	Misaki	D8/68
D628,869	S	*	12/2010	Misaki	D8/68
D632,939	S	*	2/2011	Misaki	D8/62
2002/0037691	A1	*	3/2002	Mayr et al.	451/356
2004/0002296	A1	*	1/2004	Reich et al.	451/357
2009/0298403	A1	*	12/2009	Yamashiro et al.	451/453
2010/0233944	A1	*	9/2010	Hagiwara	451/356

FOREIGN PATENT DOCUMENTS

JP S-D1384313 4/2010

OTHER PUBLICATIONS

Japanese Office Action dated Sep. 7, 2010 in Japanese Design Application No. 2010-008708 (with translation).

* cited by examiner

Primary Examiner — Austin Murphy

(74) *Attorney, Agent, or Firm* — Oliff & Berridge, PLC

(57) **CLAIM**

The ornamental design for a portable electric sander, as shown and described.

DESCRIPTION

FIG. 1 is a perspective view of a portable electric sander showing our new design;
FIG. 2 is a front elevation view thereof;
FIG. 3 is a rear elevation view thereof;
FIG. 4 is a left side elevation view thereof;
FIG. 5 is a right side elevation view thereof;
FIG. 6 is a top plan view thereof; and,
FIG. 7 is a bottom plan view thereof.

1 Claim, 6 Drawing Sheets

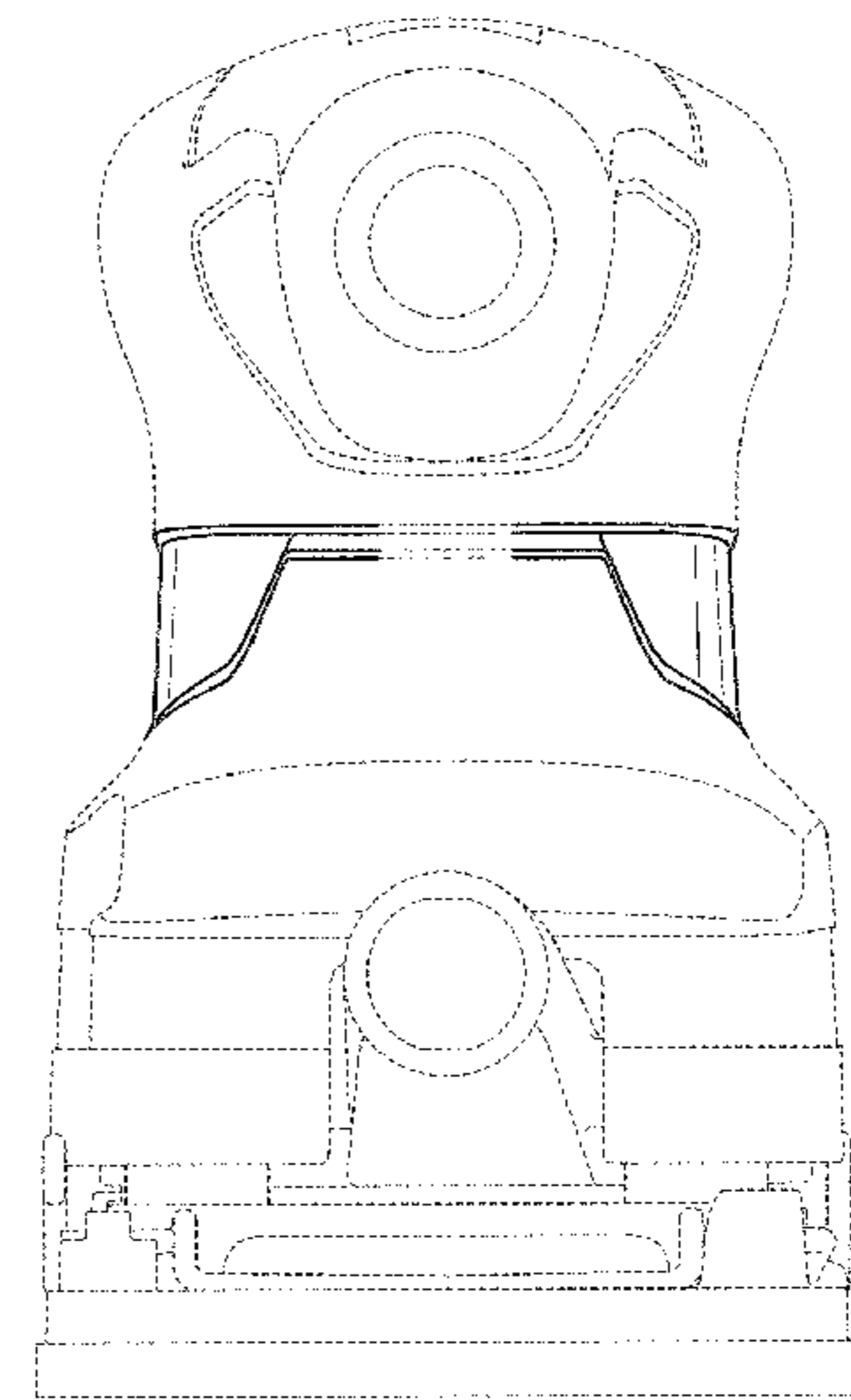
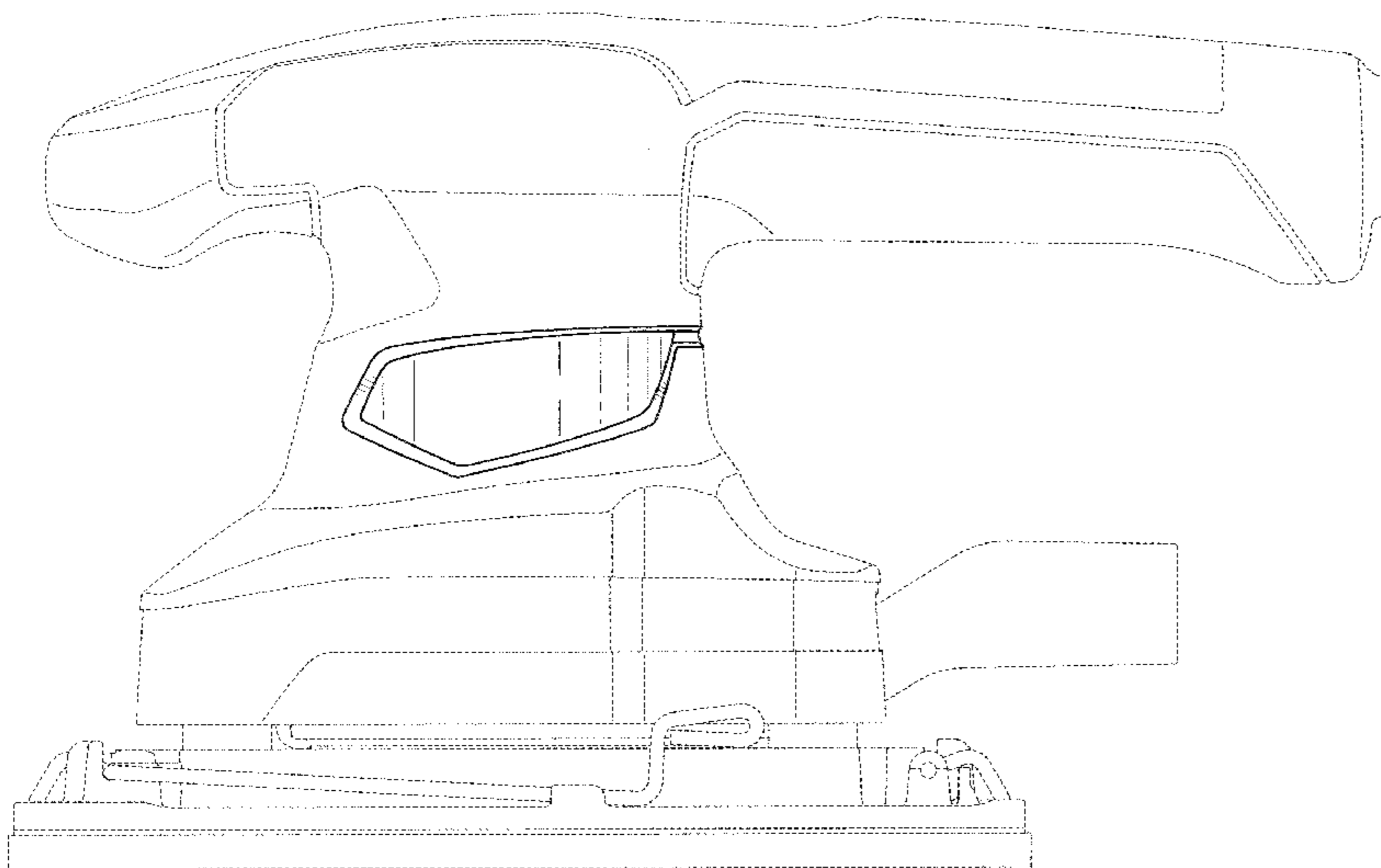

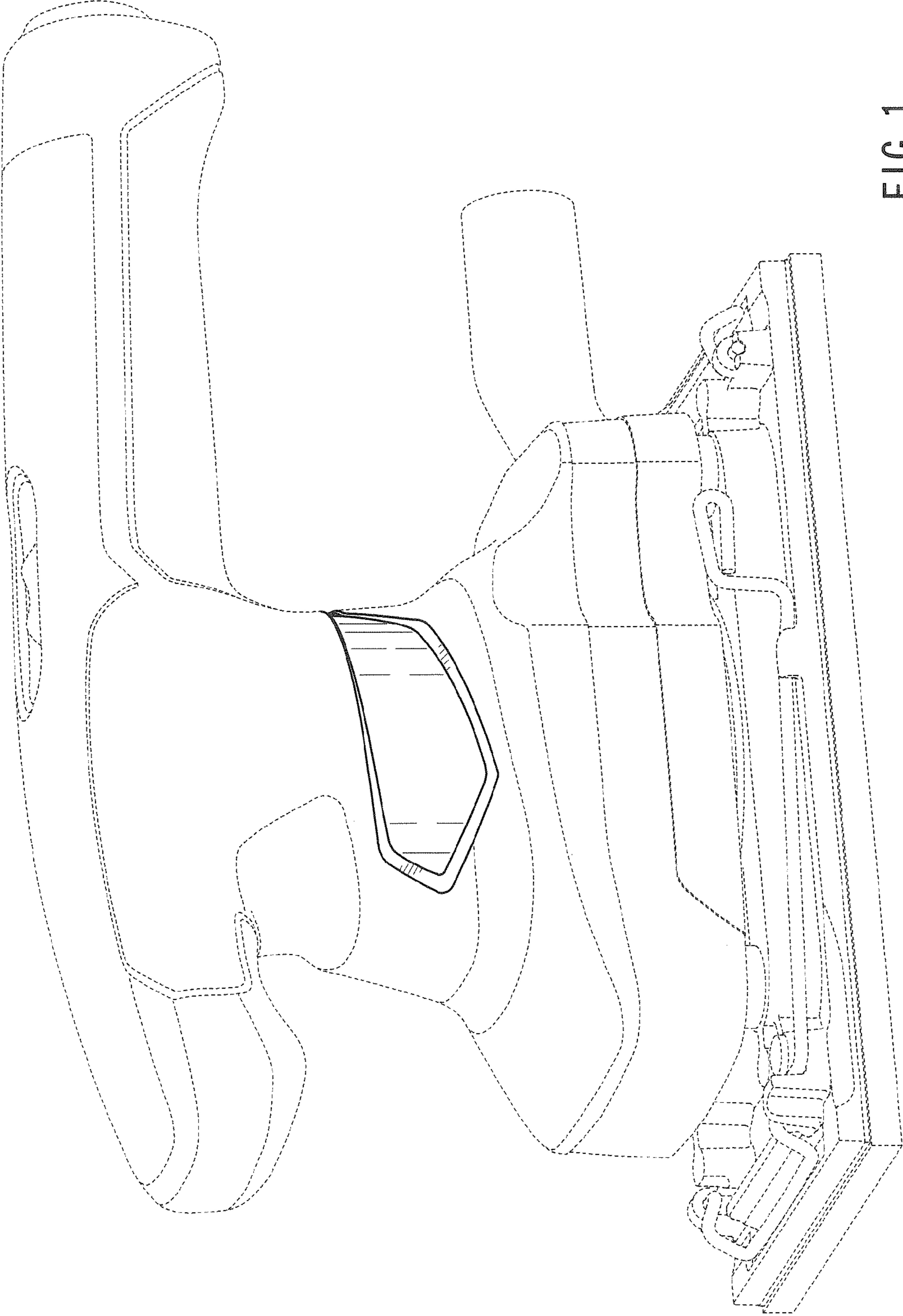

FIG. 1

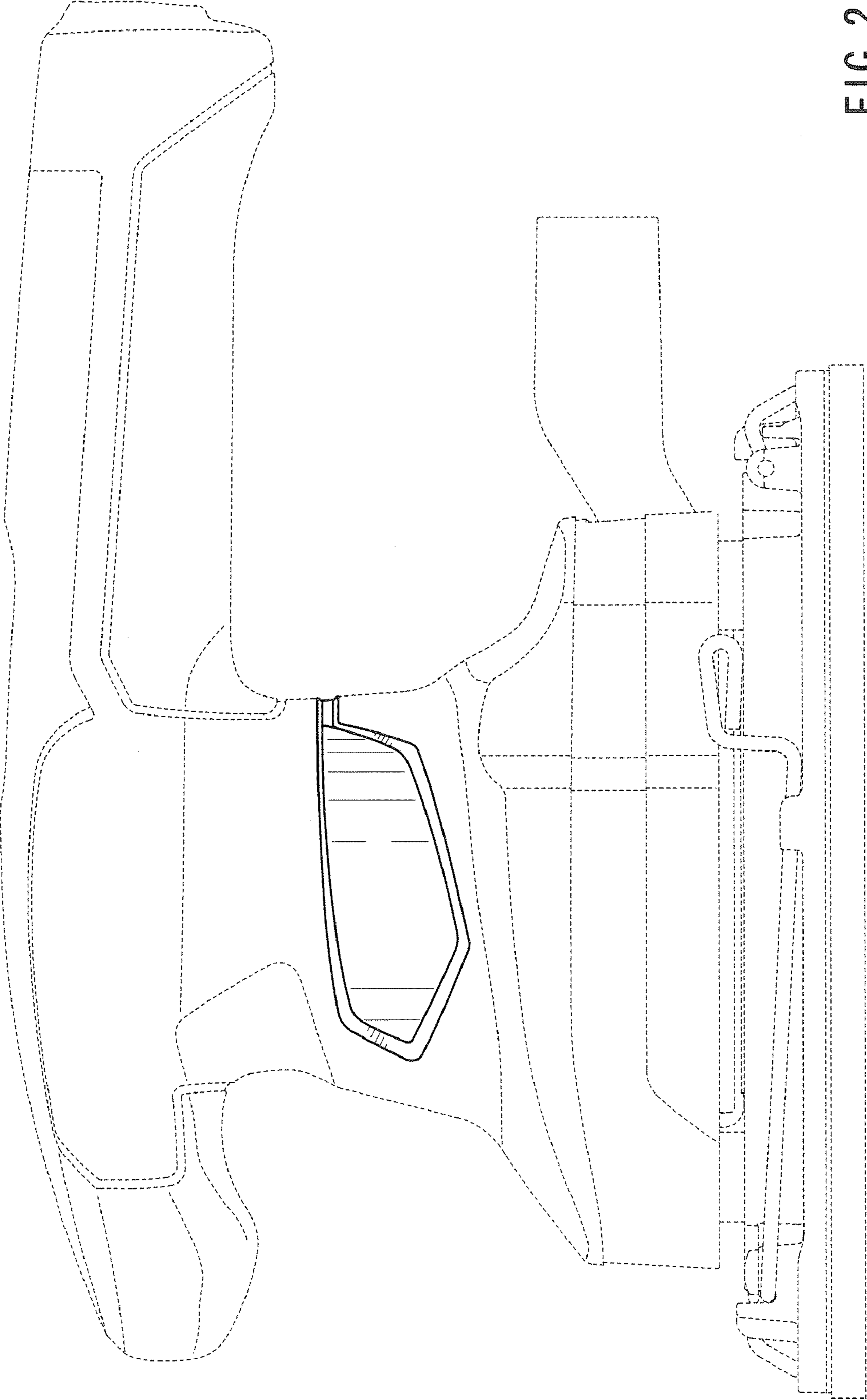

FIG. 2

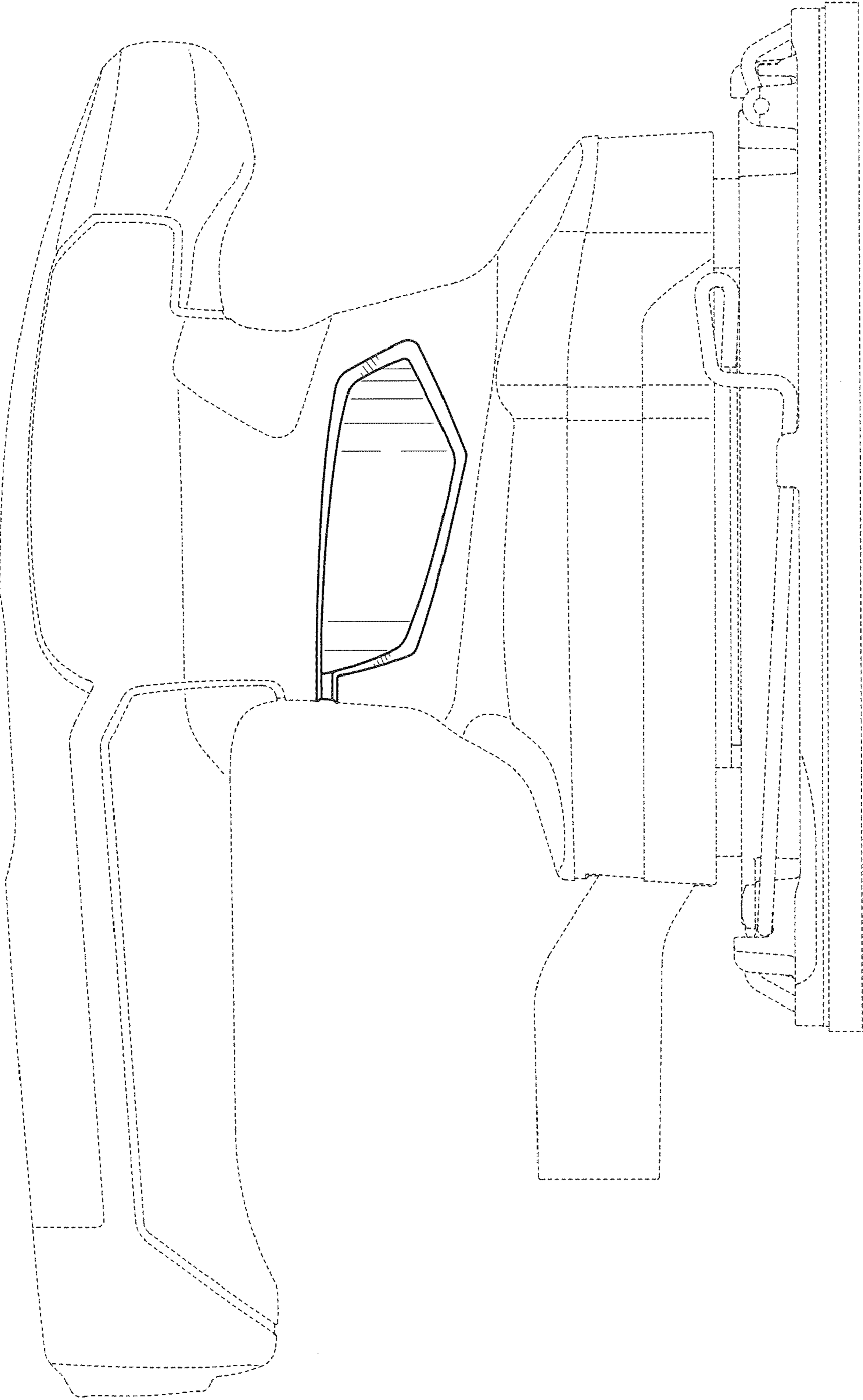

FIG. 3

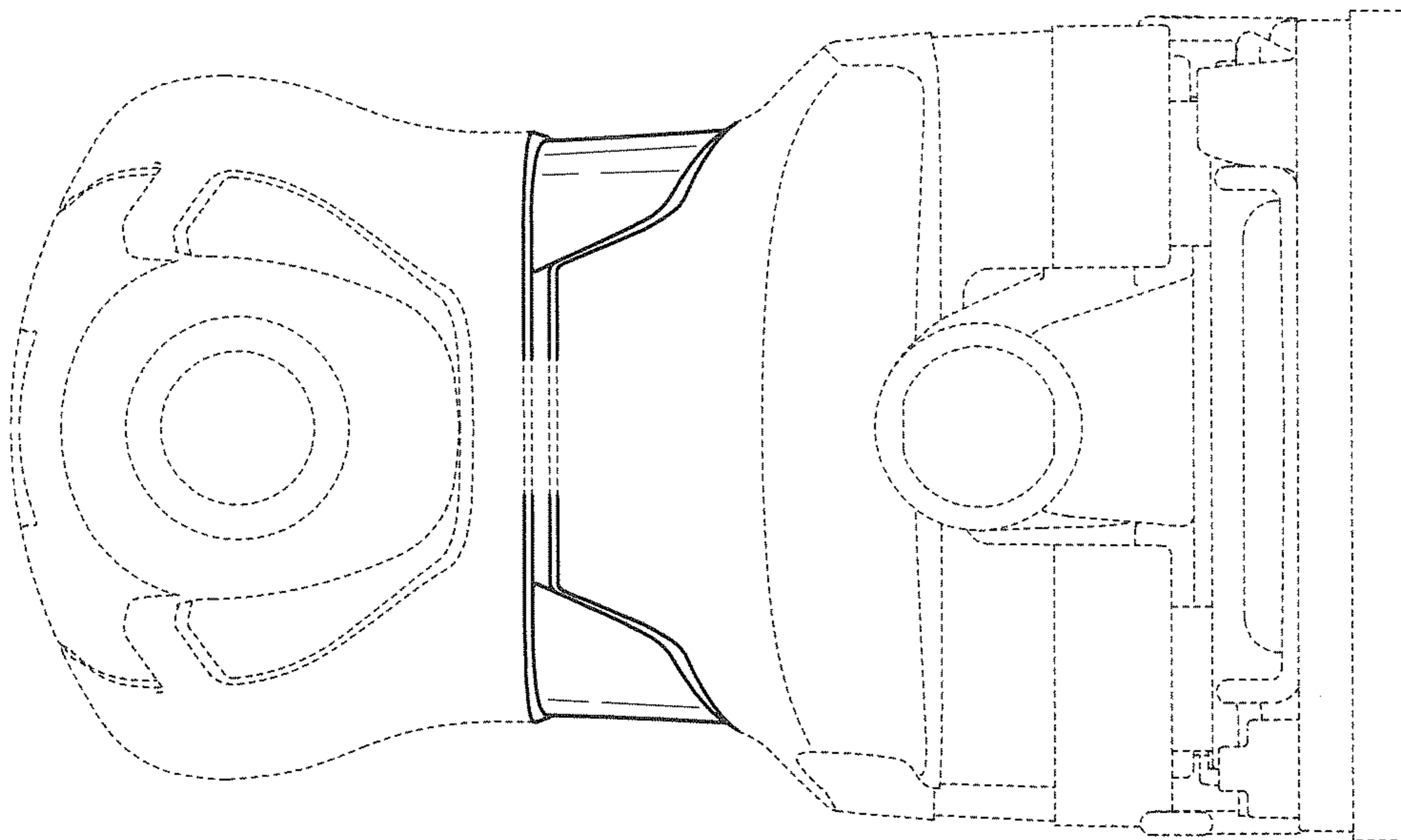

FIG. 4

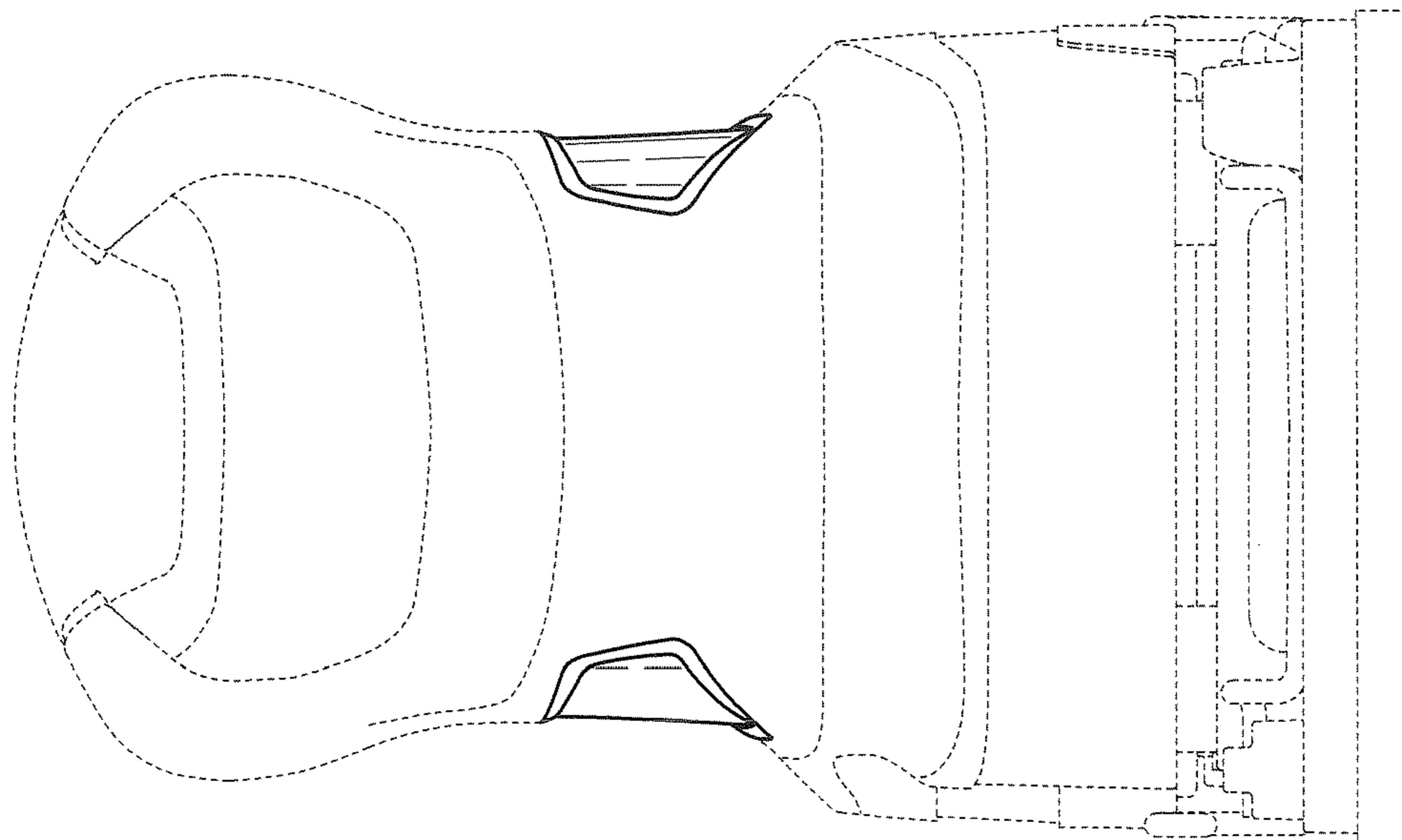

FIG. 5

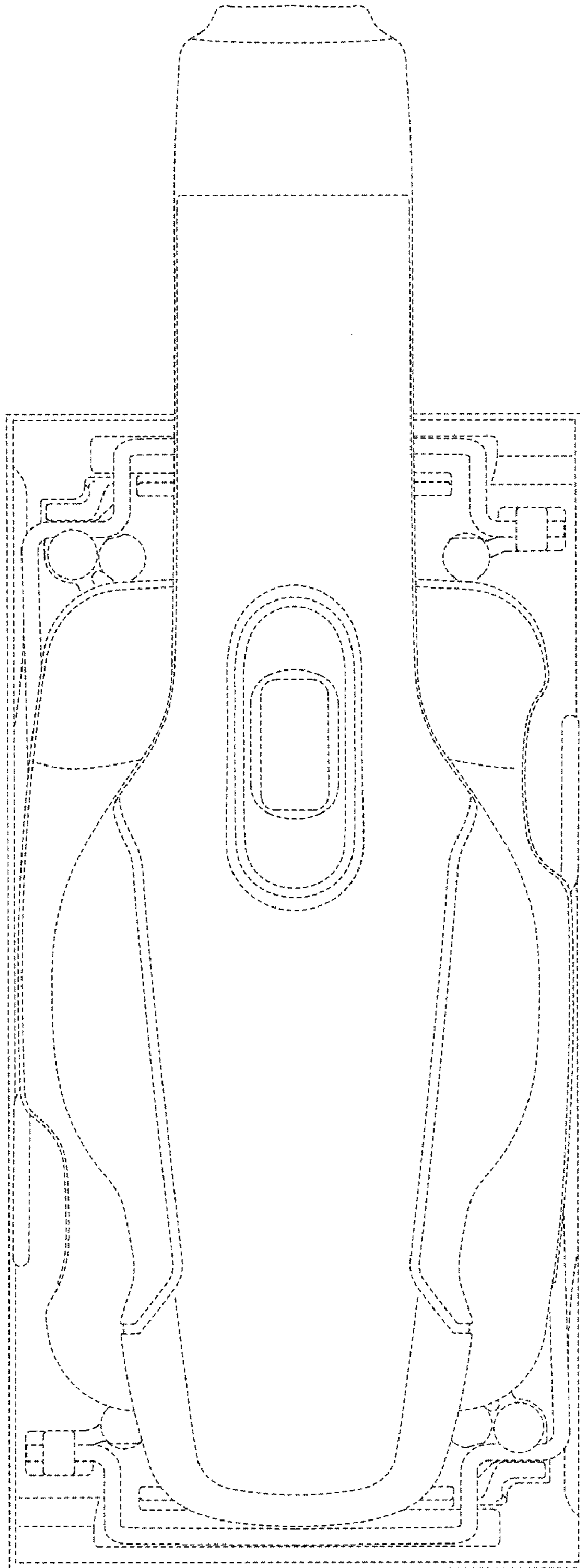

FIG. 6

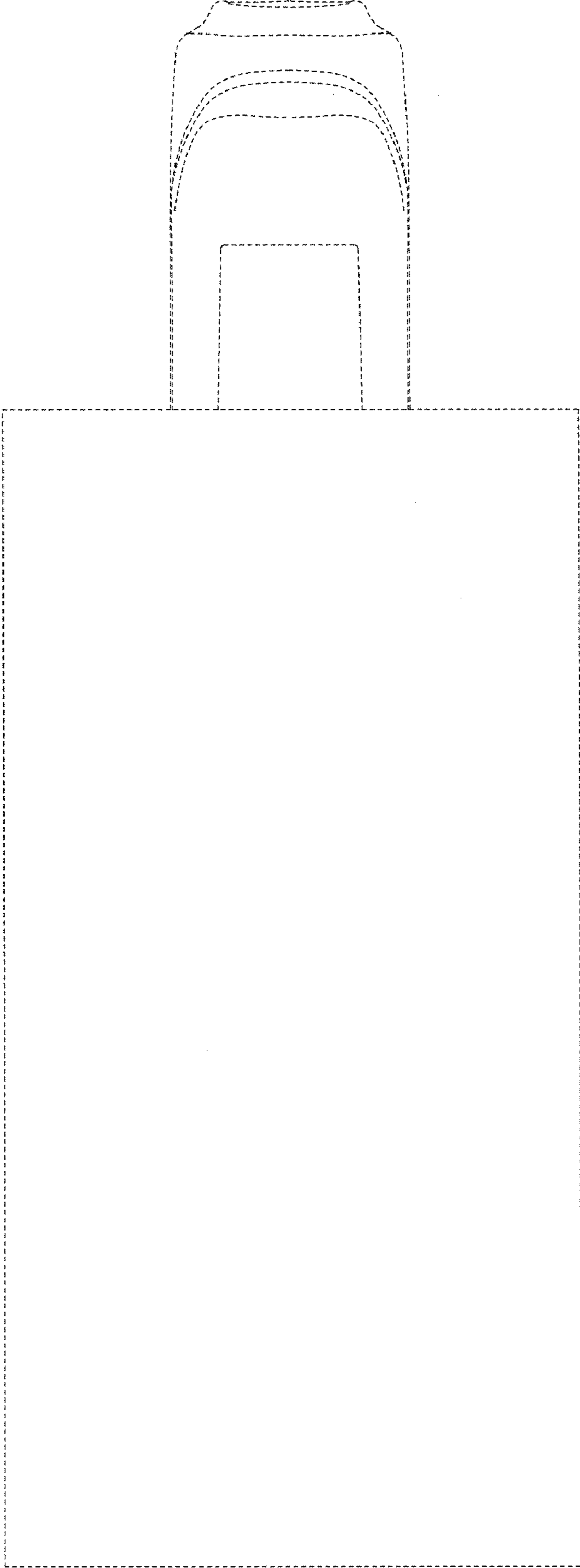

FIG. 7