



US00D650337S

(12) **United States Design Patent**  
**Bonomi**

(10) **Patent No.:** **US D650,337 S**

(45) **Date of Patent:** **\*\* Dec. 13, 2011**

(54) **ACTUATOR**

(75) **Inventor:** **Aldo Bonomi**, Brozzo (IT)

(73) **Assignee:** **Valbia S.r.l.**, Brozzo (Brescia) (IT)

(\*\*) **Term:** **14 Years**

(21) **Appl. No.:** **29/378,371**

(22) **Filed:** **Nov. 3, 2010**

(30) **Foreign Application Priority Data**

May 6, 2010 (EM) ..... 001212682-0001

(51) **LOC (9) Cl.** ..... **13-03**

(52) **U.S. Cl.** ..... **D13/158; D23/249**

(58) **Field of Classification Search** ..... D13/158,  
D13/162, 164, 177, 184, 199; 200/308, 520,  
200/5 A, 5 R, 83, 83 Q, 81 R, 81.4; D10/85,  
D10/96; D23/233, 248, 249; D15/143, 149  
See application file for complete search history.

(56) **References Cited**

**U.S. PATENT DOCUMENTS**

4,354,424 A \* 10/1982 Nordlund ..... 92/69 R  
D273,699 S \* 5/1984 Loup et al. .... D23/248

5,440,969 A \* 8/1995 Shin ..... 92/68  
D494,659 S \* 8/2004 Marinoni et al. .... D23/249  
D571,303 S \* 6/2008 Jokiniemi et al. .... D13/158  
D587,211 S \* 2/2009 Greenslade ..... D13/162  
D603,341 S \* 11/2009 Kawakami et al. .... D13/158  
D610,655 S \* 2/2010 Schmidt ..... D23/249  
D629,871 S \* 12/2010 Marinoni et al. .... D23/249  
D629,872 S \* 12/2010 Marinoni et al. .... D23/249  
D632,366 S \* 2/2011 Marinoni et al. .... D23/249

\* cited by examiner

*Primary Examiner* — Thomas Johannes

(74) *Attorney, Agent, or Firm* — Reising Ethington P.C.

(57) **CLAIM**

The ornamental design for an actuator, as shown and described.

**DESCRIPTION**

FIG. 1 shows a perspective view of an actuator, showing my new design;

FIG. 2 shows a top plan view thereof;

FIG. 3 shows a left side elevation view thereof;

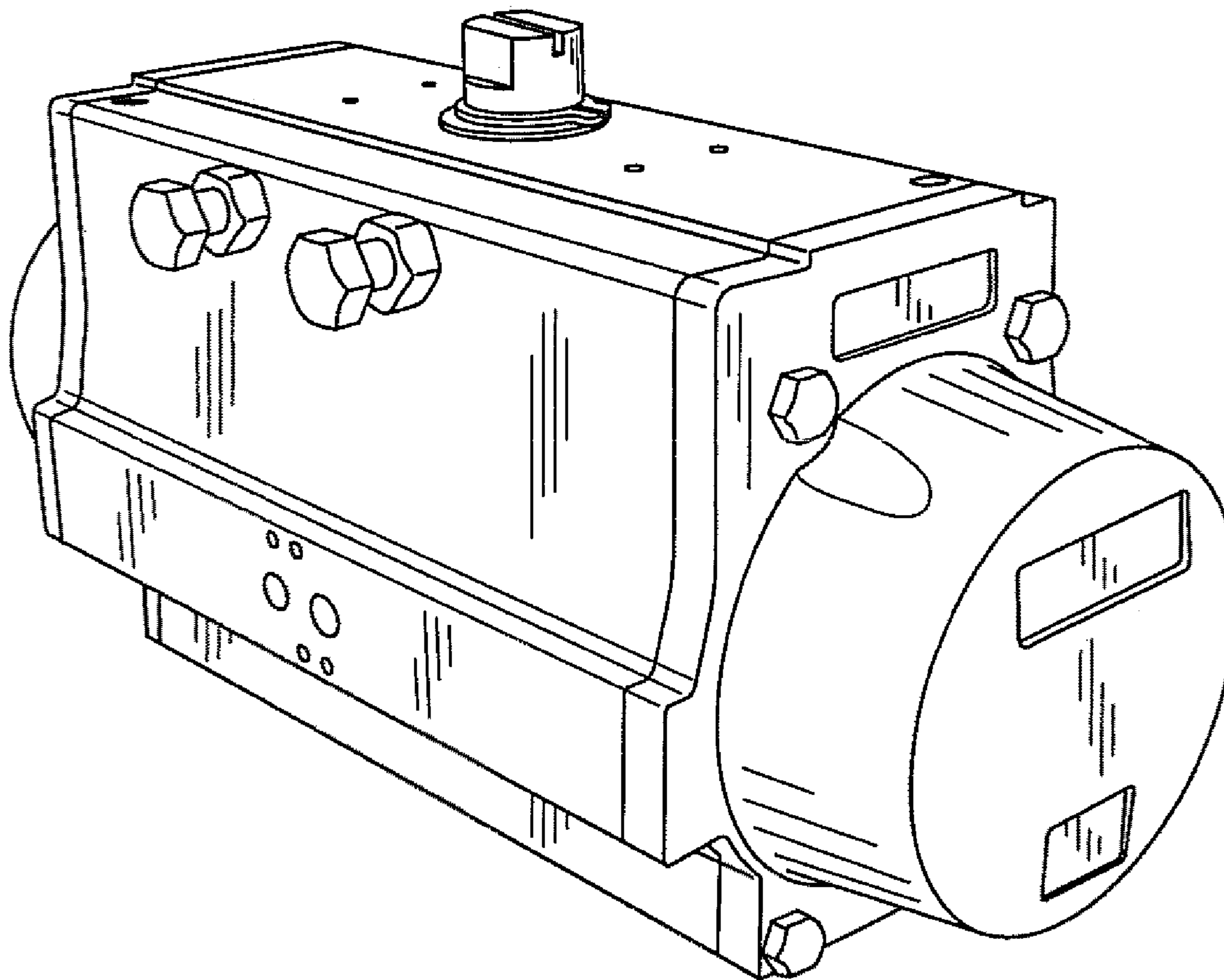
FIG. 4 shows a bottom plan thereof;

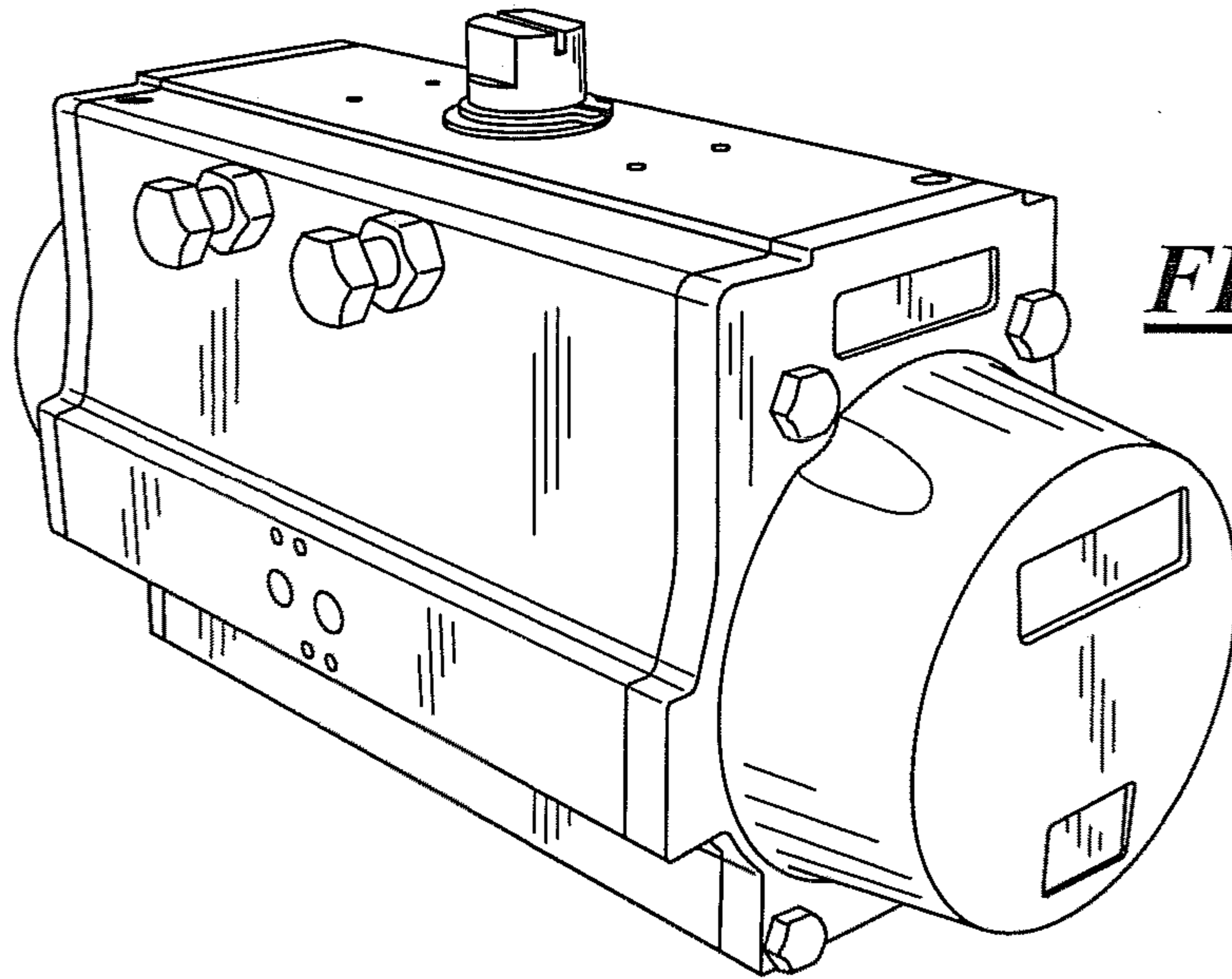
FIG. 5 shows a right side elevation view thereof;

FIG. 6 shows an end elevation view thereof; and,

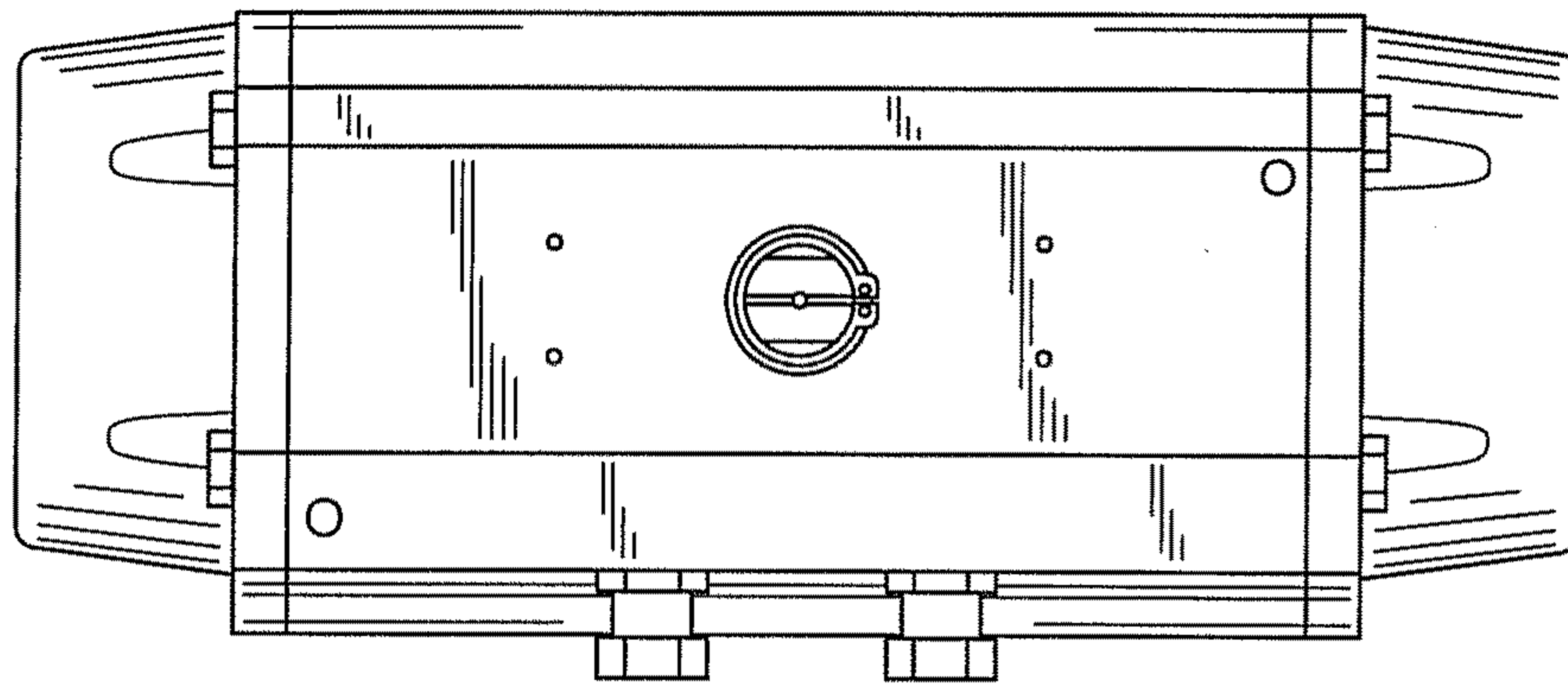
FIG. 7 shows an opposite end elevation view thereof.

**1 Claim, 2 Drawing Sheets**

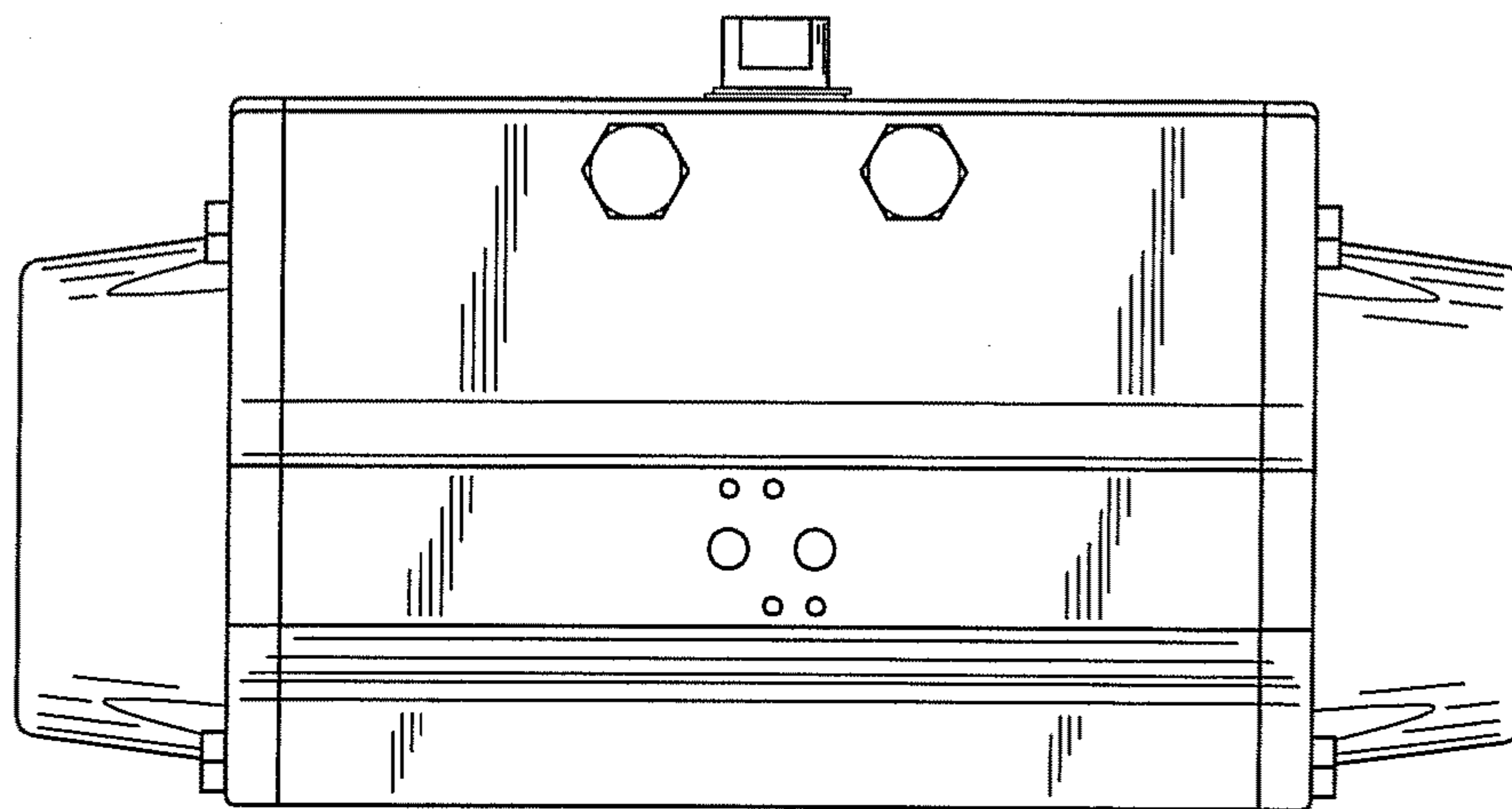




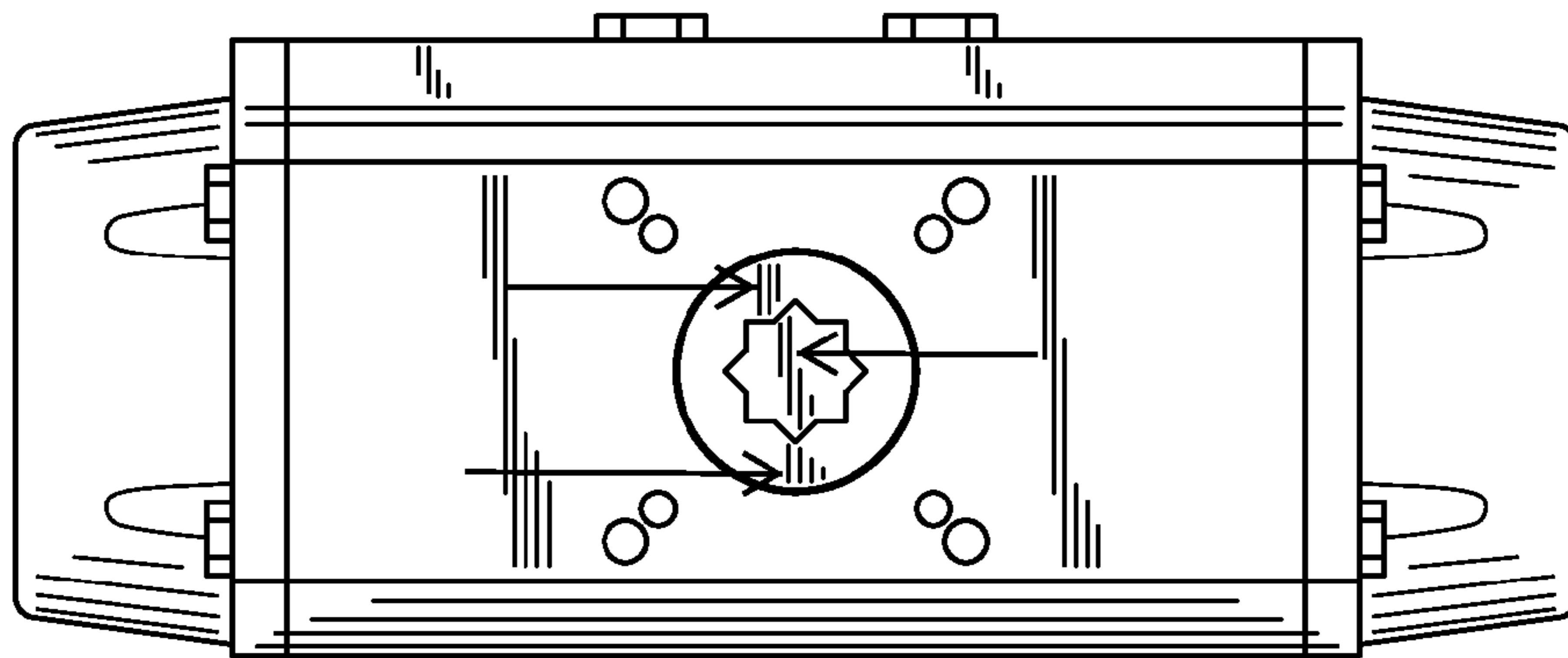
**FIG. 1**



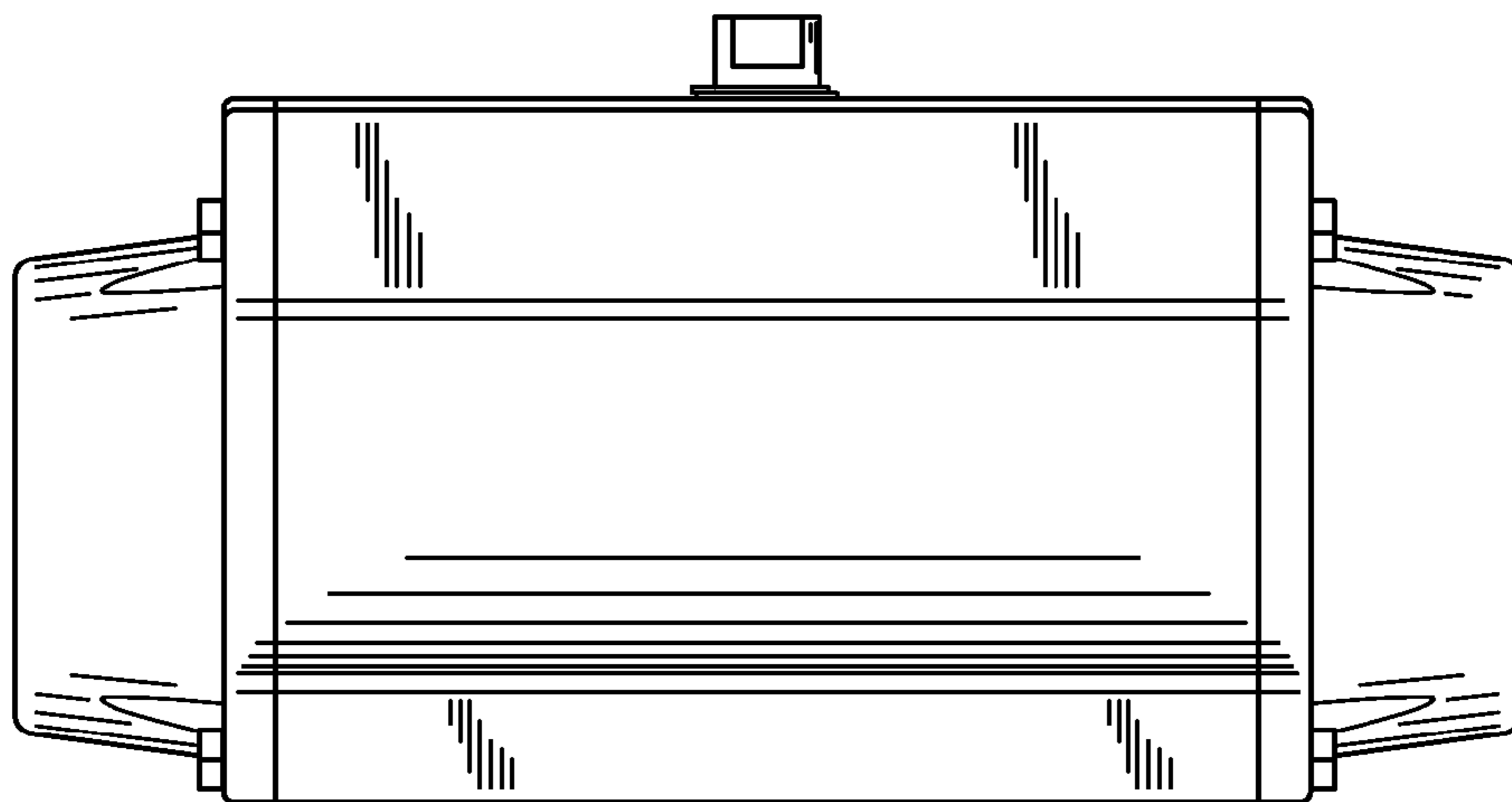
**FIG. 2**



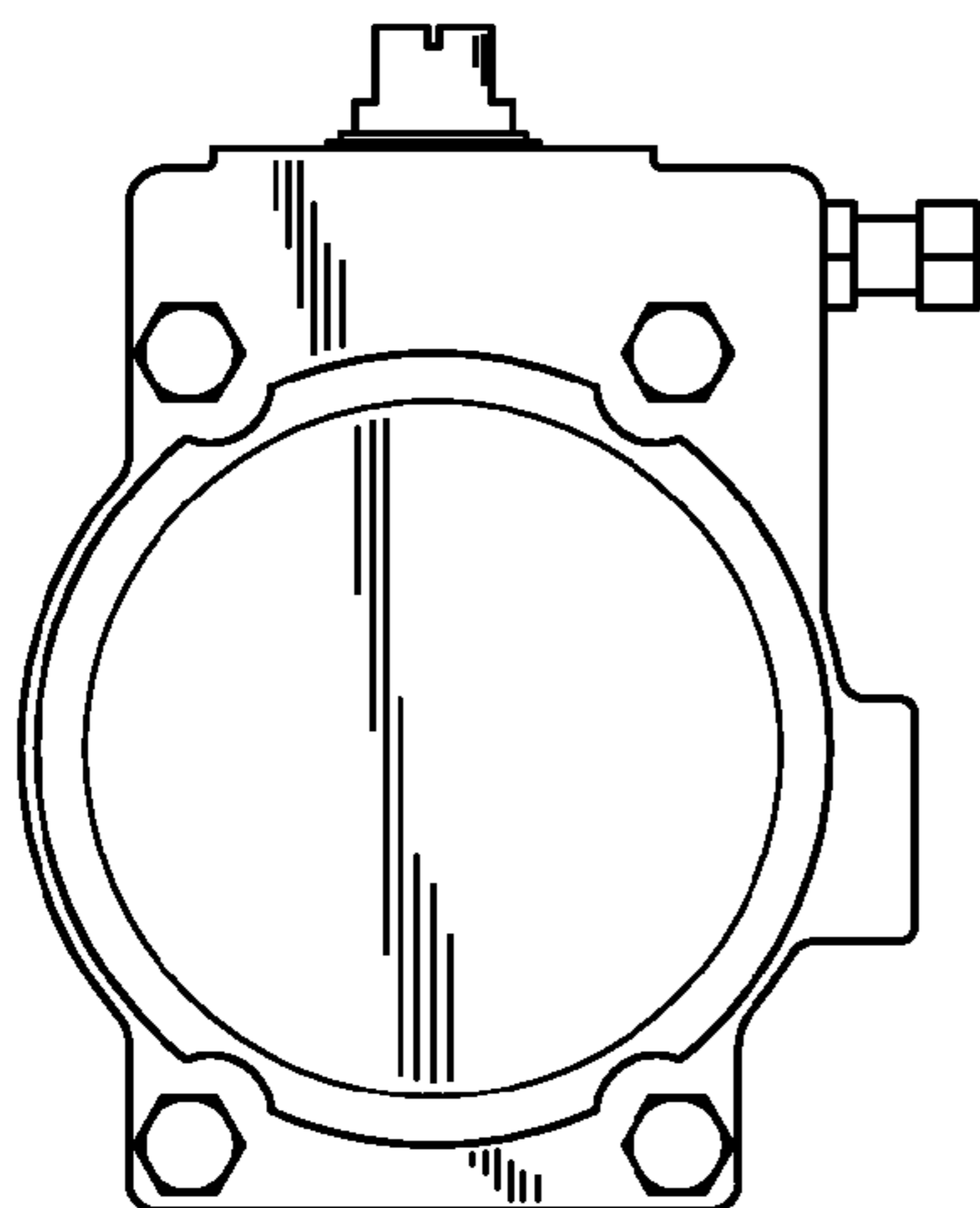
**FIG. 3**



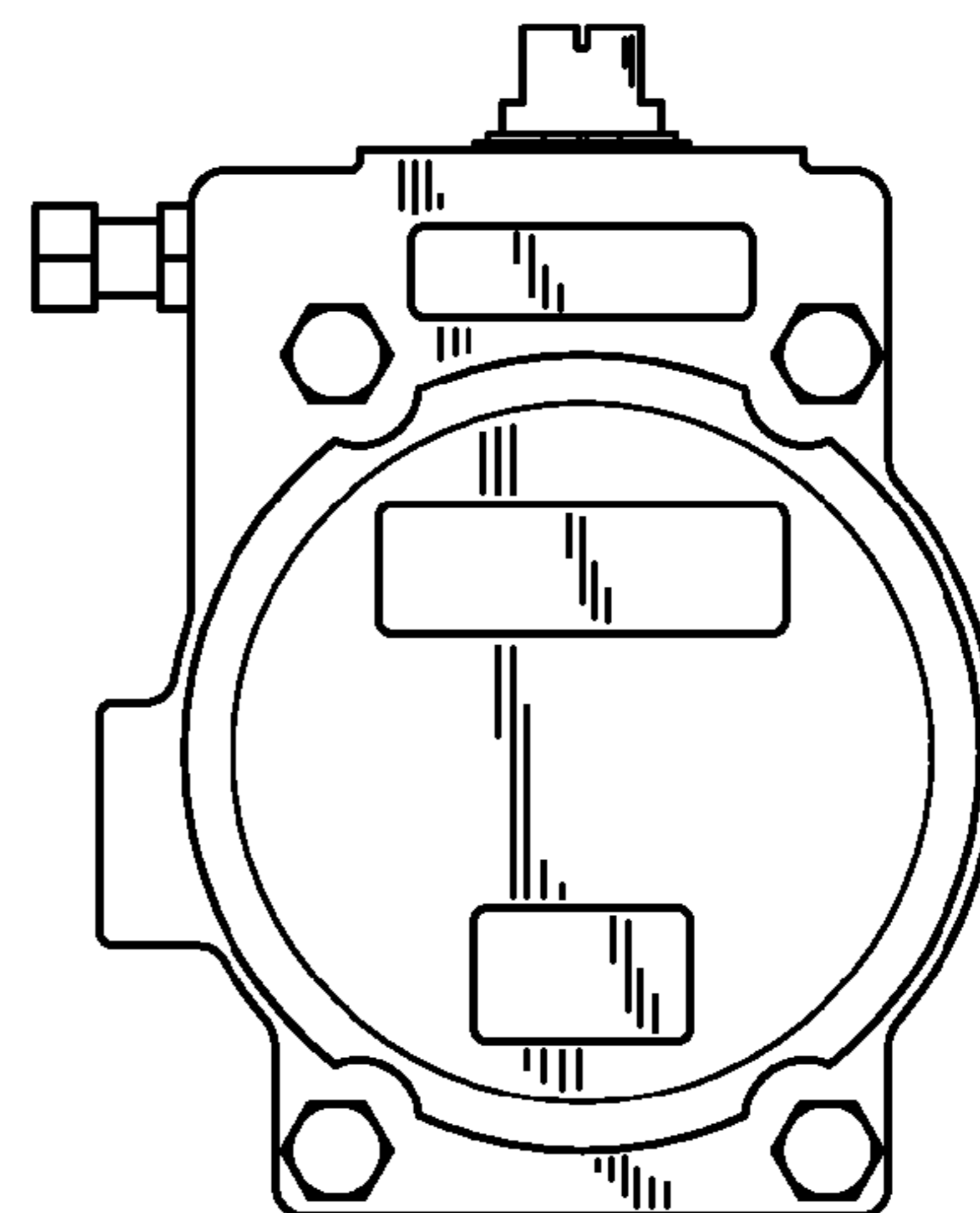
**FIG. 4**



**FIG. 5**



**FIG. 6**



**FIG. 7**

UNITED STATES PATENT AND TRADEMARK OFFICE  
**CERTIFICATE OF CORRECTION**

PATENT NO. : D650,337 S  
APPLICATION NO. : 29/378371  
DATED : December 13, 2011  
INVENTOR(S) : Aldo Bonomi

Page 1 of 2

It is certified that error appears in the above-identified patent and that said Letters Patent is hereby corrected as shown below:

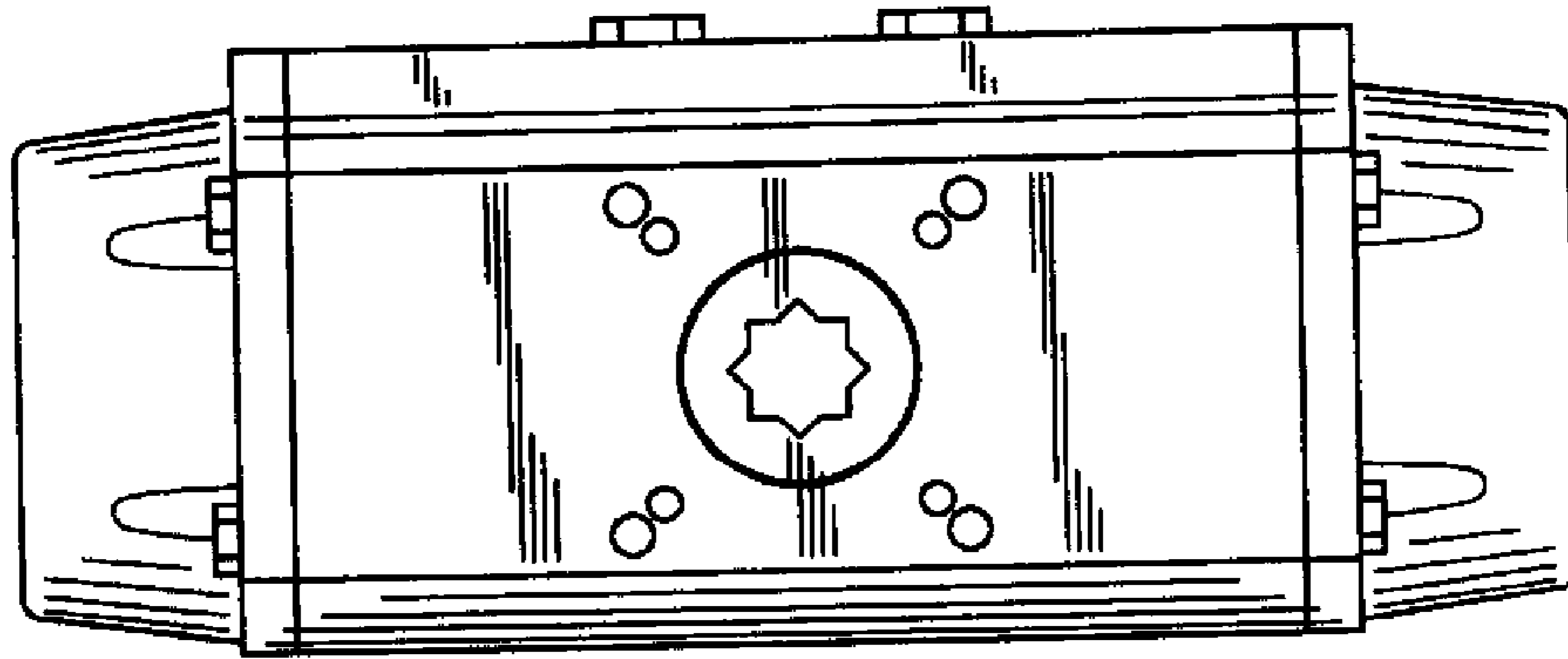
*In the Drawings*

The drawing sheet 2 of 2 consisting of Fig(s) 4, 5, 6 and 7 should be deleted and substitute therefore the attached drawing sheet 2 of 2 consisting of Fig(s) 4, 5, 6 and 7 reflecting changes to Fig. 4.

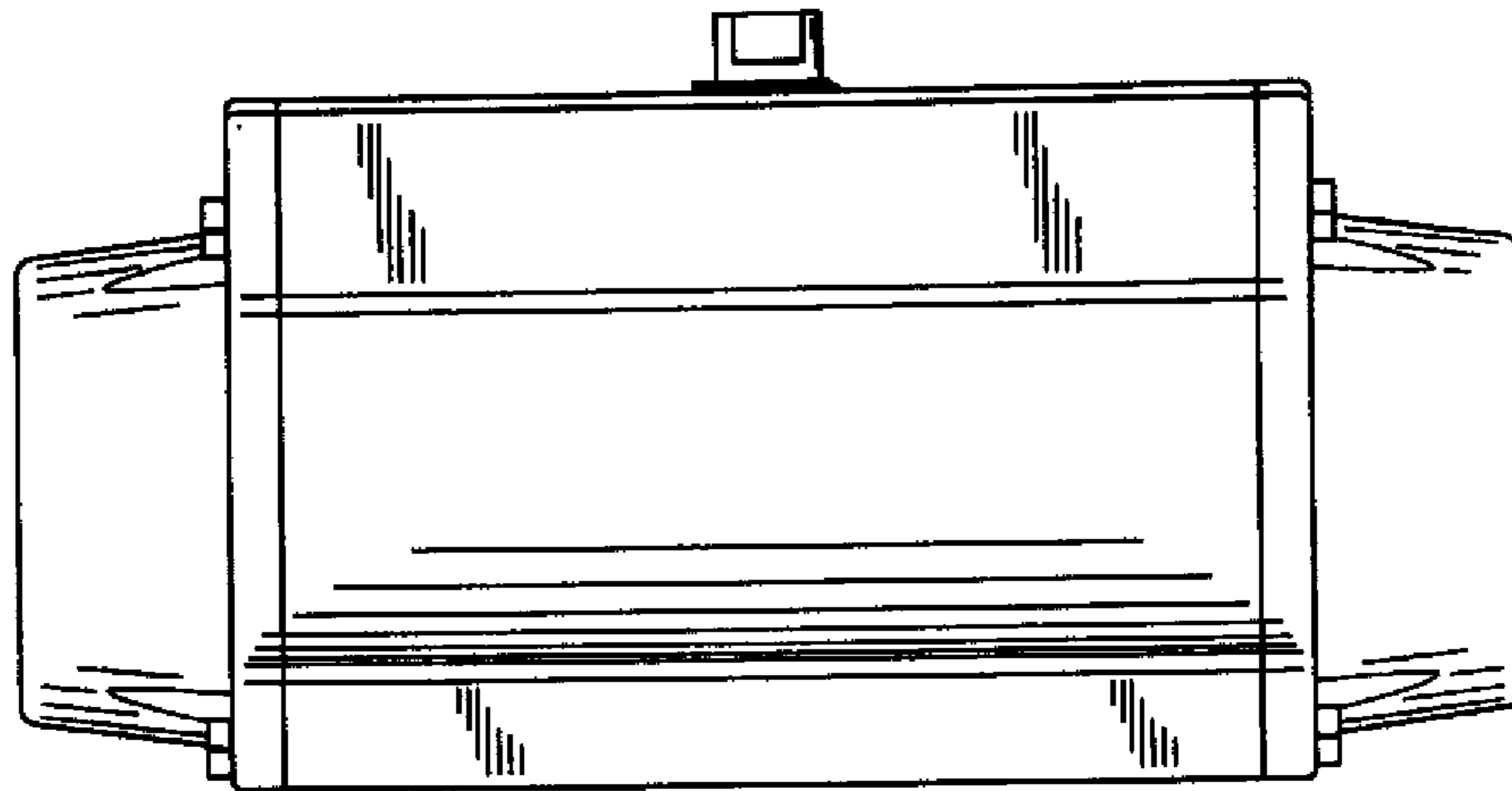
Signed and Sealed this  
Twenty-fourth Day of April, 2012

A handwritten signature in black ink that reads "David J. Kappos". The signature is written in a cursive style with a large, stylized 'D' and 'K'.

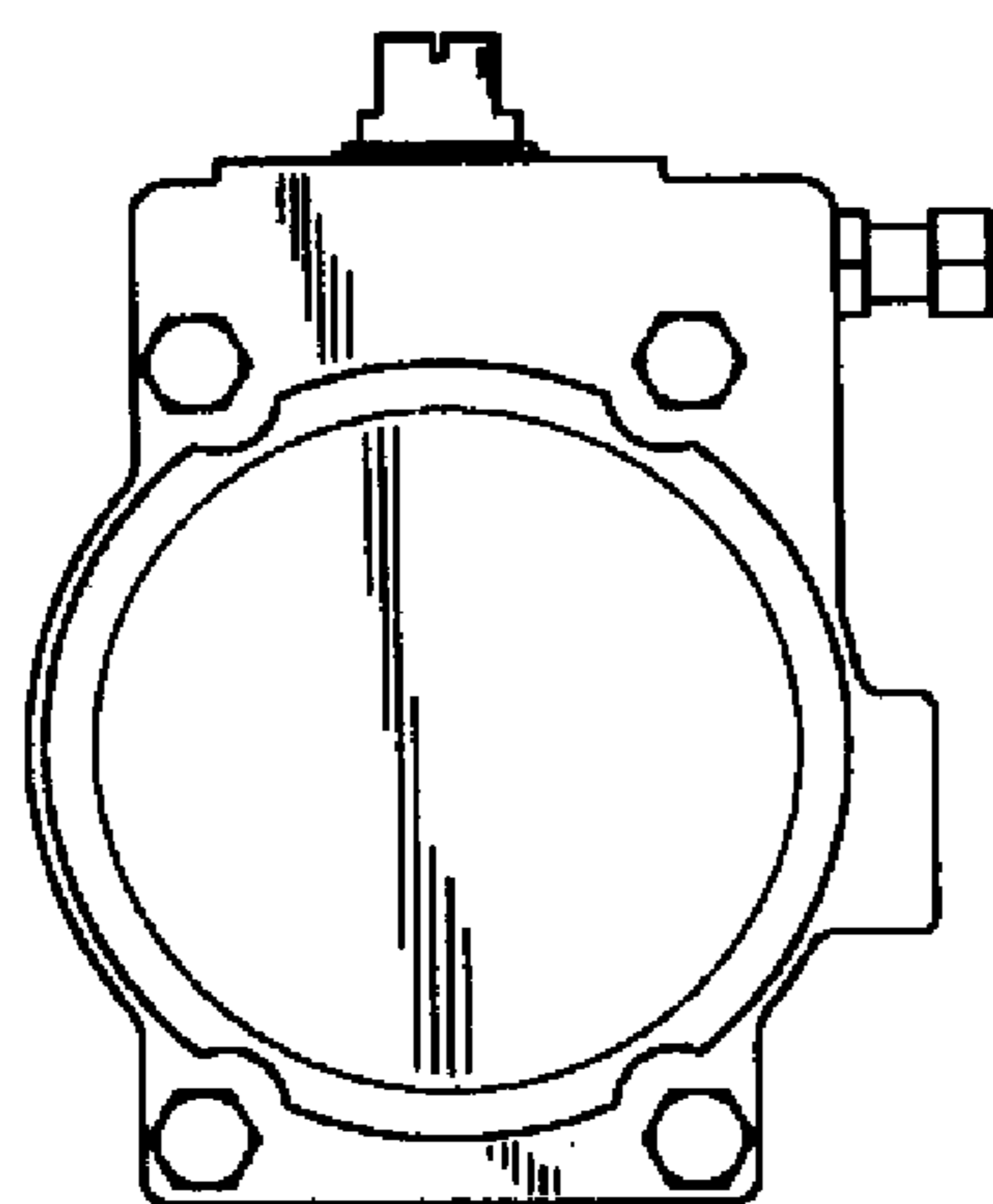
David J. Kappos  
*Director of the United States Patent and Trademark Office*



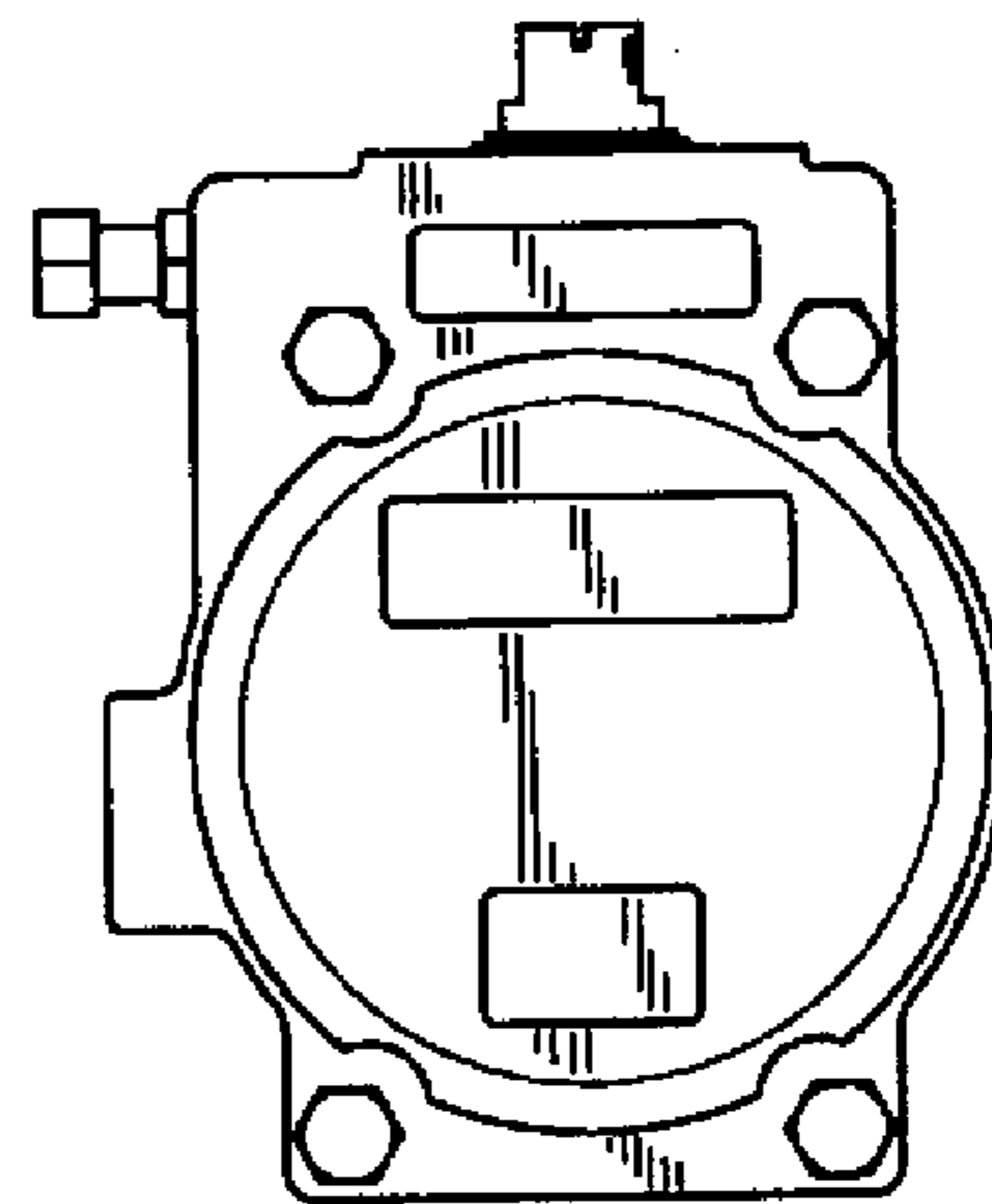
**FIG. 4**



**FIG. 5**



**FIG. 6**



**FIG. 7**