



US00D649924S

(12) **United States Design Patent**  
**Tureaud**

(10) **Patent No.:** **US D649,924 S**

(45) **Date of Patent:** **\*\* Dec. 6, 2011**

(54) **BUOYANCY ENGINE MODULE FOR AN UNMANNED UNDERWATER VEHICLE**

(74) *Attorney, Agent, or Firm* — Womble Carlyle Sandridge & Rice, PLLC

(75) Inventor: **Thomas F. Tureaud**, Fairfax, VA (US)

(57) **CLAIM**

The ornamental design for a buoyancy engine module for an unmanned underwater vehicle, as shown and described.

(73) Assignee: **Vehicle Control Technologies, Inc.**, Reston, VA (US)

(\*\*) Term: **14 Years**

**DESCRIPTION**

(21) Appl. No.: **29/355,946**

The present invention was made with Government support under Contract Nos. STTR N08-T016 and N00014-09-C-0527 awarded by the United States Navy. The Government has certain rights in the invention.

(22) Filed: **Feb. 17, 2010**

(51) **LOC (9) Cl.** ..... **12-06**

(52) **U.S. Cl.** ..... **D12/317; D12/308**

(58) **Field of Classification Search** ..... D12/214, D12/308, 317, 318; 114/20.1, 244, 245, 114/312, 315, 316, 318, 319, 322, 330–333, 114/337, 338; 440/49, 51, 53, 61 R, 61 T, 440/66, 76, 79–81, 89 R  
See application file for complete search history.

FIG. 1 is a perspective view of a buoyancy engine module for an unmanned underwater vehicle in accordance with a first embodiment of the present invention, wherein a centrally located pair of adjacent dashed lines is included for indicating that no particular length is being claimed;

FIG. 2 is a front elevation view of the apparatus of FIG. 1;

FIG. 3 is a rear elevation view of the apparatus of FIG. 1;

FIG. 4 is a right elevation view of the apparatus of FIG. 1;

FIG. 5 is a top plan view of the apparatus of FIG. 1;

FIG. 6 is a left elevation view of the apparatus of FIG. 1;

FIG. 7 is a bottom plan view of the apparatus of FIG. 1;

FIG. 8 is a perspective view of a buoyancy engine module for an unmanned underwater vehicle in accordance with a second embodiment of the present invention, wherein a centrally located pair of adjacent dashed lines is included for indicating that no particular length is being claimed;

FIG. 9 is a front elevation view of the apparatus of FIG. 8;

FIG. 10 is a rear elevation view of the apparatus of FIG. 8;

FIG. 11 is a right elevation view of the apparatus of FIG. 8;

FIG. 12 is a top plan view of the apparatus of FIG. 8;

FIG. 13 is a left elevation view of the apparatus of FIG. 8; and,

FIG. 14 is a bottom plan view of the apparatus of FIG. 8.

The broken lines shown are included for the purpose of illustrating the unclaimed portions of the article and forms no part of the claimed design.

(56) **References Cited**

**U.S. PATENT DOCUMENTS**

1,093,868	A	4/1914	Leighty
2,992,840	A	7/1961	Reynolds et al.
3,016,249	A	1/1962	Contreras et al.
3,105,453	A	10/1963	Hayes

(Continued)

**FOREIGN PATENT DOCUMENTS**

DE 39 27 725 A1 2/1991

**OTHER PUBLICATIONS**

Vehicle Control Technologies, Inc., "STTR Proposal No. N08A-016-0269—Expendable Glider for Oceanographic Research", Mar. 18, 2008, pp. 3-25.

(Continued)

*Primary Examiner* — Cynthia M Chin

**1 Claim, 14 Drawing Sheets**

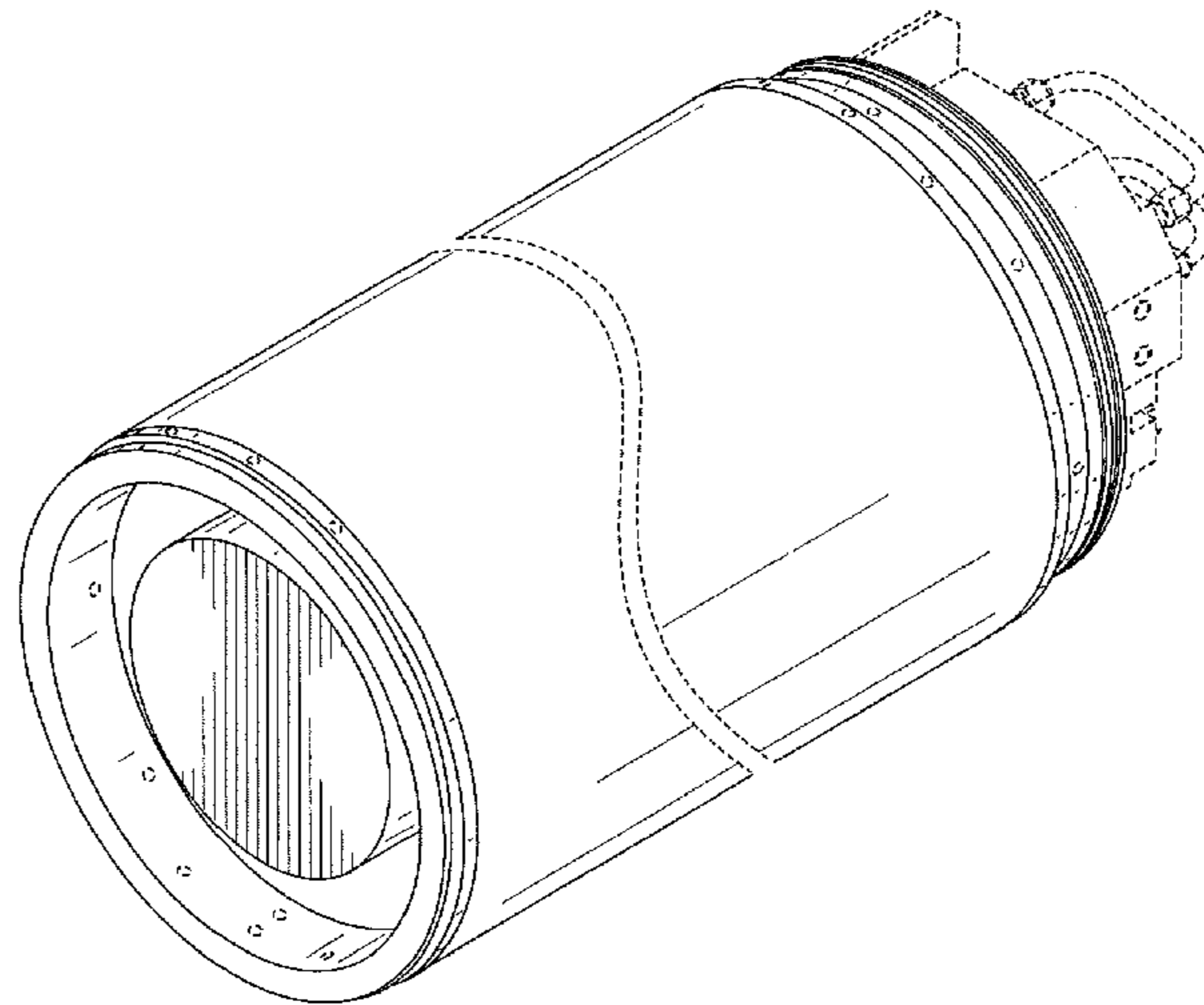
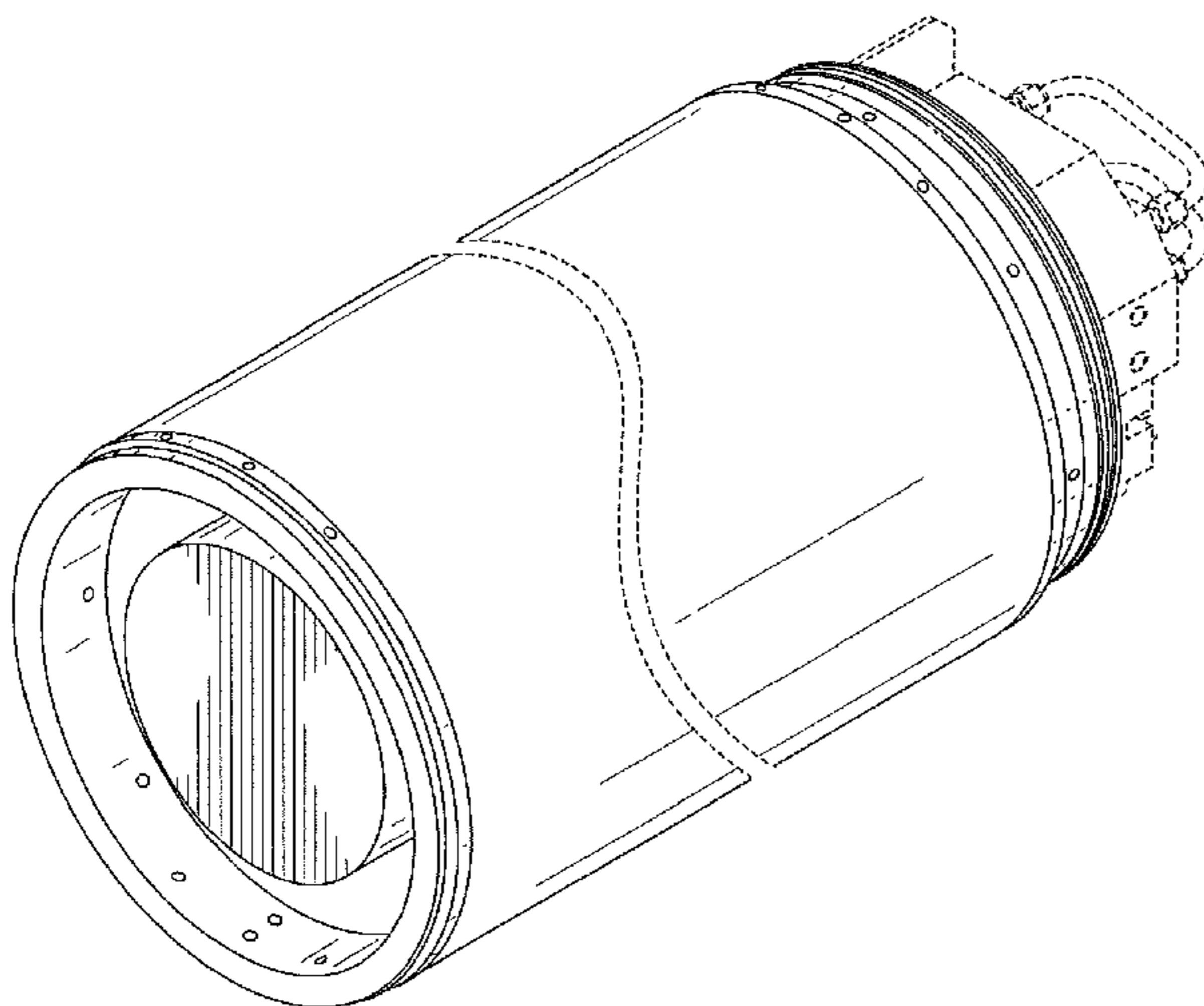

# US D649,924 S

Page 2

## U.S. PATENT DOCUMENTS

3,744,825 A 7/1973 Cooper et al.  
3,987,745 A 10/1976 Chaverebiere de Sal et al.  
4,204,806 A 5/1980 Blanchard  
4,271,552 A 6/1981 Sandler  
4,553,493 A 11/1985 Sadler et al.  
4,919,066 A \* 4/1990 Gongwer ..... 114/338  
5,105,753 A \* 4/1992 Chih et al. .... 114/315  
5,183,384 A 2/1993 Trumbly  
5,379,714 A \* 1/1995 Lewis et al. .... 114/315  
5,527,195 A \* 6/1996 Neisen ..... 440/89 R  
5,660,135 A \* 8/1997 Gomes et al. .... 114/312  
5,686,694 A 11/1997 Hillenbrand et al.  
5,708,230 A 1/1998 Woodall, Jr. et al.  
D393,618 S \* 4/1998 Gustavsson et al. .... D12/214  
5,786,545 A 7/1998 Hillenbrand  
D435,238 S 12/2000 Neisen  
D442,906 S 5/2001 Prokop  
6,359,834 B1 3/2002 English  
6,390,012 B1 5/2002 Watt et al.  
D459,285 S \* 6/2002 Rietsch ..... D12/214  
6,600,695 B1 7/2003 Nugent et al.  
6,738,314 B1 5/2004 Teeter et al.  
6,766,745 B1 7/2004 Kuklinski et al.  
6,854,410 B1 2/2005 King et al.  
7,000,560 B2 2/2006 Wingett et al.  
D518,768 S 4/2006 Mah et al.  
7,250,568 B1 7/2007 Dow et al.

7,337,741 B1 \* 3/2008 Ansay et al. .... 114/239  
D576,539 S 9/2008 Tymark et al.  
7,533,625 B2 5/2009 Lambertus et al.  
2008/0041293 A1 2/2008 Diorio et al.  
2008/0041294 A1 2/2008 Diorio et al.

## OTHER PUBLICATIONS

U.S. Appl. No. 29/351,242; filed Dec. 2, 2009; In re: Douglas E. Humphreys et al., entitled "Tail Module for an Unmanned Underwater Vehicle".

U.S. Navy, Naval Education and Training Professional Development and Technology Center, "Nonresident Training Course—Airman NAVEDTRA 14014", Jul. 2000, Cover Page, pp. i and 8-1 thru 8-36. Patrick McSherry, "Whitehead Torpedo", <http://www.spanamwar.com/torpedo.htm>, pp. 1-4.

Clampco Products, Inc., "Product Catalog—Manufacturers of Engineered Joining Solutions for the Clamping Industry", Cover Pages. and pp. 1-37.

Notice of Allowability for U.S. Appl. No. 29/351,242, filed Dec. 2, 2009; In re: Humphreys et al., entitled Tail Module for an Unmanned Underwater Vehicle.

Payment of Issue Fee for U.S. Appl. No. 29/351,242, filed Dec. 2, 2009; In re: Humphreys et al., entitled Tail Module for an Unmanned Underwater Vehicle.

\* cited by examiner

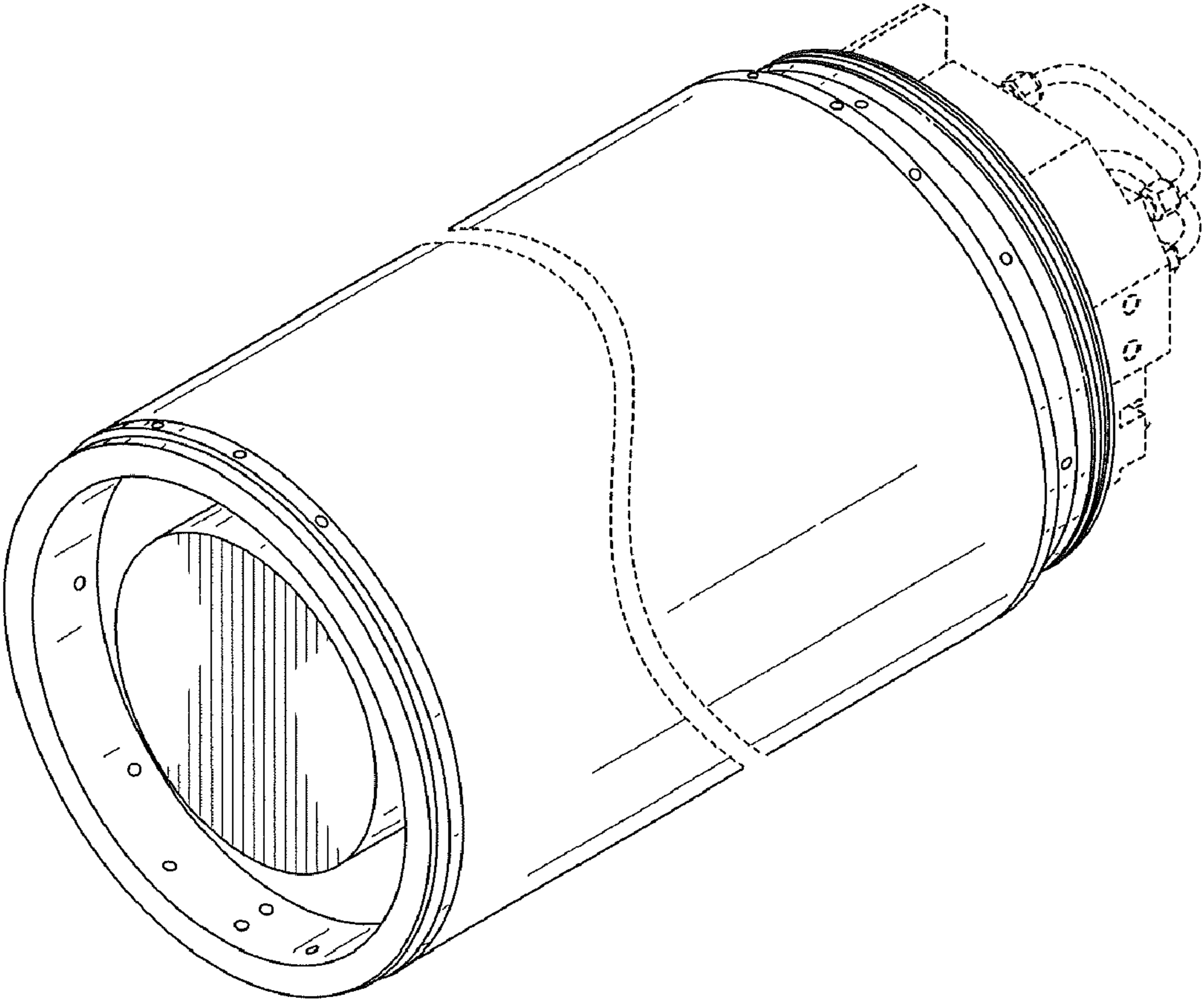

FIG. 1

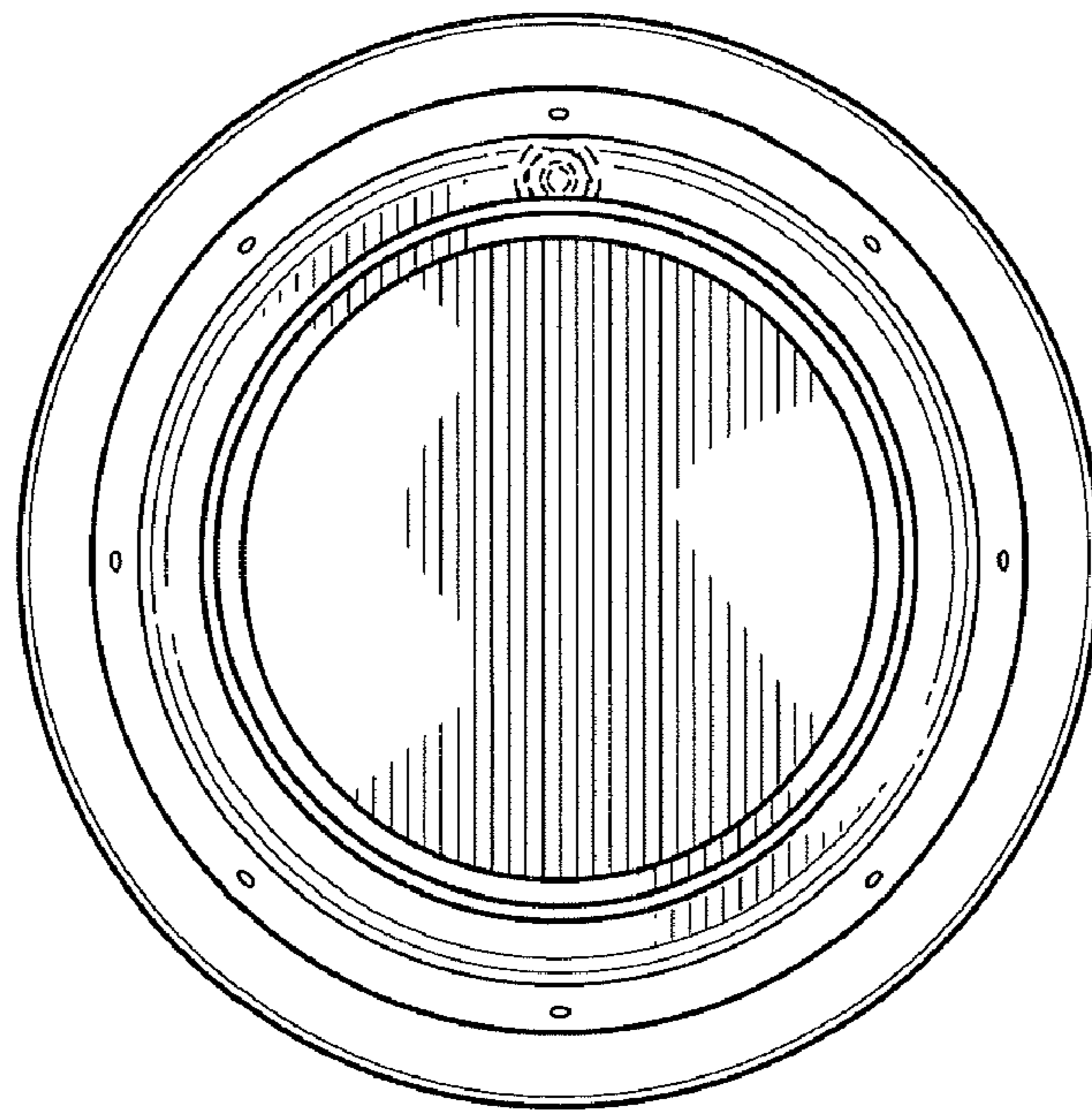
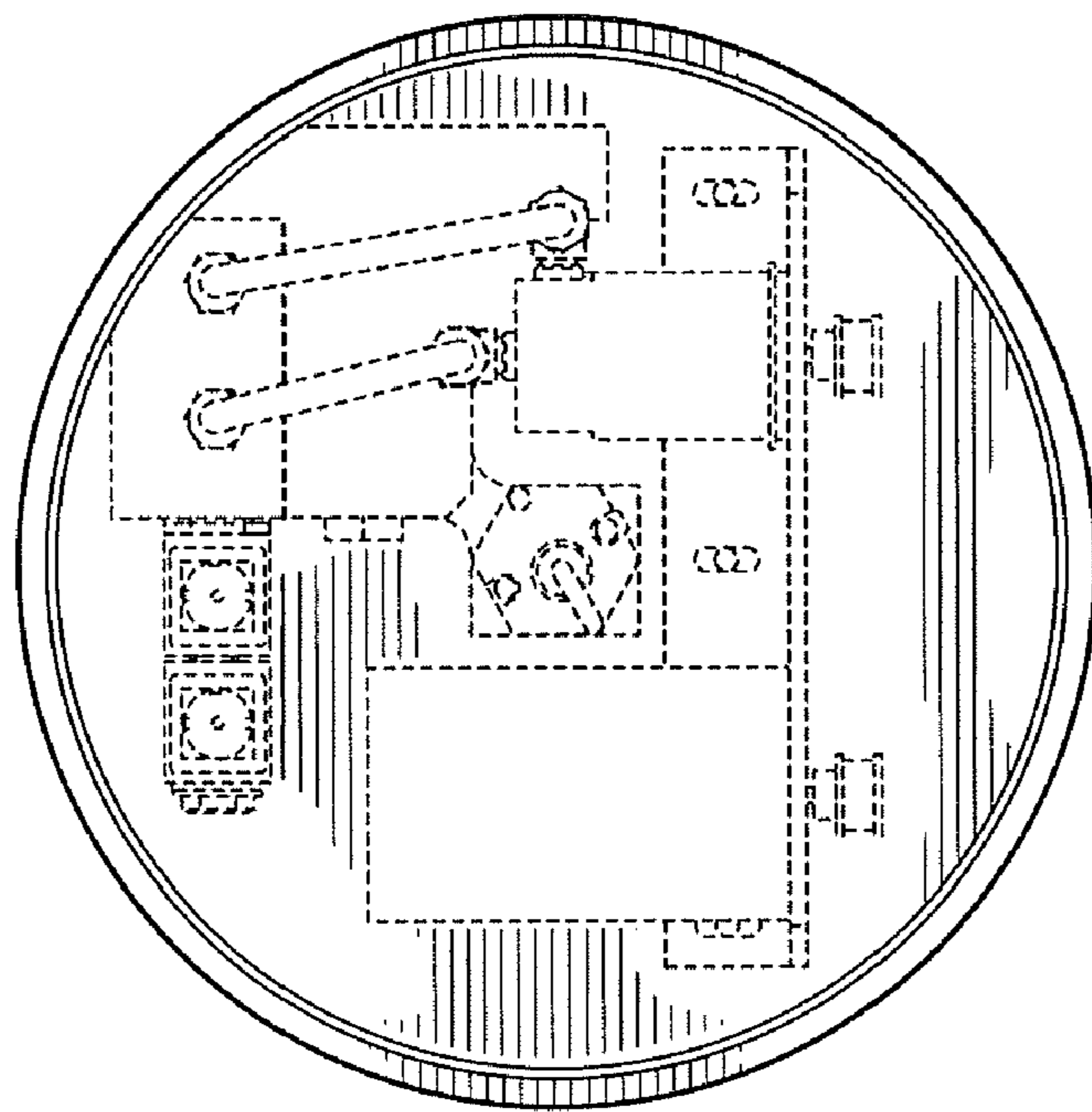

FIG. 2



**FIG. 3**

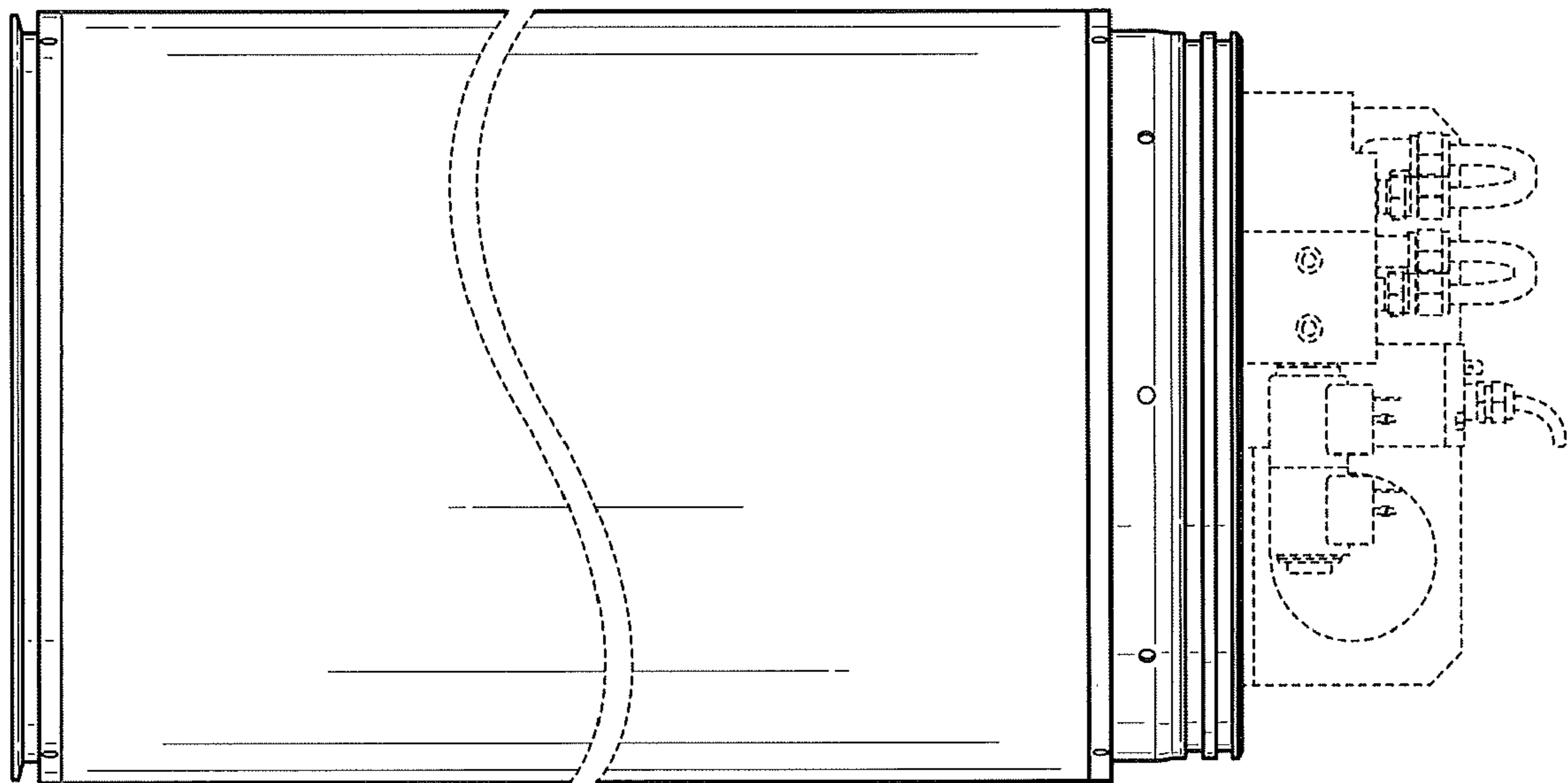

FIG. 4

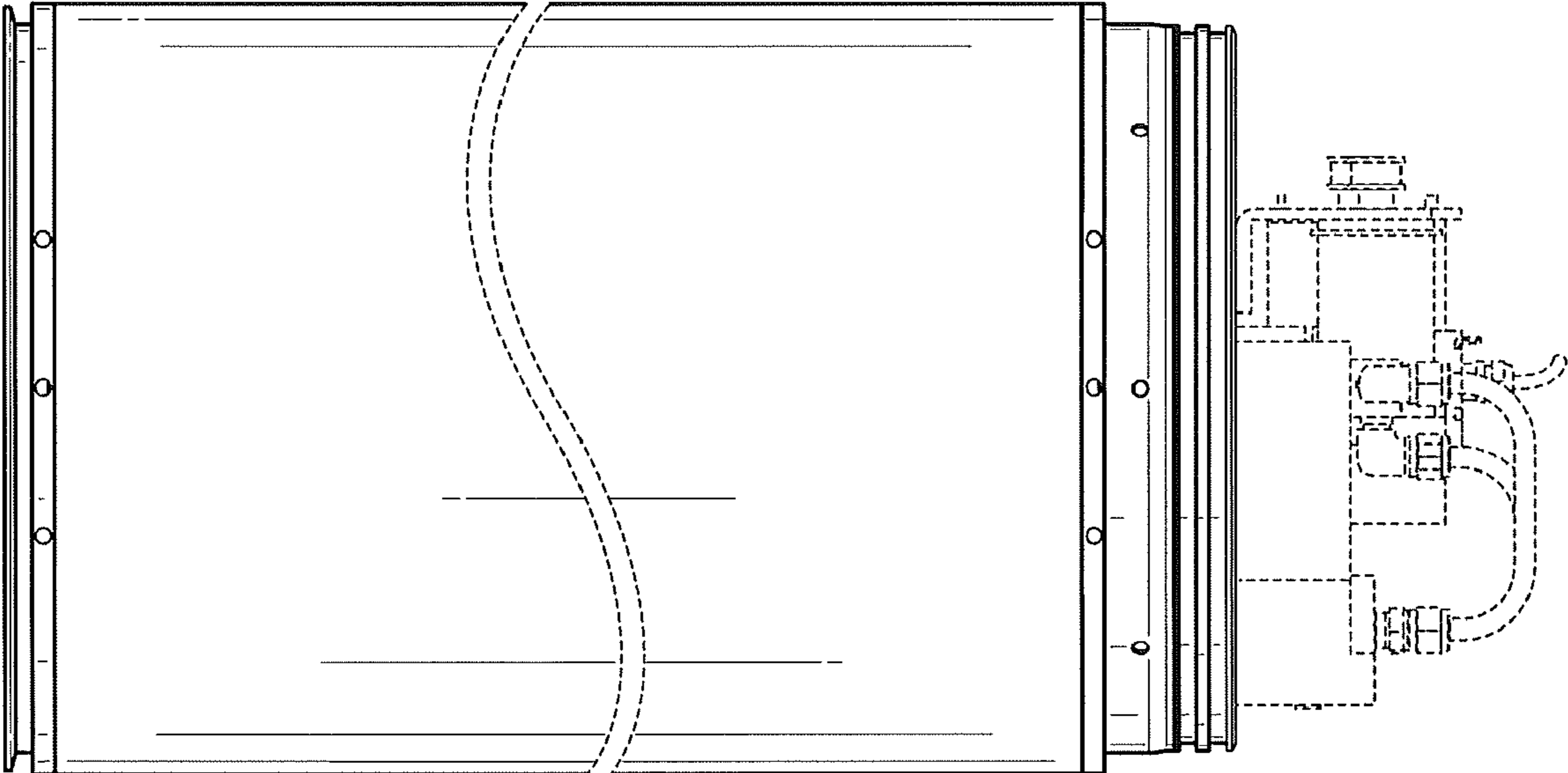

FIG. 5

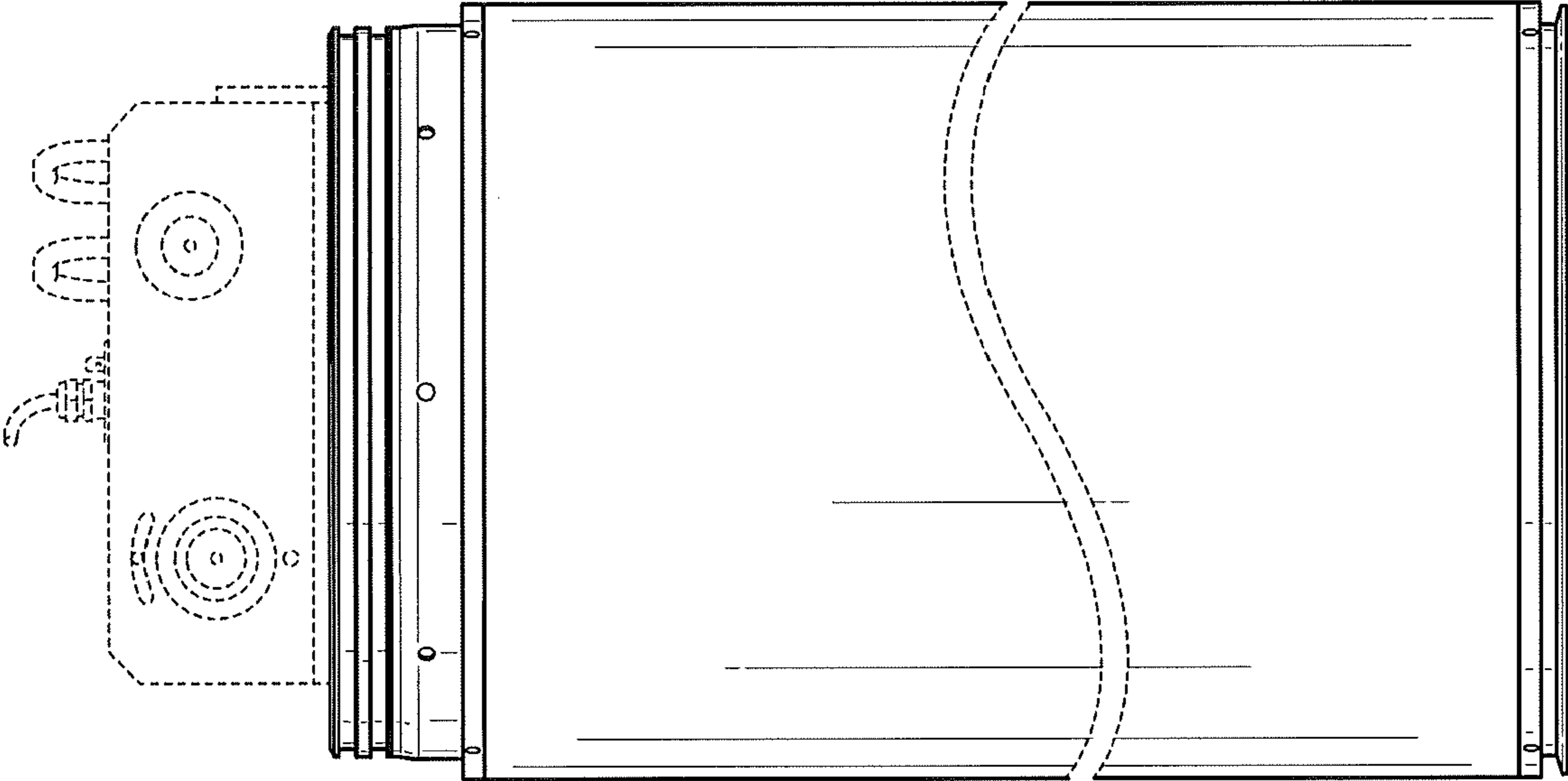

FIG. 6



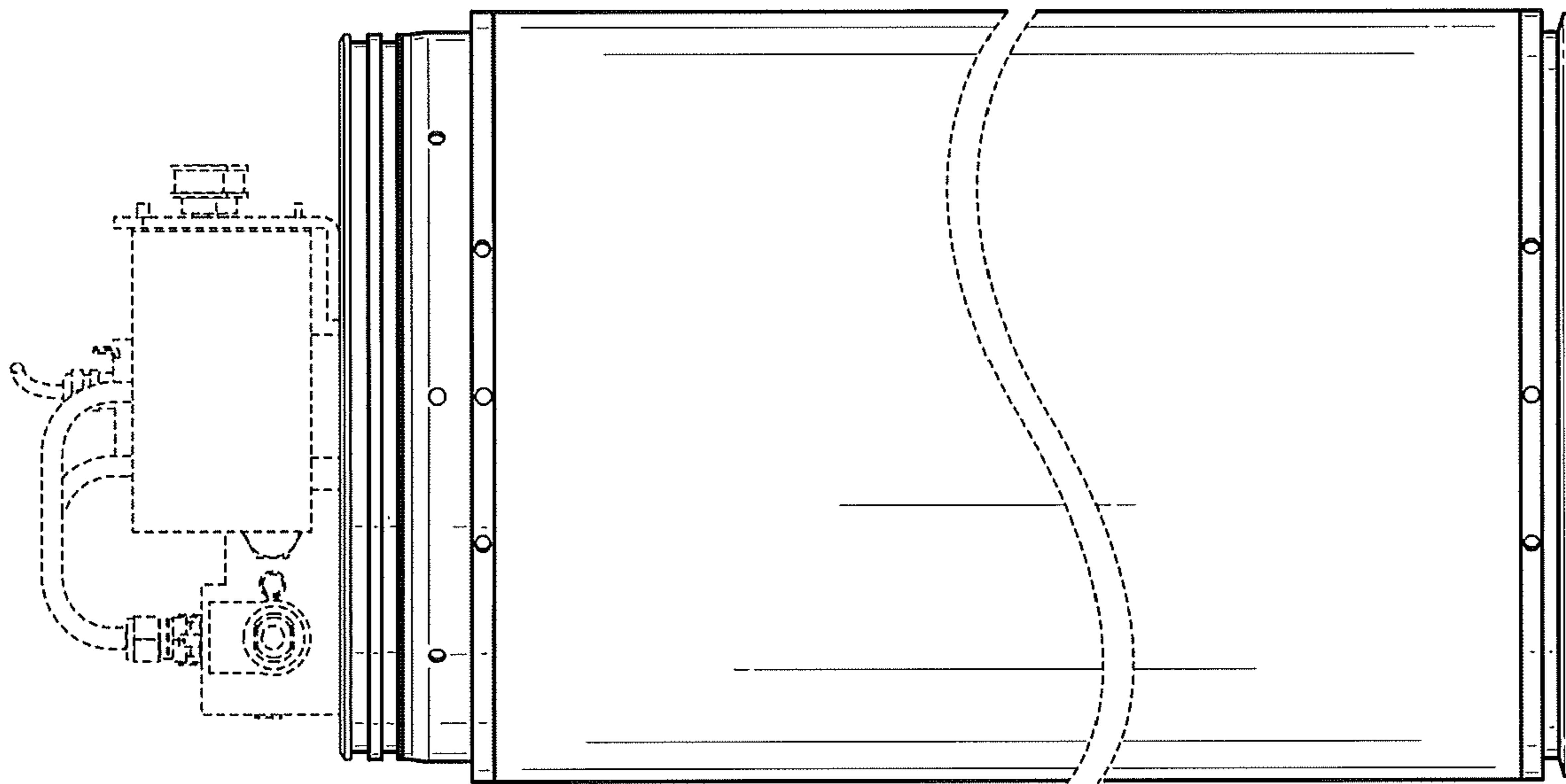

FIG. 7

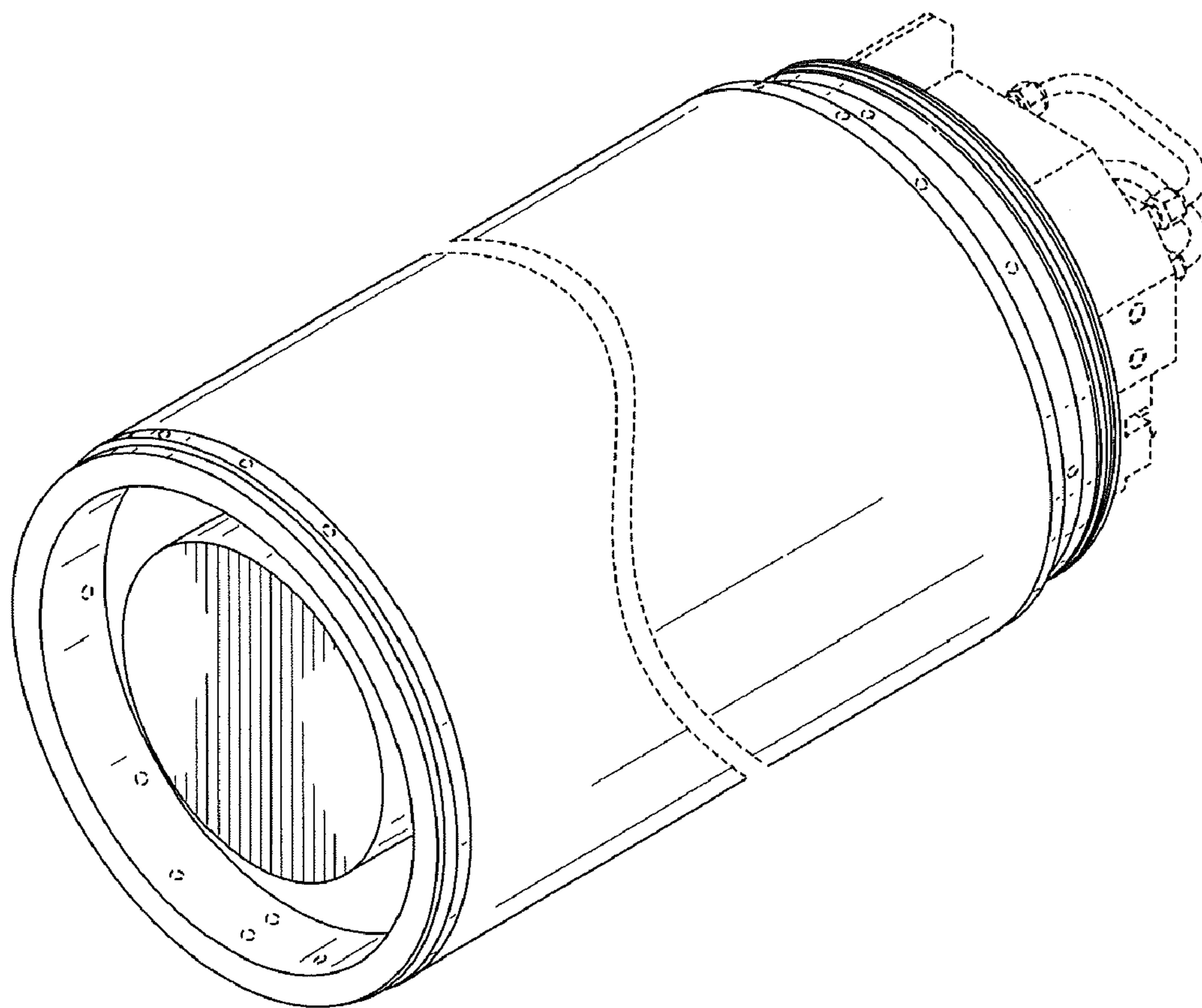

FIG. 8

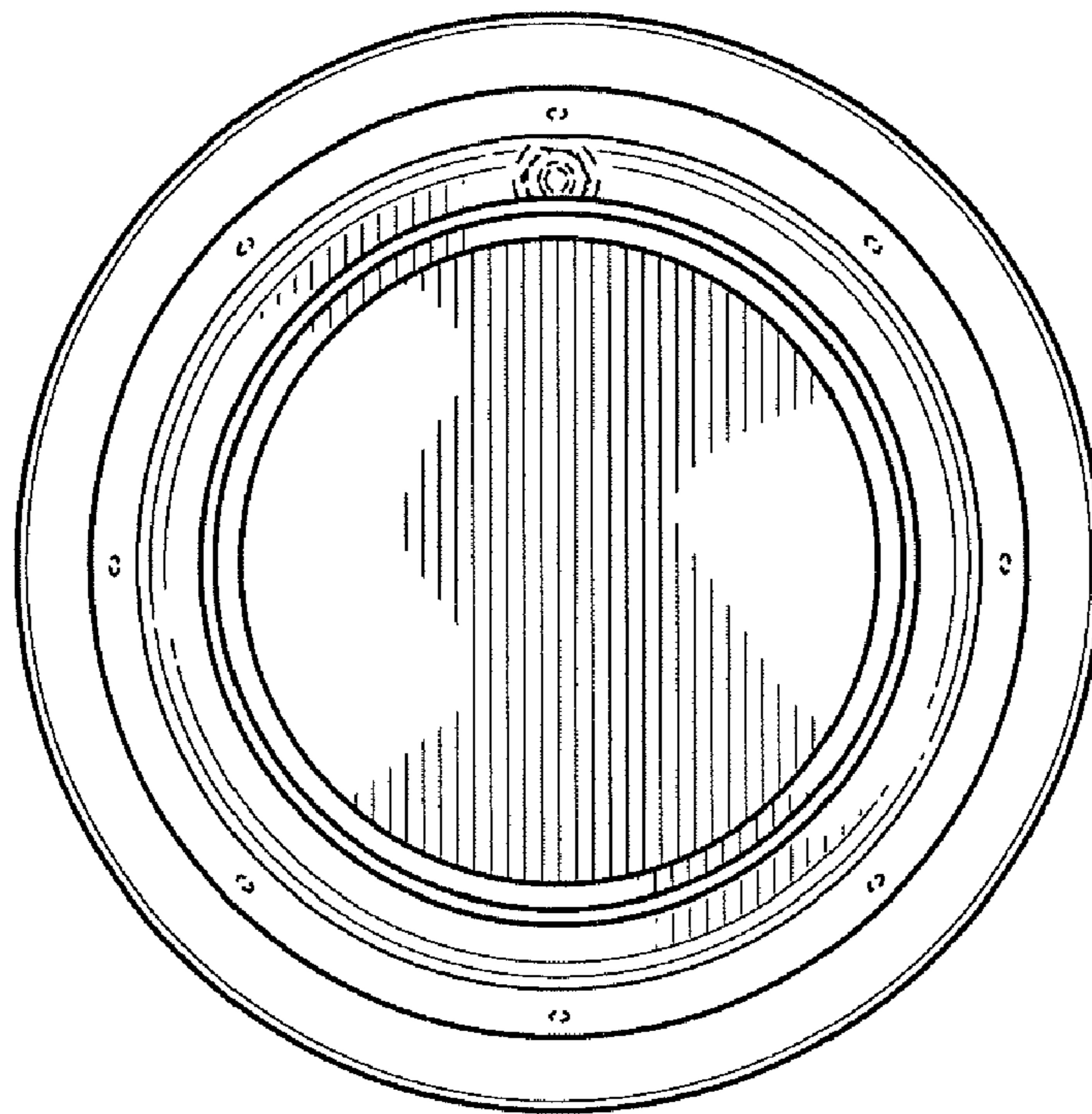
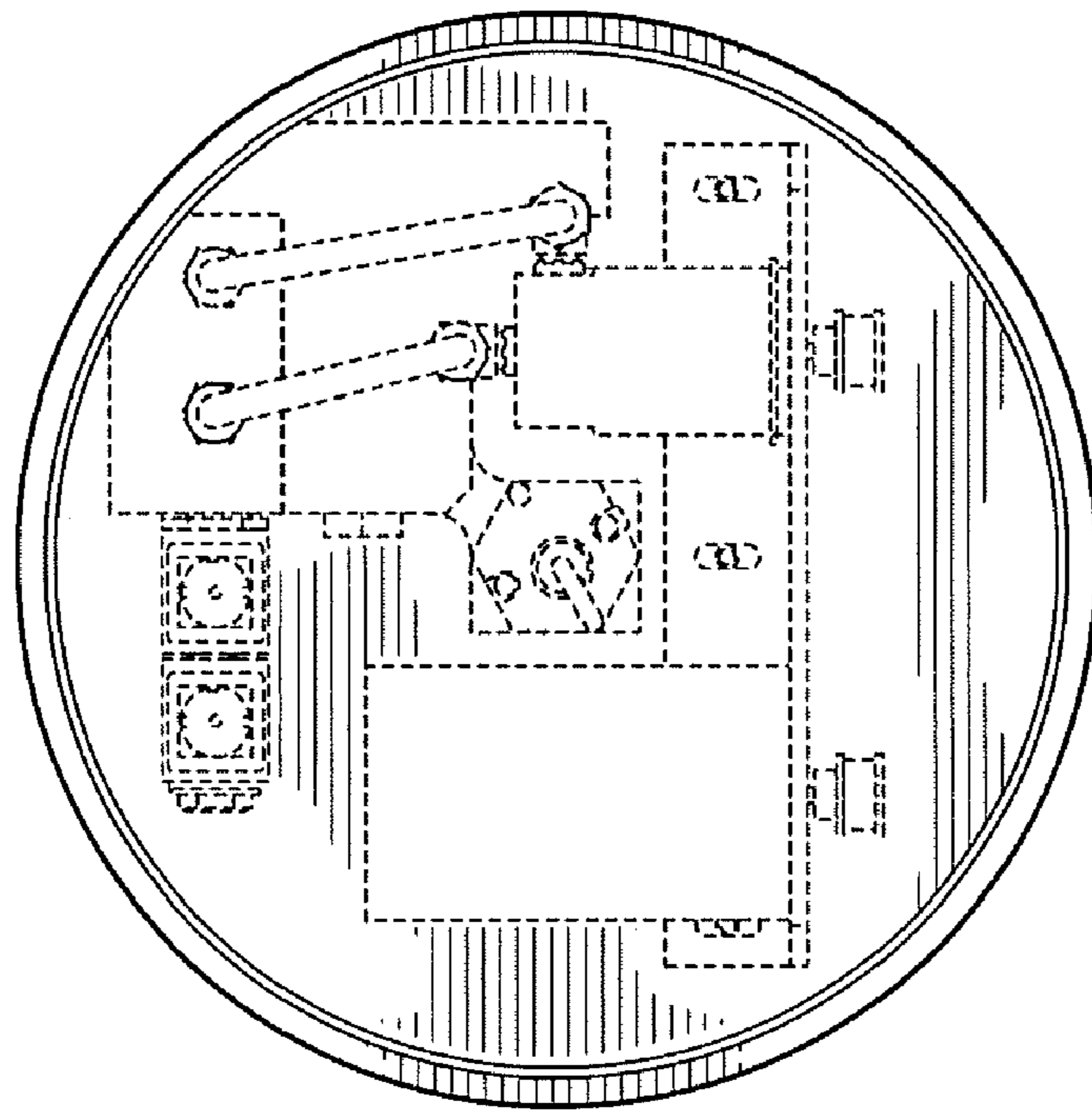

FIG. 9



**FIG. 10**

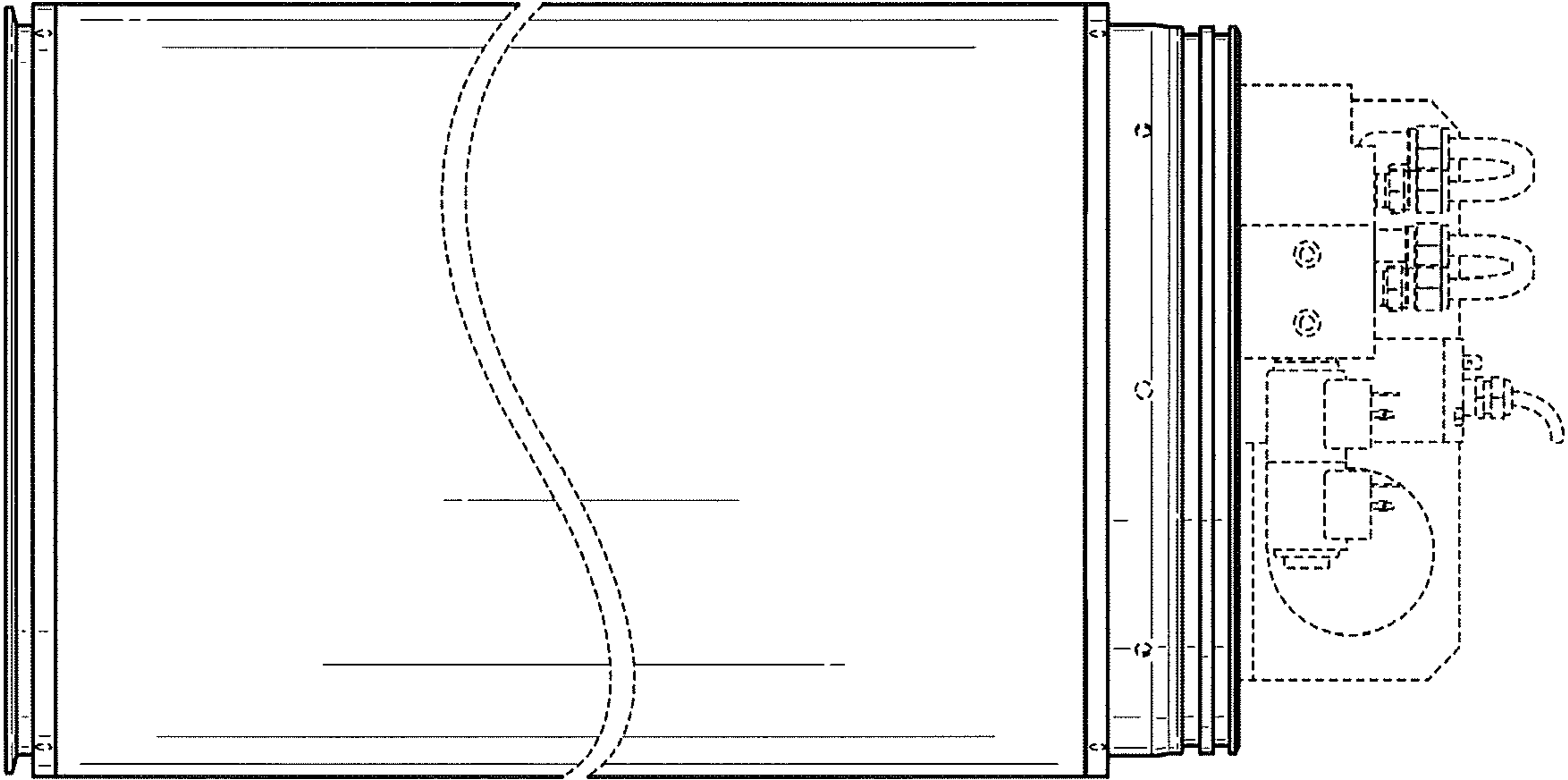

FIG. 11

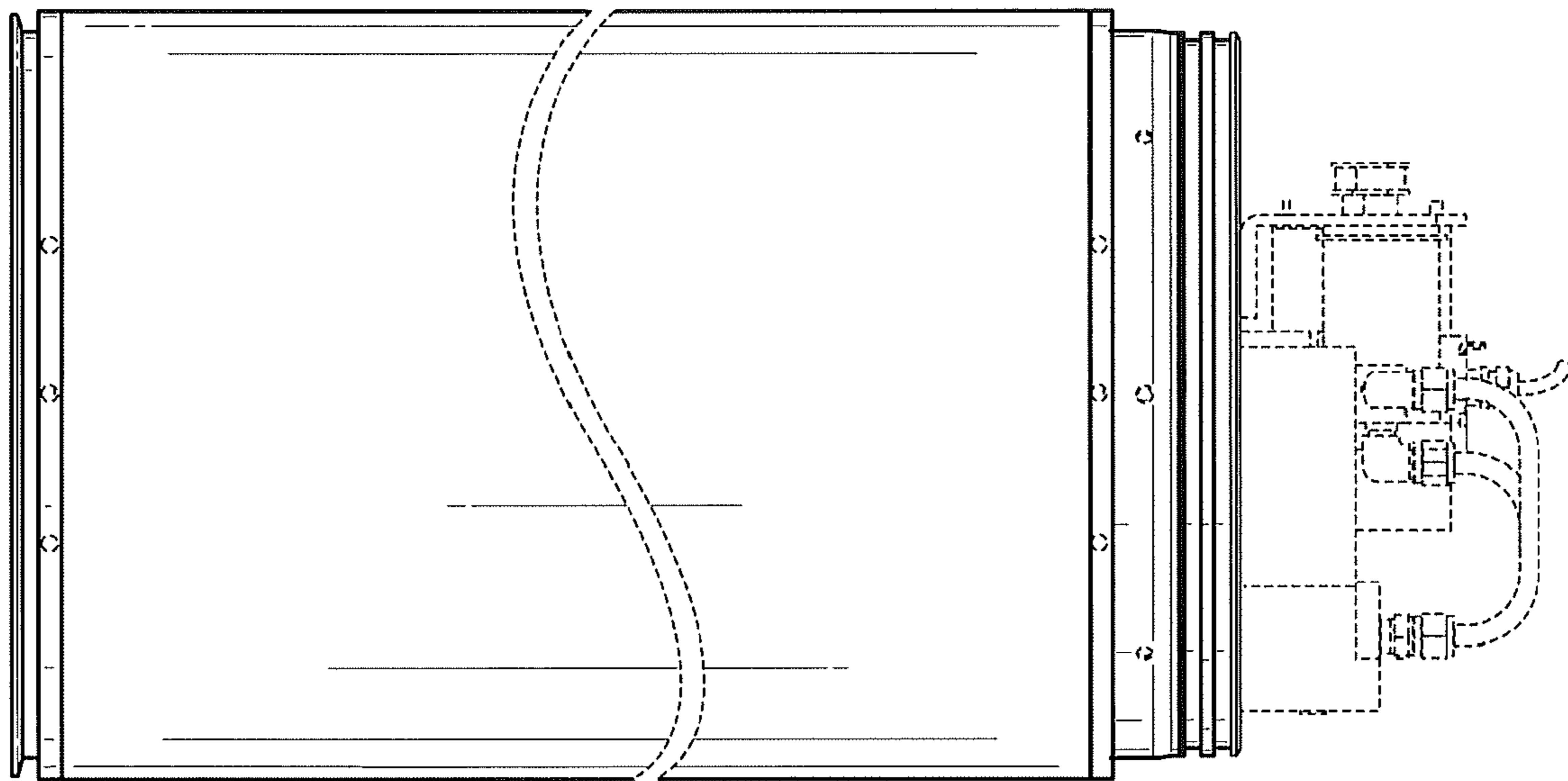

FIG. 12

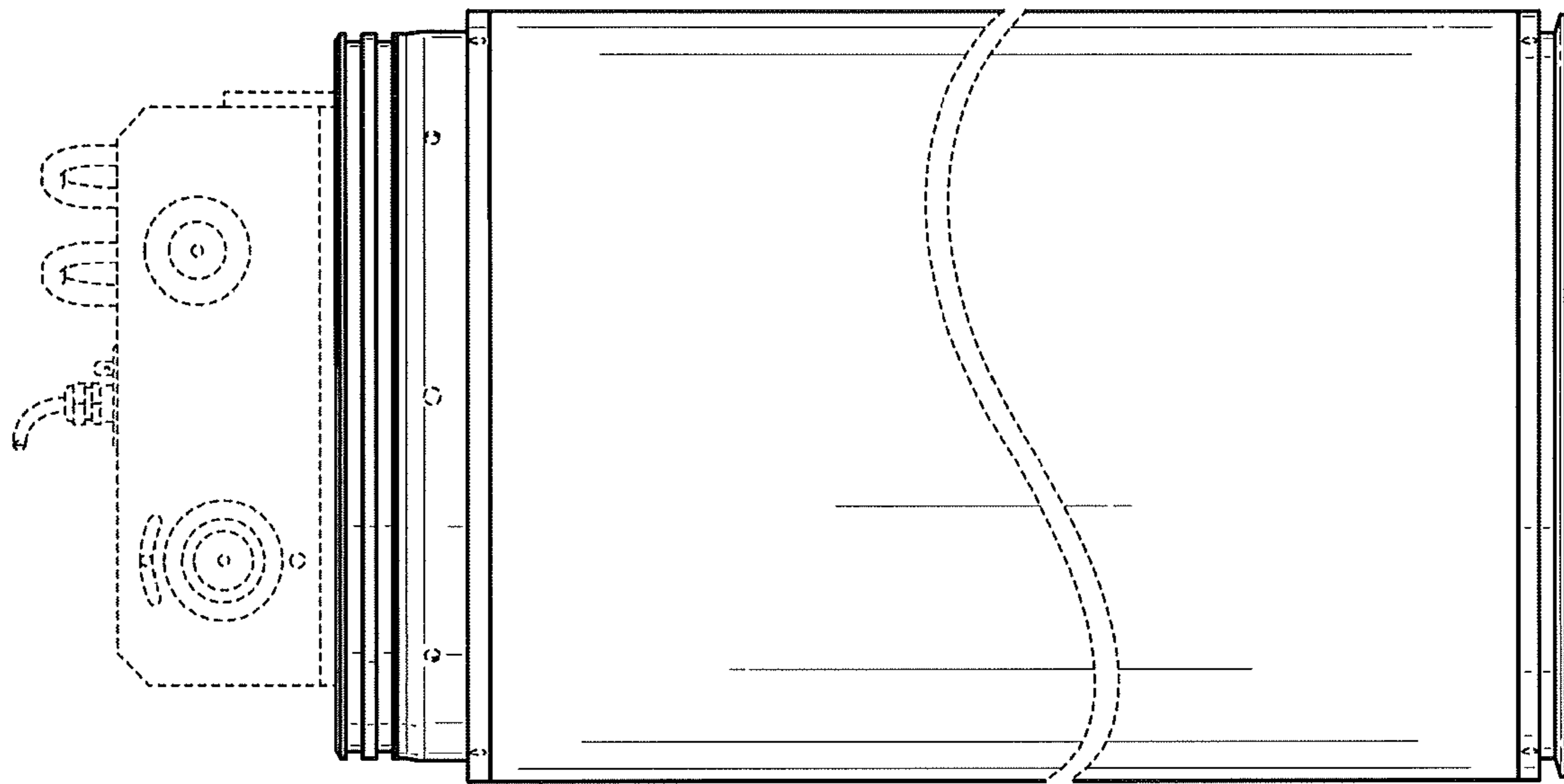

FIG. 13

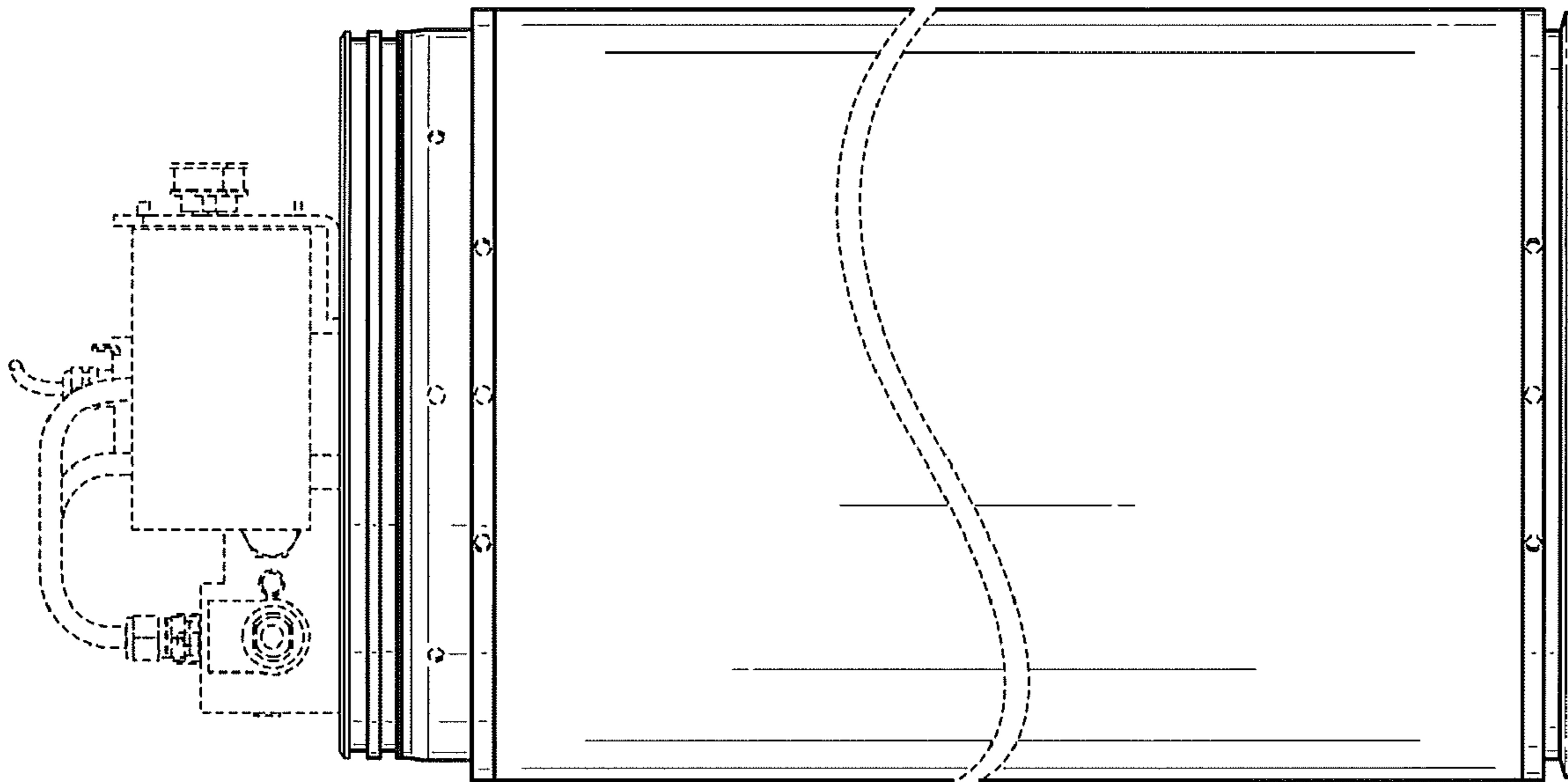

FIG. 14