



US00D649894S

(12) **United States Design Patent**
Daniels et al.

(10) **Patent No.:** **US D649,894 S**
(45) **Date of Patent:** **** Dec. 6, 2011**

(54) **ELECTRONIC TOKEN AND DATA CARRIER**

(75) Inventors: **Dean Daniels**, Rosemount, MN (US);
William Stifle, Rogers, MN (US)

(73) Assignee: **ATEK Products, LLC**, Brainerd, MN
(US)

(**) Term: **14 Years**

(21) Appl. No.: **29/330,181**

(22) Filed: **Dec. 30, 2008**

(51) **LOC (9) Cl.** **10-05**

(52) **U.S. Cl.** **D10/106.9**

(58) **Field of Classification Search** D10/106.9,
D10/106.91; D3/207; D14/299, 436, 480.1-480.7;
235/487-492; 194/205; 361/728-733; D8/347
See application file for complete search history.

(56) **References Cited**

U.S. PATENT DOCUMENTS

D59,194 S	10/1921	Collins
2,057,532 A	10/1936	MacDonald
2,176,253 A	10/1939	Fogarty
2,312,204 A	2/1943	Weindel, Jr.
D140,669 S	3/1945	Moore
D161,490 S	1/1951	Moore
2,540,718 A	2/1951	Duskin
3,001,167 A	9/1961	Chesnutt et al.
3,122,996 A	3/1964	Heatwole
3,222,534 A	12/1965	Scott
3,500,326 A	3/1970	Benford
3,544,769 A	12/1970	Hedin
3,641,315 A	2/1972	Nagata et al.
3,641,498 A	2/1972	Hedin
3,644,745 A	2/1972	Bell
3,648,020 A	3/1972	Tateisi
3,651,464 A	3/1972	Hedin et al.
3,657,496 A	4/1972	Davidson
3,660,831 A	5/1972	Nicola
3,663,774 A	5/1972	Feder
3,673,467 A	6/1972	Eisenreich
3,678,250 A	7/1972	Dethloff et al.
3,686,659 A	8/1972	Bostrom
3,694,810 A	9/1972	Mullens et al.
3,702,464 A	11/1972	Castrucci

3,754,214 A	8/1973	Matsumoto et al.
3,757,305 A	9/1973	Hedin
3,761,892 A	9/1973	Bosnyak
3,782,148 A	1/1974	Goldman
3,806,882 A	4/1974	Clarke
3,842,629 A	10/1974	Pazer et al.
3,848,229 A	11/1974	Perron et al.
3,859,634 A	1/1975	Perron et al.
3,889,501 A	6/1975	Fort
3,928,750 A	12/1975	Wolflingseder
3,971,916 A	7/1976	Moreno
4,023,161 A	5/1977	Sasaki
4,050,063 A	9/1977	Schull
4,085,394 A	4/1978	Weisenburger
4,176,782 A	12/1979	Fukuda et al.
4,211,919 A	7/1980	Ugon
4,225,758 A	9/1980	Konou et al.
4,297,569 A	10/1981	Files
4,317,957 A	3/1982	Sendrow
4,326,125 A	4/1982	Files
D265,049 S	6/1982	Flies
4,333,328 A	6/1982	Platt
4,355,856 A	10/1982	Porter
4,379,966 A	4/1983	Flies
4,420,794 A	12/1983	Anderson
4,432,218 A	2/1984	Hoener
4,436,993 A	3/1984	Files
4,448,466 A	5/1984	Porter
D274,126 S	6/1984	Flies
4,461,525 A	7/1984	Griffin
4,463,218 A	7/1984	Suzuki
4,466,680 A	8/1984	Sakai et al.
D278,836 S	5/1985	Flies
4,522,456 A	6/1985	Wehrmacher
D279,586 S	7/1985	Flies
4,549,076 A	10/1985	Flies
4,572,679 A	2/1986	Dorr
4,578,573 A	3/1986	Flies et al.
4,620,088 A	10/1986	Flies et al.
4,631,943 A	12/1986	Hoener
4,659,915 A	4/1987	Flies
4,663,952 A	5/1987	Gelhard
D291,897 S	9/1987	Files
4,752,679 A	6/1988	Wehrmacher
4,791,257 A	12/1988	Frey et al.
D302,238 S	7/1989	Kopu
4,924,686 A	5/1990	Vonlanthen
4,943,708 A *	7/1990	Simmons et al. 235/492
4,947,662 A	8/1990	Imedio
D321,691 S	11/1991	Brenda et al.
D322,387 S	12/1991	Bailey
5,073,703 A	12/1991	Wehrmacher
5,157,244 A	10/1992	Mroczkowski et al.

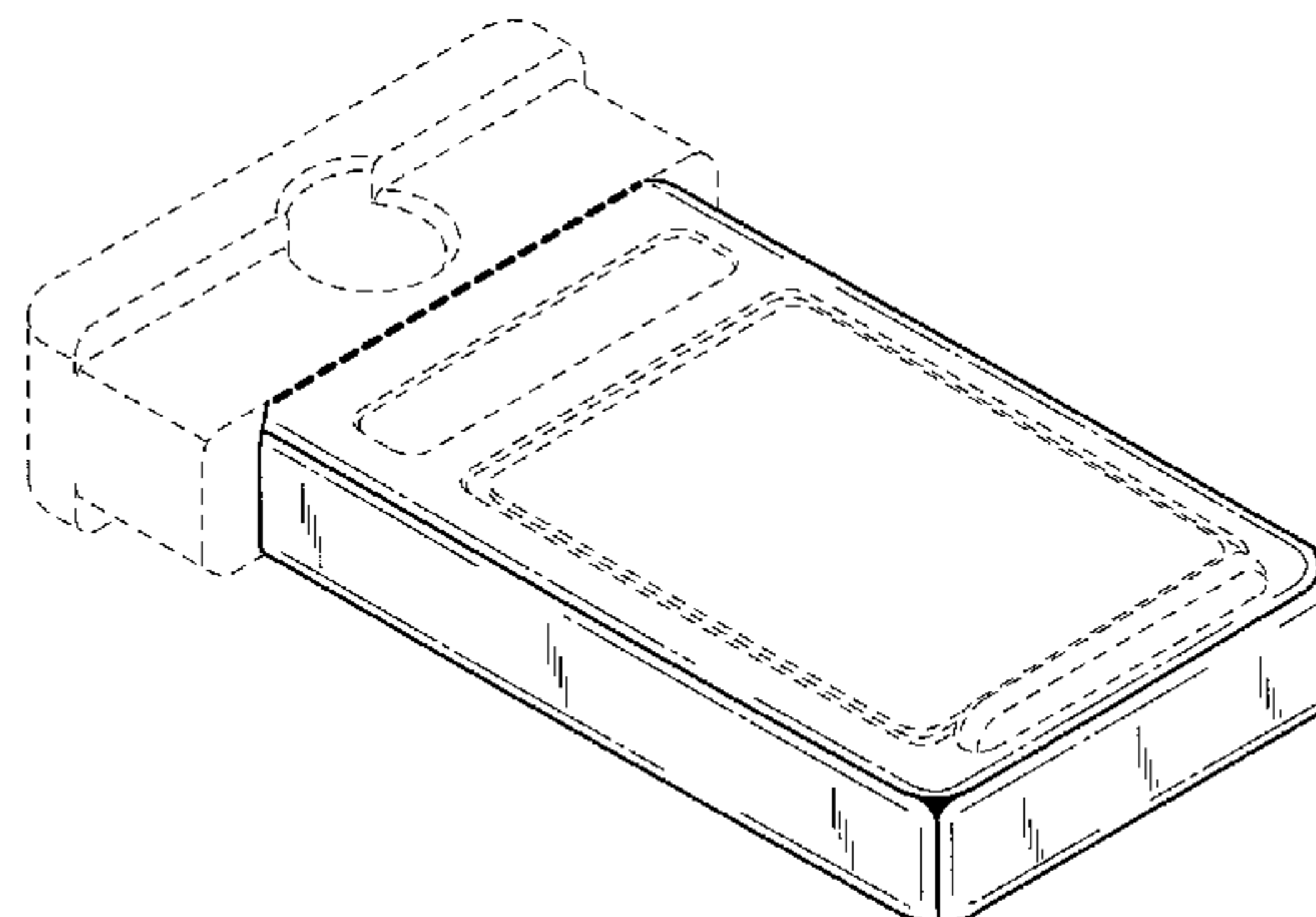
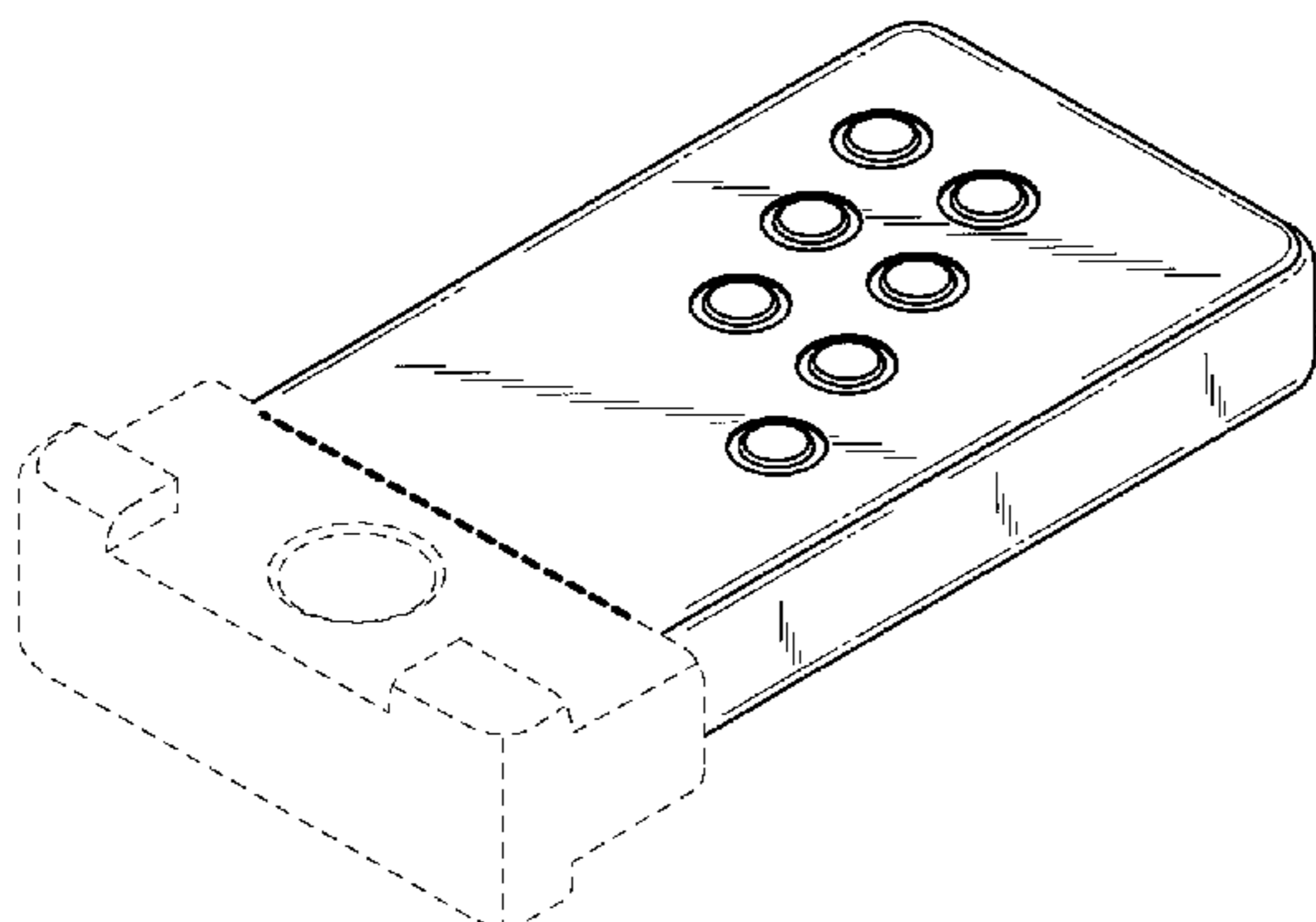

D332,045	S	*	12/1992	Moore	D8/347	
5,186,031	A		2/1993	Janssen et al.			
5,195,341	A		3/1993	Nieuwkoop			
5,204,663	A		4/1993	Lee			
5,109,972	A		6/1993	Van Horn et al.			
5,250,986	A		10/1993	Axten et al.			
D345,686	S		4/1994	Boehner			
5,337,588	A		8/1994	Chhatwal			
5,422,634	A		6/1995	Okubo			
5,432,510	A		7/1995	Matthews			
5,507,162	A		4/1996	Chhatwal			
5,526,662	A		6/1996	Diekoff et al.			
D375,299	S		11/1996	Fekete et al.			
5,625,349	A		4/1997	Disbrow et al.			
5,632,168	A		5/1997	Yano			
5,685,182	A		11/1997	Chhatwal			
D388,722	S	*	1/1998	Wilson	D10/106.1	
5,758,529	A		6/1998	Chhatwal			
5,831,520	A		11/1998	Stephan			
5,831,827	A		11/1998	Fekete et al.			
5,834,747	A		11/1998	Cooper			
5,836,187	A		11/1998	Janssen et al.			
5,841,637	A		11/1998	Chhatwal			
5,923,264	A		7/1999	Lavelle et al.			
5,949,047	A		9/1999	Abe et al.			
6,000,258	A		12/1999	Lesko			
6,035,677	A		3/2000	Janssen et al.			
6,078,265	A		6/2000	Bonder et al.			
6,092,404	A		7/2000	Chhatwal			
6,218,955	B1		4/2001	Conklin			
6,227,019	B1		5/2001	Chhatwal			
6,296,190	B1		10/2001	Rendleman			
6,354,122	B1		3/2002	Snoke			
6,384,709	B2		5/2002	Mellen et al.			
D460,012	S	*	7/2002	Proulx et al.	D10/106.9	
6,414,586	B1		7/2002	Yoshizawa			
6,425,084	B1		7/2002	Rallis et al.			
6,486,793	B1		11/2002	Buccola			
6,604,087	B1		8/2003	Kolls			
D502,418	S	*	3/2005	Copen	D10/106.9	
D512,060	S		11/2005	Wang et al.			
D518,030	S		3/2006	Lin			
D519,099	S	*	4/2006	Liu et al.	D14/155	
7,109,863	B2	*	9/2006	Morrison	340/568.1	
D532,783	S		11/2006	Yu			
D534,414	S		1/2007	Stifle et al.			
7,158,008	B2		1/2007	Warning			
D540,749	S	*	4/2007	Kaule	D13/168	
D551,215	S	*	9/2007	Lee et al.	D14/218	
D552,613	S	*	10/2007	Tan	D14/436	
D557,588	S		12/2007	Stifle et al.			
D559,249	S		1/2008	Takei et al.			
7,407,390	B1		8/2008	Ni			
D587,719	S	*	3/2009	Tate et al.	D14/480.1	
D594,871	S		6/2009	Ma			
D599,795	S		9/2009	Lindley			
7,597,250	B2		10/2009	Finn			
D603,601	S	*	11/2009	Ohta et al.	D3/207	
D626,022	S	*	10/2010	Sayegh et al.	D10/106.91	
D626,963	S		11/2010	Kim			
2002/0025062	A1		2/2002	Black			
2003/0184432	A1		10/2003	Waring et al.			
2003/0195585	A1		10/2003	Gruzdowich et al.			
2006/0186990	A1		8/2006	Yamamoto et al.			
2006/0219776	A1		10/2006	Finn			
2006/0246784	A1		11/2006	Aekins et al.			
2008/0074235	A1		3/2008	Wong et al.			
2008/0304712	A1		12/2008	Rowe et al.			
2010/0193583	A1		8/2010	Tartavull et al.			

FOREIGN PATENT DOCUMENTS

DE	10 60 961	7/1959
DE	36 20 755	12/1987
DE	43 30 017	3/1995
EP	0 367 433 A1	5/1990
EP	0 793 188	9/1997
EP	1 213 417	6/2002
FR	1 321 529	2/1962
FR	2 146 802	3/1973

FR	2363837	3/1978
FR	2 654 556	5/1991
FR	2 723 655	2/1996
FR	2 775 373	8/1999
GB	1 427 825	3/1973
GB	2 073 808	10/1981
SU	639056	12/1978
WO	WO 83/00976	3/1983
WO	WO 98/034218	8/1998
WO	WO 01/42598	6/2001
WO	WO 02/09311	1/2002
WO	WO 2009/012495	1/2009
WO	2009/029864 A1	3/2009
WO	2010/088556 A1	8/2010

OTHER PUBLICATIONS

Lubachevsky, Boris D. et al. "Dense Packings of Congruent Circles in Rectangles with a Variable Aspect Ratio," arXiv:math/0405148 (May 2004).

Lubachevsky, Boris D. et al. "Minimum Perimeter Rectangles That Enclose Congruent Non-Overlapping Circles," *Discrete Mathematics*, vol. 309, pp. 1947-1962 (2009).

Weisstein, Eric W. "Circle Packing," *MathWorld*—A Wolfram Web Resource, <http://mathworld.wolfram.com/CirclePacking.html>. [Retrieved on Jul. 9, 2011.] Retrieved from the Internet: <URL: <http://mathworld.wolfram.com/CirclePacking.html>>.

Supplemental European Search Report dated May 27, 2011, for corresponding EP Application No. 08782145.0.

Advanced Portable Information Products, *Datakey Brochure*, 1999.

DataTic™ *Datakey Brochure*, 2000.

"2KBIT Read/Write with Anticollision Contactless Identification Device EM4056", *EM Microelectronic-Marin SA*, Informational Brochure, 13 pgs., 2001.

"Read Only Contactless Identification Device H4102", Swatch Group, 6 pgs., 2000.

"Read/Write Transponder Device Family", ATMEL Wireless & μC, 2 pgs., 2001.

"Read/Write IDIC Micromodule with 1 Kbit Memory T5552", ATMEL Wireless & μC, 12 pgs., May 1, 2001.

"Standard R/W/IDIC with Integrated Capacitance T554", ATMEL Wireless & μC, 19 pgs., Sep. 3, 2001.

"Multifunctional 330-bit Read/Write RF-Identification IC T557", ATMEL, 24 pgs., Dec. 11, 2001.

iDTAG, Gang Programmer for Datakey Key/Slim Modules (SPI, Microwire & IIC Bus), 6 pgs., Nov. 29, 2001.

DataKey Guardian "Marina Access Control", *Datakey Brochure*, (2 pgs.), Mar. 29, 2002.

DataKey QuikPay, *DataKey Brochure* (2 pgs.), Mar. 29, 2002.

Philps. Appendix RF Manual 6th Edition, document order No. 9397 750 15125, May 2005.

* cited by examiner

Primary Examiner — Caron D Veynar
 Assistant Examiner — George D Kirschbaum
 (74) Attorney, Agent, or Firm — Dorsey & Whitney LLP

(57) CLAIM

The ornamental design for an electronic token and data carrier, as shown.

DESCRIPTION

FIG. 1 is a top perspective view of an electronic token and data carrier according to an embodiment of the present disclosure;
 FIG. 2 is a bottom perspective view thereof;
 FIG. 3 is a top view thereof;
 FIG. 4 is a bottom view thereof;
 FIG. 5 is a side view thereof;
 FIG. 6 is a rear end view thereof;

FIG. 7 is a front end view thereof;
FIG. 8 is a top perspective view of an electronic token and data carrier according to a second embodiment of the present disclosure;
FIG. 9 is a bottom perspective view thereof;
FIG. 10 is a top view thereof;
FIG. 11 is a bottom view thereof;
FIG. 12 is a side view thereof;
FIG. 13 is a rear end view thereof;
FIG. 14 is a front end view thereof;
FIG. 15 is a top perspective view of an electronic token and data carrier according to a third embodiment of the present disclosure;
FIG. 16 is a bottom perspective view thereof;
FIG. 17 is a top view thereof;
FIG. 18 is a bottom view thereof;
FIG. 19 is a side view thereof;
FIG. 20 is a rear end view thereof;
FIG. 21 is a front end view thereof;
FIG. 22 is a top perspective view of an electronic token and data carrier according to a fourth embodiment of the present disclosure;
FIG. 23 is a bottom perspective view thereof;
FIG. 24 is a top view thereof;
FIG. 25 is a bottom view thereof;
FIG. 26 is a side view thereof;
FIG. 27 is a rear end view thereof;
FIG. 28 is a front end view thereof;

FIG. 29 is a top perspective view of an electronic token and data carrier according to a fifth embodiment of the present disclosure;
FIG. 30 is a bottom perspective view thereof;
FIG. 31 is a top view thereof;
FIG. 32 is a bottom view thereof;
FIG. 33 is a side view thereof;
FIG. 34 is a rear end view thereof;
FIG. 35 is a front end view thereof;
FIG. 36 is a top perspective view of an electronic token and data carrier according to a sixth embodiment of the present disclosure;
FIG. 37 is a bottom perspective view thereof;
FIG. 38 is a top view thereof;
FIG. 39 is a bottom view thereof;
FIG. 40 is a side view thereof;
FIG. 41 is a rear end view thereof;
FIG. 42 is a front end view thereof;
FIG. 43 is a top perspective view of an electronic token and data carrier according to a seventh embodiment of the present disclosure;
FIG. 44 is a bottom perspective view thereof;
FIG. 45 is a top view thereof;
FIG. 46 is a bottom view thereof;
FIG. 47 is a side view thereof;
FIG. 48 is a rear end view thereof; and,
FIG. 49 is a front end view thereof.
In the drawings, the broken line showing depicts environmental subject matter and forms no part of the claim.

1 Claim, 21 Drawing Sheets

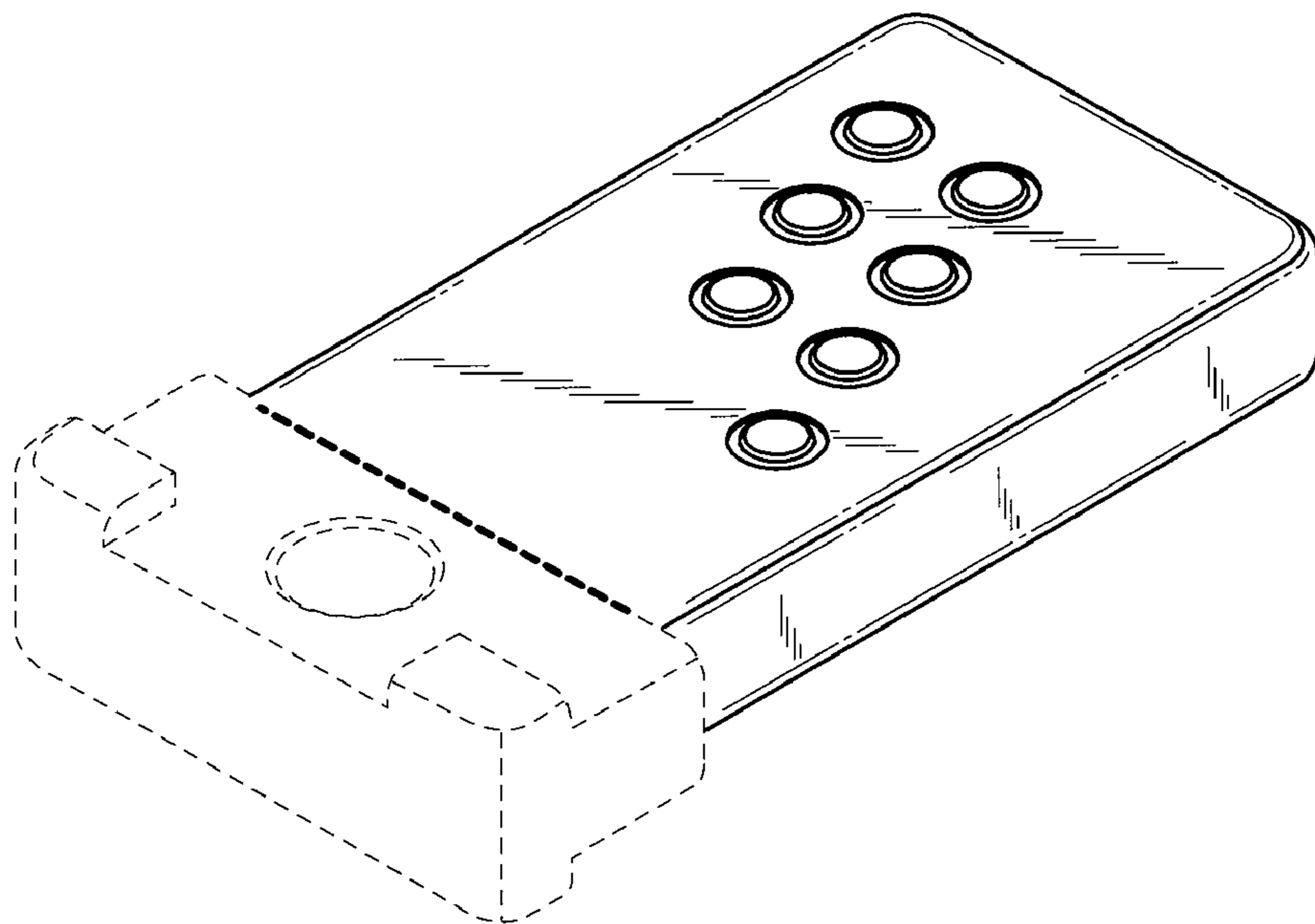

Fig. 1

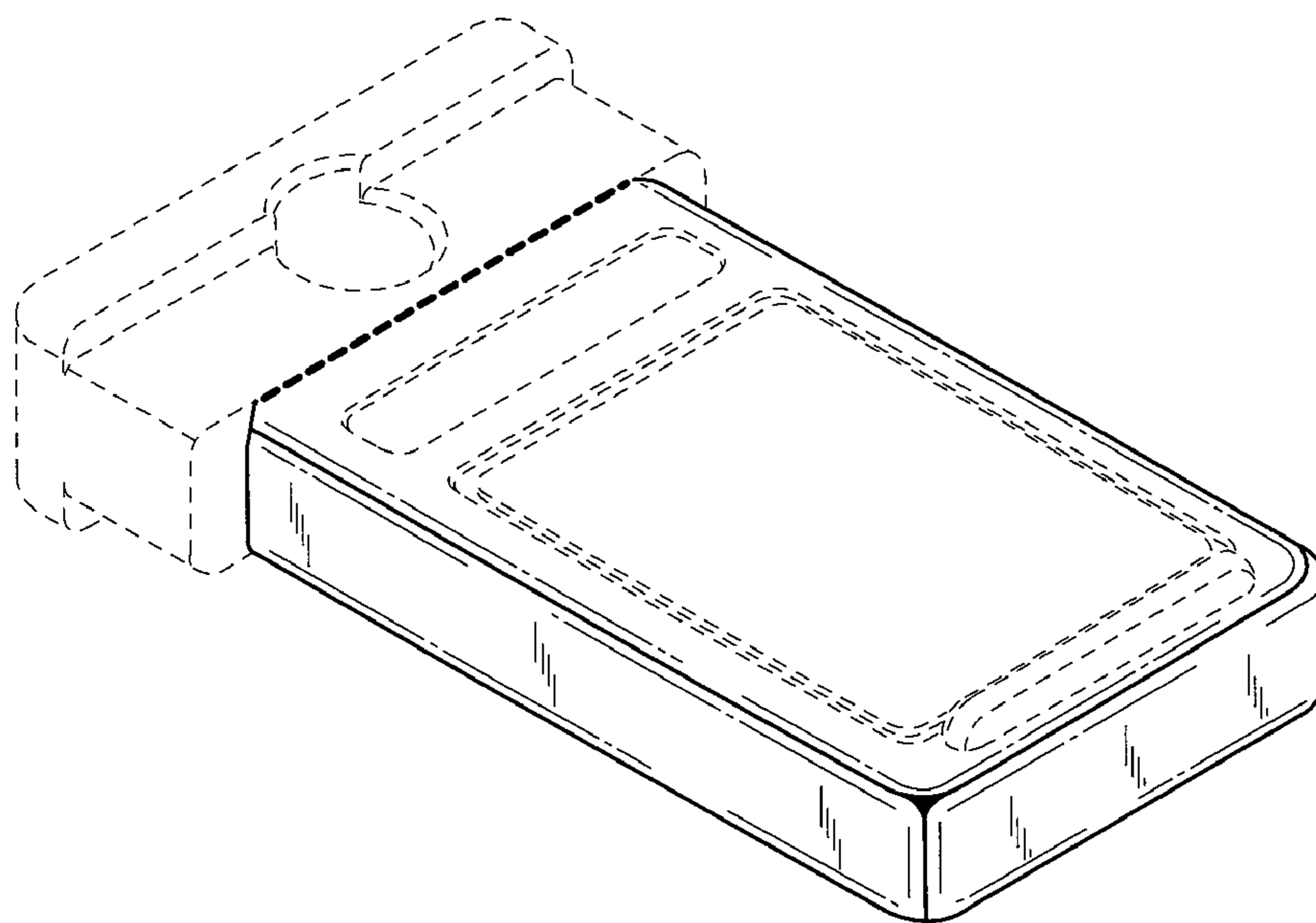

Fig. 2

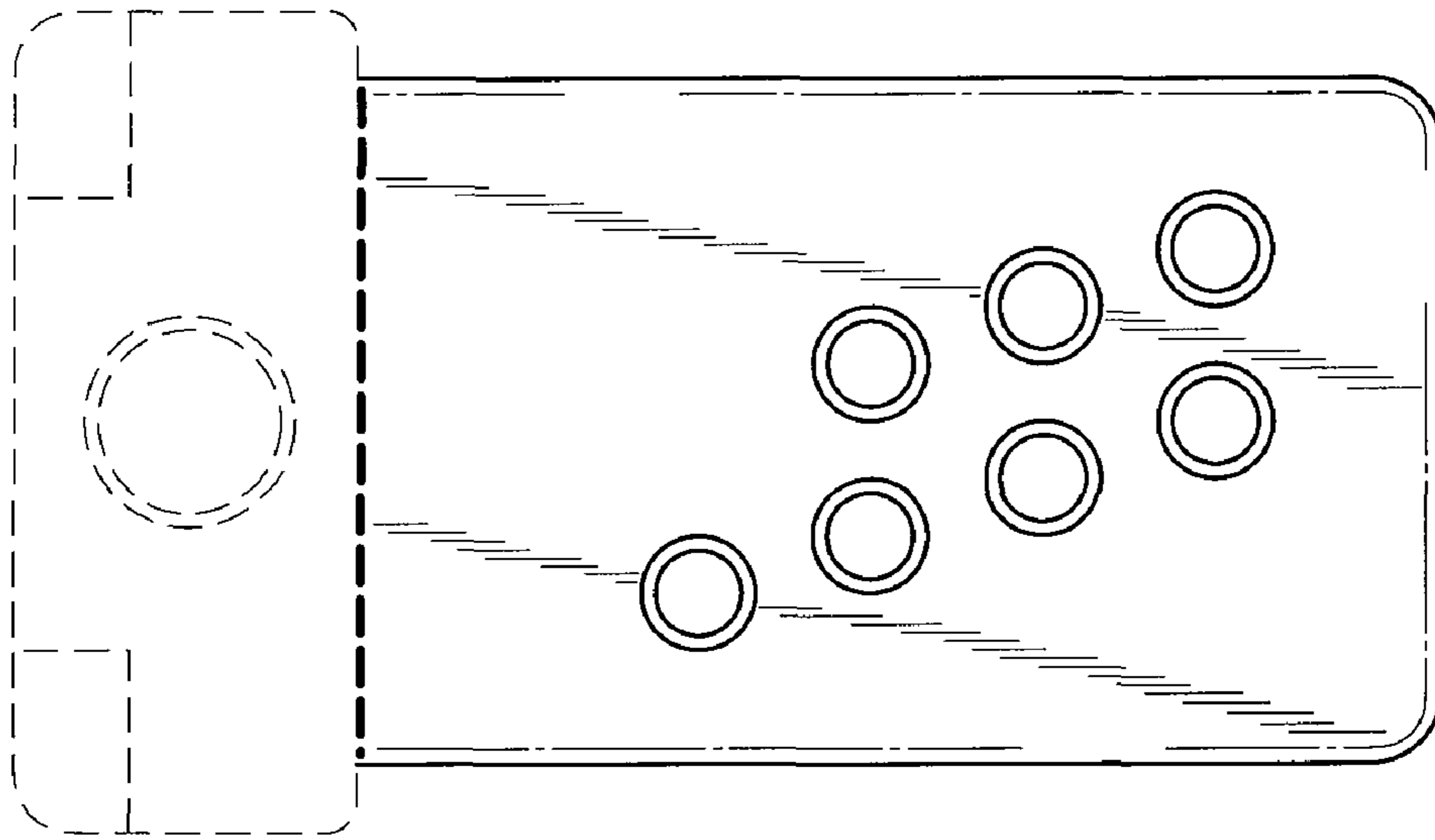

Fig. 3

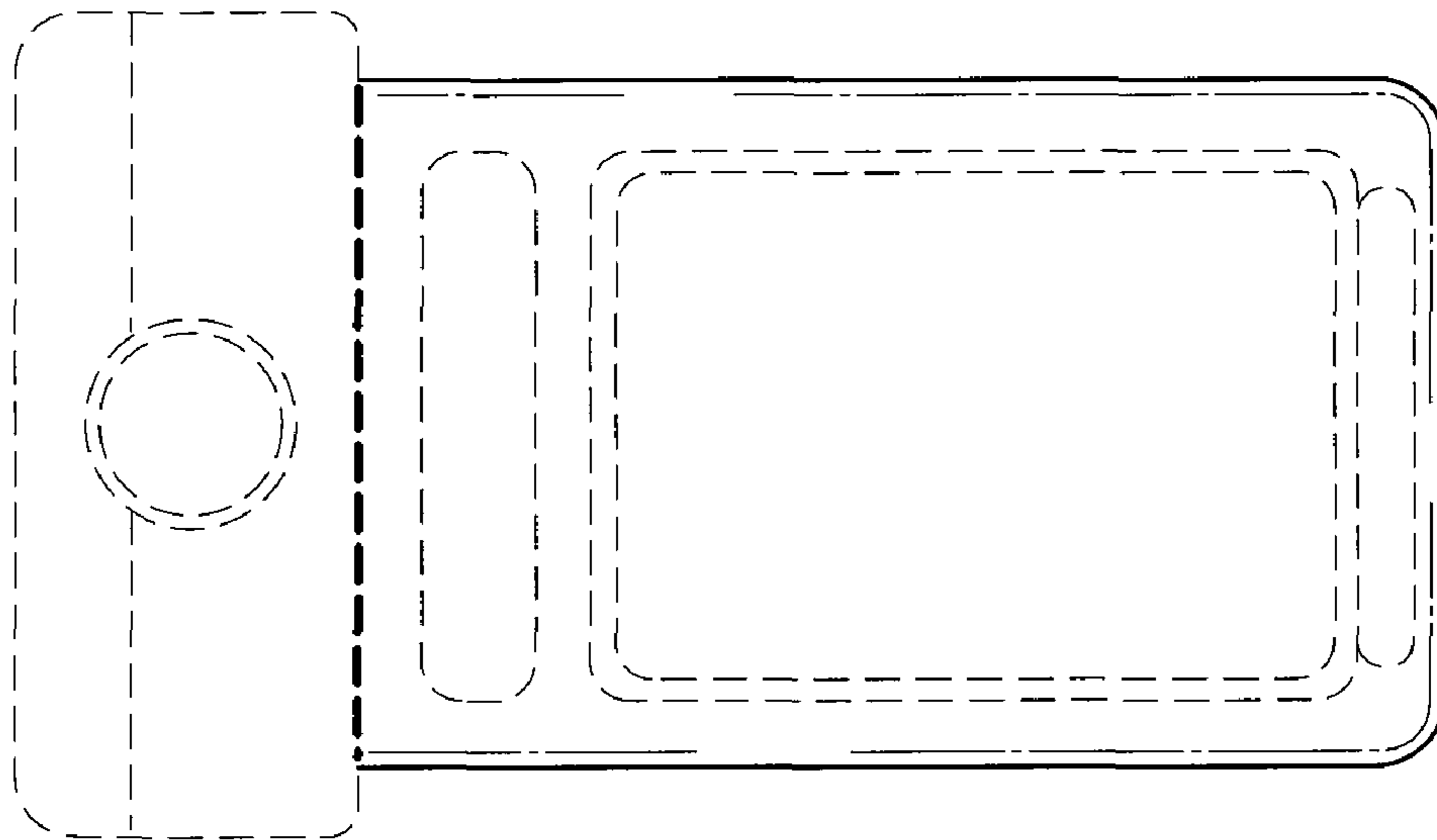

Fig. 4

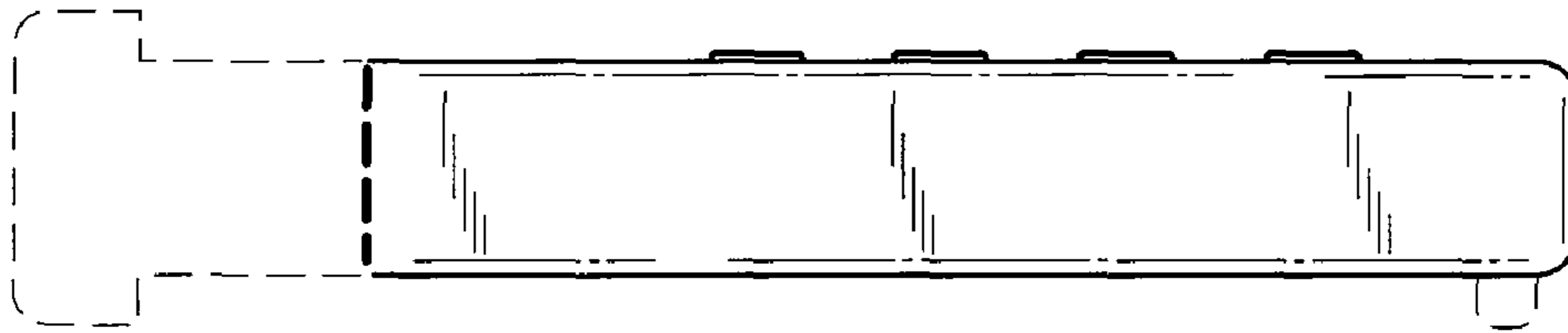

Fig. 5

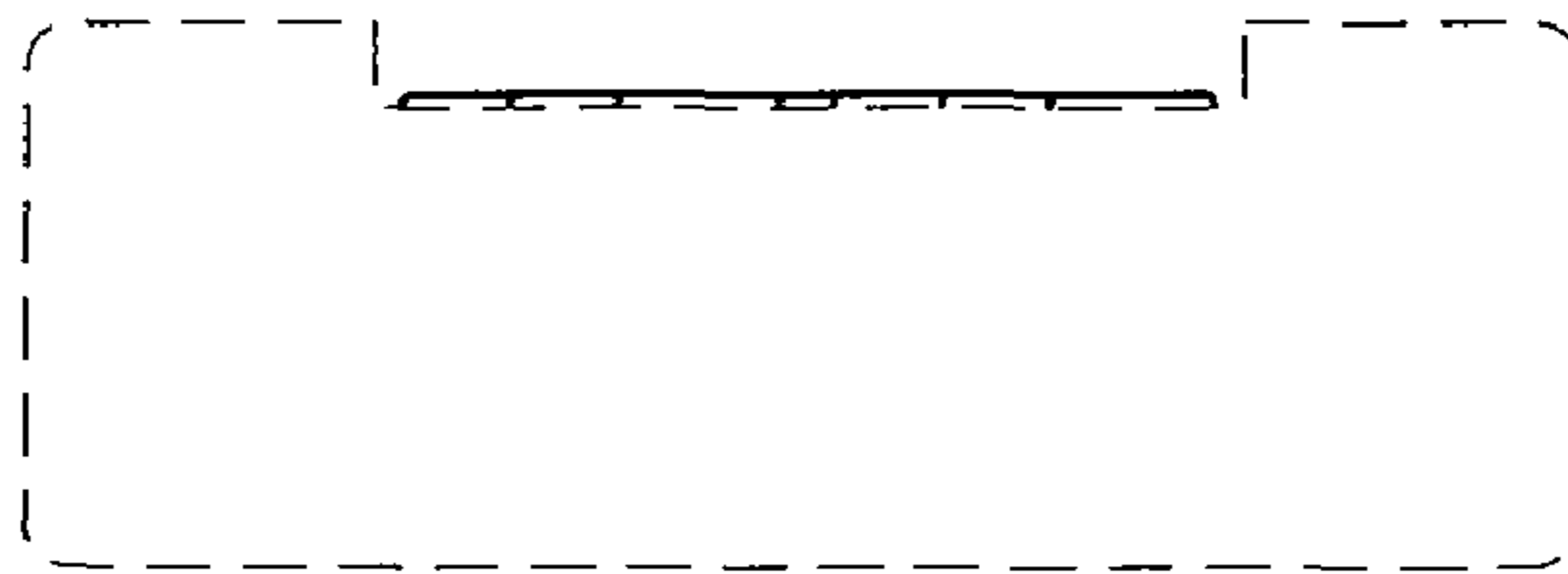

Fig. 6



Fig. 7

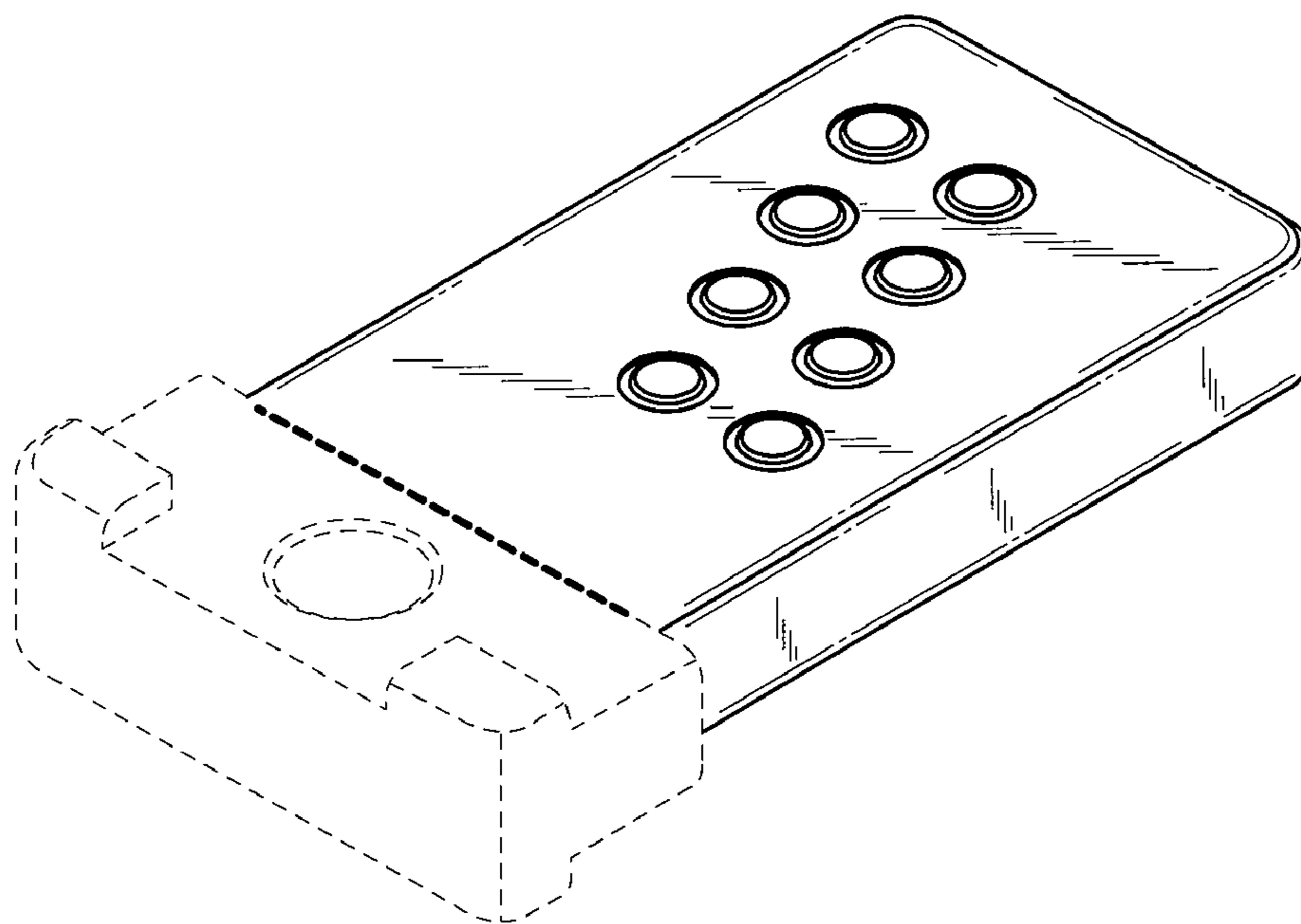

Fig. 8

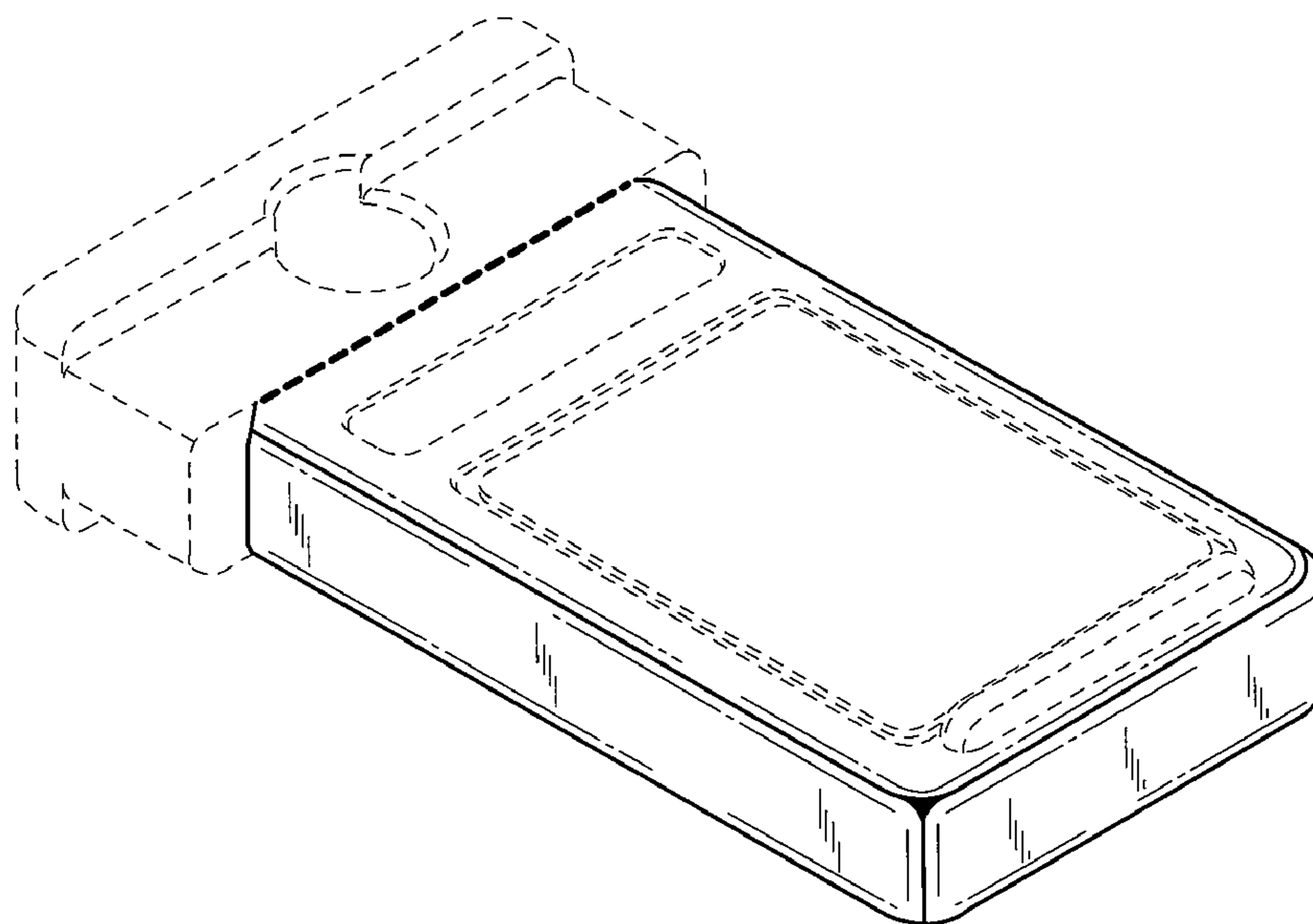

Fig. 9

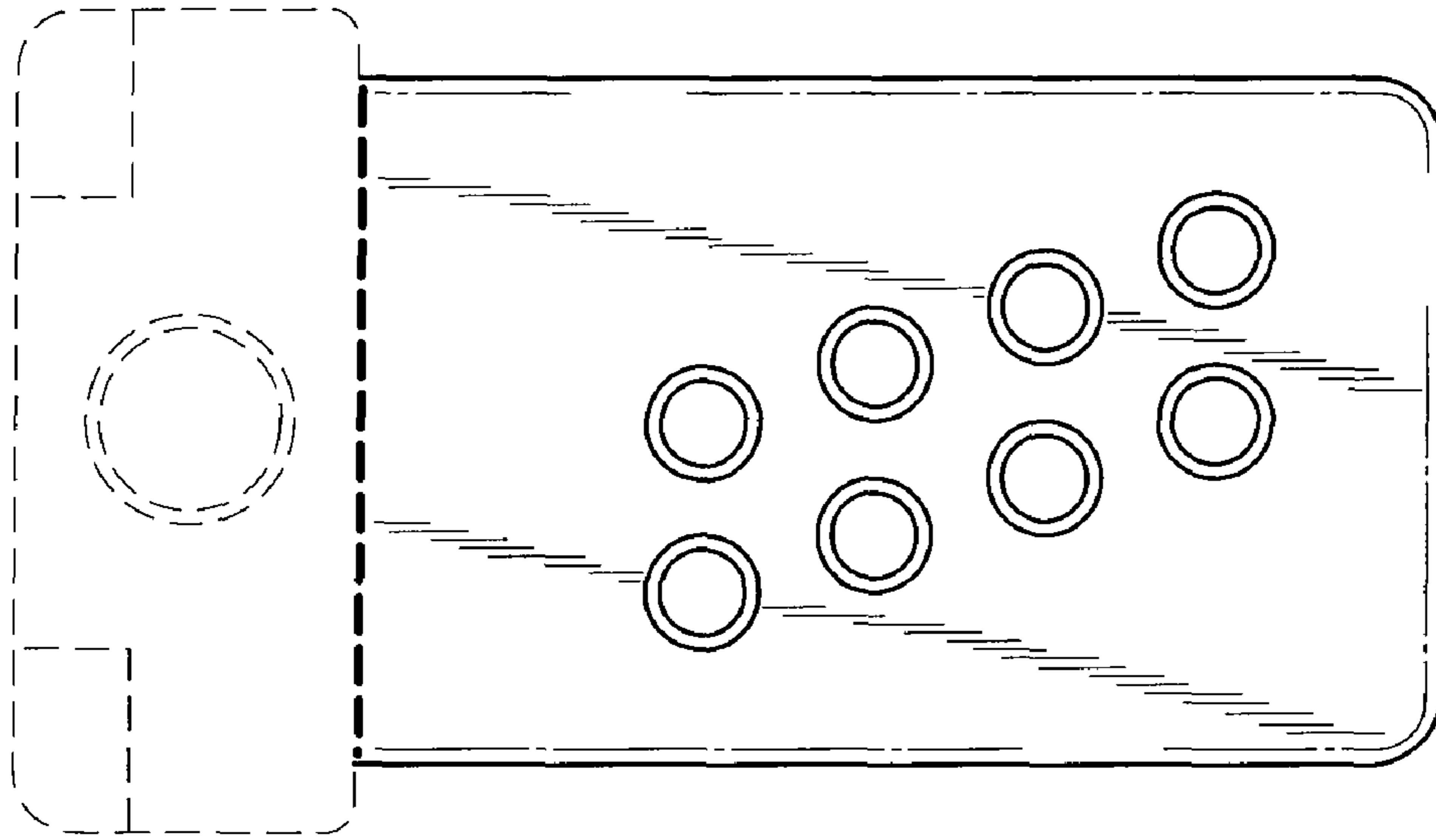

Fig. 10

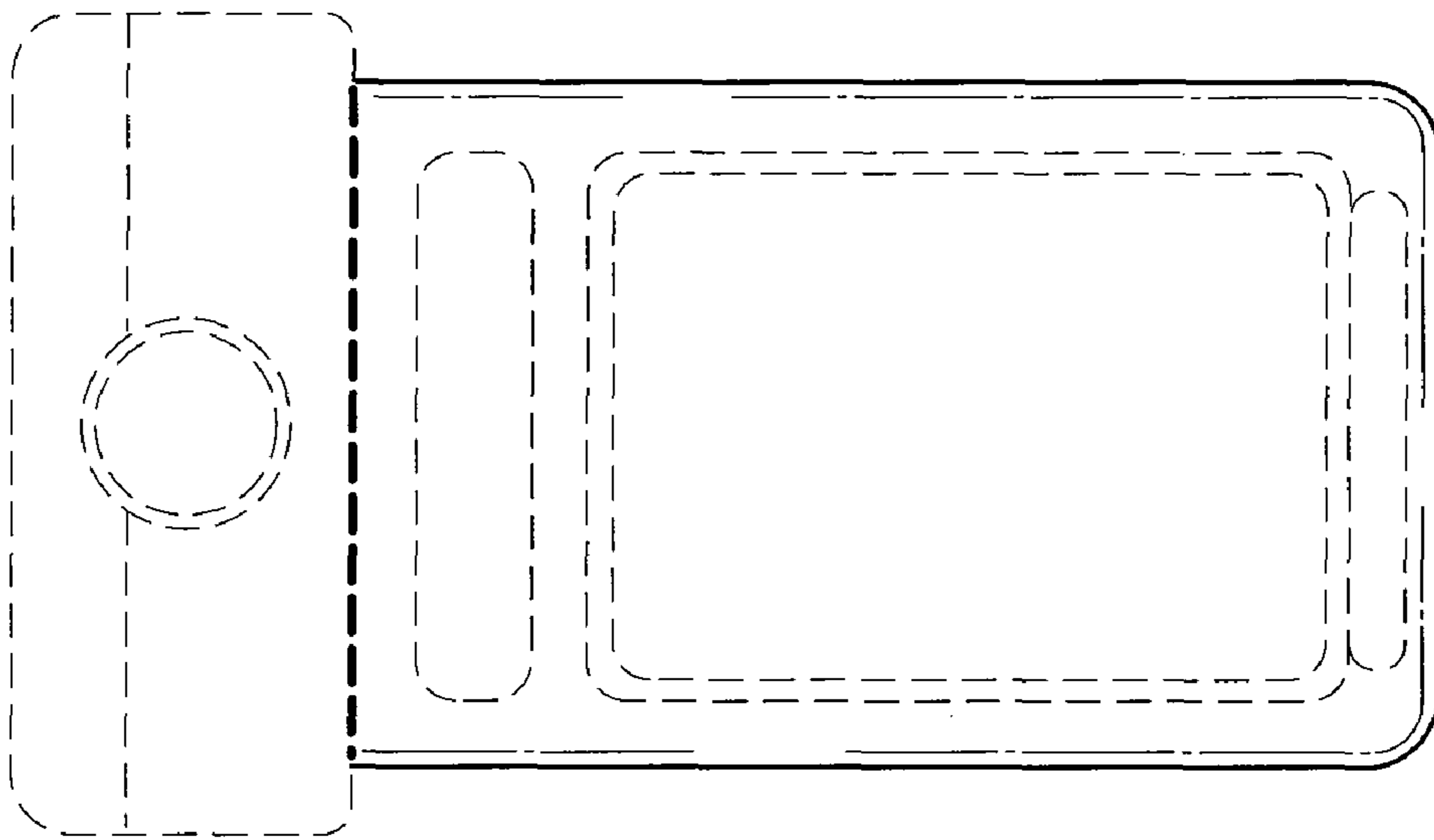

Fig. 11

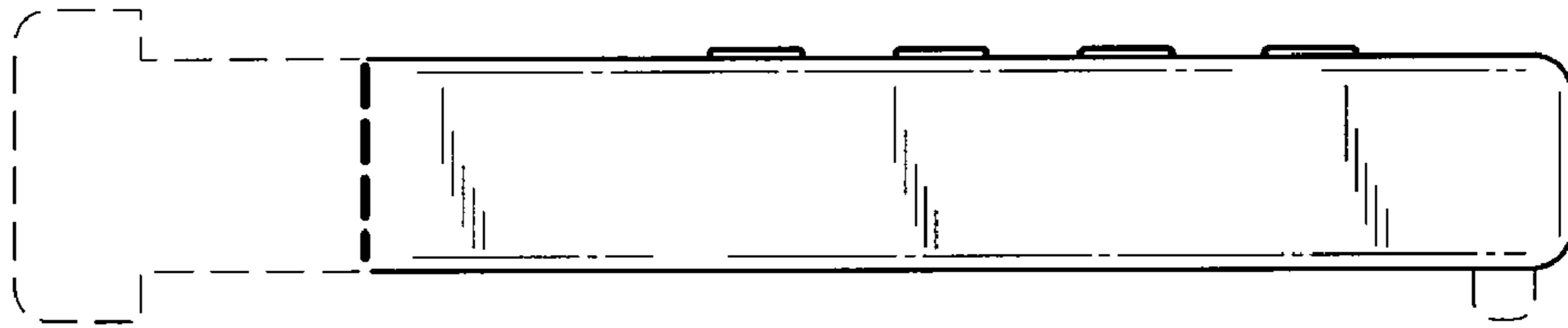

Fig. 12

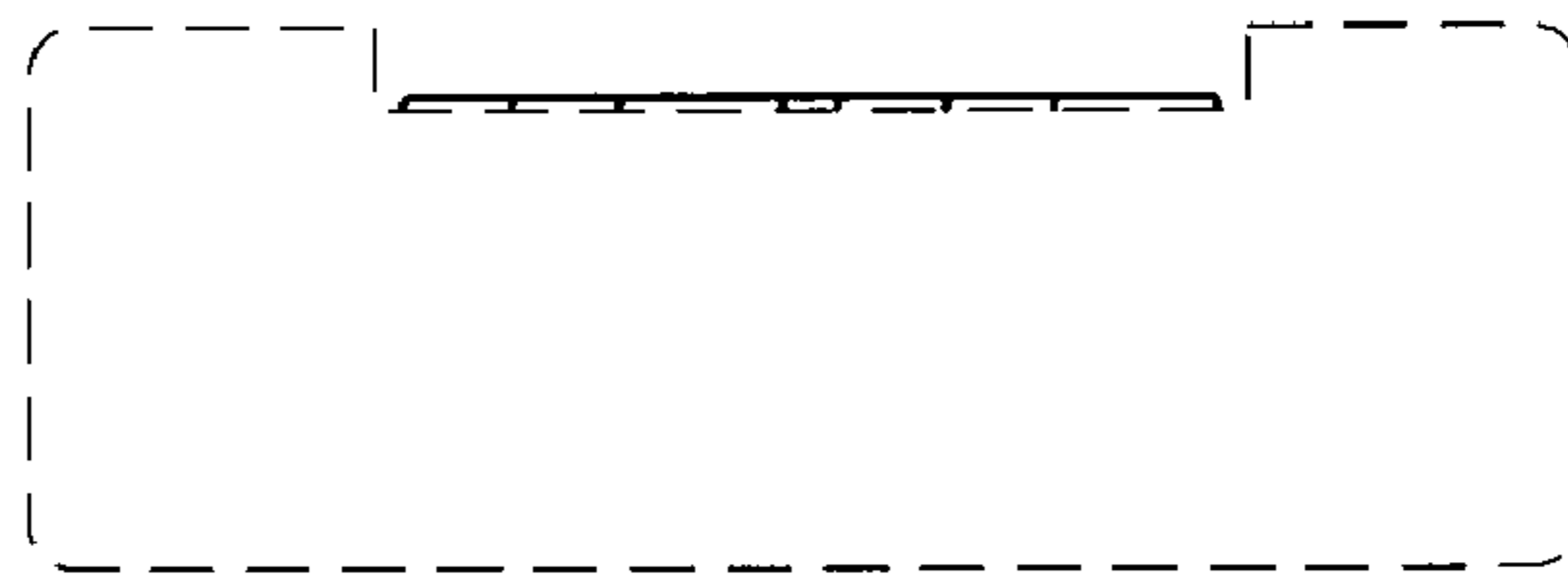

Fig. 13

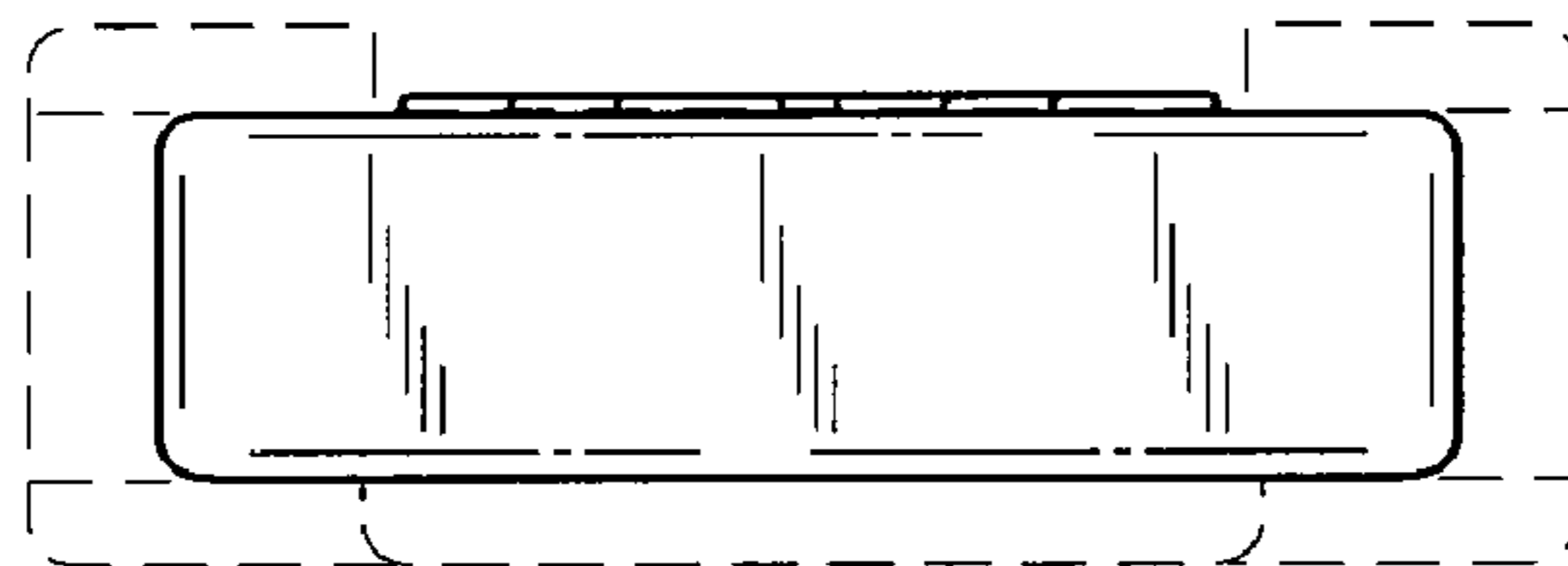

Fig. 14

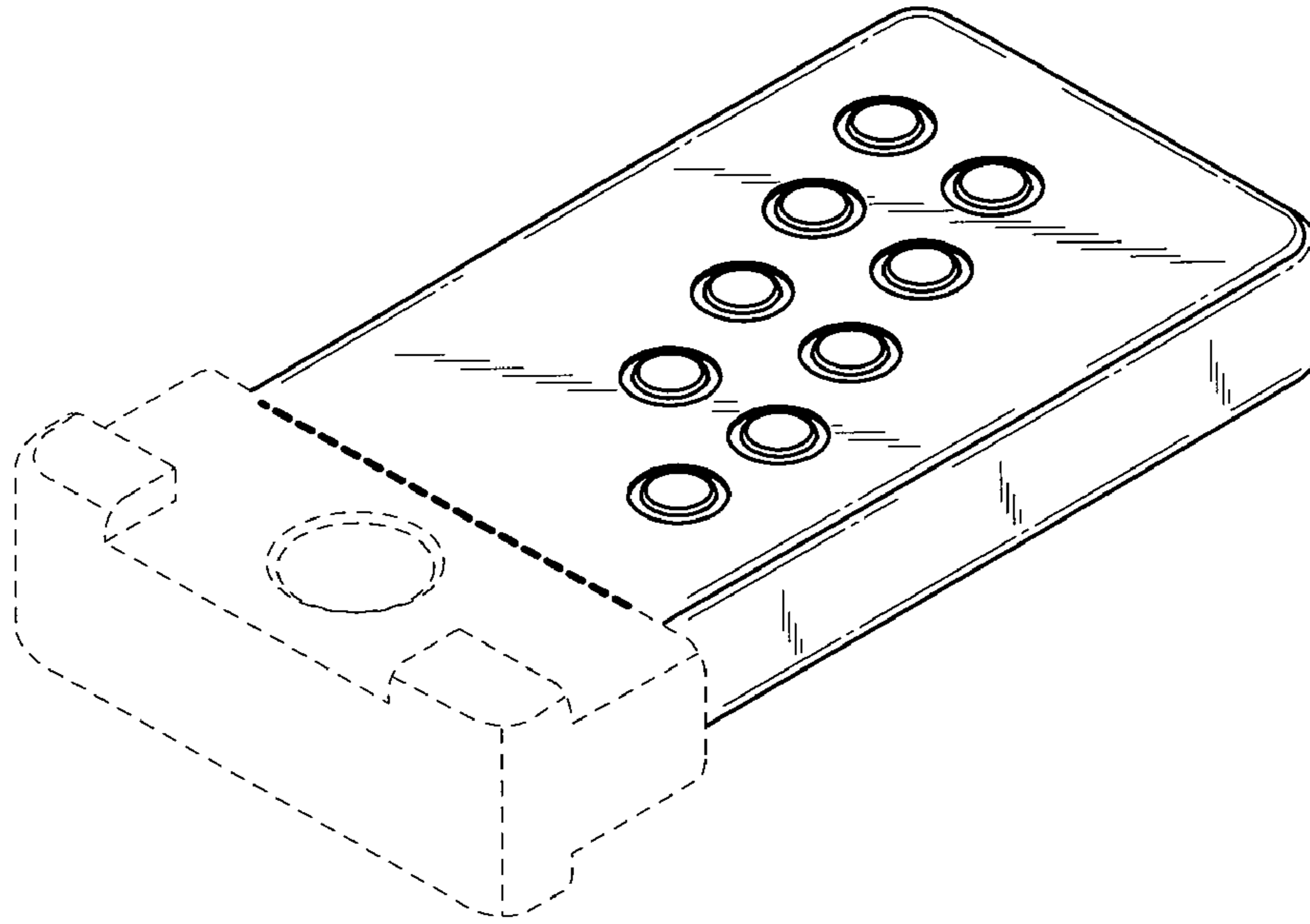

Fig. 15

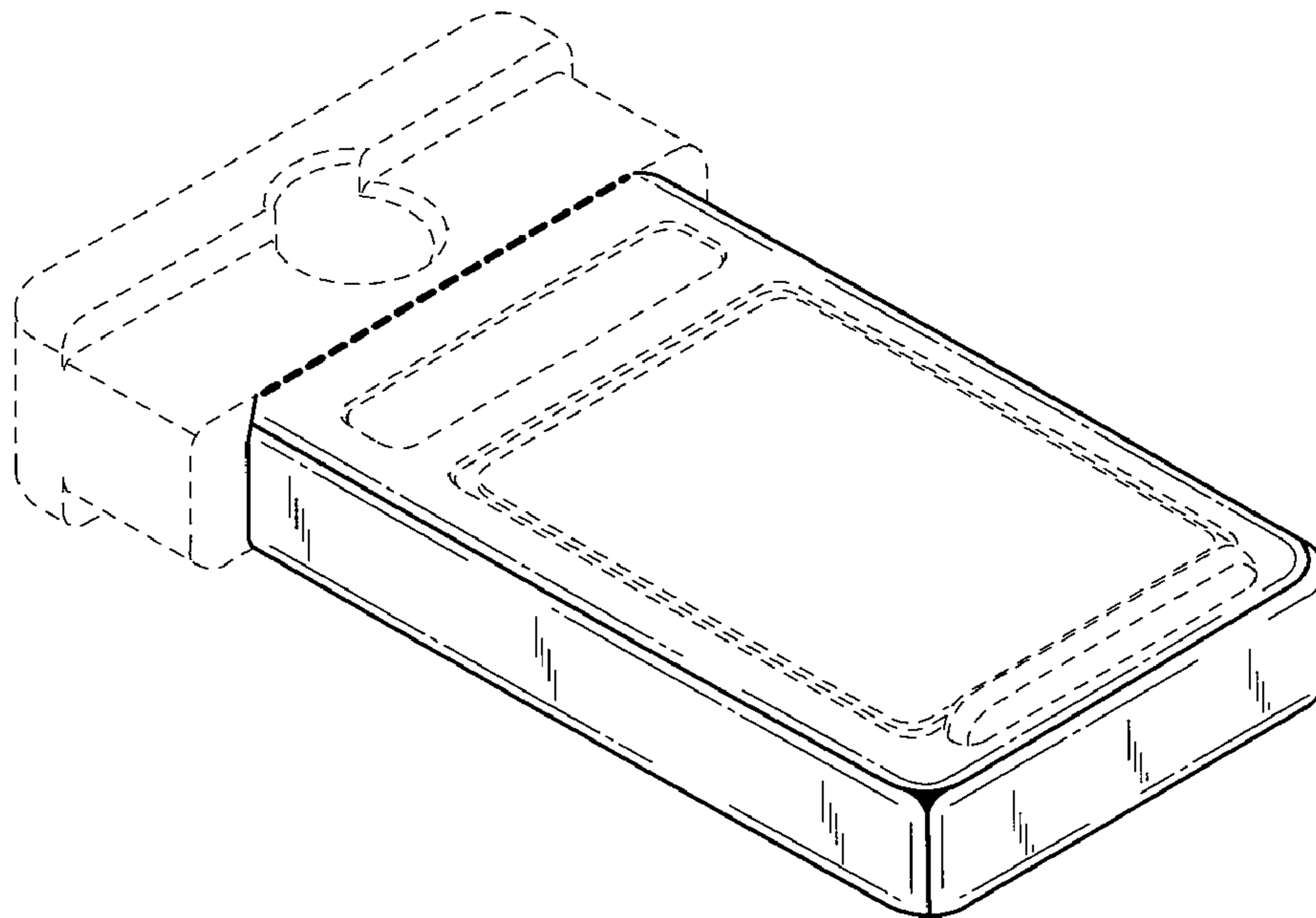

Fig. 16

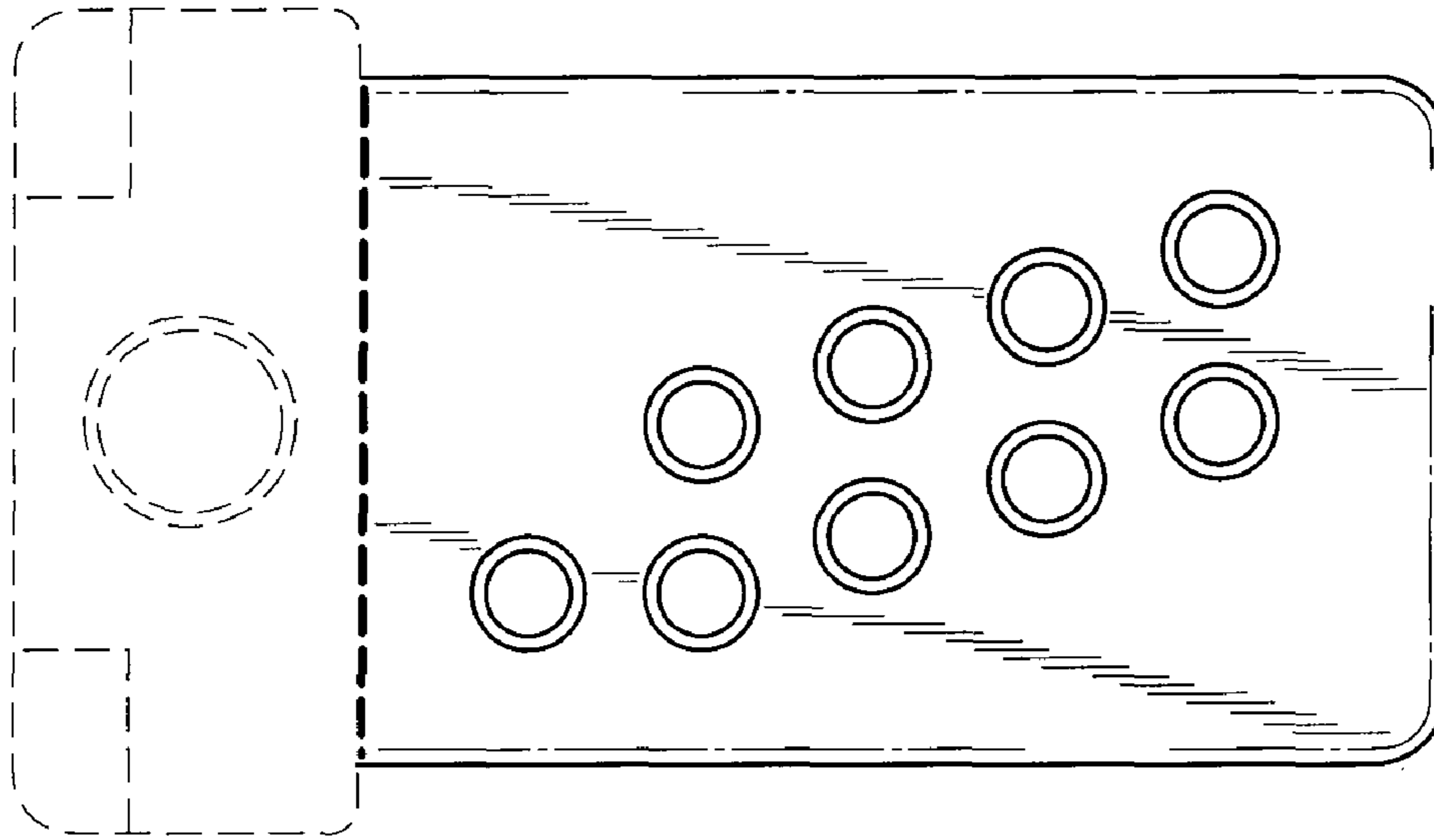

Fig. 17

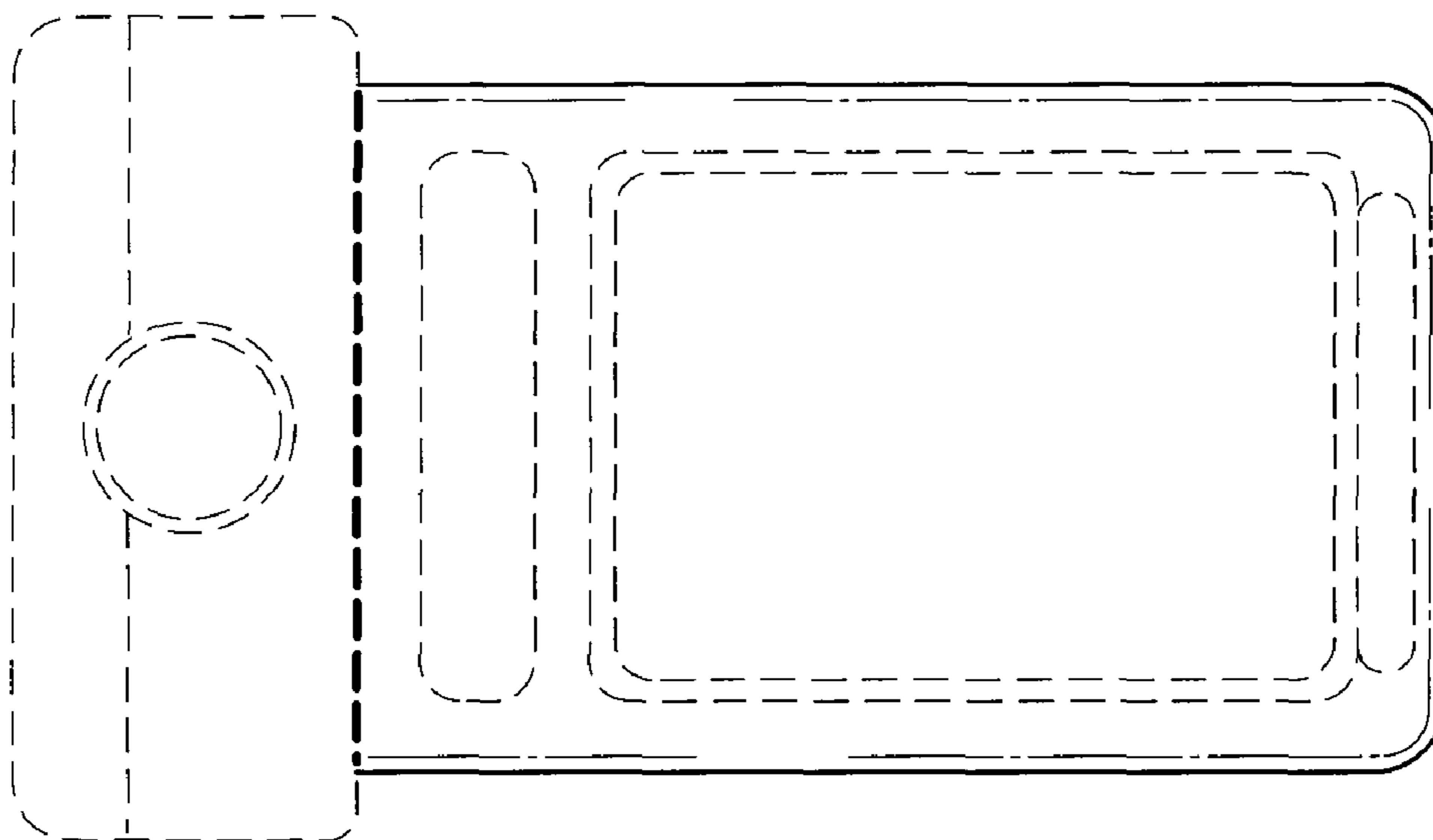

Fig. 18

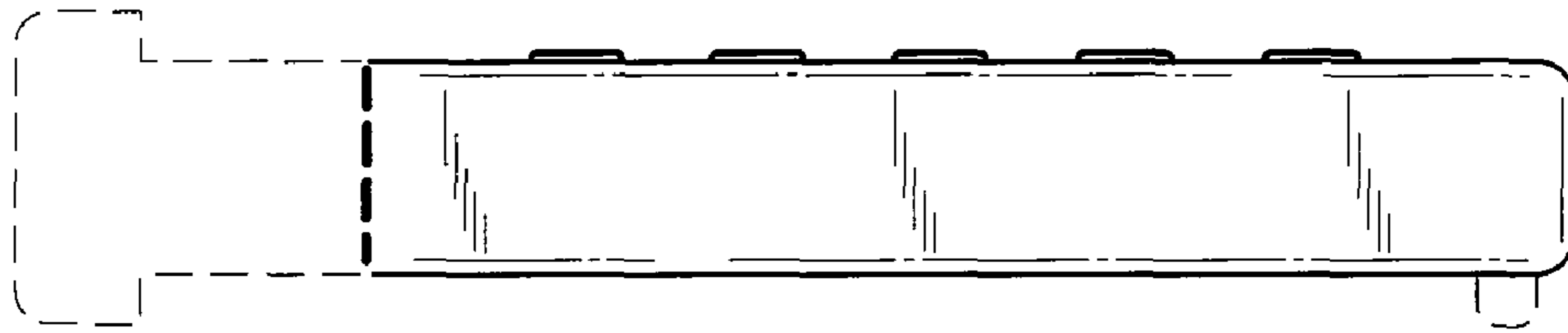

Fig. 19

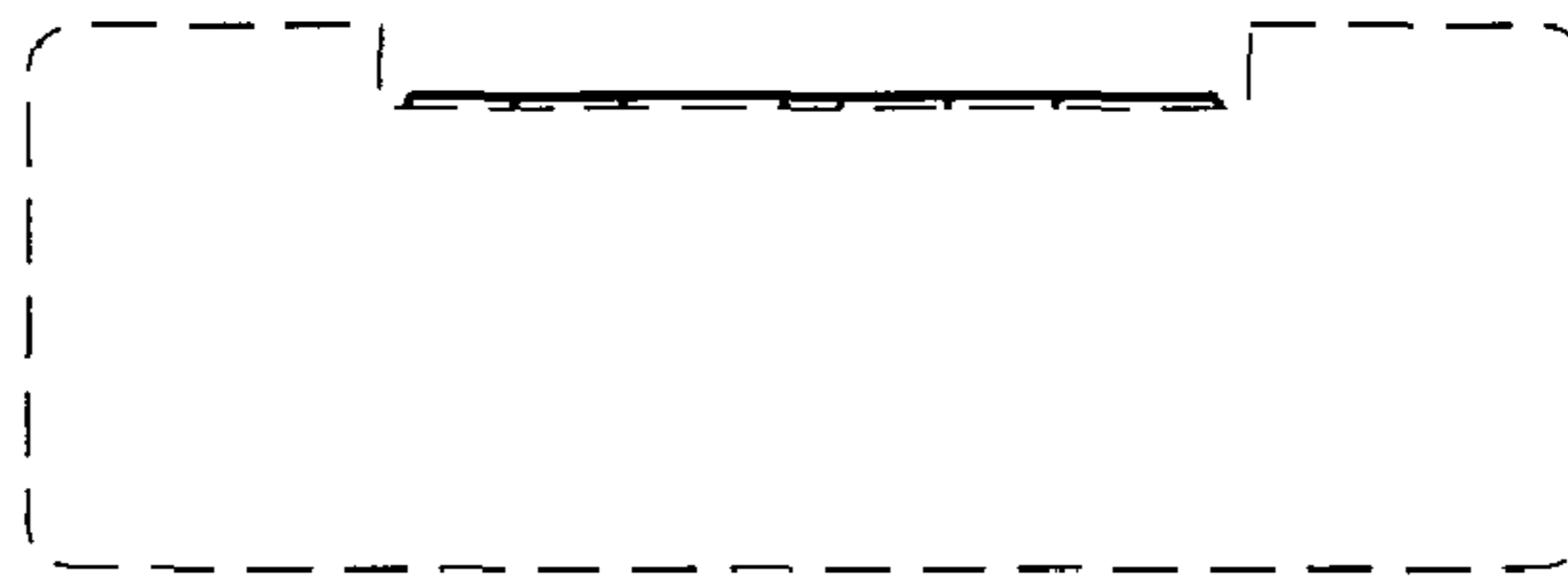

Fig. 20

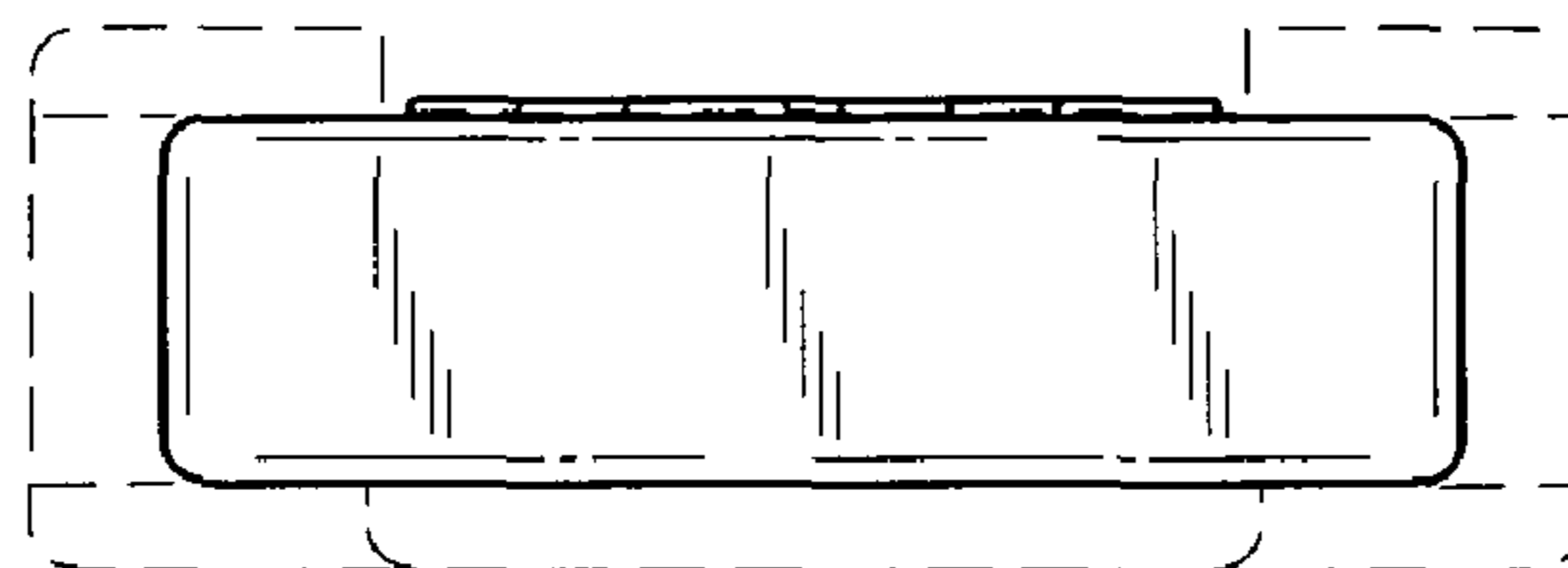

Fig. 21

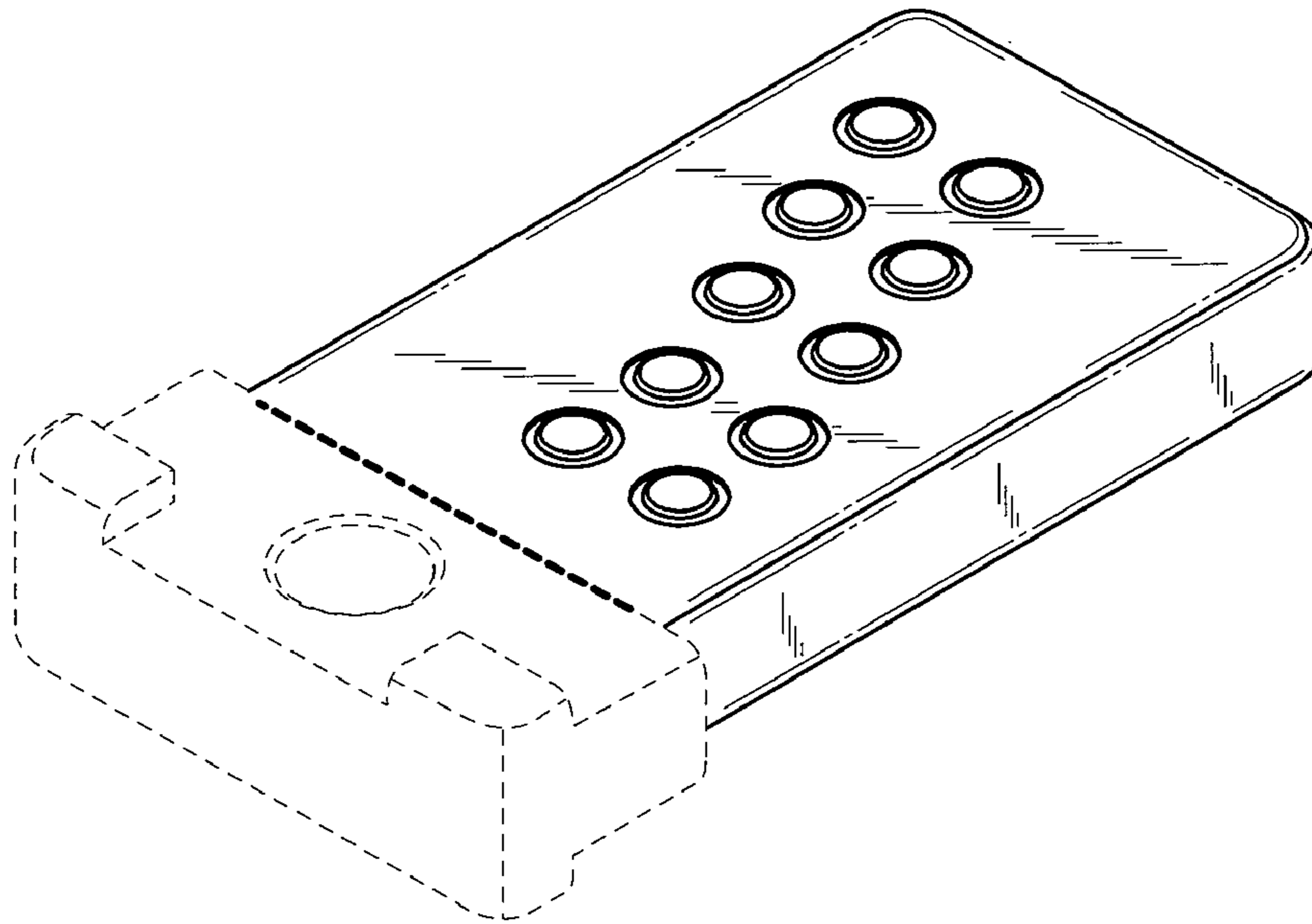

Fig. 22

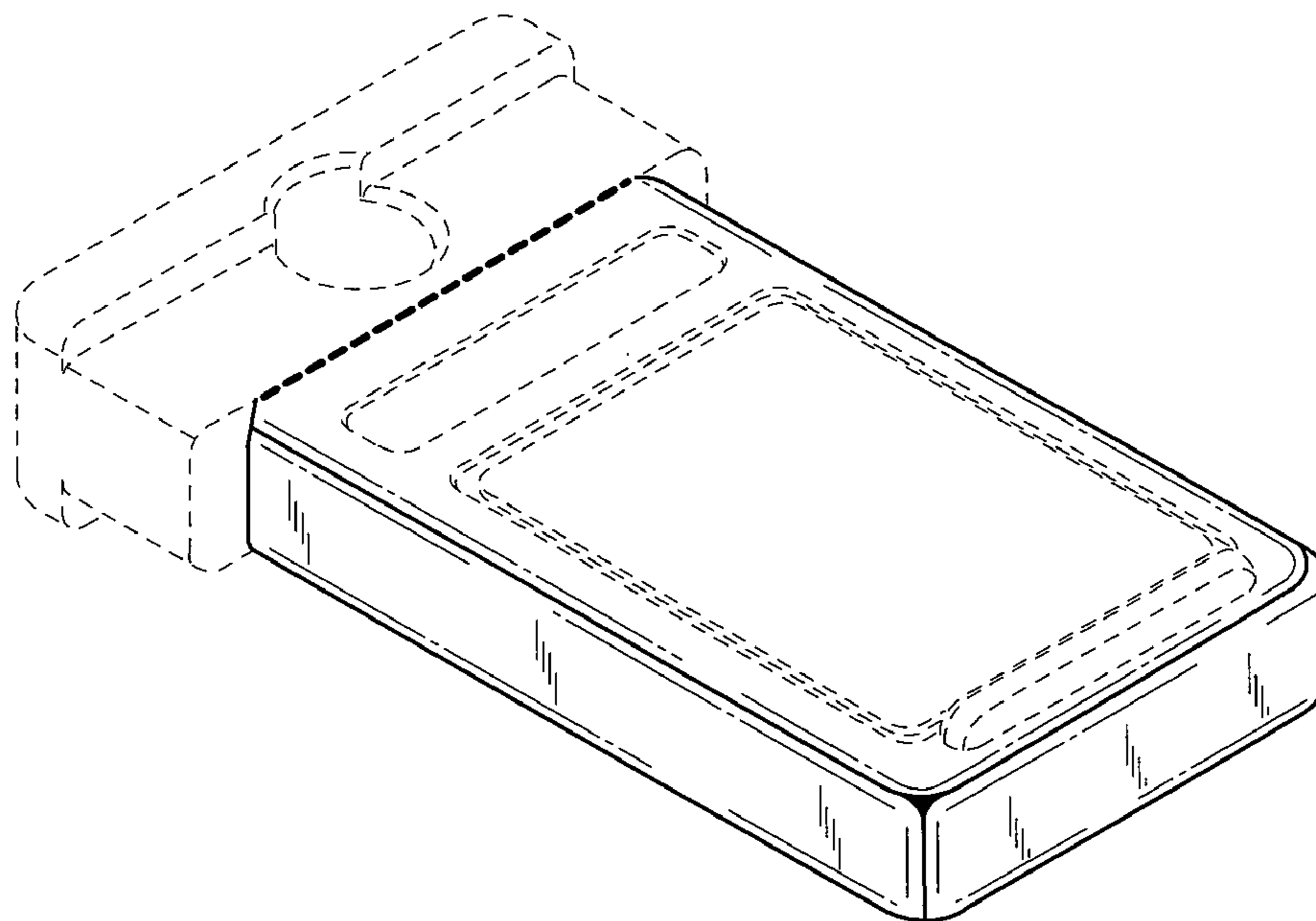

Fig. 23

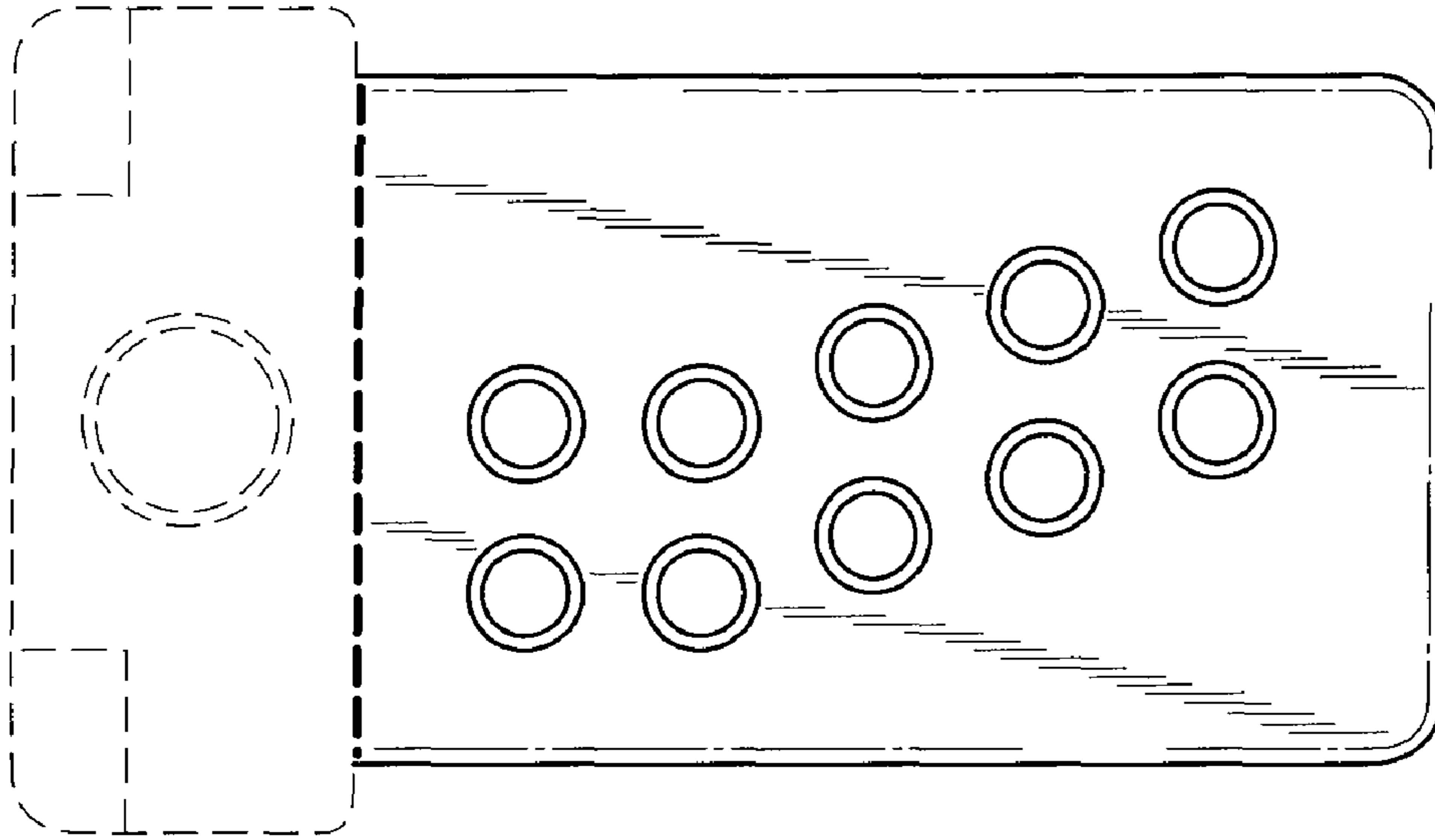

Fig. 24

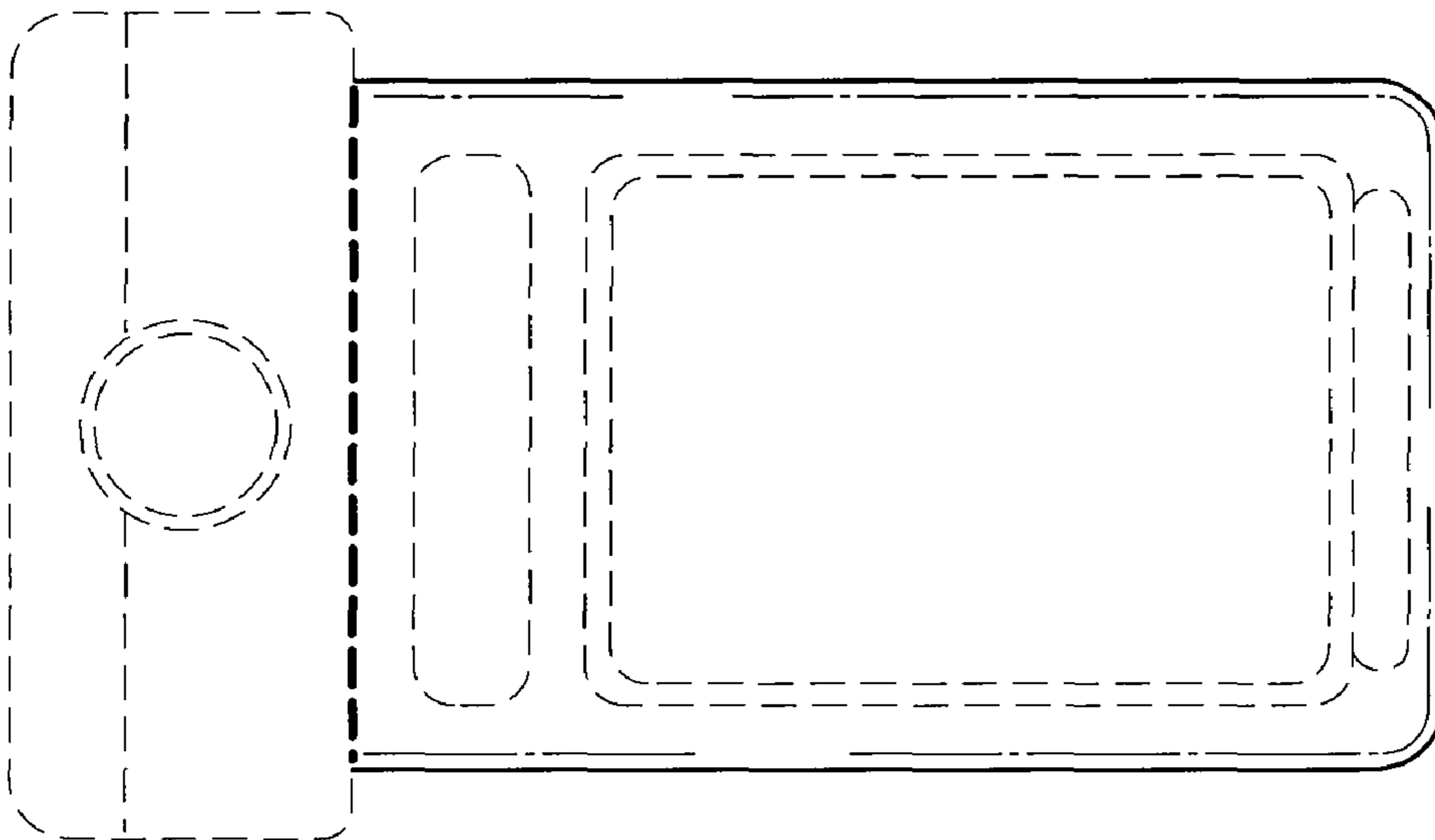

Fig. 25



Fig. 26

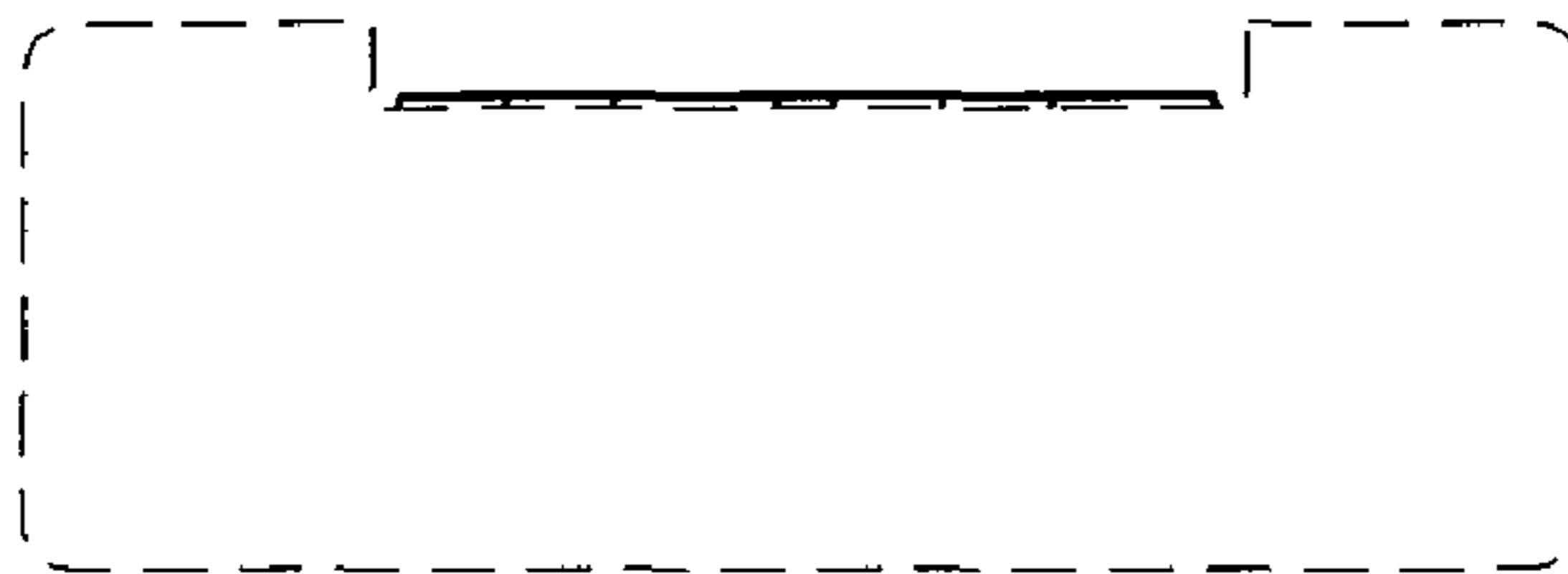

Fig. 27

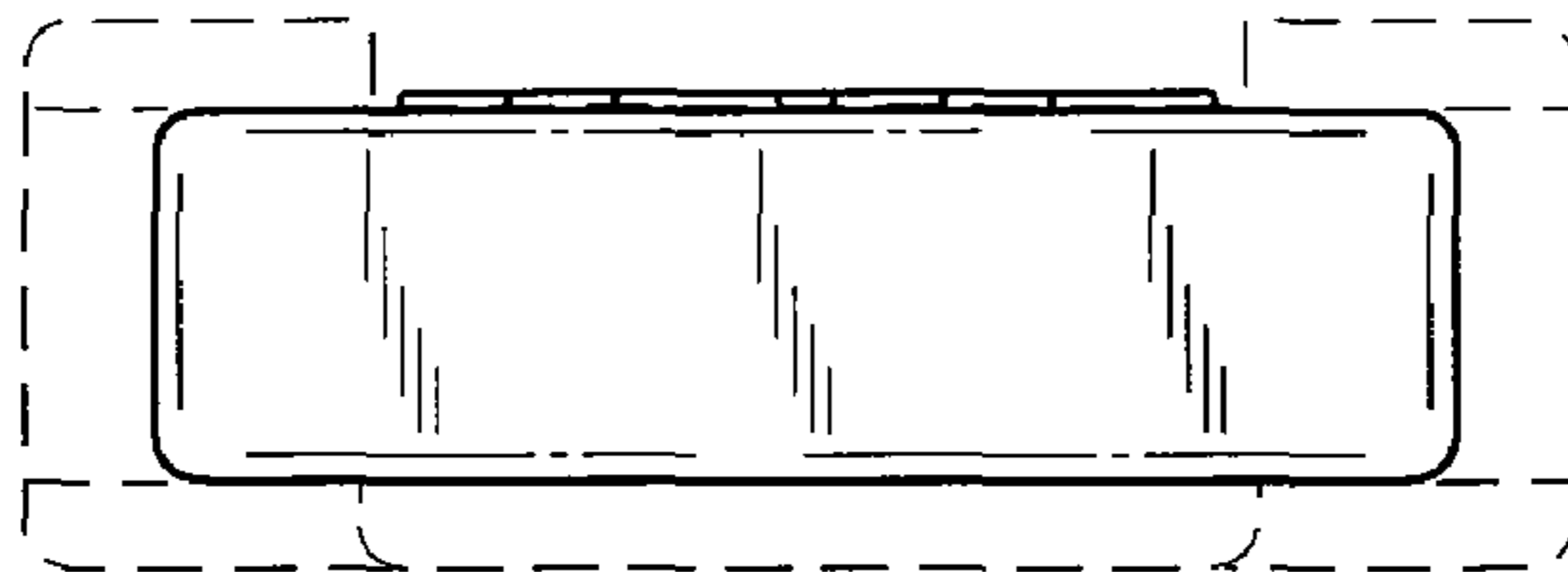

Fig. 28

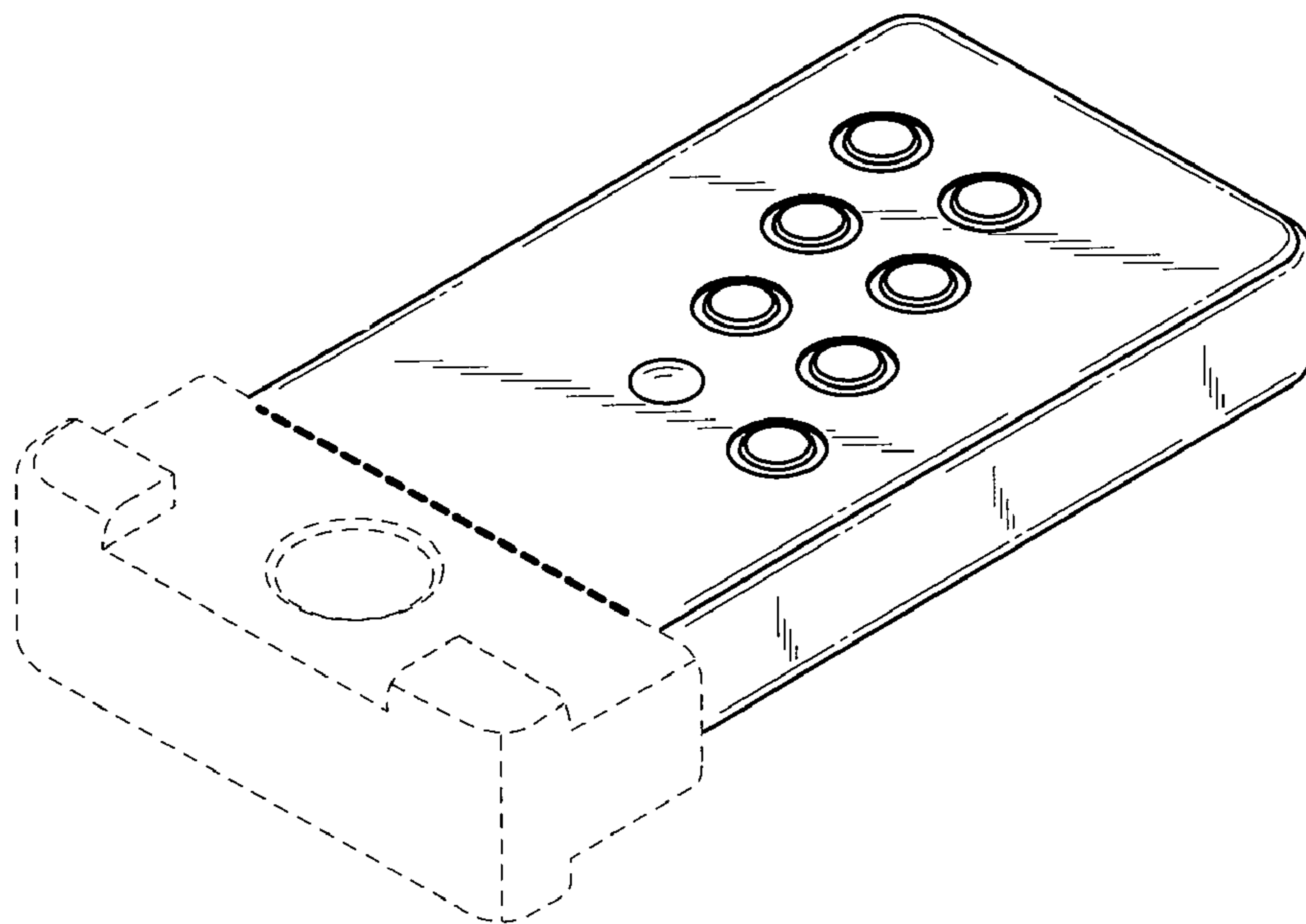

Fig. 29

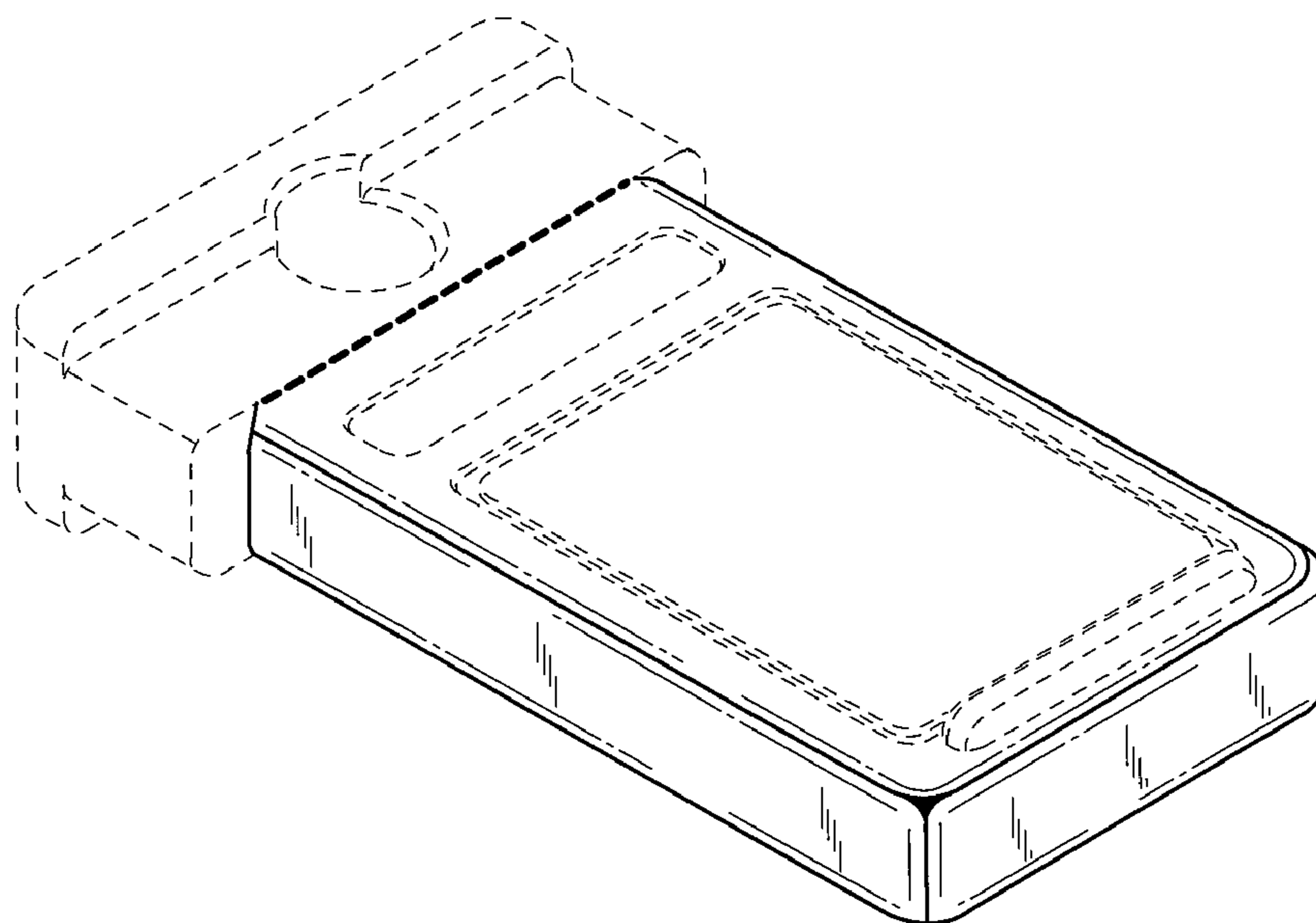

Fig. 30

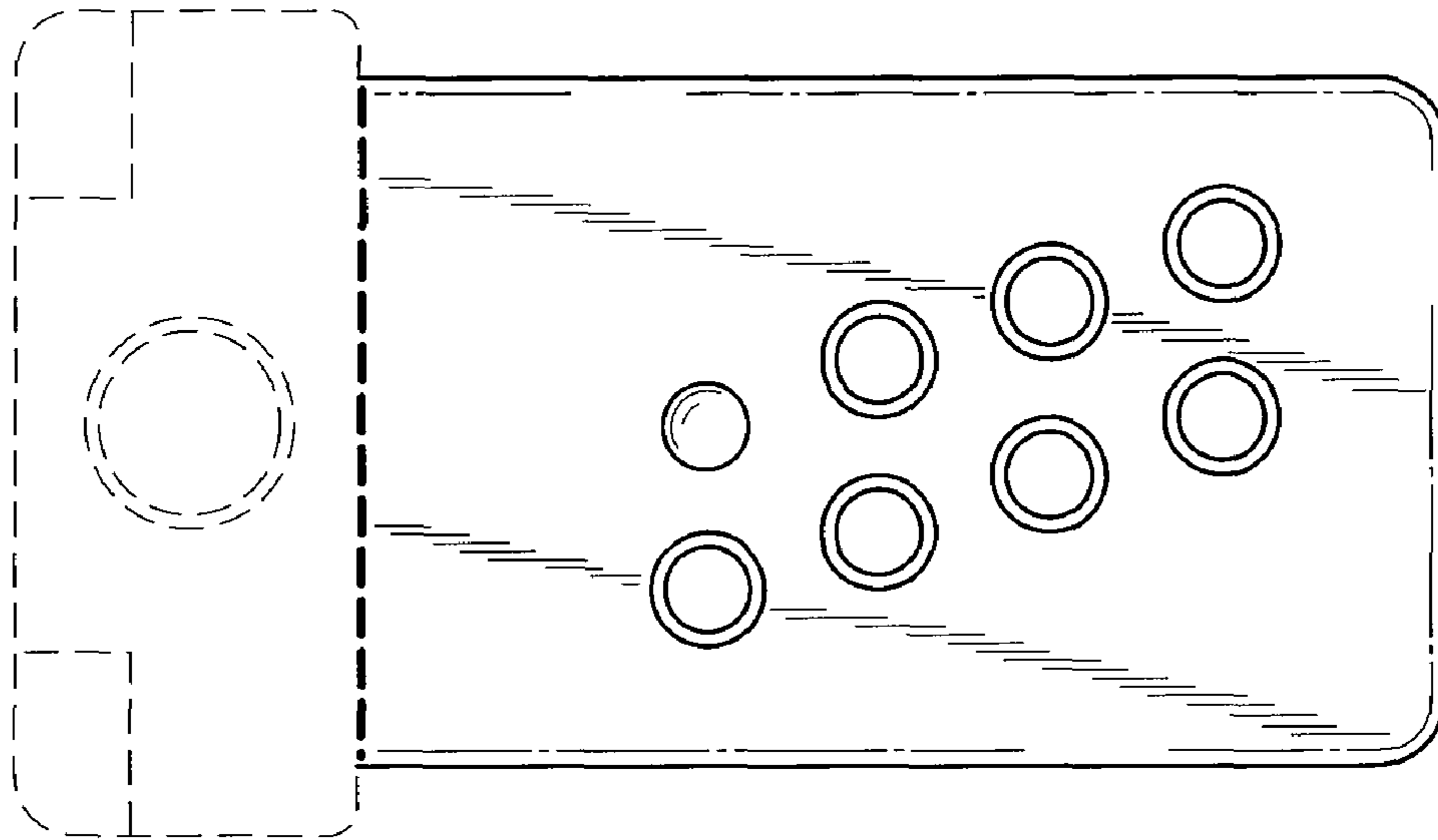

Fig. 31

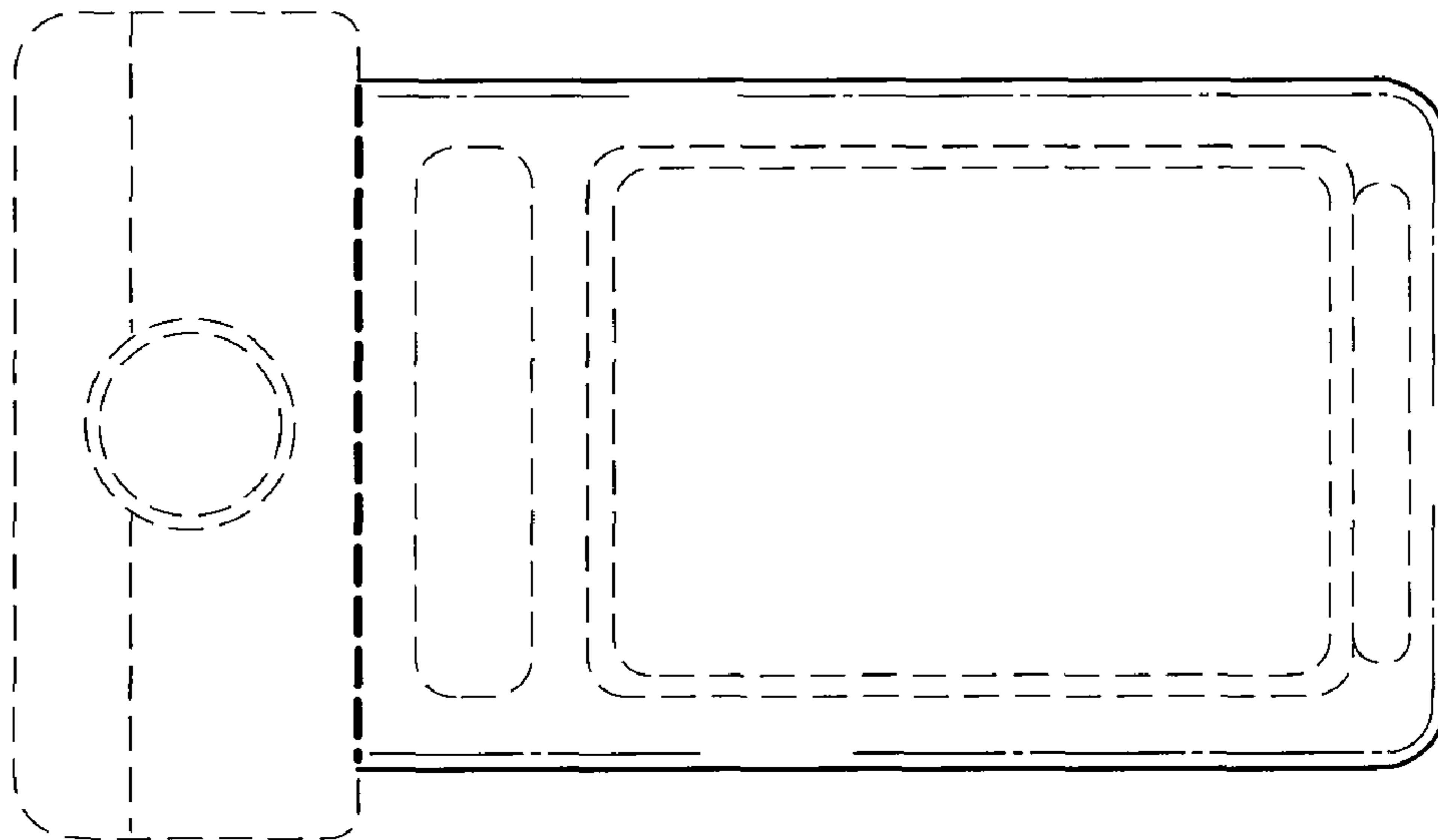

Fig. 32



Fig. 33

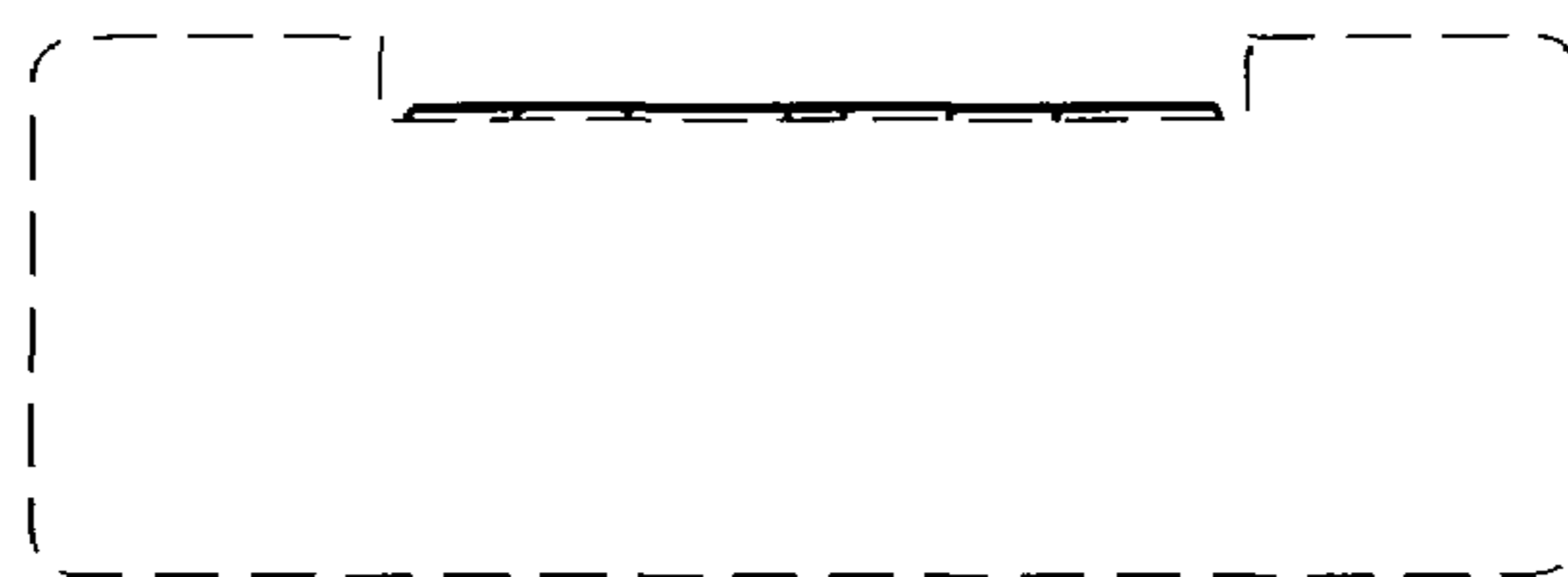

Fig. 34

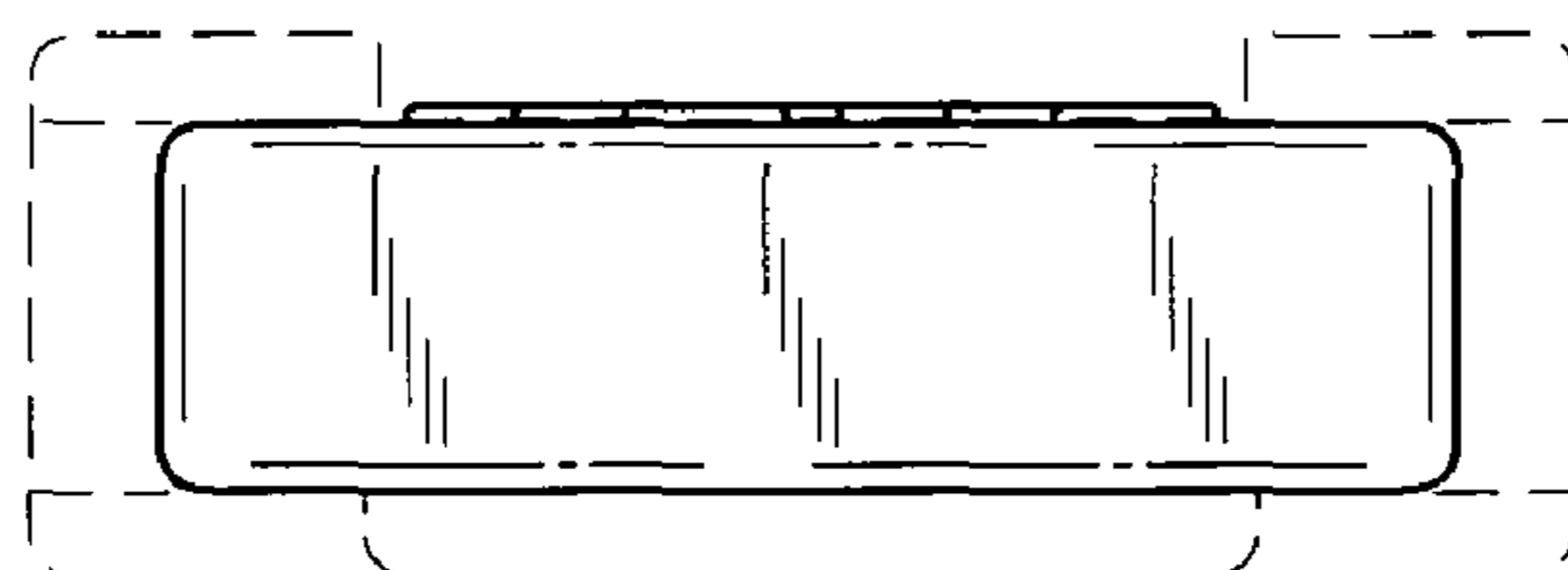

Fig. 35

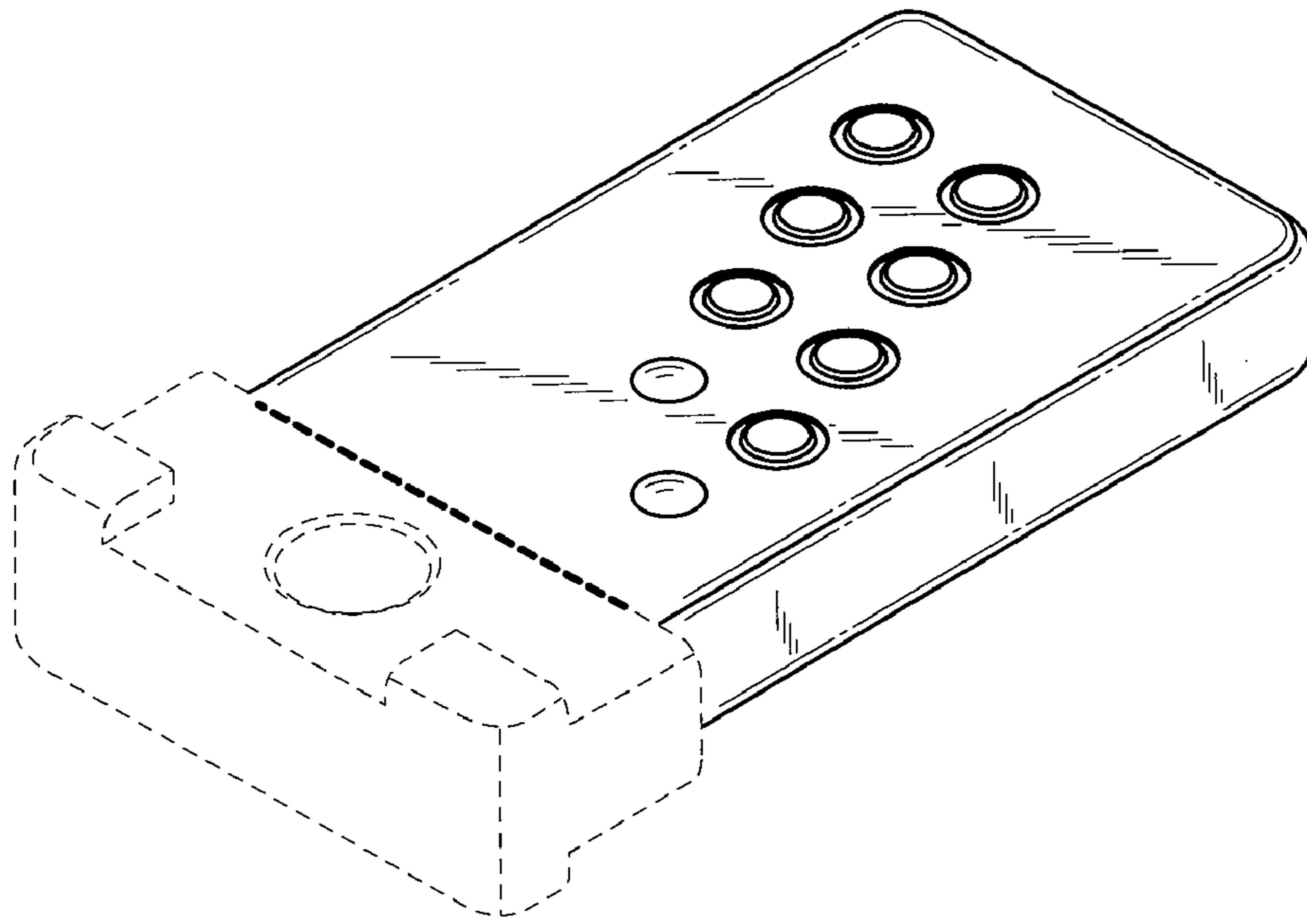

Fig. 36

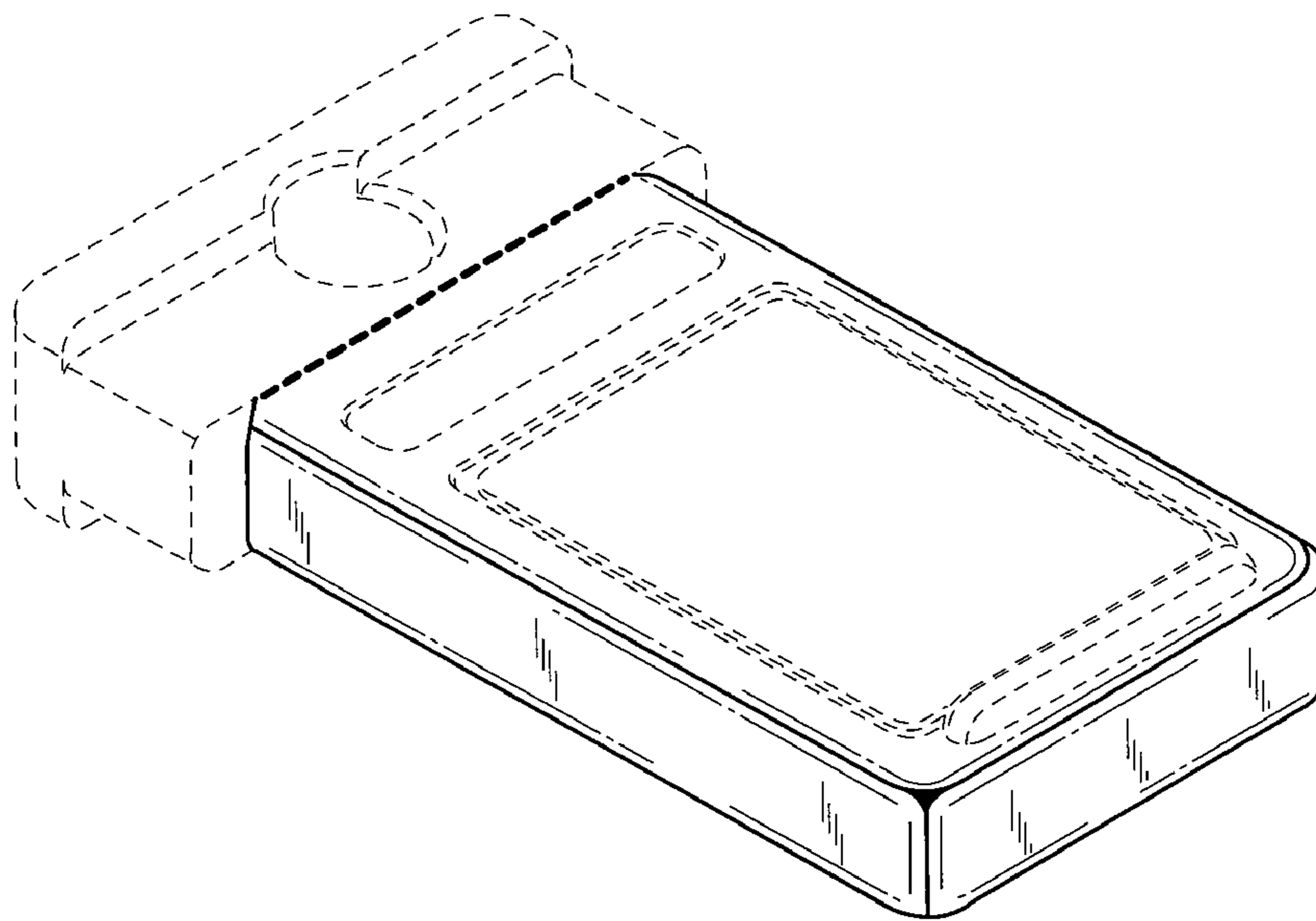

Fig. 37

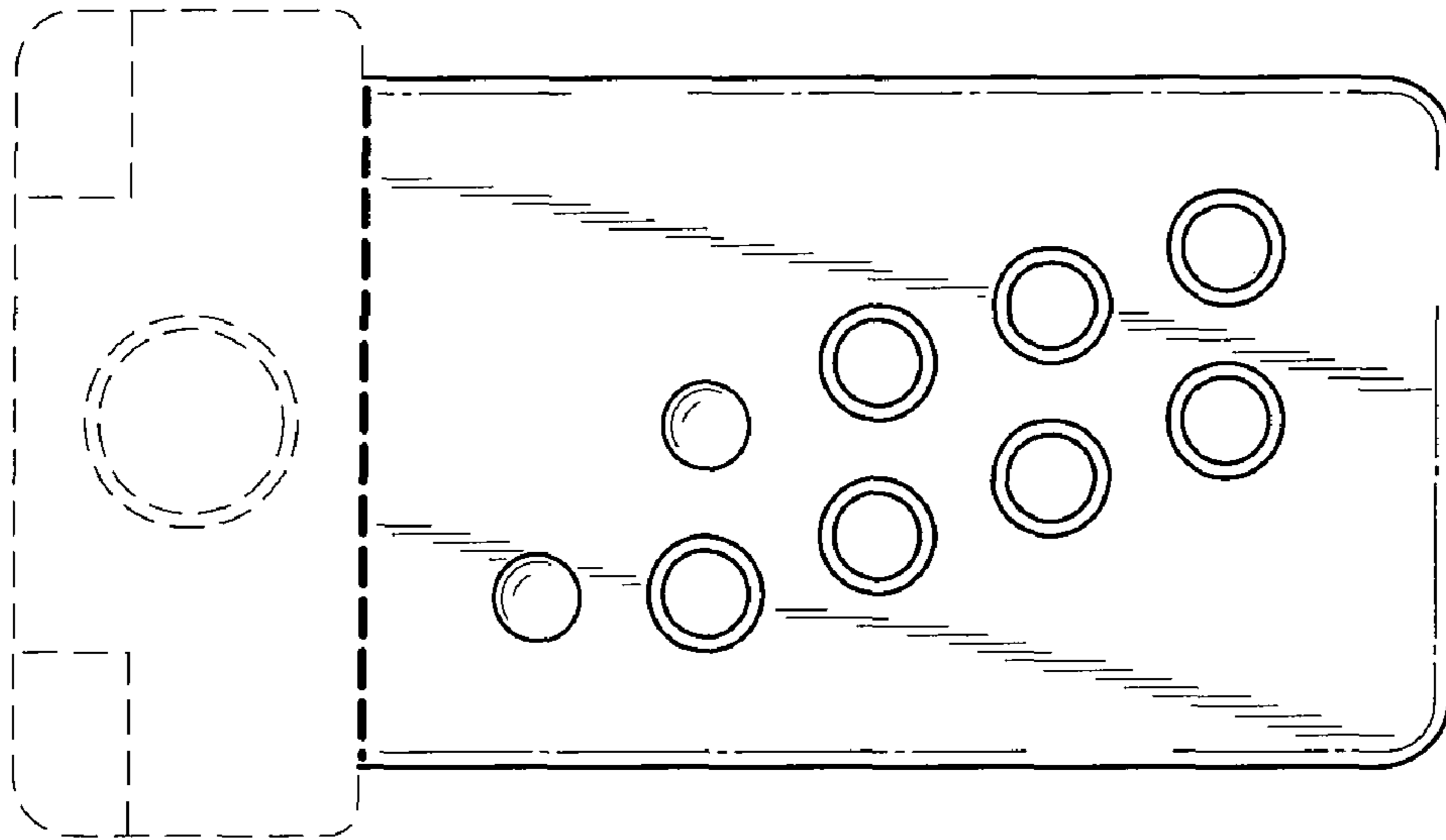

Fig. 38

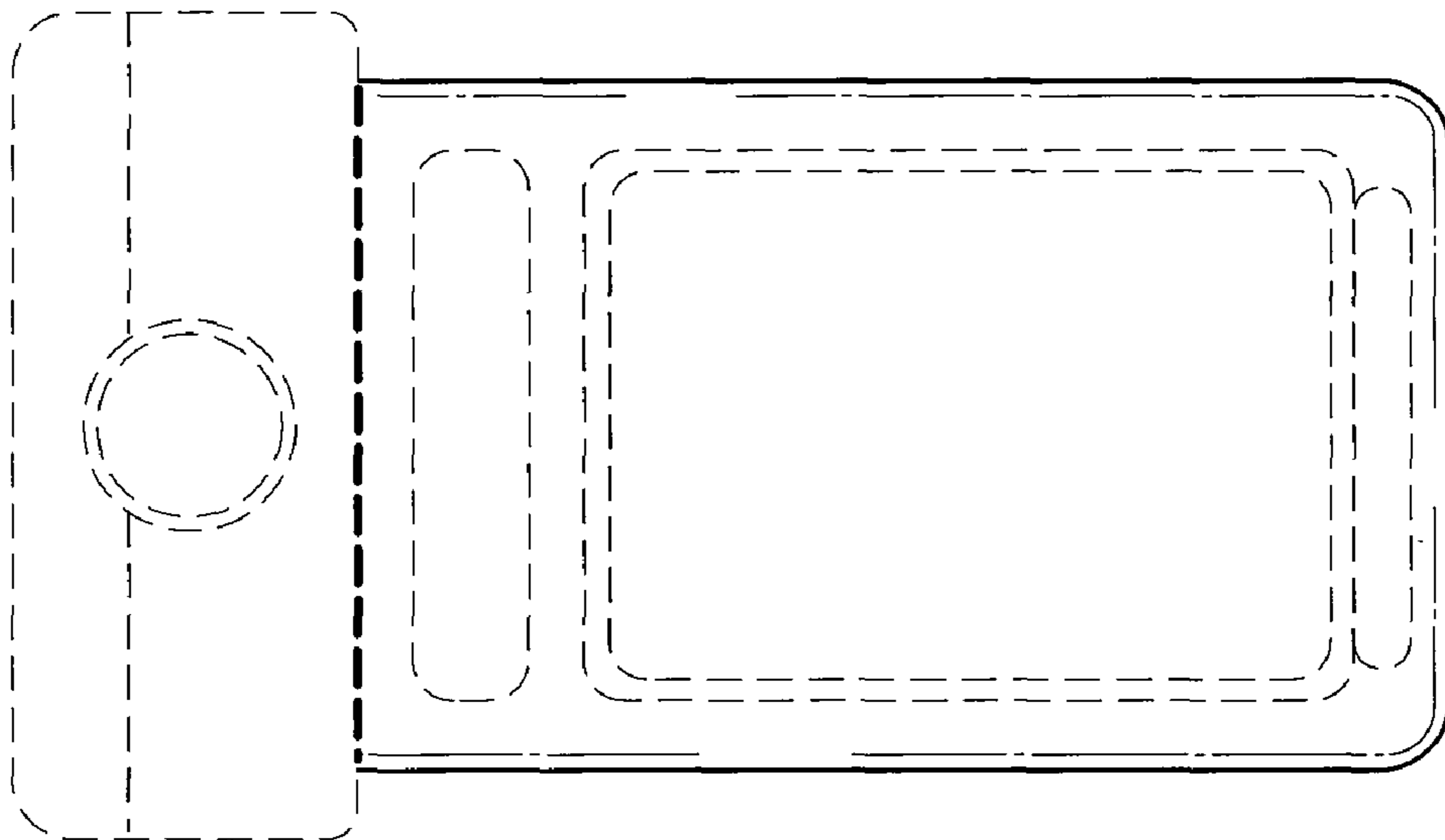

Fig. 39



Fig. 40

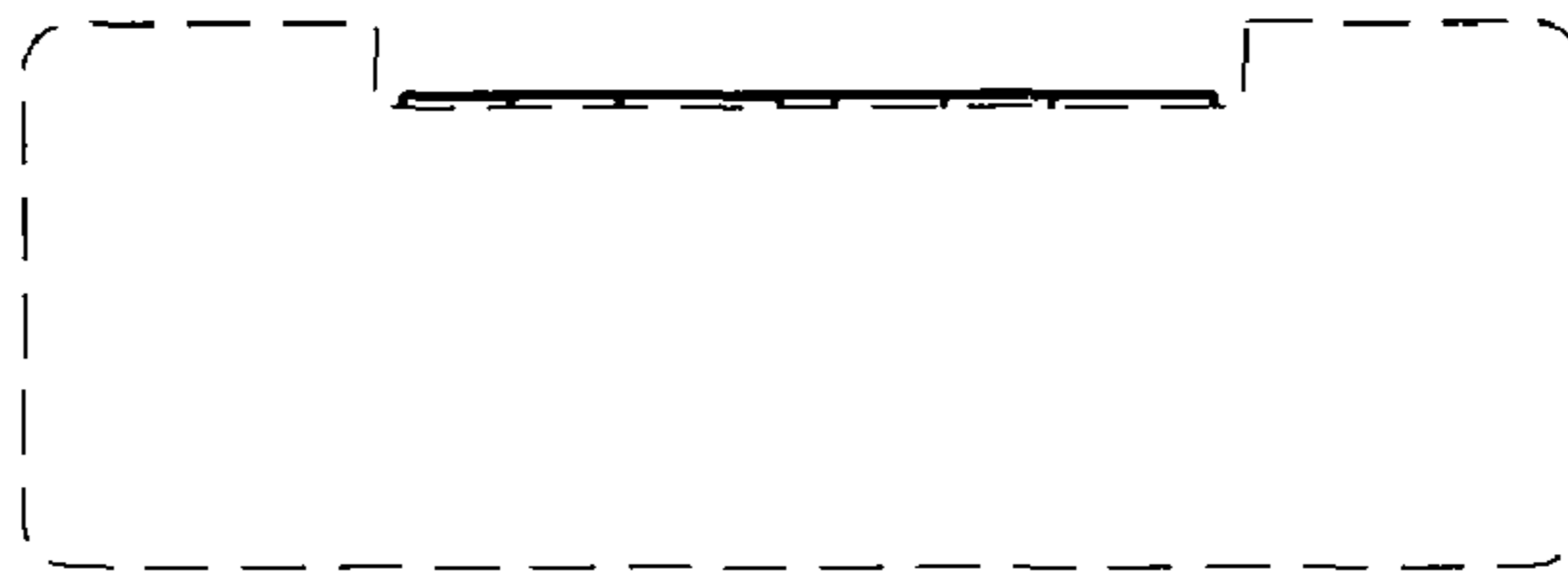

Fig. 41



Fig. 42

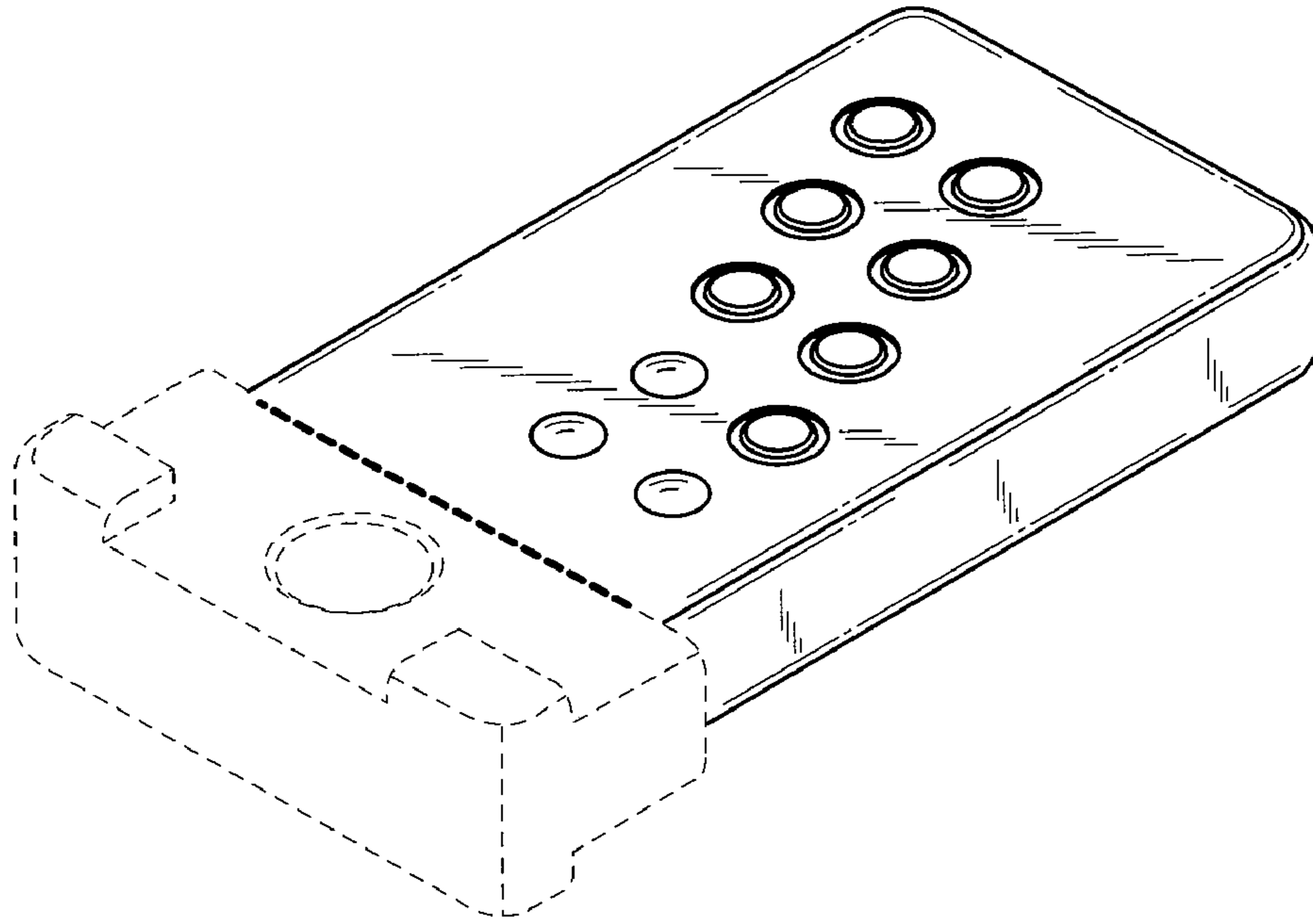

Fig. 43

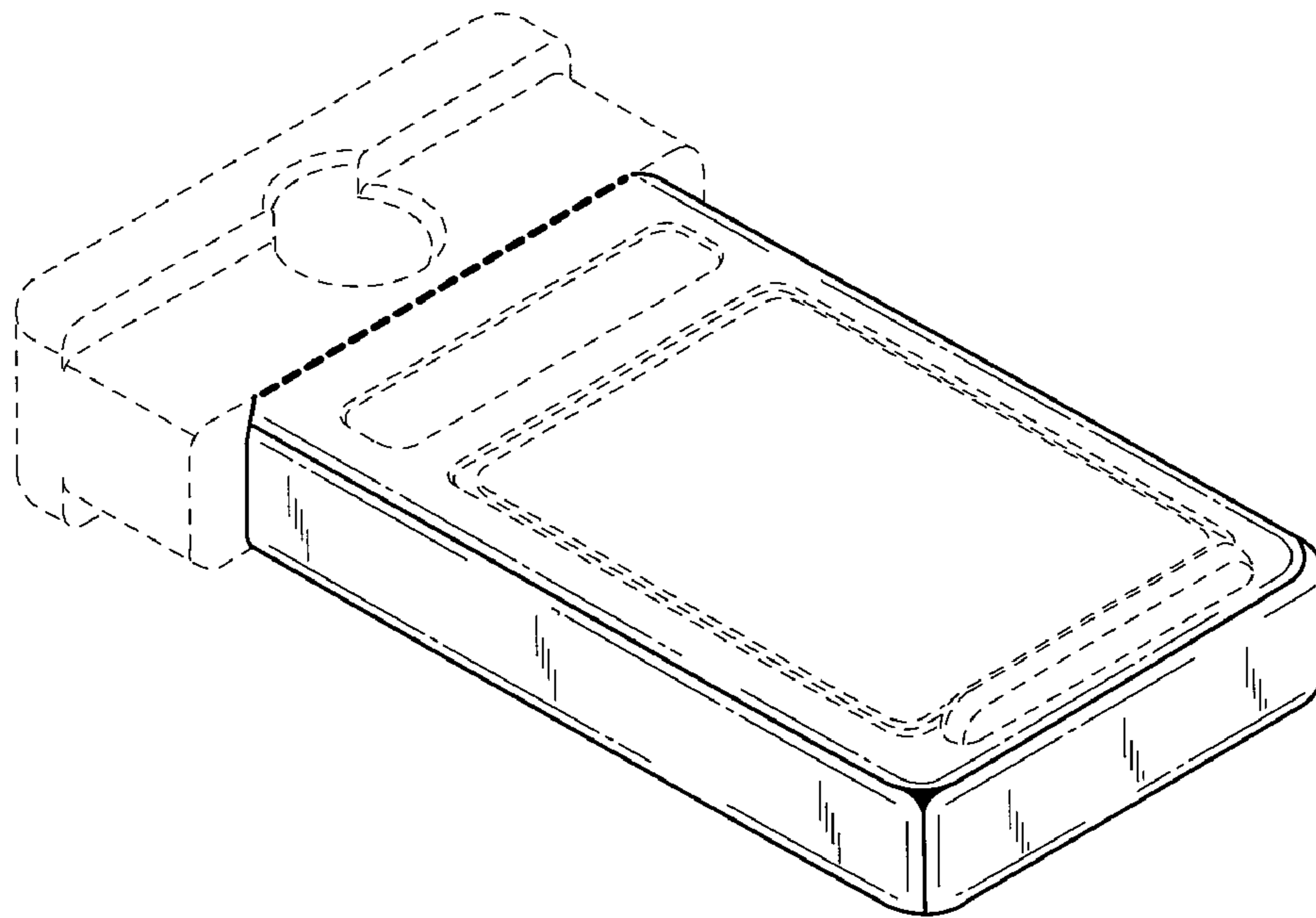

Fig. 44

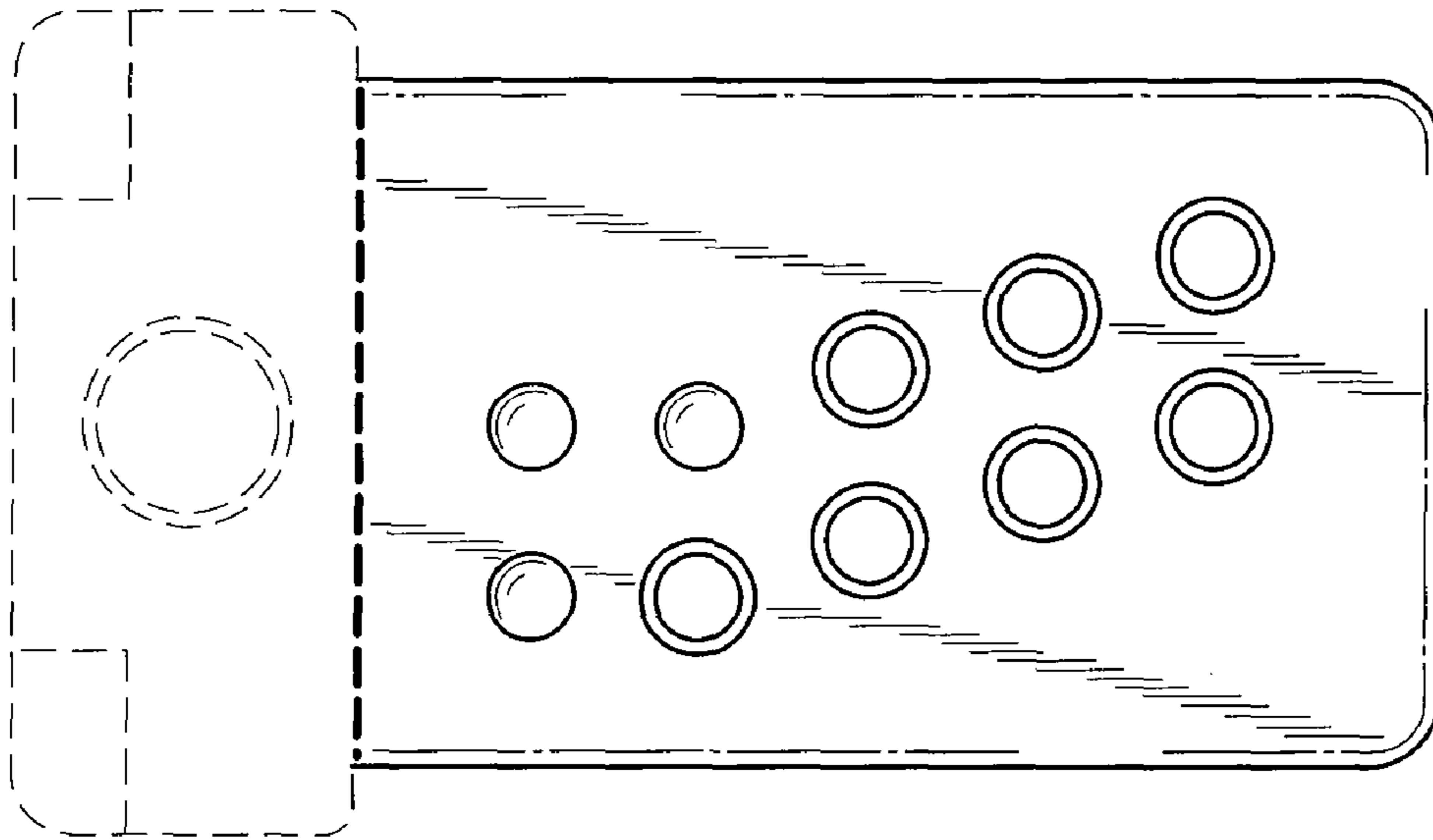

Fig. 45

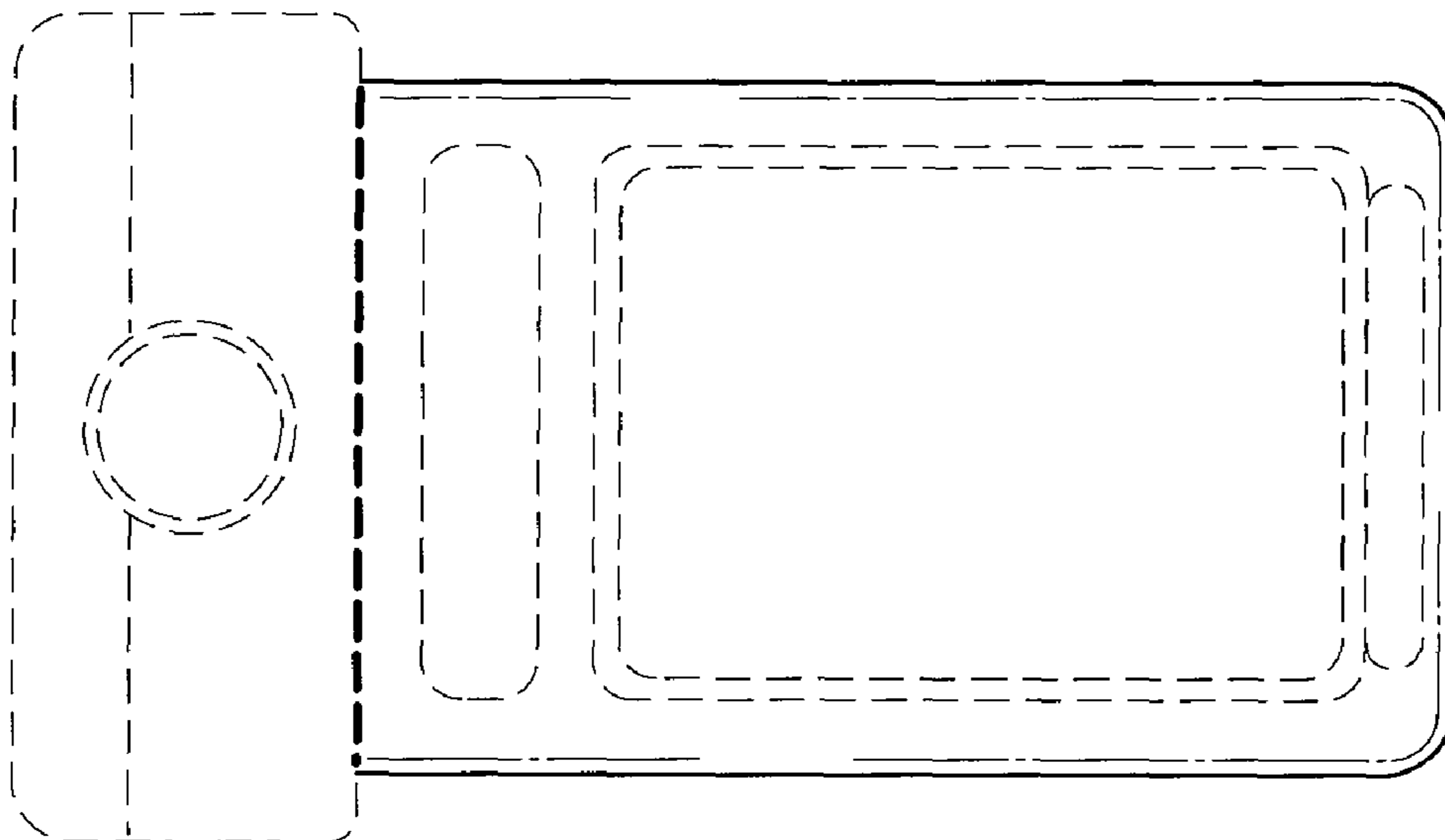

Fig. 46



Fig. 47

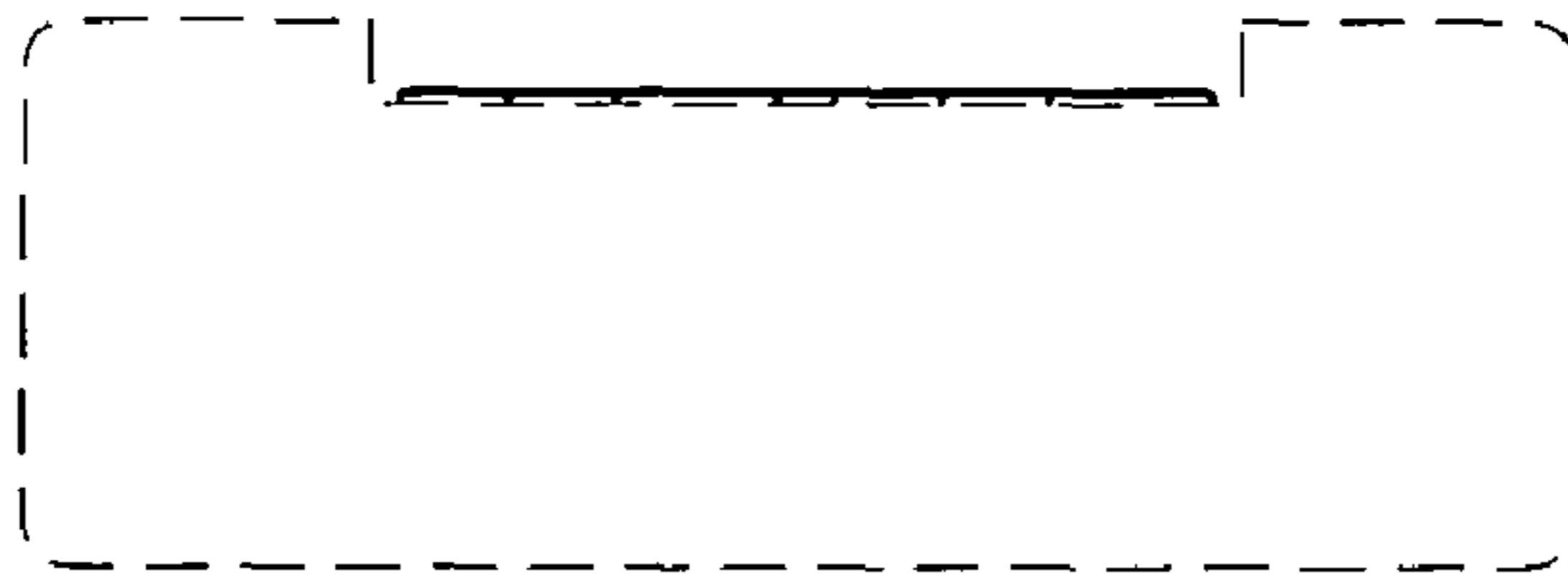

Fig. 48

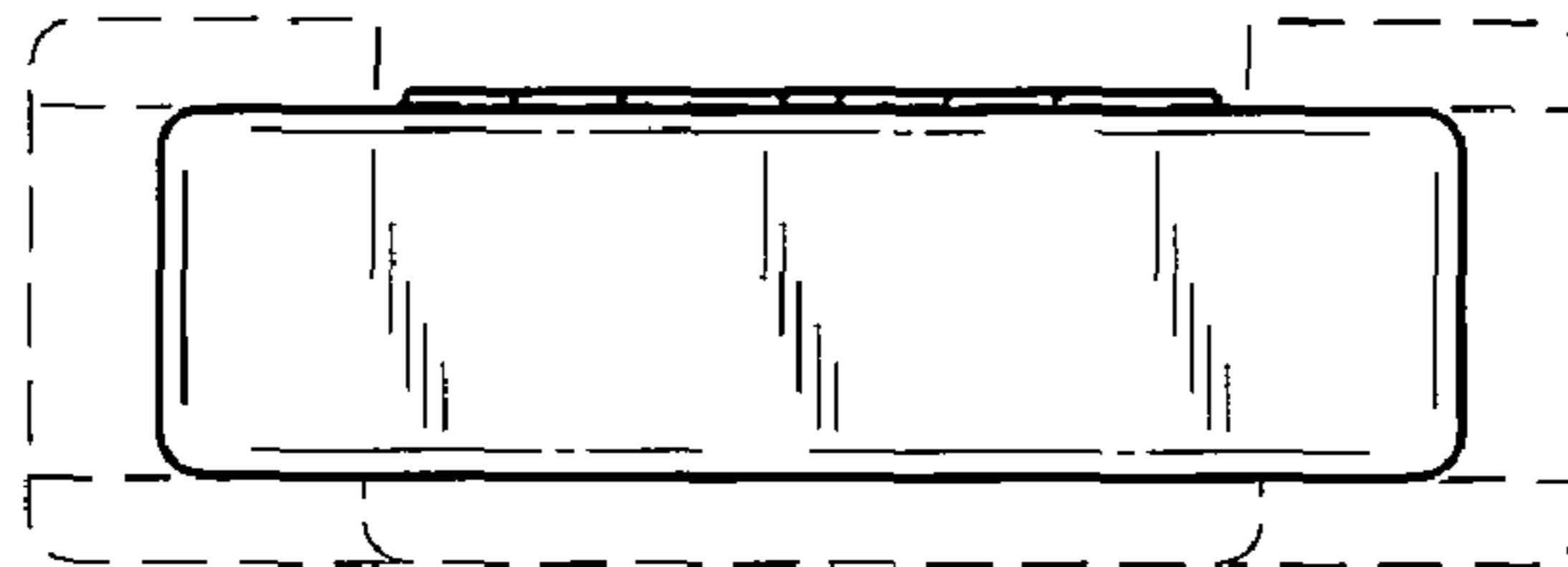

Fig. 49