



US00D649585S

(12) **United States Design Patent**
McCarthy

(10) **Patent No.:** **US D649,585 S**

(45) **Date of Patent:** **** Nov. 29, 2011**

(54) **GUITAR HEADSTOCK**

(76) Inventor: **Sean McCarthy**, East Northport, NY
(US)

(**) Term: **14 Years**

(21) Appl. No.: **29/385,332**

(22) Filed: **Feb. 11, 2011**

(51) **LOC (9) Cl.** **17-03**

(52) **U.S. Cl.** **D17/20**

(58) **Field of Classification Search** D17/14,
D17/18, 19, 20, 99; 84/723, 267, 290-293,
84/314 R, 453, 329

See application file for complete search history.

(56) **References Cited**

U.S. PATENT DOCUMENTS

D326,864 S *	6/1992	Tornese	D17/20
D331,068 S *	11/1992	Lindert	D17/20
D342,964 S *	1/1994	Harriott	D17/20
D346,395 S *	4/1994	Harriott	D17/20
D484,175 S *	12/2003	Baron	D17/20
D499,133 S *	11/2004	Hoffman	D17/14
D555,191 S *	11/2007	Peavey	D17/20
D557,331 S *	12/2007	Clark	D17/20
D564,575 S *	3/2008	Csakvary	D17/20
D567,846 S *	4/2008	Dudzik et al.	D17/20

D568,925 S *	5/2008	Lechner	D17/14
D594,502 S *	6/2009	Csakvary	D17/14
D624,113 S *	9/2010	Faulisi	D17/21

* cited by examiner

Primary Examiner — Ian Simmons

Assistant Examiner — Rashida Johnson

(74) *Attorney, Agent, or Firm* — Tutunjian & Bitetto, P.C.

(57) **CLAIM**

The ornamental design for a guitar headstock, as shown and described.

DESCRIPTION

FIG. 1 is a perspective view of the guitar headstock showing my new design;

FIG. 2 is a front view thereof;

FIG. 3 is a rear view thereof;

FIG. 4 is left side view thereof;

FIG. 5 is a right side view thereof; and,

FIG. 6 is a top view thereof.

Throughout the views, the bottommost broken line of the guitar headstock represents the boundary of the claimed design. The remaining broken lines represent the portions of the design, which form no part of the claim.

1 Claim, 2 Drawing Sheets

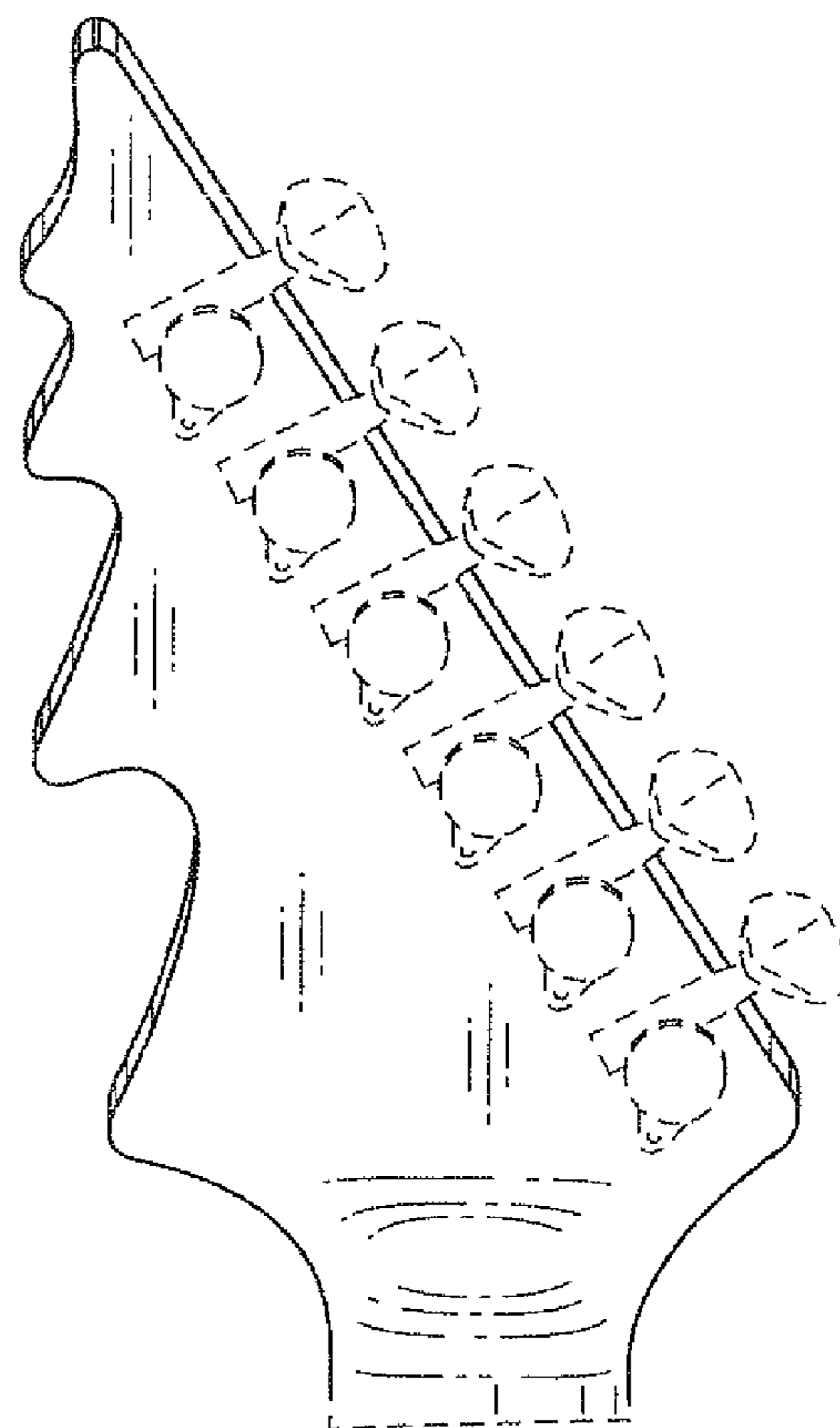
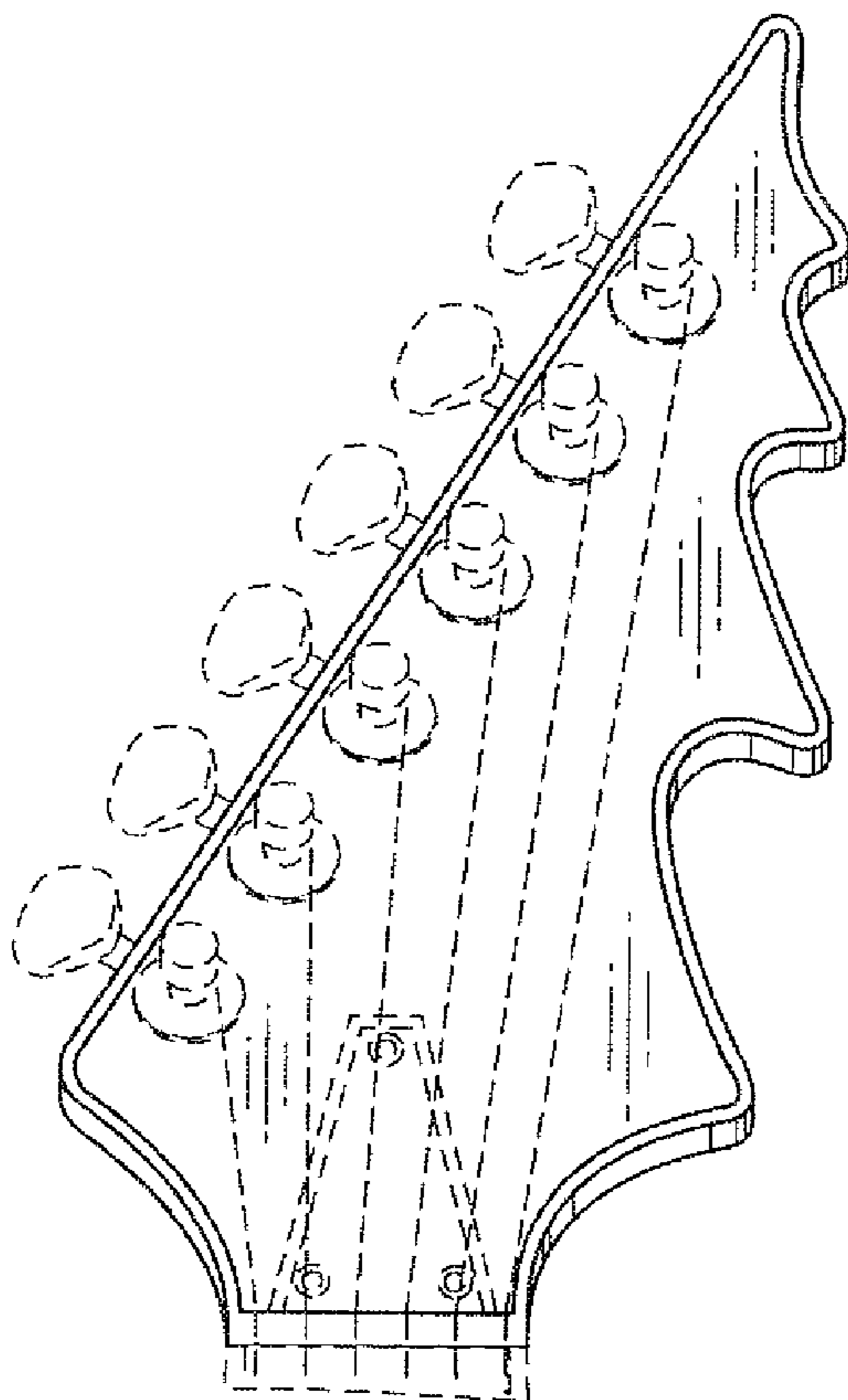

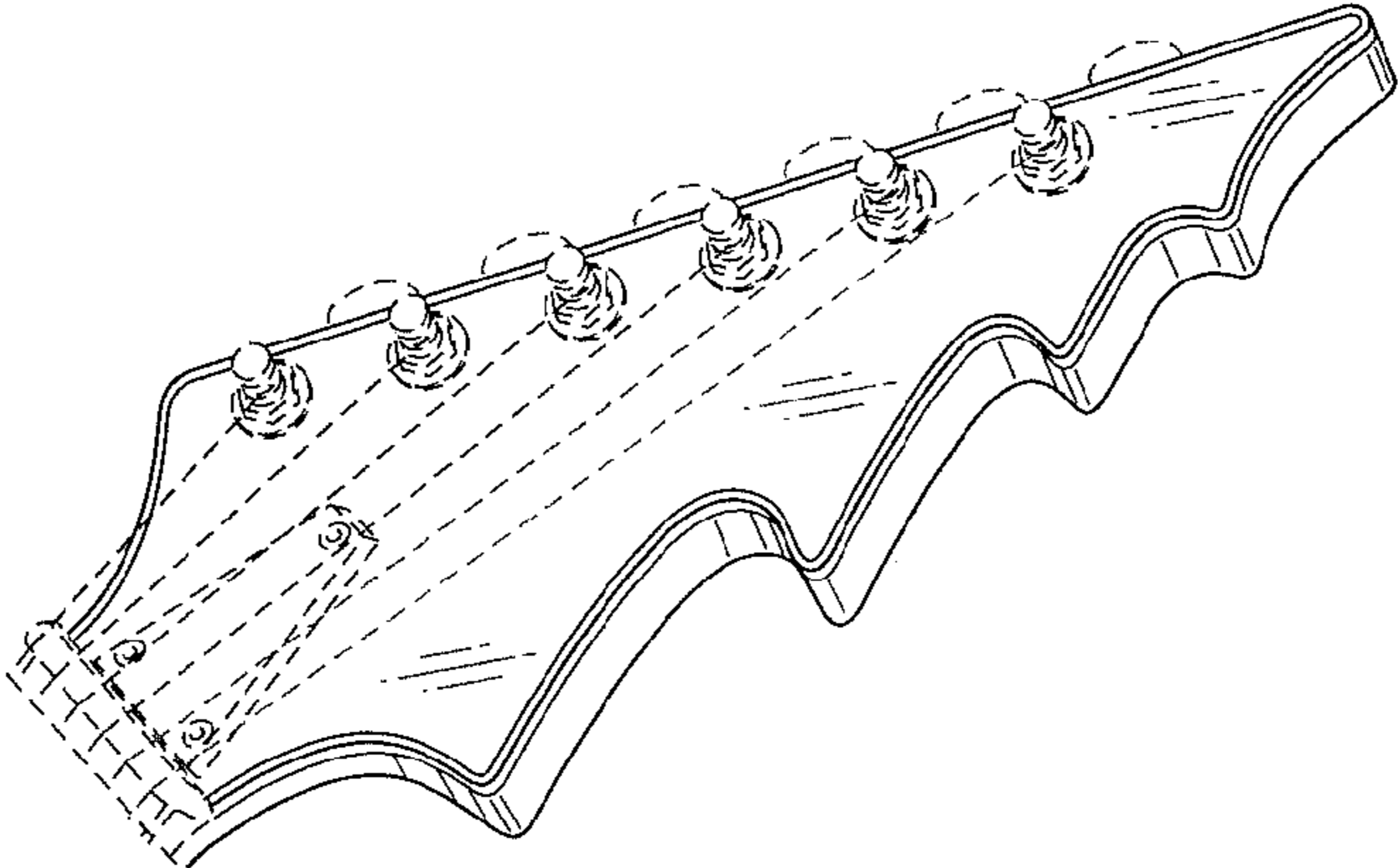

FIG. 1

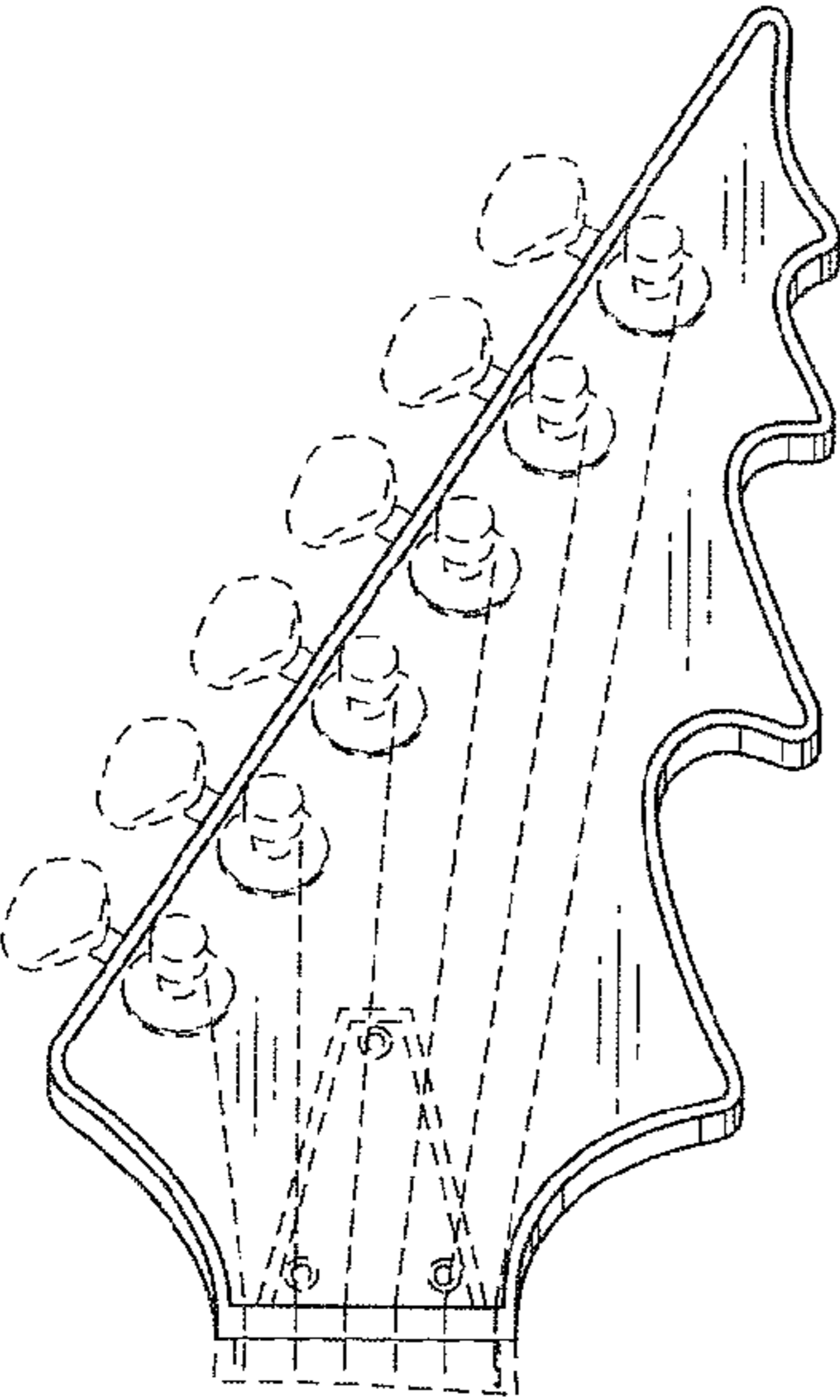

FIG. 2

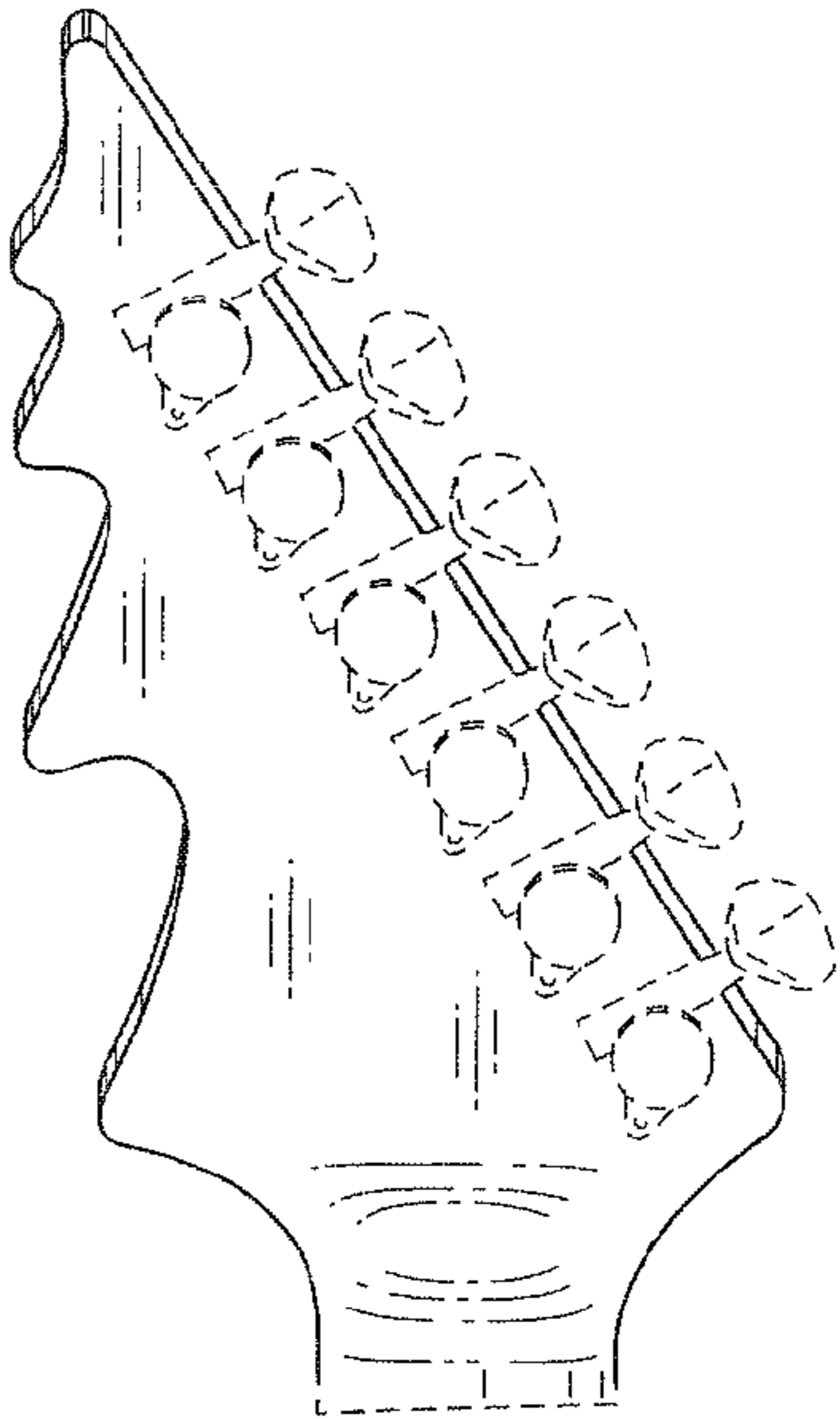

FIG. 3

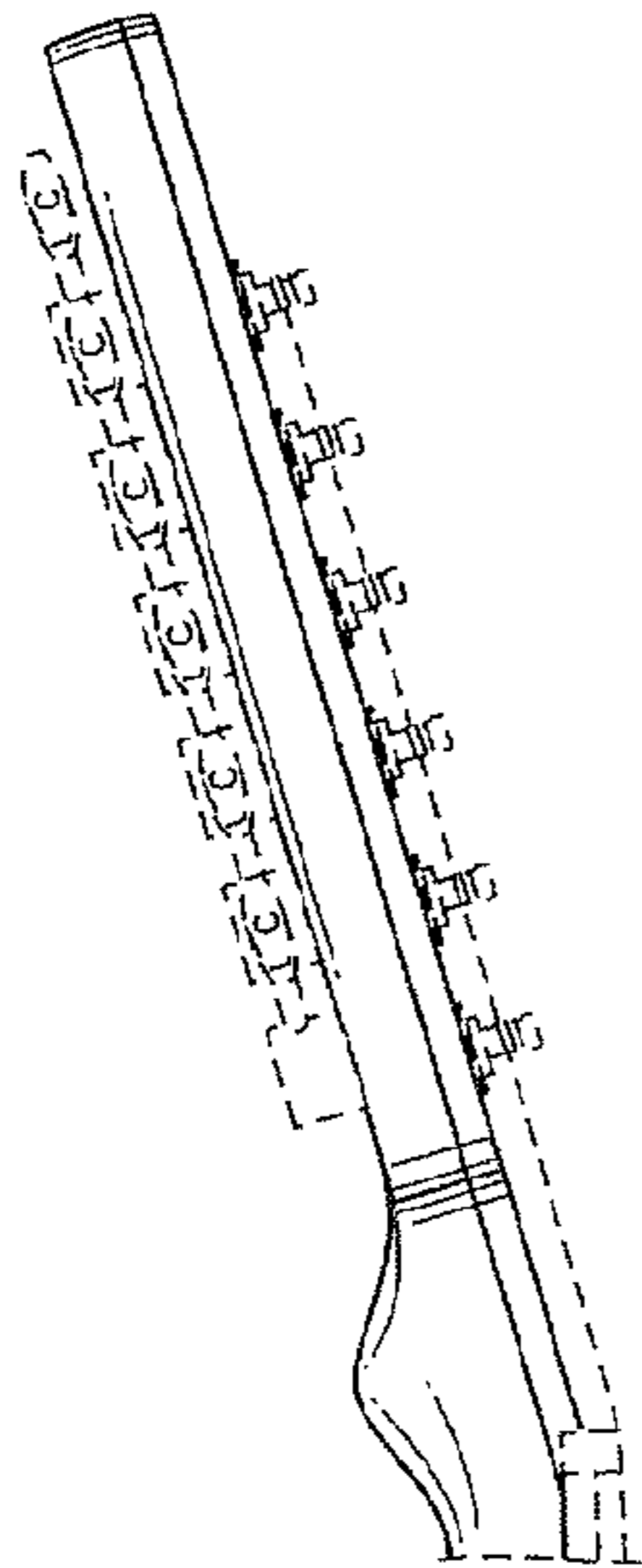

FIG. 4

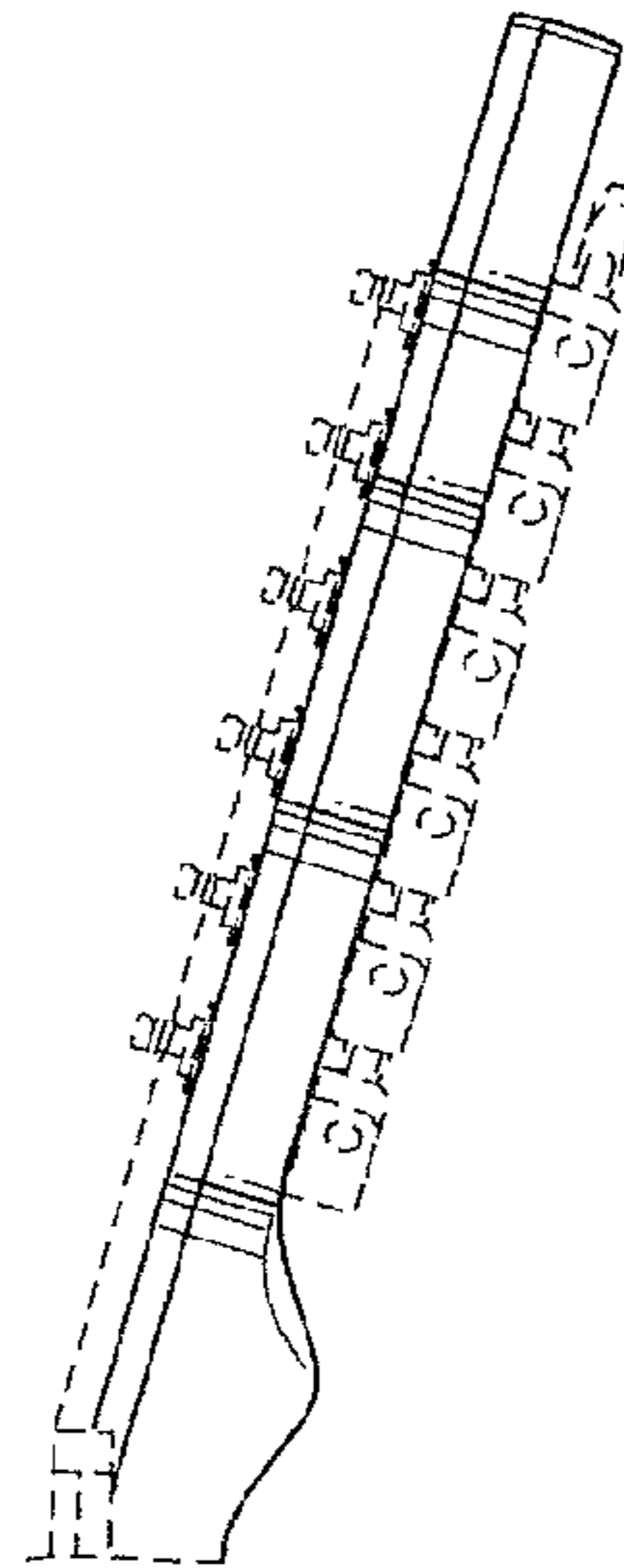

FIG. 5

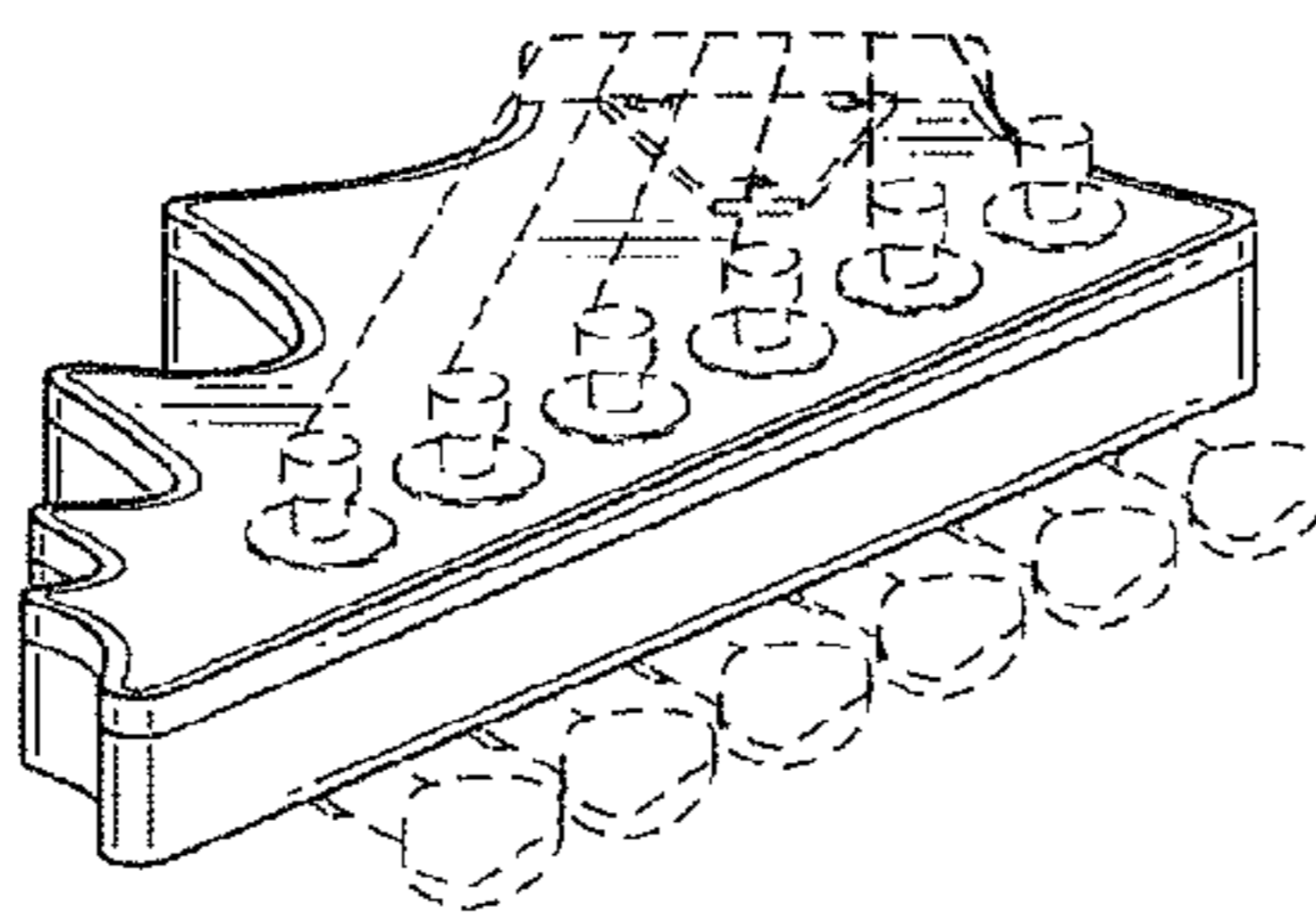

FIG. 6