



US00D649563S

(12) **United States Design Patent**  
**Doraivelmanimoz**

(10) **Patent No.:** **US D649,563 S**

(45) **Date of Patent:** **\*\* Nov. 29, 2011**

(54) **STEP**

(75) **Inventor:** **Kannan Doraivelmanimoz**, Chennai  
(IN)

(73) **Assignee:** **Caterpillar Inc.**, Peoria, IL (US)

(\*\*) **Term:** **14 Years**

(21) **Appl. No.:** **29/372,085**

(22) **Filed:** **Oct. 13, 2010**

(30) **Foreign Application Priority Data**

Apr. 15, 2010 (IN) ..... 228611

(51) **LOC (9) Cl.** ..... **15-03**

(52) **U.S. Cl.** ..... **D15/28; D12/203**

(58) **Field of Classification Search** ..... D15/10,  
D15/28; D12/203, 400; D25/62, 69, 68;  
280/163, 169, 164, 166; 182/90, 92  
See application file for complete search history.

(56) **References Cited**

**U.S. PATENT DOCUMENTS**

1,415,699	A *	5/1922	Porter	.....	182/90
3,171,671	A *	3/1965	Cornett	.....	280/163
3,422,923	A *	1/1969	Lund	.....	182/120
D225,160	S *	11/1972	Thomas	.....	D12/203
D229,045	S *	11/1973	Woodall	.....	D12/203
3,915,475	A *	10/1975	Casella et al.	.....	280/166
4,569,533	A *	2/1986	Gronert et al.	.....	280/163
D290,833	S *	7/1987	Walters	.....	D12/203
D296,321	S *	6/1988	Hayes	.....	D12/203
D306,278	S *	2/1990	Hafvenstein	.....	D12/203

D313,388	S *	1/1991	Dale	.....	D12/203
D340,904	S *	11/1993	Bevier	.....	D12/203
D343,692	S *	1/1994	Rainio	.....	D25/69
5,312,150	A *	5/1994	Quam	.....	296/62
D381,948	S *	8/1997	Schult	.....	D12/203
D412,754	S *	8/1999	Harden	.....	D25/69
D445,076	S *	7/2001	Weinerman	.....	D12/203
D469,449	S *	1/2003	Andrews	.....	D15/33
D573,929	S *	7/2008	Black	.....	D12/203
7,416,232	B2 *	8/2008	Tier et al.	.....	293/117
D607,395	S *	1/2010	Beigel et al.	.....	D12/203
2002/0003340	A1 *	1/2002	Hallquist	.....	280/163
2004/0178602	A1 *	9/2004	King et al.	.....	280/163

\* cited by examiner

*Primary Examiner* — Mark Goodwin

(74) *Attorney, Agent, or Firm* — Liell & McNeil

(57) **CLAIM**

The ornamental design for a step, as shown and described.

**DESCRIPTION**

FIG. 1 is a side perspective view of a step according to my new design;

FIG. 2 is a bottom perspective view thereof;

FIG. 3 is a side view thereof;

FIG. 4 is a top view thereof;

FIG. 5 is a top perspective view thereof;

FIG. 6 is a front view thereof; and,

FIG. 7 is a back view thereof.

Footstep for attachment to a machine, such as a track type tractor, to facilitate operator access to the operator cab of the machine.

**1 Claim, 7 Drawing Sheets**

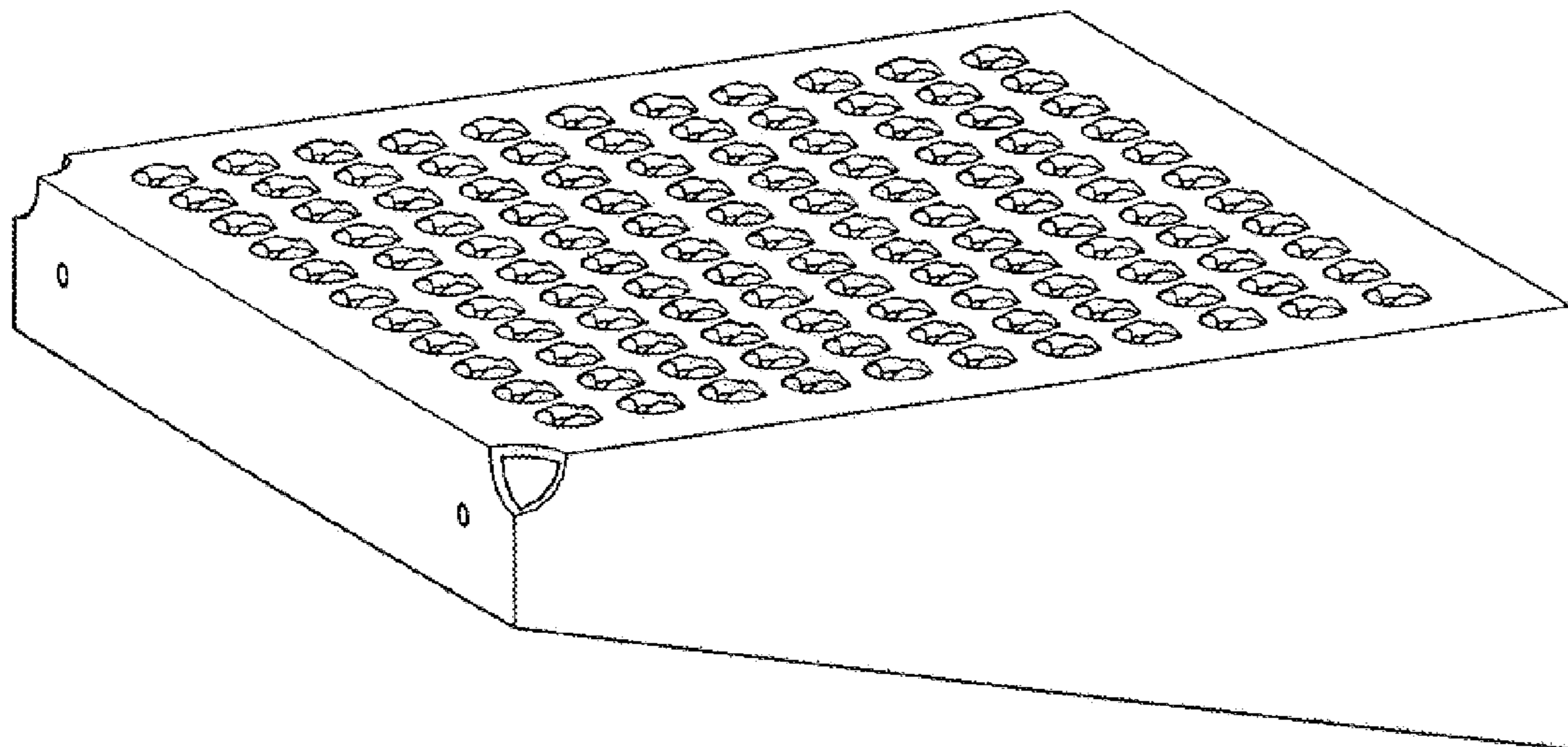

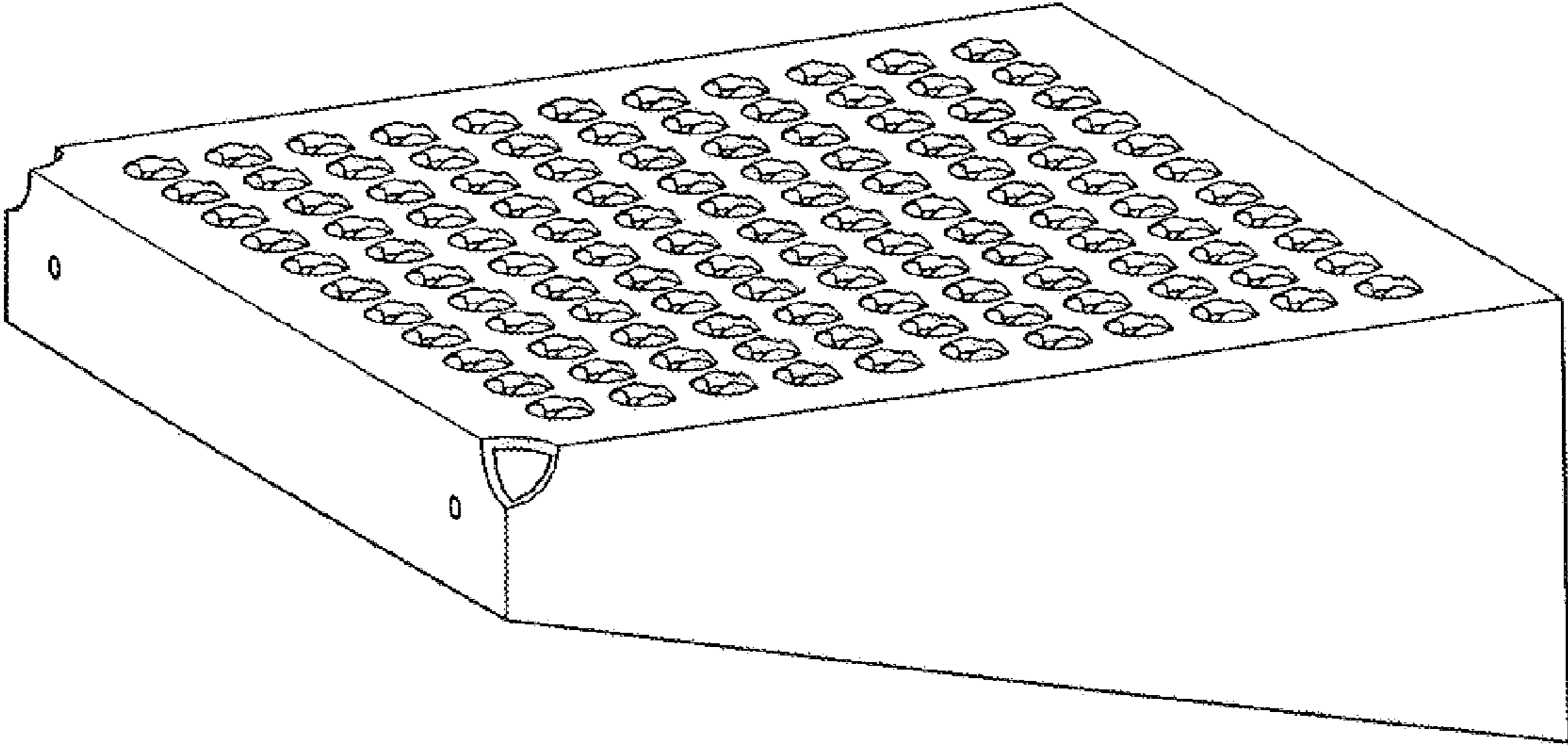

Figure 1

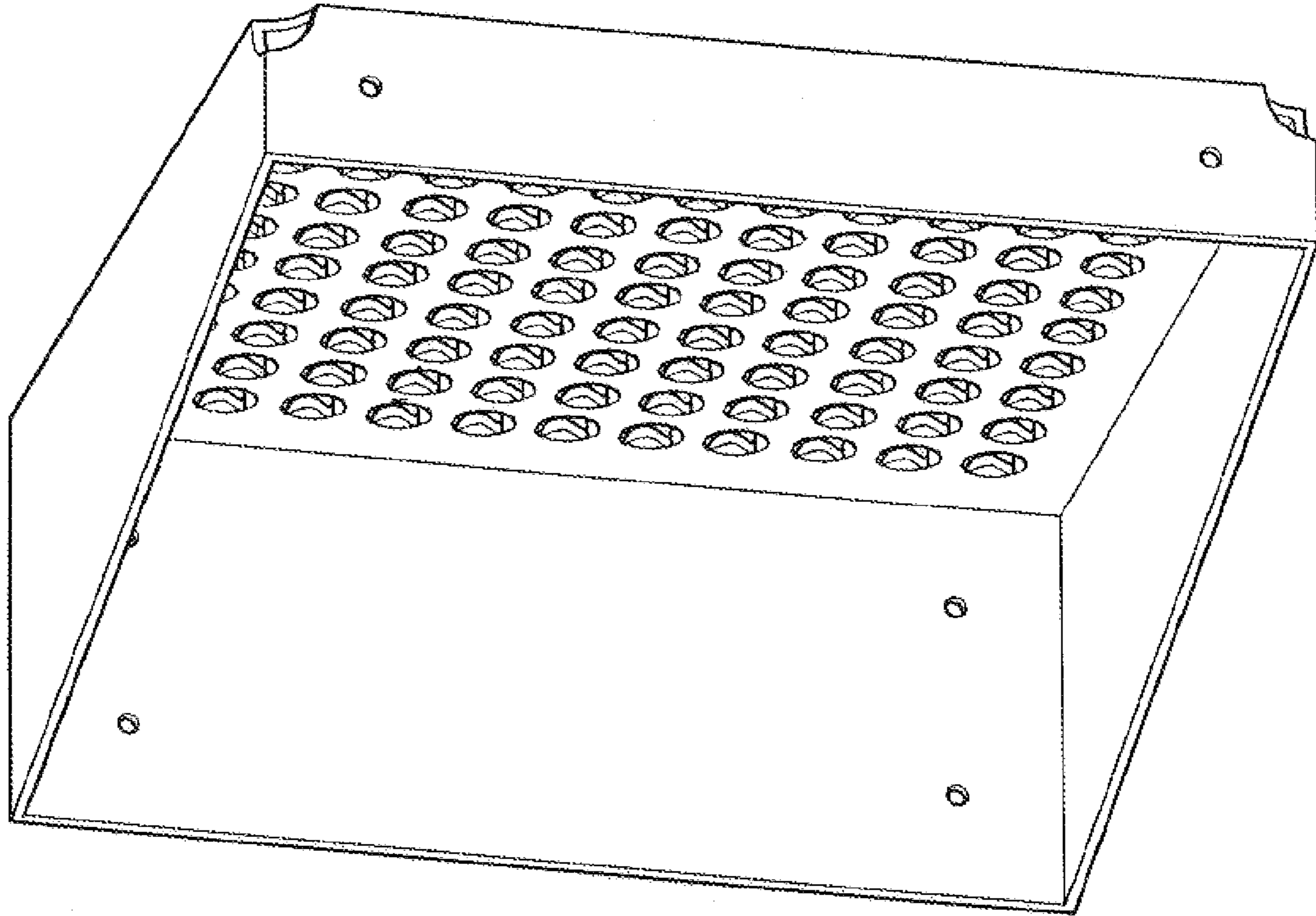

Figure 2

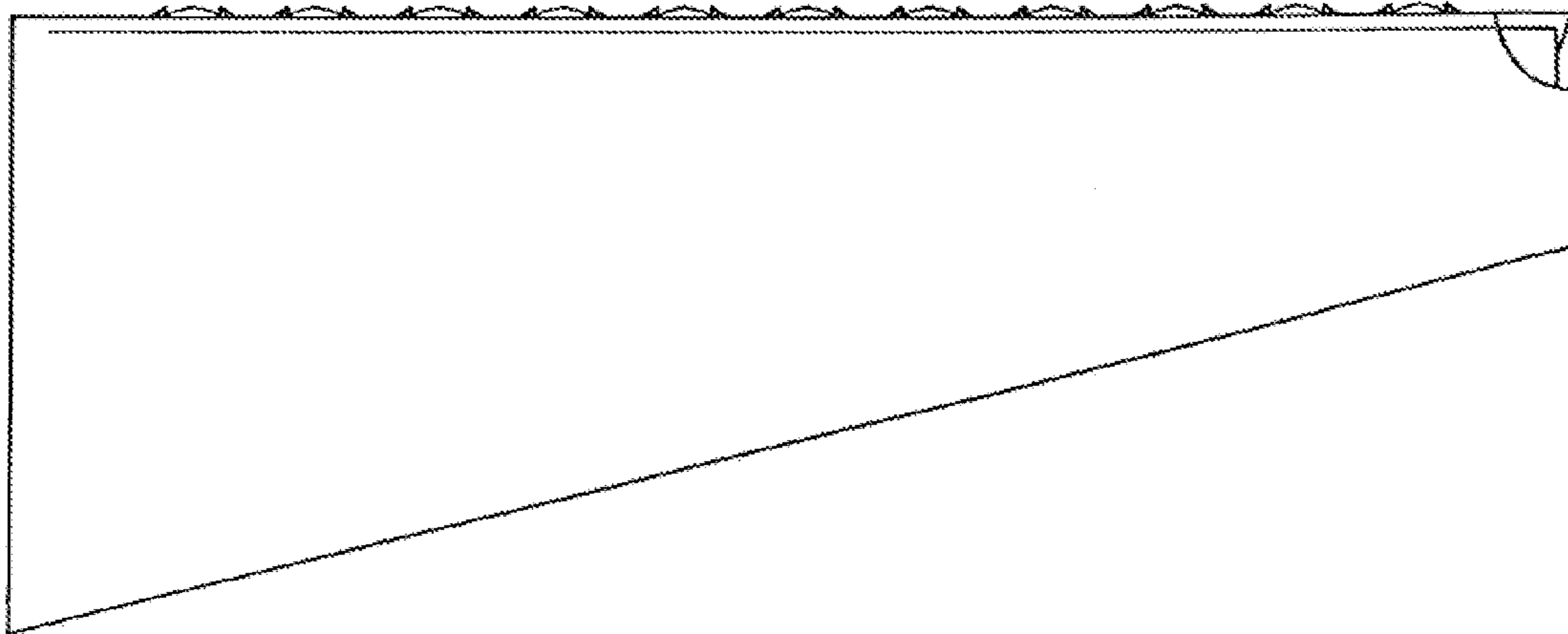

Figure 3

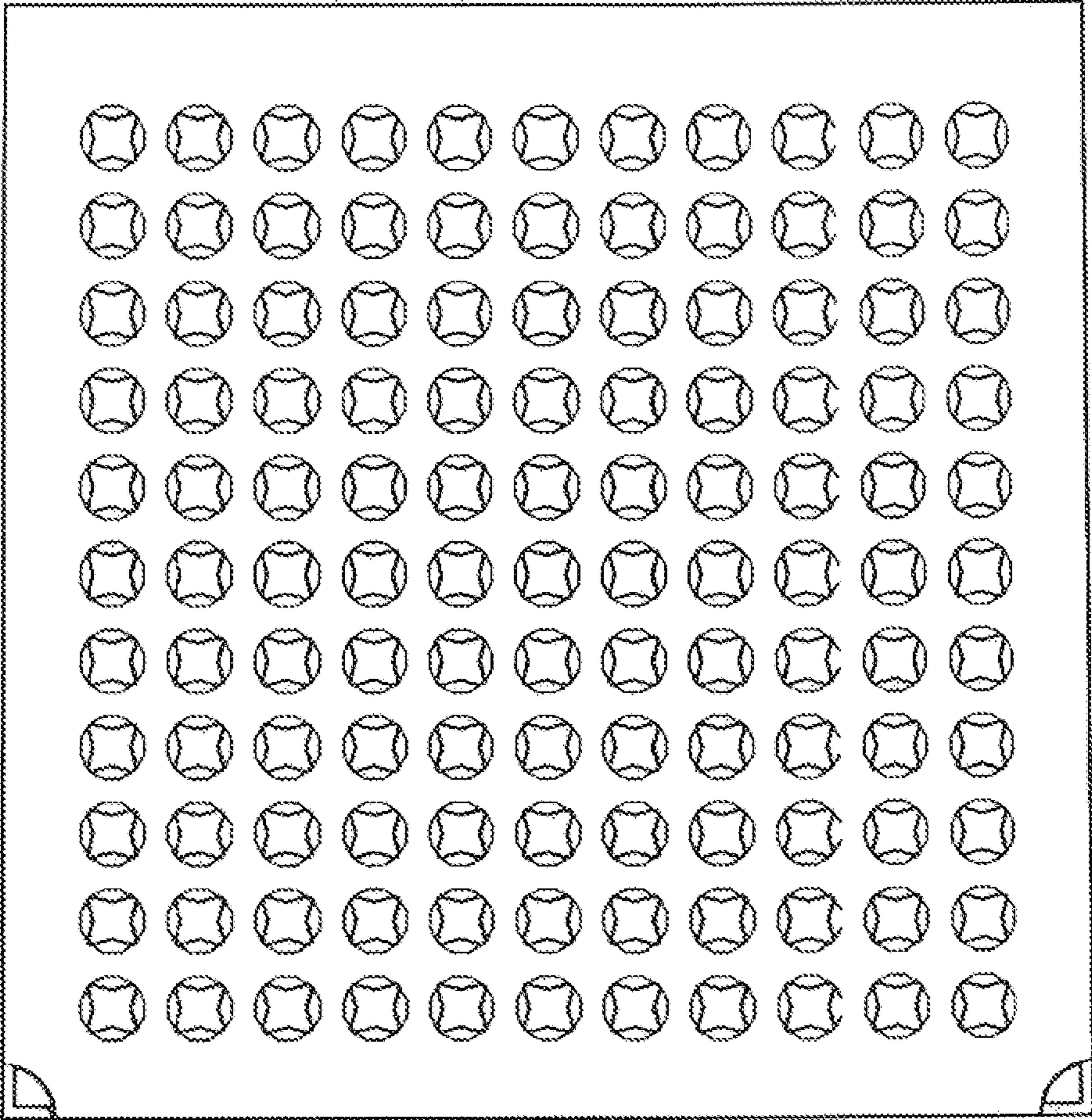

Figure 4

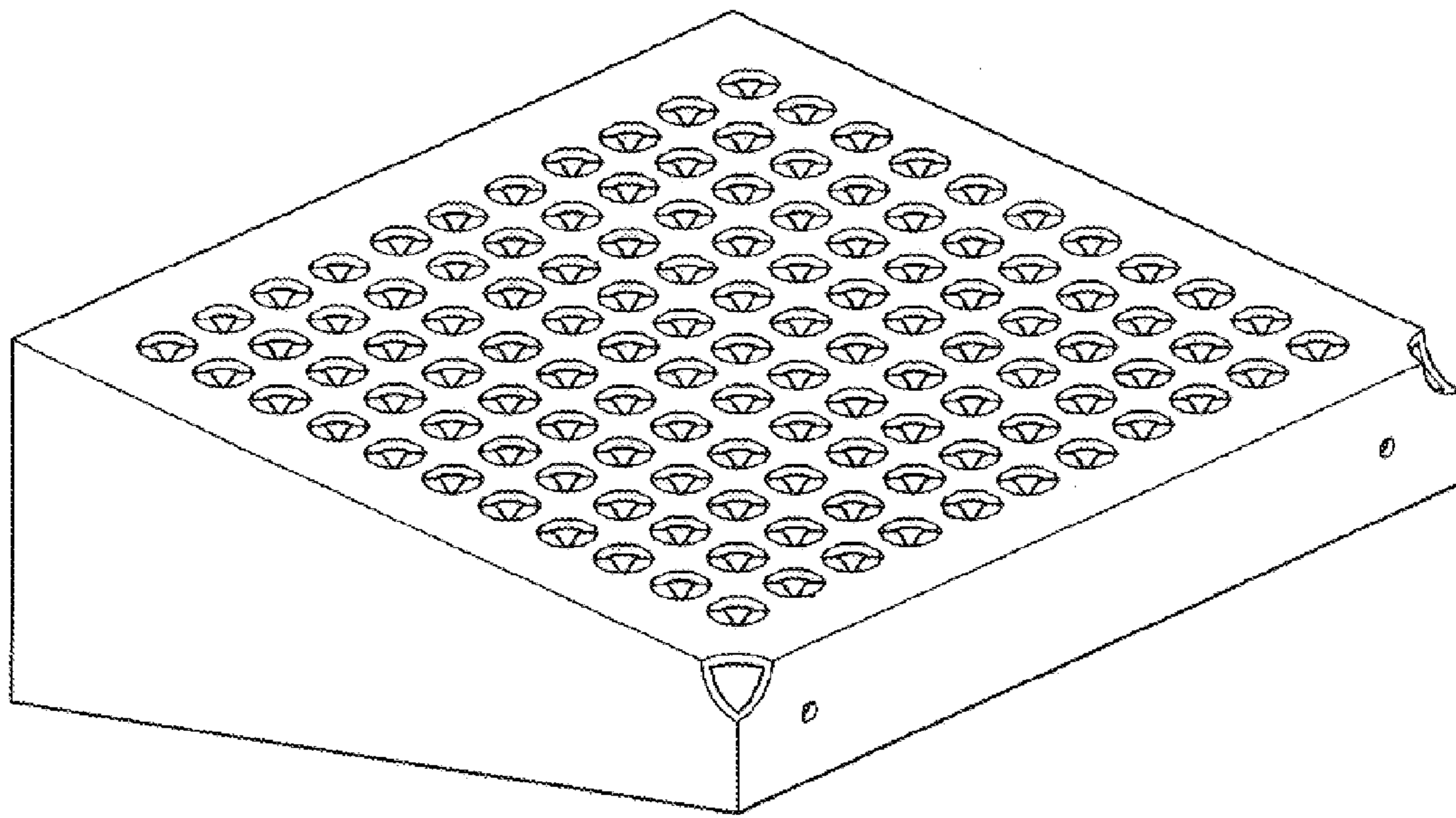

Figure 5

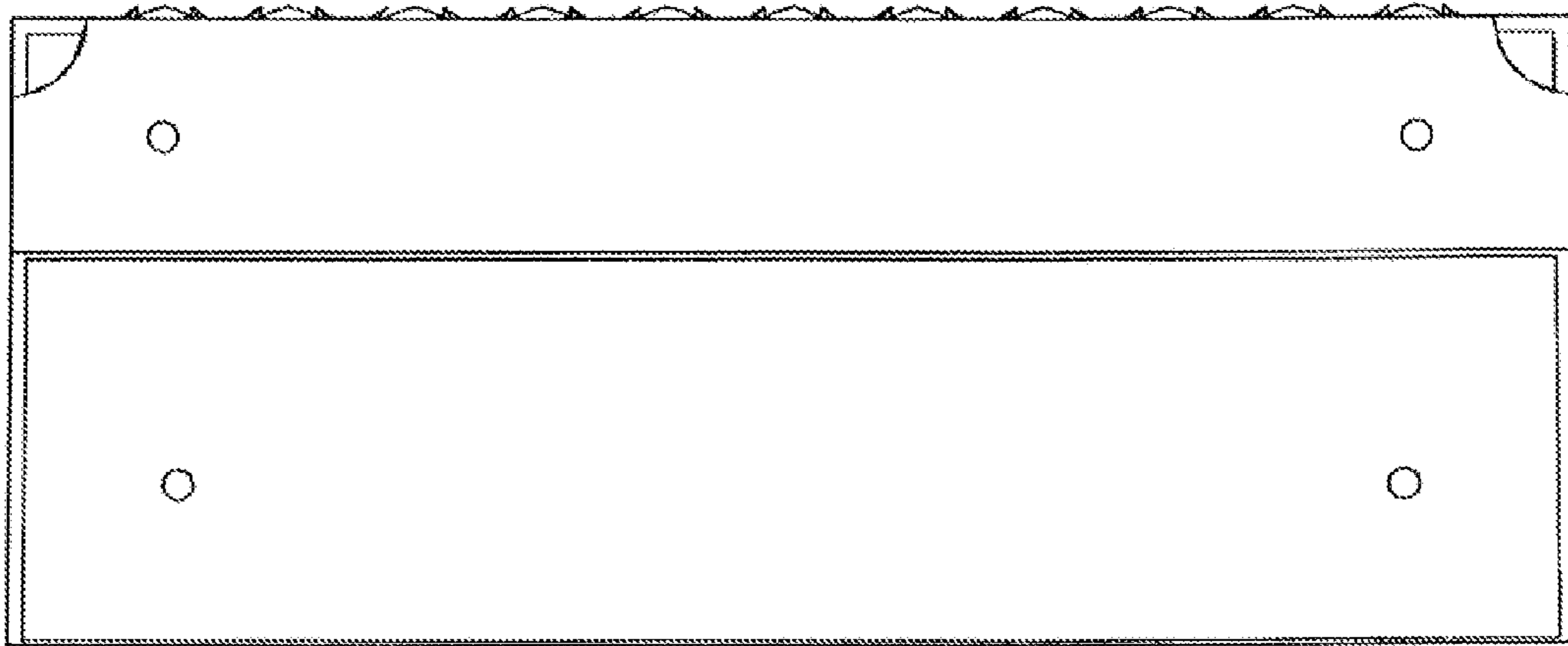

Figure 6

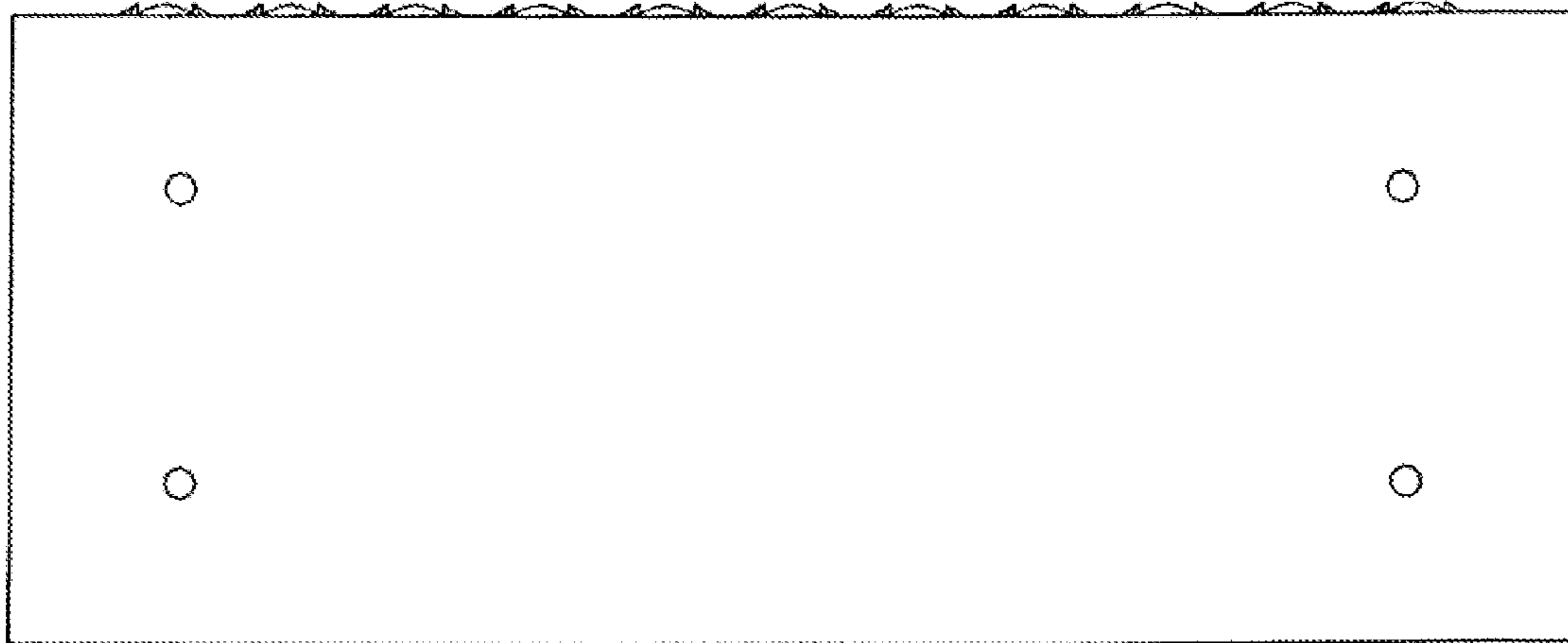

Figure 7