



US00D649432S

(12) **United States Design Patent**
Main et al.

(10) **Patent No.:** **US D649,432 S**

(45) **Date of Patent:** **** Nov. 29, 2011**

(54) **LATCH ASSEMBLY**

(75) Inventors: **Mark E. Main**, Bremen, IN (US); **Fred Buckingham**, Elkhart, IN (US); **Derrick J. Barker**, Bishampton (GB); **Ian J. Hadlow**, Worcester (GB)

(73) Assignee: **AmSafe Commercial Products, Inc.**, Elkhart, IN (US)

(**) Term: **14 Years**

(21) Appl. No.: **29/385,173**

(22) Filed: **Feb. 9, 2011**

(51) **LOC (9) Cl.** **08-07**

(52) **U.S. Cl.** **D8/331**

(58) **Field of Classification Search** D8/330,
D8/331, 339, 341, 343, 301, 302; 70/14,
70/51, 52, 69-76, 110, 111, 164, 137, 240,
70/141, DIG. 80, 241; 292/95, 129, 283,
292/300, 358, 359, DIG. 14

See application file for complete search history.

(56) **References Cited**

U.S. PATENT DOCUMENTS

5,430,914	A	7/1995	Patterson et al.
5,487,588	A	1/1996	Burleigh et al.
5,695,243	A	12/1997	Anthony et al.
6,017,087	A	1/2000	Anthony et al.
6,209,957	B1	4/2001	Baloga et al.
6,425,632	B1	7/2002	Anthony et al.
6,494,535	B2	12/2002	Galbreath
6,796,610	B2	9/2004	Nakagawa et al.
6,820,310	B2	11/2004	Woodard et al.
6,948,219	B2	9/2005	Kakuda et al.
6,962,394	B2	11/2005	Anthony et al.
7,278,684	B2	10/2007	Boyle
D610,036	S	2/2010	Balensiefer, II
7,810,220	B2	10/2010	Anthony et al.
7,862,124	B2	1/2011	Dingman
2003/0197415	A1	10/2003	Dingman
2004/0195900	A1	10/2004	The et al.
2004/0208692	A1	10/2004	Anthony et al.
2009/0241305	A1	10/2009	Buckingham

2009/0243310 A1 10/2009 Buckingham et al.
2009/0250946 A1 10/2009 Buckingham et al.
2010/0247230 A1 9/2010 Buckingham et al.

OTHER PUBLICATIONS

U.S. Appl. No. 60/394,099, filed Jul. 5, 2002, Woodard.
U.S. Appl. No. 60/307,899, filed Jul. 26, 2001, Woodard.
“SafeGuard Buckle Up With Confidence,” IMMI, 2002, 12 pages.
“Safeguard Child Protection, Seat Attachment Systems,” Brochure, IMMI, 2001, 5 pages.
“SafeGuard Child Seat Attachment Systems,” IMMI, 1999, 2 pages.
Holmbergs, Isofix—Connectors, 1 page.
Holmbergs, Isofix Connector C2, <http://www.holmbergs.se/1/1.0.1.0/47/1/> [accessed May 21, 2010], 2 pages.
International Organization for Standardization (ISO), Draft Report of the 18th meeting of WG 1 held on Nov. 10-11, 1997 in Orlando, Florida, 11 pages.
International Search Report and Written Opinion for PCT/US2009/039019; Applicant: AmSafe Commercial Products, Inc.; Mailed on May 26, 2009, 12 pages.

(Continued)

Primary Examiner — Prabhakar Deshmukh

(57) **CLAIM**

The ornamental design for a latch assembly, as shown and described.

DESCRIPTION

FIG. 1 is a first perspective view of a latch assembly showing our design.
FIG. 2 is a second perspective view thereof.
FIG. 3 is a front view thereof.
FIG. 4 is a back view thereof.
FIG. 5 is a left view thereof.
FIG. 6 is a right view thereof.
FIG. 7 is a top view thereof; and,
FIG. 8 is a bottom view thereof.
The broken lines are directed to environment and are for illustrative purposes only. The broken lines form no part of the claimed design.

1 Claim, 3 Drawing Sheets

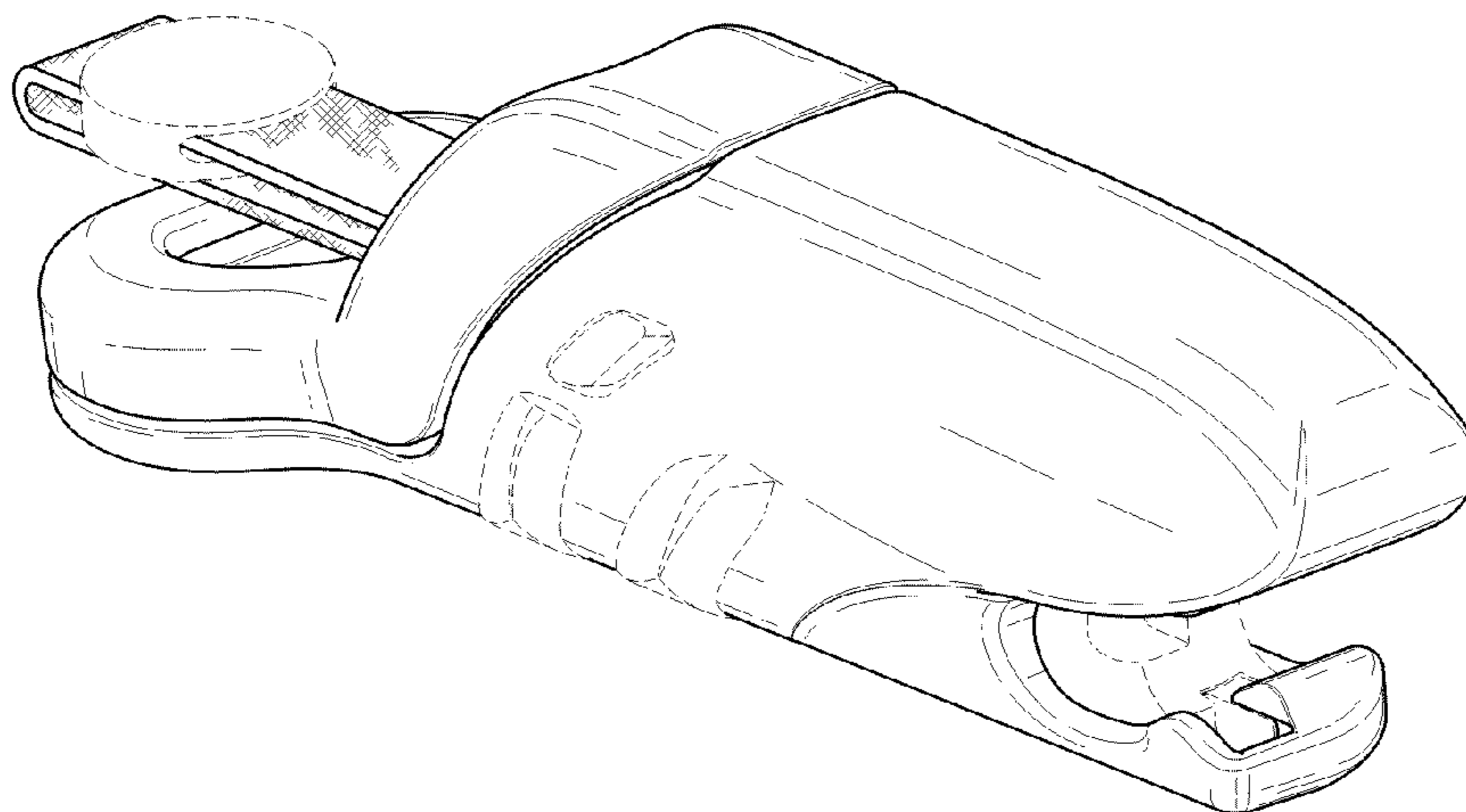

OTHER PUBLICATIONS

International Search Report and Written Opinion for PCT/US2009/047559; Applicant: AmSafe Commercial Products, Inc.; Mailed on Aug. 7, 2009, 10 pages.

International Search Report and Written Opinion for PCT/US2010/034933; Applicant: AmSafe Commercial Products, Inc.; Mailed on Jul. 16, 2010, 11 pages.

Non-Final Office Action; U.S. Appl. No. 12/060,095, Mailing Date Dec. 27, 2010, 20 pages.

Novarace, EU Isofix, http://www.novarace.com/index.php?option=com_content&task=view&id=42&Itemid=62 [accessed May 21, 2010], 1 page.

Novarace, Novafix, http://www.novarace.com/index.php?option=com_content&task=view&id=43&Itemid=51 [accessed May 21, 2010]. 1 page.

Sabelt Racing Seatbelts and Accessories, <http://childsafety.sabelt.com/index.php/eshop/category/Sabelt-Racing-Seatbelts-and-Accessories.html?a=/1/frmCatID/290/> [accessed May 21, 2010], 3 pages.

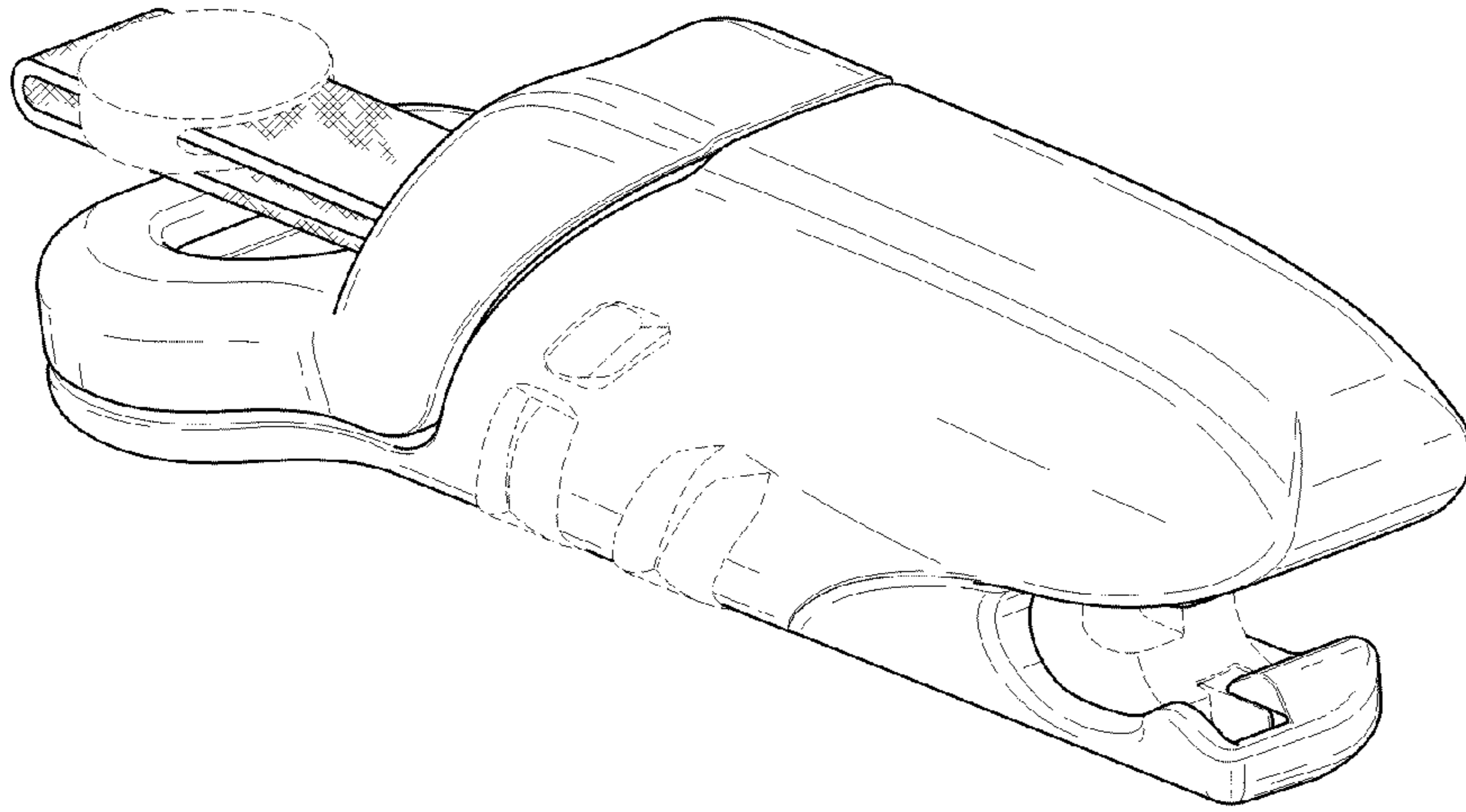

Fig. 1

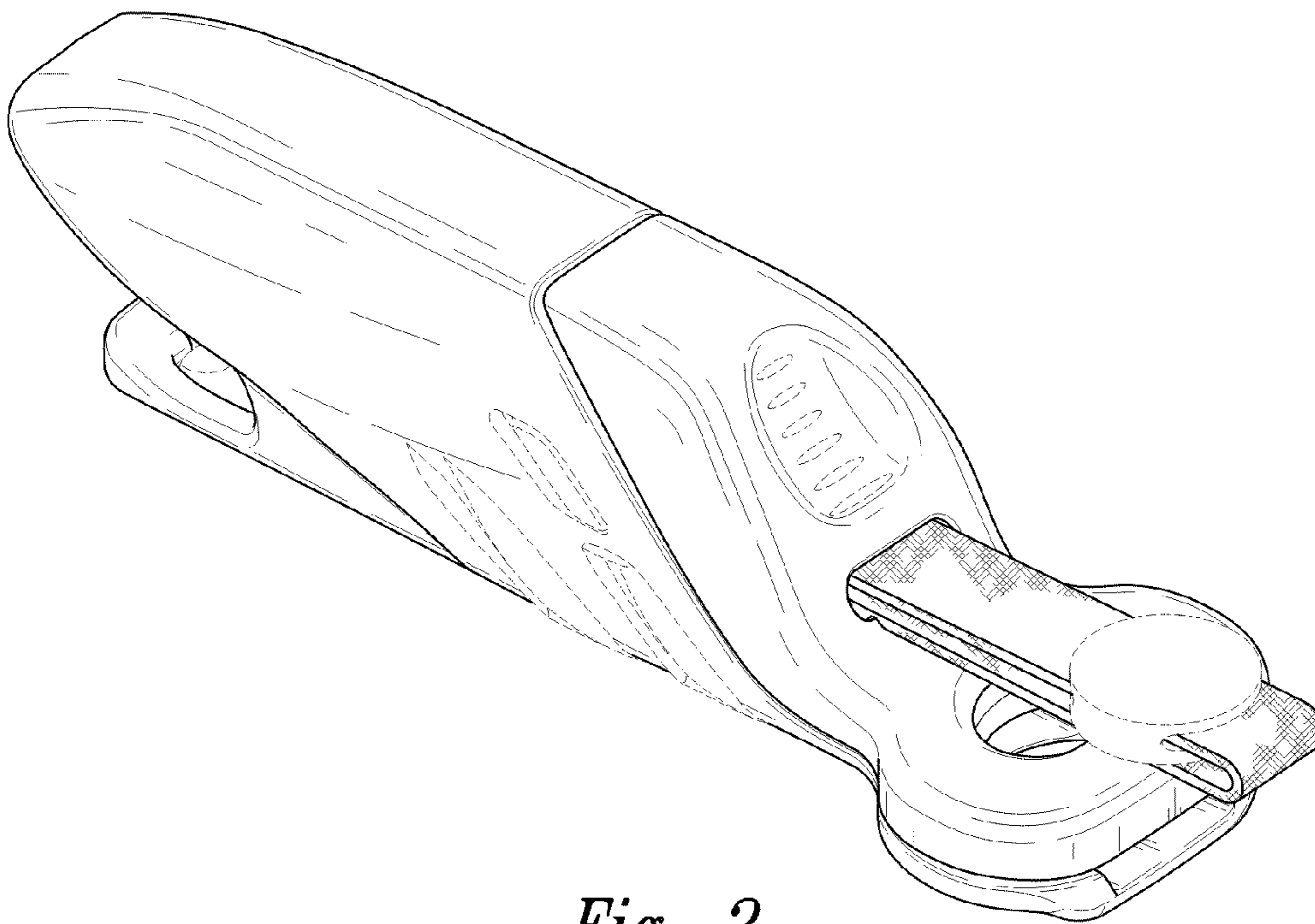

Fig. 2

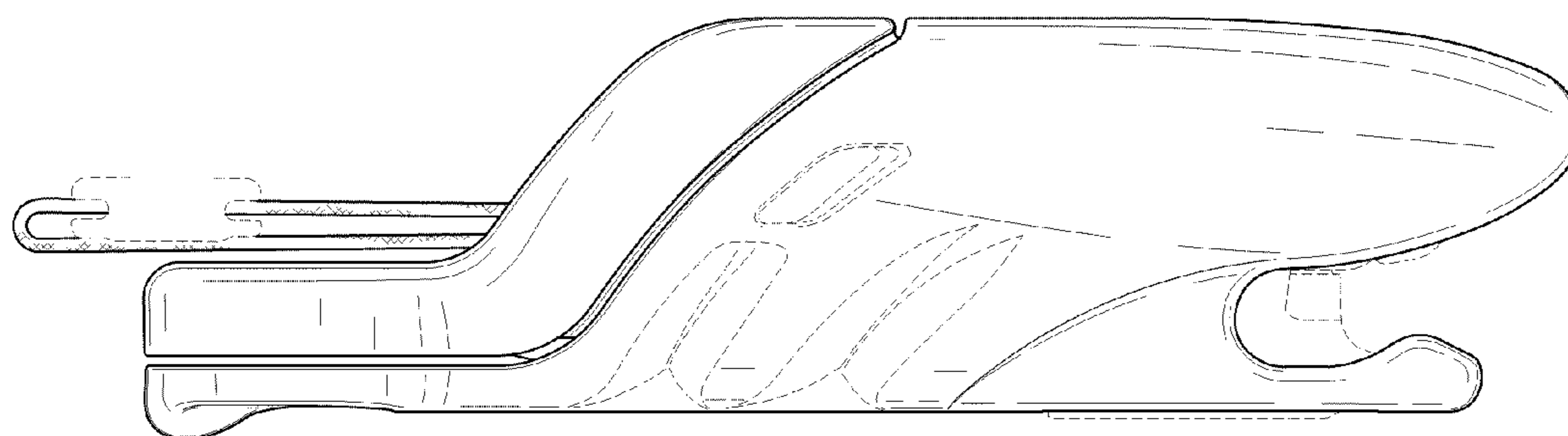

Fig. 3

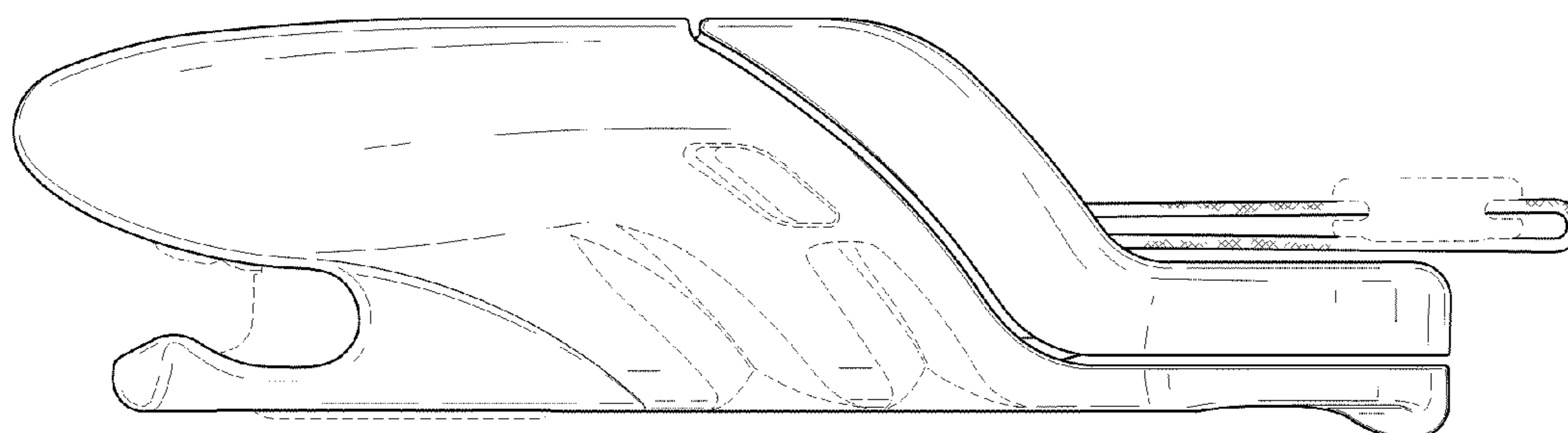

Fig. 4

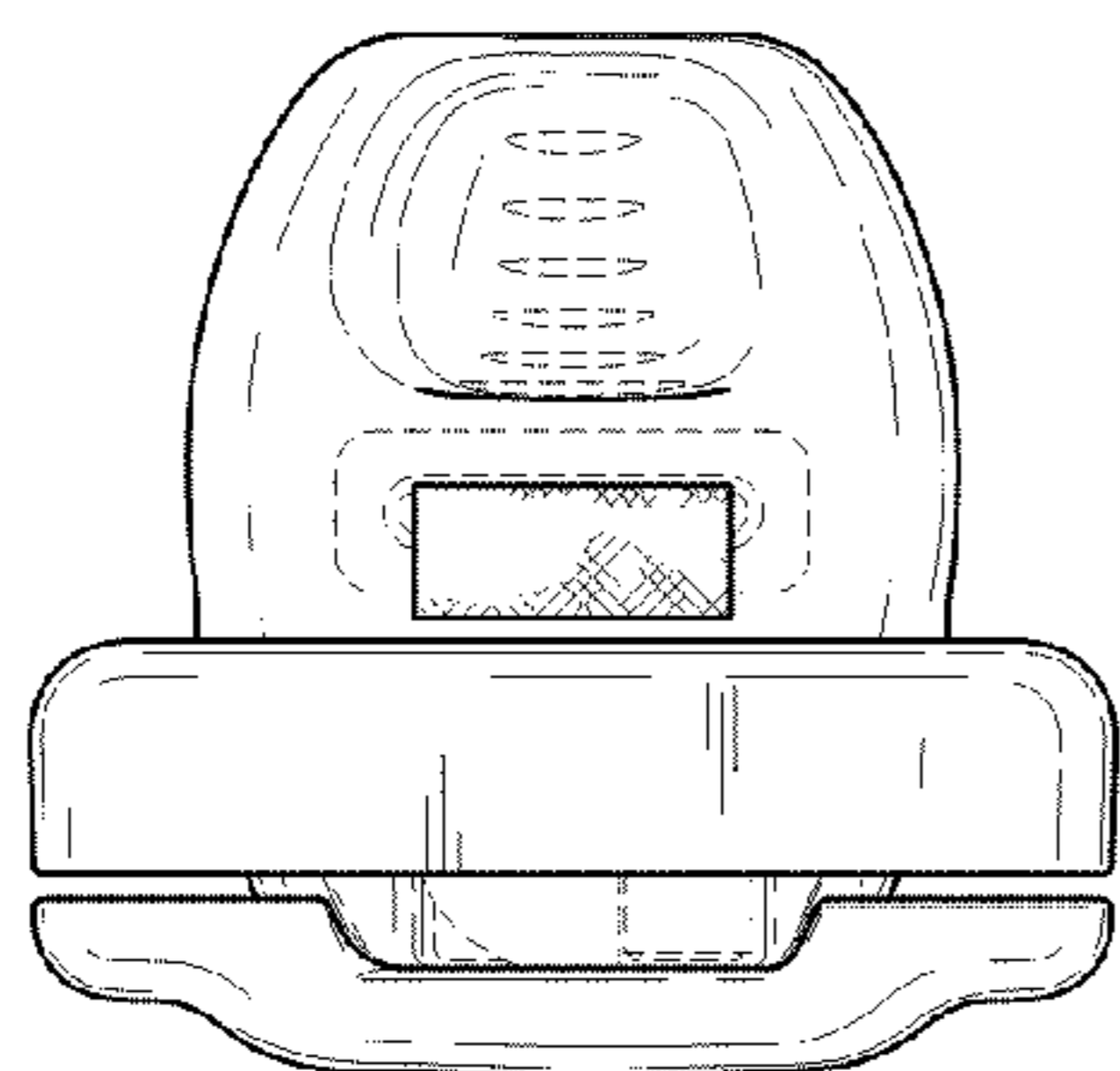

Fig. 5

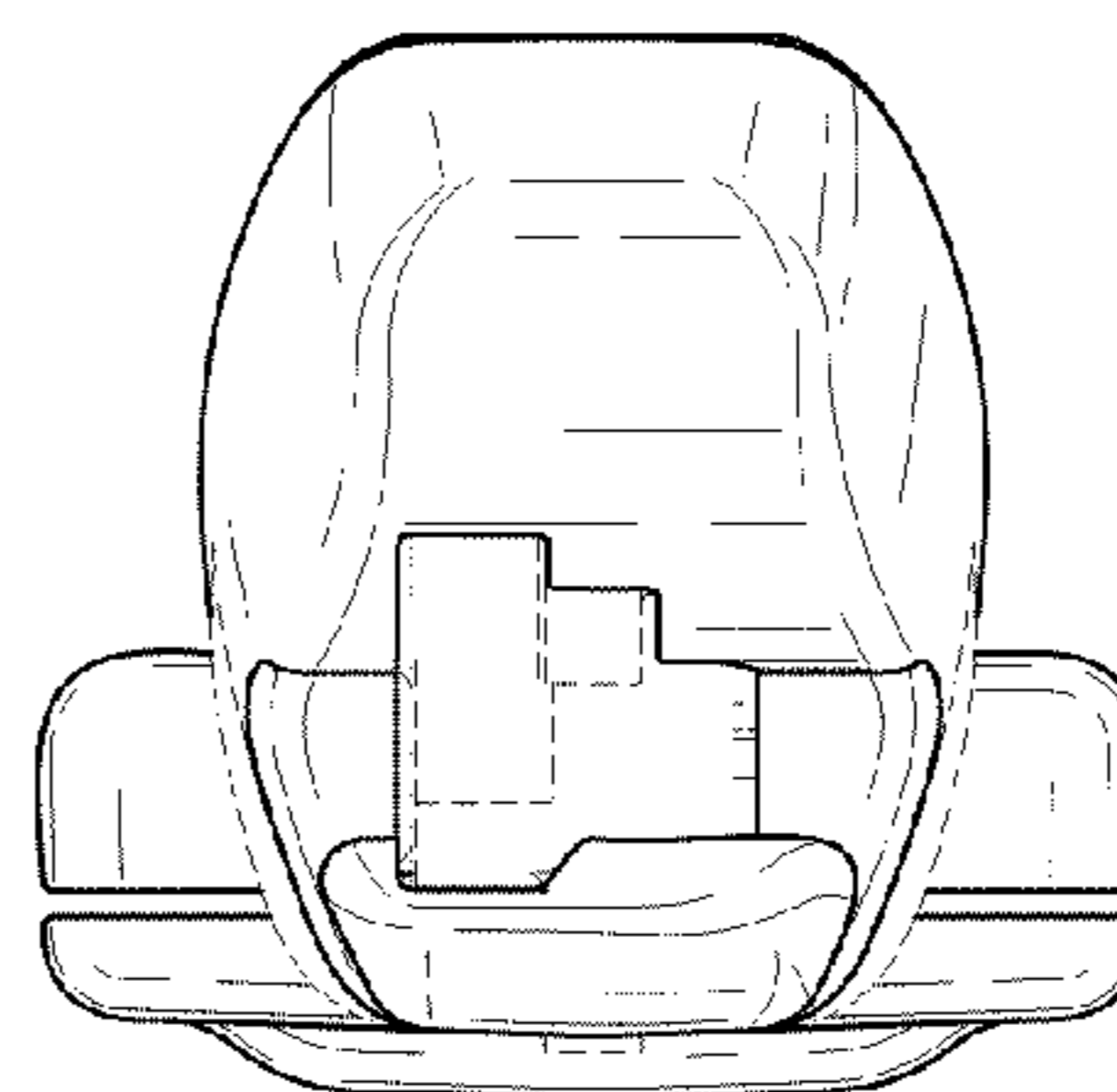

Fig. 6

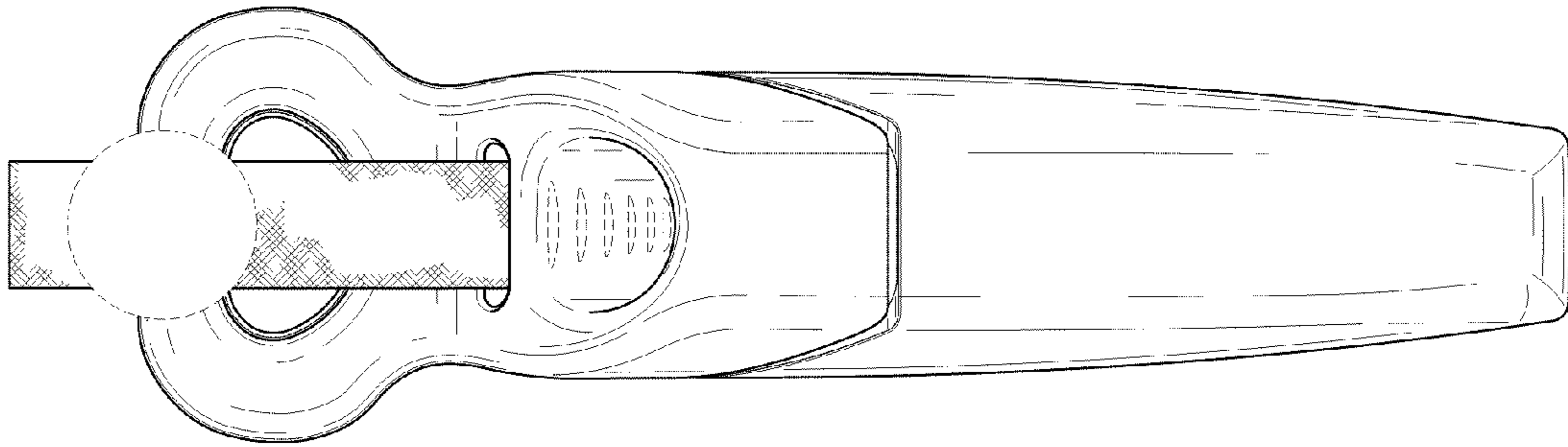

Fig. 7

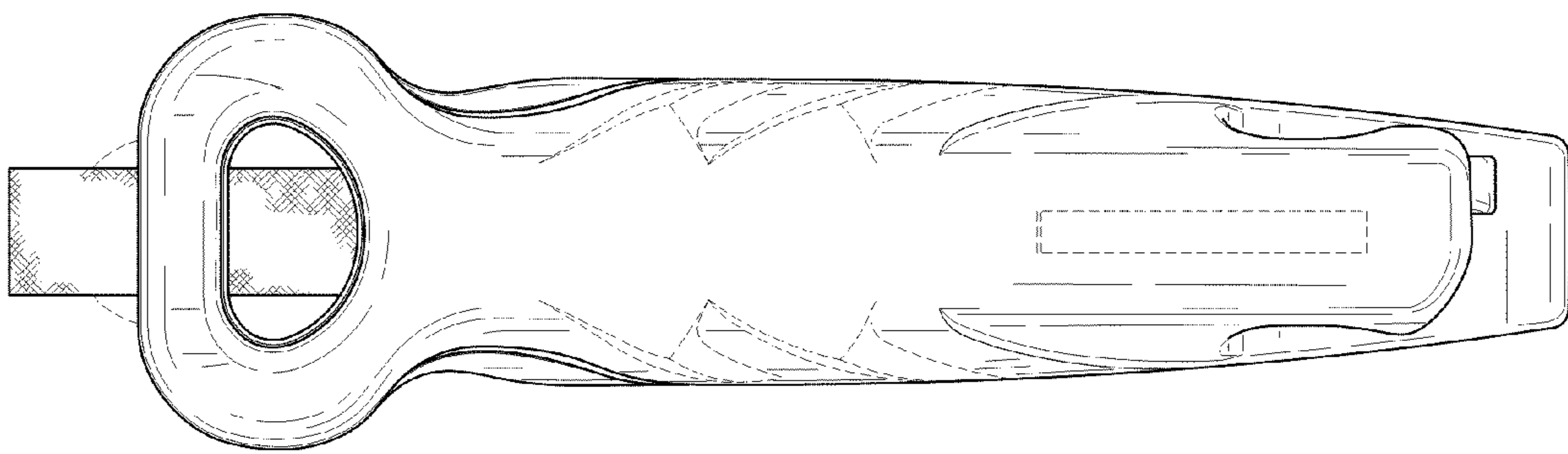

Fig. 8