



US00D649104S

(12) **United States Design Patent**
Gallert

(10) **Patent No.:** **US D649,104 S**

(45) **Date of Patent:** **** Nov. 22, 2011**

(54) **AUTOMOBILE WHEEL**

(75) Inventor: **Michael Gallert**, Stuttgart (DE)

(73) Assignee: **Dr. Ing. h.c. F. Porsche**
Aktiengesellschaft, Stuttgart (DE)

(**) Term: **14 Years**

(21) Appl. No.: **29/338,944**

(22) Filed: **Jun. 22, 2009**

(51) **LOC (9) Cl.** **12-16**

(52) **U.S. Cl.** **D12/211**

(58) **Field of Classification Search** D12/204-213;
301/37.101, 64.101, 65, 64.201

See application file for complete search history.

(56) **References Cited**

U.S. PATENT DOCUMENTS

D410,618 S *	6/1999	Hussaini et al.	D12/211
D451,876 S *	12/2001	Kohl	D12/211
D481,663 S *	11/2003	Maifrini	D12/211
D491,872 S *	6/2004	Lai	D12/211

D515,003 S *	2/2006	Echazabal	D12/211
D542,211 S *	5/2007	Hieke	D12/211
D544,823 S *	6/2007	Hieke	D12/211
D596,549 S *	7/2009	Varga	D12/211
D603,779 S *	11/2009	Futschik et al.	D12/211
D609,623 S *	2/2010	Gallert	D12/209
D614,108 S *	4/2010	Varga	D12/211
D636,716 S *	4/2011	Ettensberger	D12/211

* cited by examiner

Primary Examiner — Stacia Cadmus

(57) **CLAIM**

The ornamental design for an automobile wheel, as shown and described.

DESCRIPTION

FIG. 1 is a front elevational view of an automobile wheel, showing my new design; and,

FIG. 2 is a perspective view thereof.

The broken line showing of the rear portion of the wheel is included for the purpose of illustrating environment and forms no part of the claimed design.

1 Claim, 2 Drawing Sheets

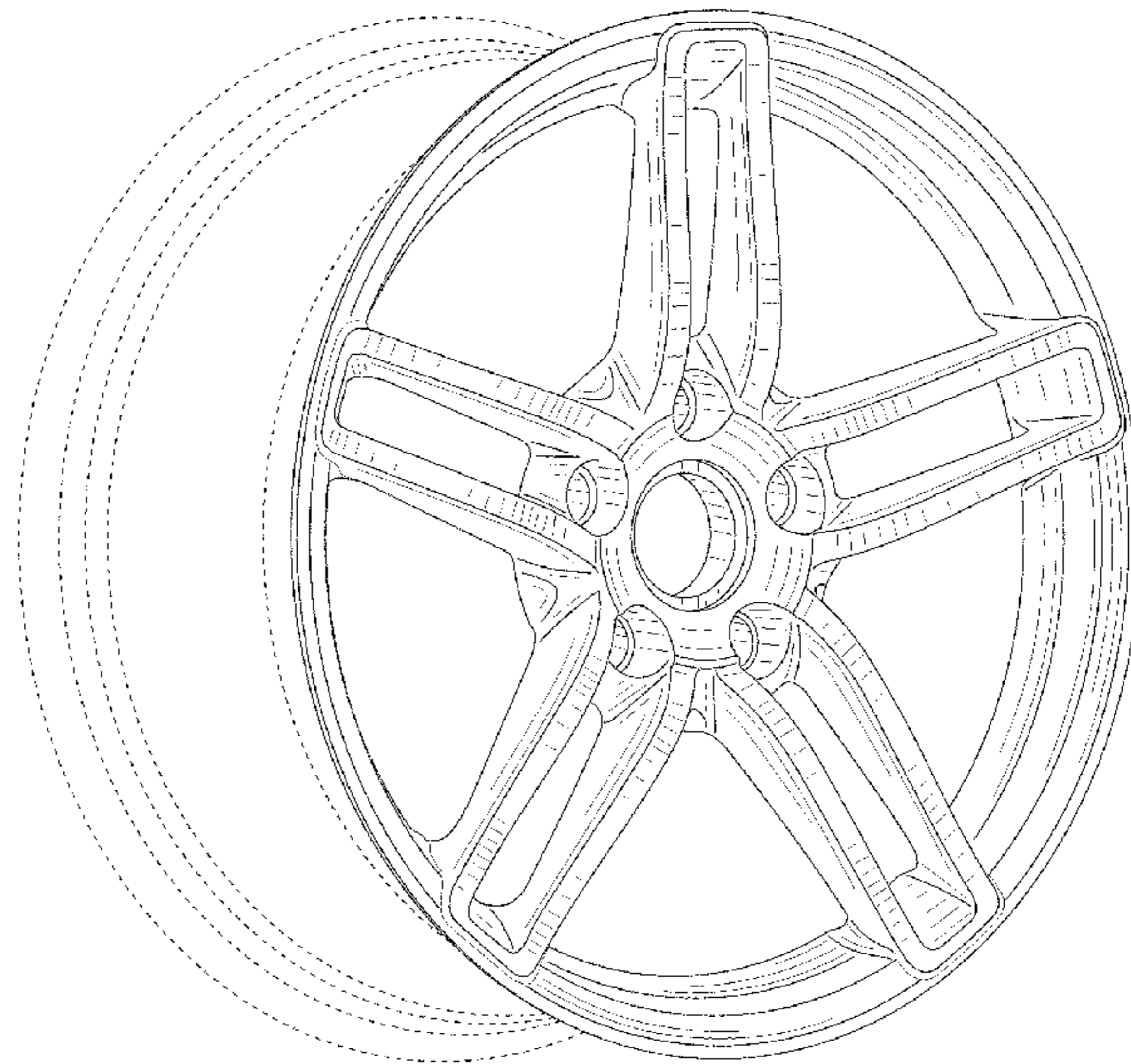
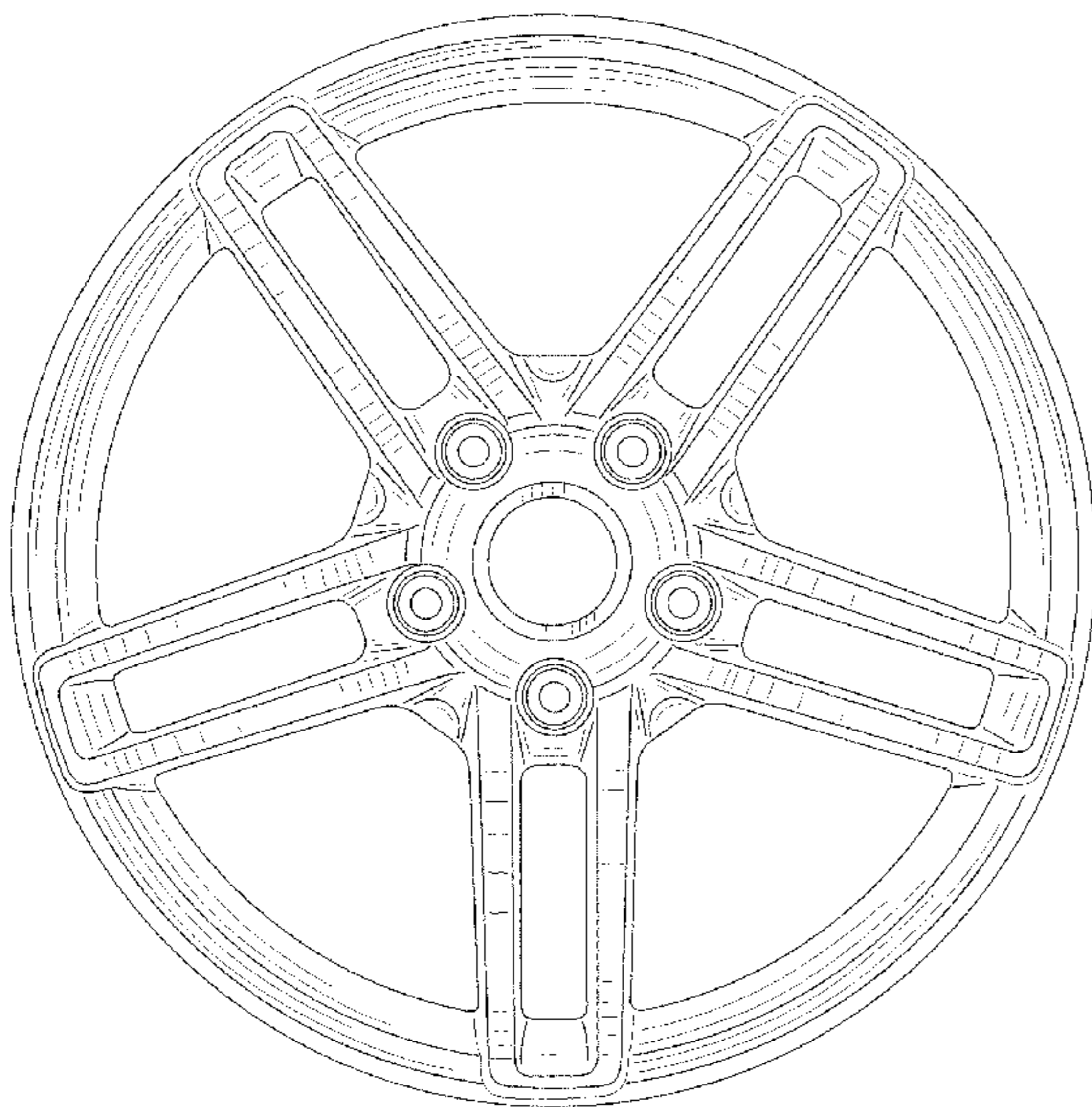

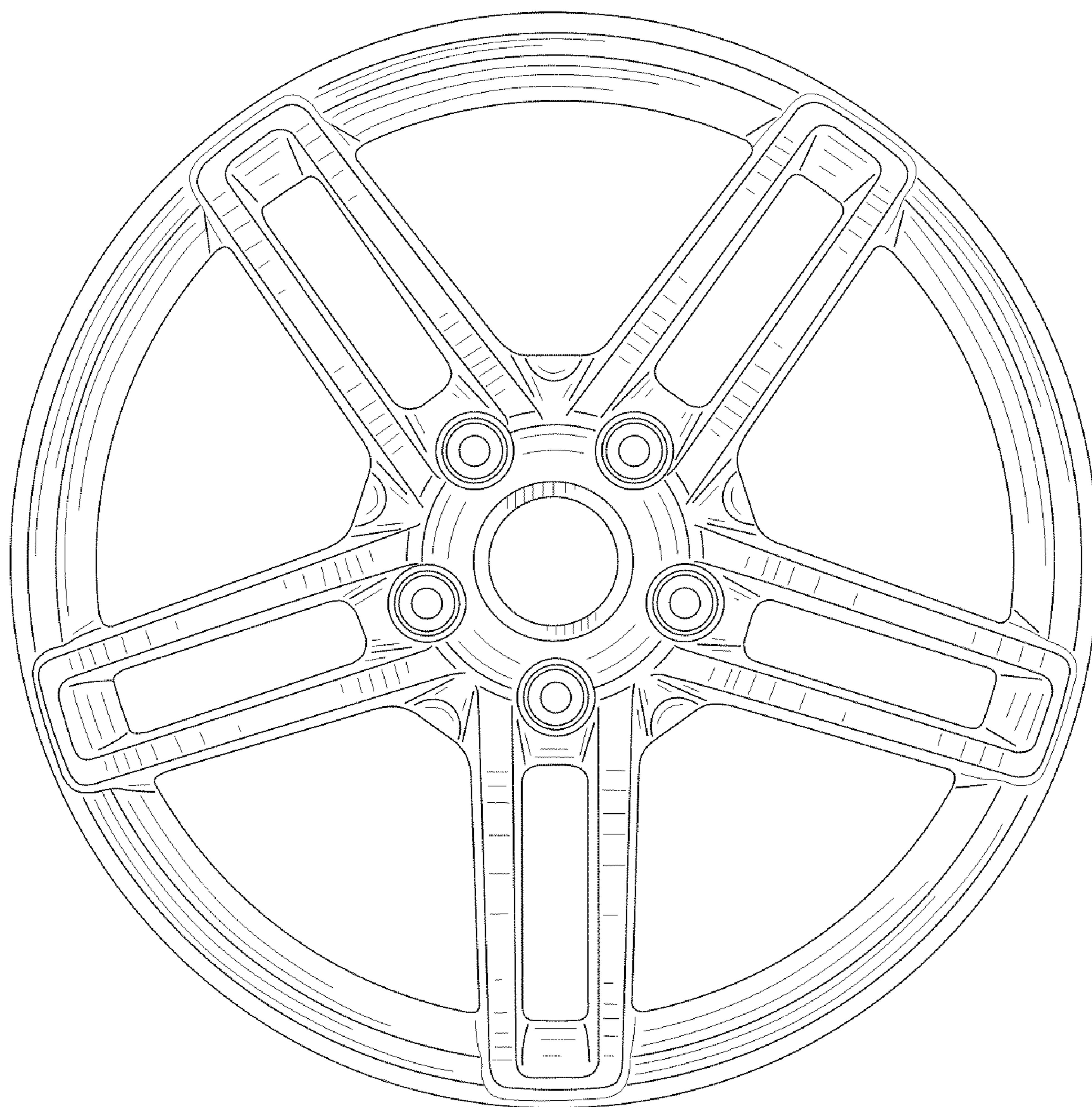

FIG. 1

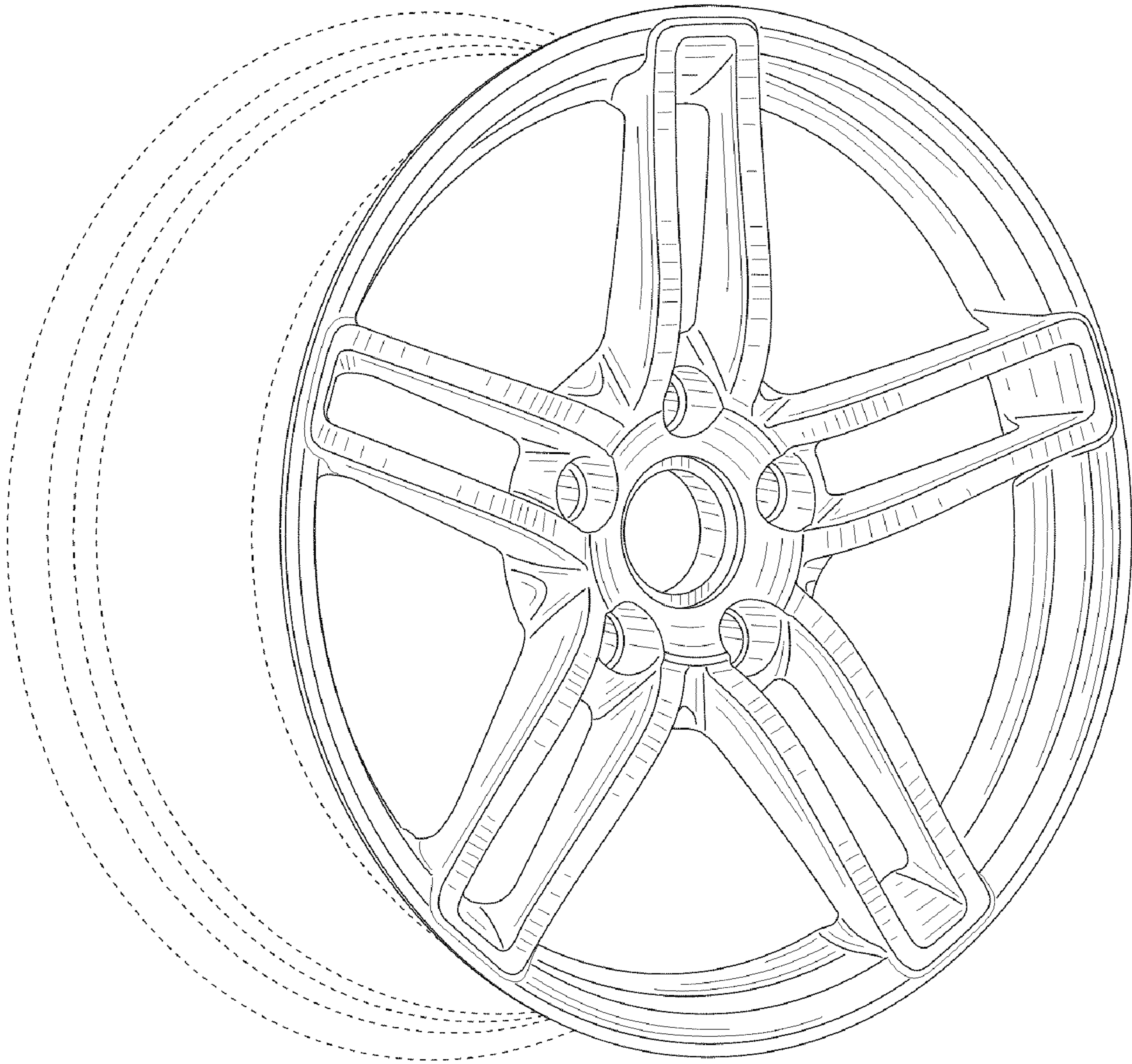

FIG. 2