



US00D648959S

(12) **United States Design Patent**  
**Alden**

(10) **Patent No.:** **US D648,959 S**

(45) **Date of Patent:** **\*\* Nov. 22, 2011**

(54) **DISPLAY AND SALES UNIT**

(75) **Inventor:** **Kurt Alden, Aby (SE)**

(73) **Assignee:** **Design Force AB, Norrkoping (SE)**

(\*\*) **Term:** **14 Years**

(21) **Appl. No.:** **29/388,447**

(22) **Filed:** **Mar. 29, 2011**

(30) **Foreign Application Priority Data**

Oct. 25, 2010 (EM) ..... 001772286-0001

(51) **LOC (9) Cl.** ..... **06-04**

(52) **U.S. Cl.** ..... **D6/468**

(58) **Field of Classification Search** ..... D6/396,  
D6/408, 409, 449, 450, 454-469; 211/1,  
211/10, 13.1, 27, 50-53, 59.2, 59.3, 70, 70.1,  
211/85.2, 104, 135, 149; D9/414, 432, 433,  
D9/456; D22/120, 122; D23/366; D26/9;  
40/124.14, 124.19, 538-540; 248/174; 229/102.5,  
229/103.3, 104; 439/83

See application file for complete search history.

(56) **References Cited**

**U.S. PATENT DOCUMENTS**

1,723,944 A \* 8/1929 Marsh ..... 248/174  
D270,267 S \* 8/1983 Stout ..... D22/122  
D276,253 S \* 11/1984 Stout ..... D22/120

D313,557 S \* 1/1991 Straub et al. .... D9/432  
5,316,154 A \* 5/1994 Hajec, Jr. .... 211/59.2  
5,322,167 A \* 6/1994 Birutis et al. .... 211/50  
5,588,848 A \* 12/1996 Law et al. .... 439/83  
5,862,980 A \* 1/1999 Samuelson ..... 229/104  
6,098,818 A \* 8/2000 Ali et al. .... 211/50  
D552,879 S \* 10/2007 Phan ..... D6/449  
D600,944 S \* 9/2009 McConnell et al. .... D6/449  
7,954,655 B2 \* 6/2011 Virvo ..... 211/149  
2003/0226811 A1 \* 12/2003 Riga ..... 211/13.1

\* cited by examiner

*Primary Examiner* — Mary Ann Calabrese

(74) *Attorney, Agent, or Firm* — Greer, Burns & Crain, Ltd.

(57) **CLAIM**

The ornamental design for a display and sales unit, as shown and described.

**DESCRIPTION**

FIG. 1 is a perspective view of the display and sales unit showing my new design in an assembled configuration.

FIG. 2 is a top plan view thereof.

FIG. 3 is an exterior elevational view of the Display and Sales Unit in an unfolded configuration.

FIG. 4 is an interior elevational view thereof in the unfolded configuration.

FIG. 5 is a top plan view thereof in the unfolded configuration; and,

FIG. 6 is a bottom plan view thereof in the unfolded configuration.

**1 Claim, 2 Drawing Sheets**

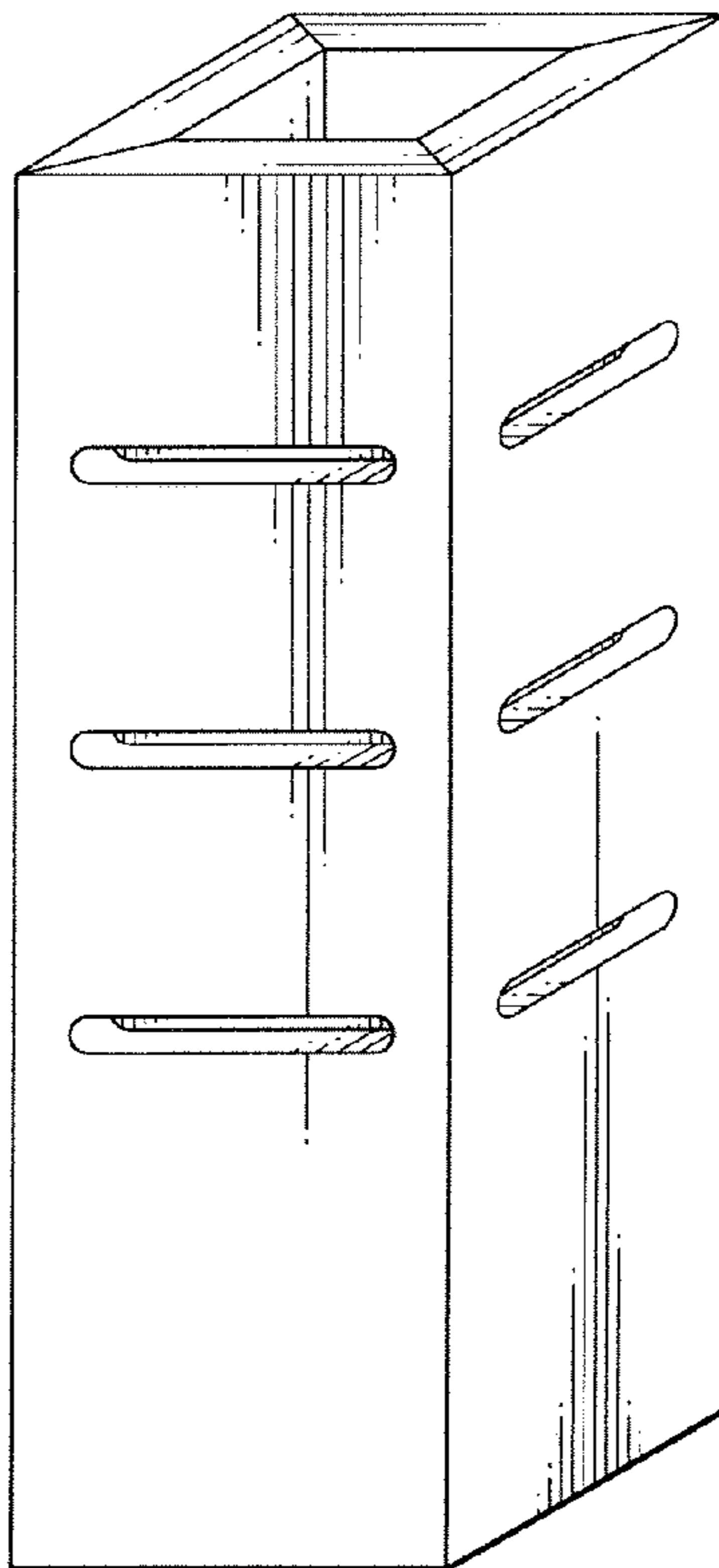

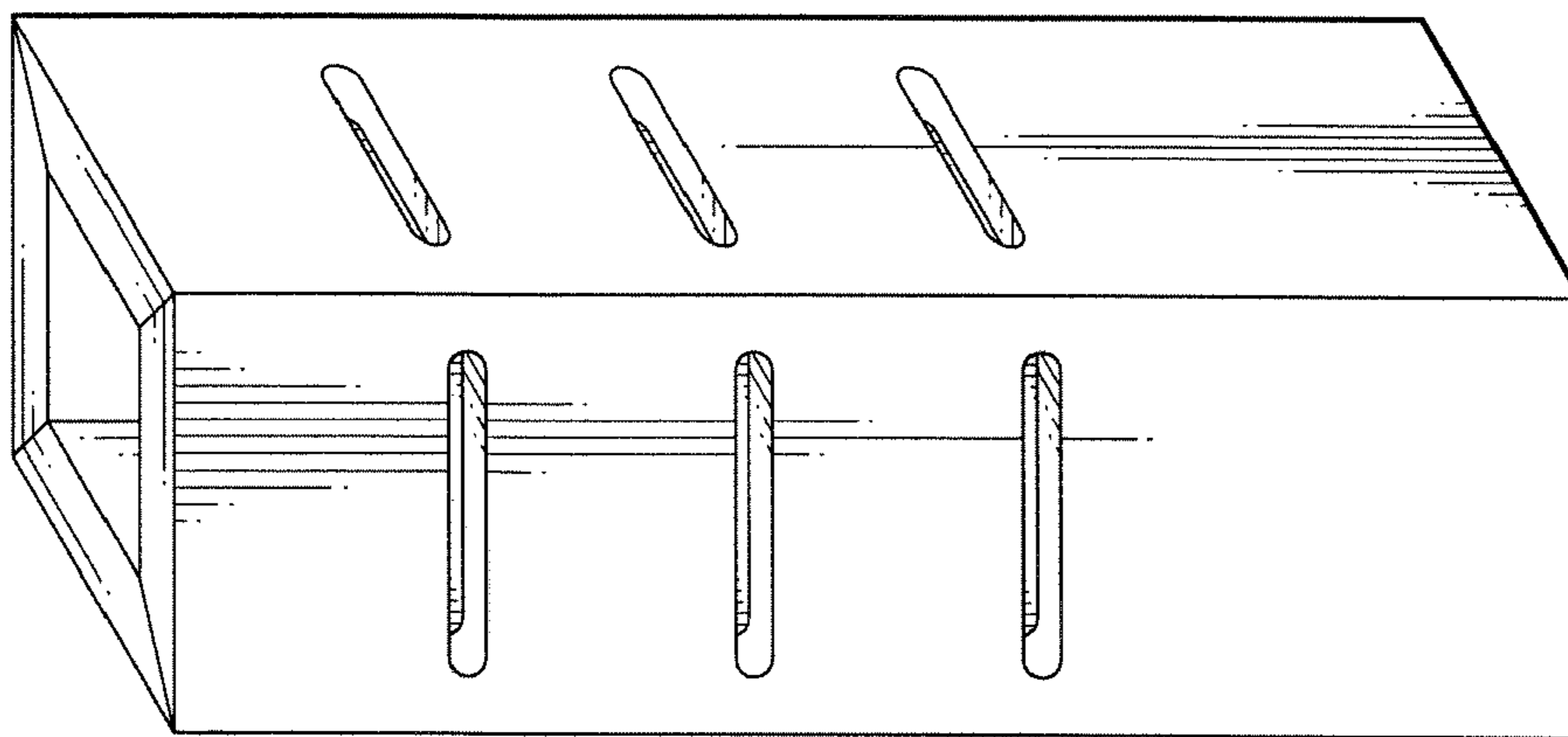

FIG. 1

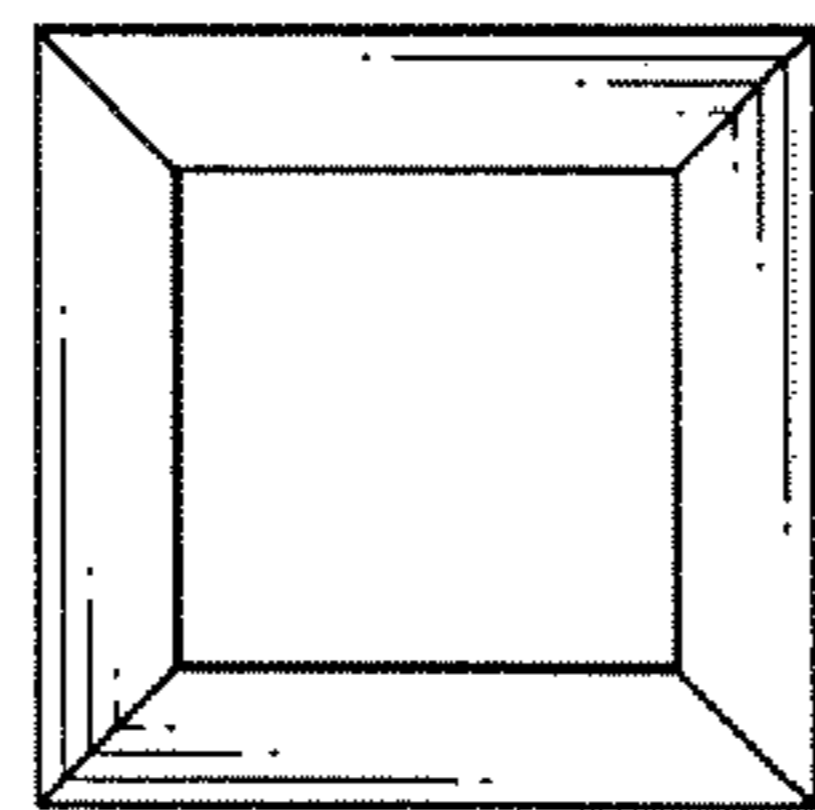

FIG. 2

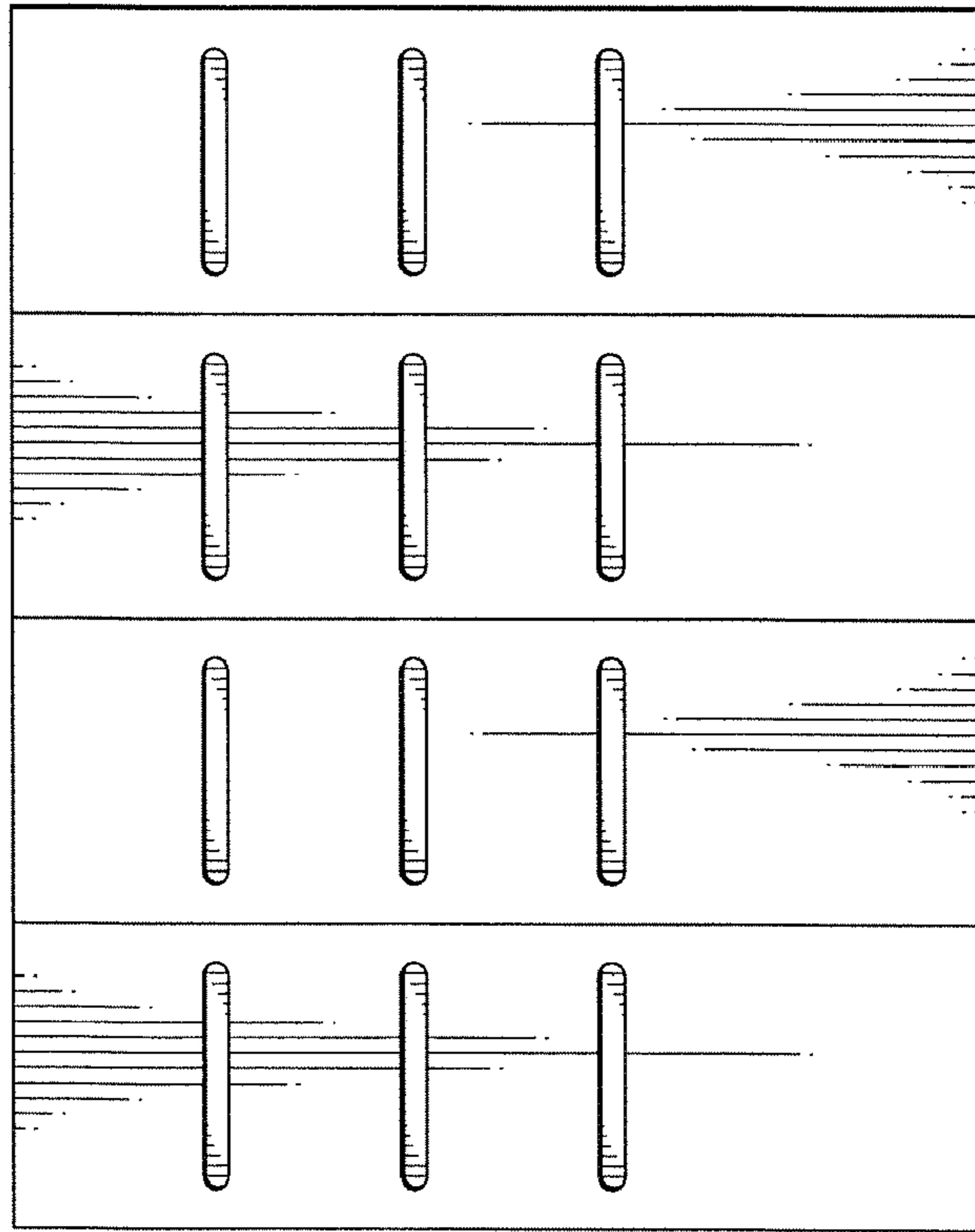

FIG. 3

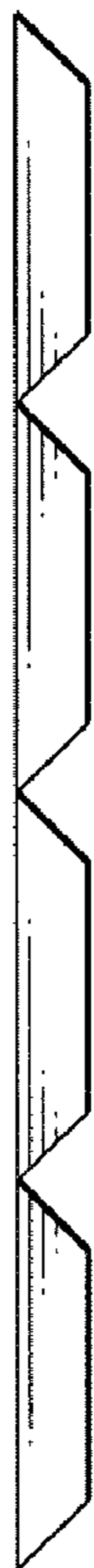

FIG. 5



FIG. 6

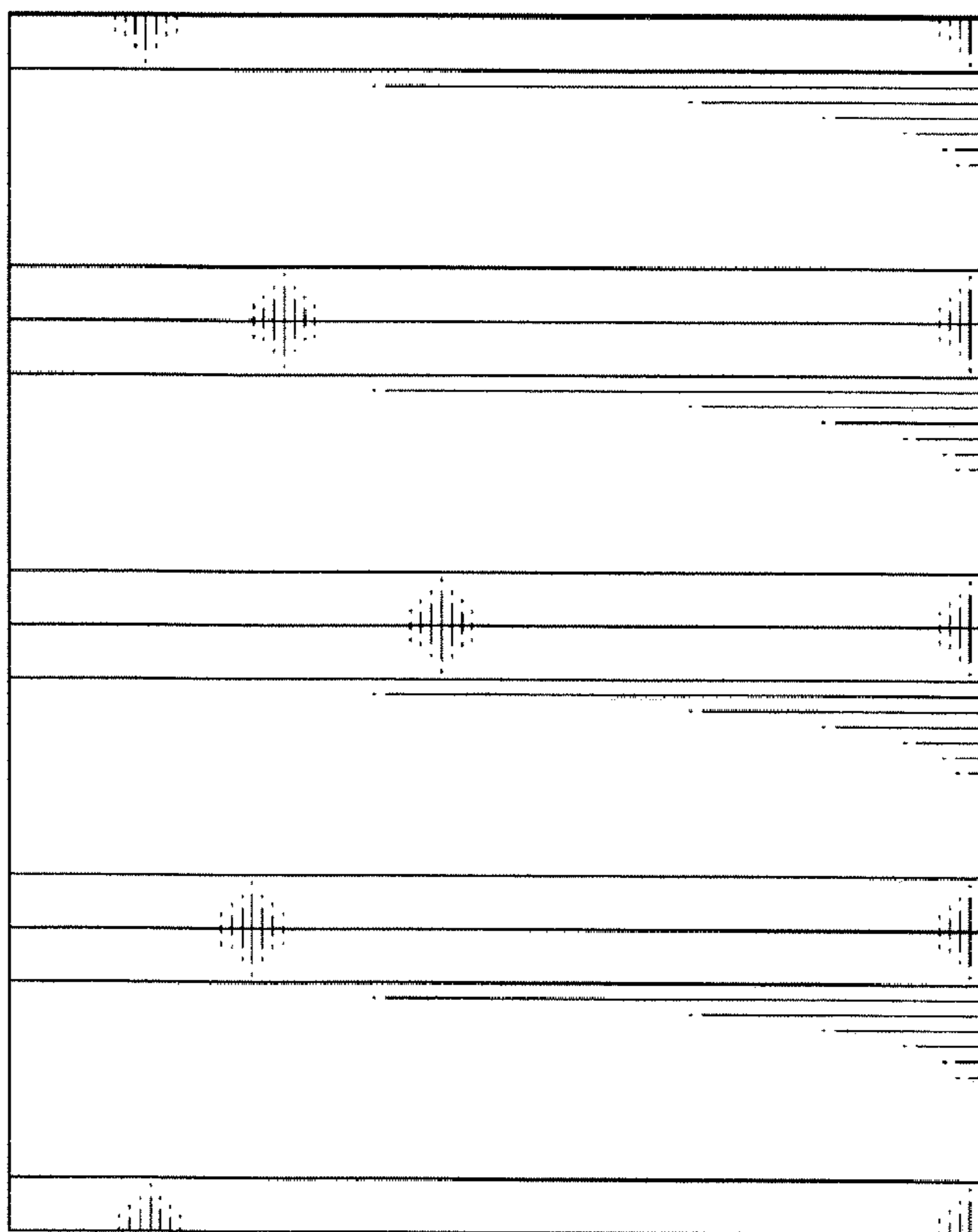

FIG. 4