



US00D648792S

(12) **United States Design Patent**  
**Li**

(10) **Patent No.:** **US D648,792 S**

(45) **Date of Patent:** **\*\* Nov. 15, 2011**

(54) **PEN**

(75) Inventor: **Bin Li, Ningbo (CN)**

(73) Assignee: **Beifa Group Co., Ltd., Ningbo (CN)**

(\*\*) Term: **14 Years**

(21) Appl. No.: **29/382,831**

(22) Filed: **Jan. 7, 2011**

(30) **Foreign Application Priority Data**

Jul. 11, 2010 (CN) ..... 2010 3 0240111

(51) **LOC (9) Cl.** ..... **19-06**

(52) **U.S. Cl.** ..... **D19/51**

(58) **Field of Classification Search** ..... D19/35,

D19/36, 41-51, 54-58; 24/11 R, 11 F, 11 P;

401/52, 99, 100, 192, 195, 196; D14/411

See application file for complete search history.

(56) **References Cited**

**U.S. PATENT DOCUMENTS**

|              |         |              |        |
|--------------|---------|--------------|--------|
| D104,542 S   | 5/1937  | Pearce       |        |
| D304,601 S * | 11/1989 | Alskog       | D19/49 |
| D319,662 S * | 9/1991  | Henry        | D19/43 |
| D355,932 S   | 2/1995  | Beffa        |        |
| D360,432 S * | 7/1995  | Arsenault    | D19/42 |
| D368,738 S * | 4/1996  | Osada et al. | D19/51 |
| D394,875 S   | 6/1998  | Izushima     |        |
| D399,874 S   | 10/1998 | Gacia        |        |
| D421,052 S   | 2/2000  | Yazawa       |        |
| D423,577 S   | 4/2000  | Baudino      |        |
| D424,110 S * | 5/2000  | Hu           | D19/51 |
| D430,607 S   | 9/2000  | Matsuzaki    |        |
| D431,262 S   | 9/2000  | Izushima     |        |
| D431,599 S   | 10/2000 | Izushima     |        |
| D436,996 S   | 1/2001  | Izushima     |        |

|                |         |                  |         |
|----------------|---------|------------------|---------|
| 6,203,225 B1 * | 3/2001  | Baudino et al.   | 401/6   |
| D444,174 S     | 6/2001  | Izushima         |         |
| D444,815 S     | 7/2001  | Izushima         |         |
| D453,790 S *   | 2/2002  | Tsuchikura       | D19/36  |
| D454,368 S *   | 3/2002  | Pellissa Beneyto | D19/48  |
| D455,458 S     | 4/2002  | Izushima         |         |
| 6,375,373 B2 * | 4/2002  | Izushima         | 401/6   |
| D462,388 S *   | 9/2002  | Fiori et al.     | D19/51  |
| 6,491,467 B1 * | 12/2002 | Mitsuya          | 401/195 |
| D482,067 S     | 11/2003 | Yang             |         |
| D482,068 S *   | 11/2003 | Koch             | D19/51  |

(Continued)

**FOREIGN PATENT DOCUMENTS**

WO DM/047525 4/1999

**OTHER PUBLICATIONS**

Li, B., "Pen," U.S. Appl. No. 29/382,807, filed Jan. 7, 2011.

*Primary Examiner* — Elizabeth Albert

(74) *Attorney, Agent, or Firm* — Christensen O'Connor Johnson Kindness PLLC

(57) **CLAIM**

The ornamental design for a pen, as shown and described.

**DESCRIPTION**

FIG. 1 is an upper front left perspective view of a pen showing my new design;

FIG. 2 is a right side elevation view thereof, with the left side elevation view being a mirror image of the right side elevation view;

FIG. 3 is a front elevation view thereof;

FIG. 4 is a rear elevation view thereof;

FIG. 5 is an enlarged top plan view thereof; and,

FIG. 6 is an enlarged bottom plan view thereof.

**1 Claim, 3 Drawing Sheets**

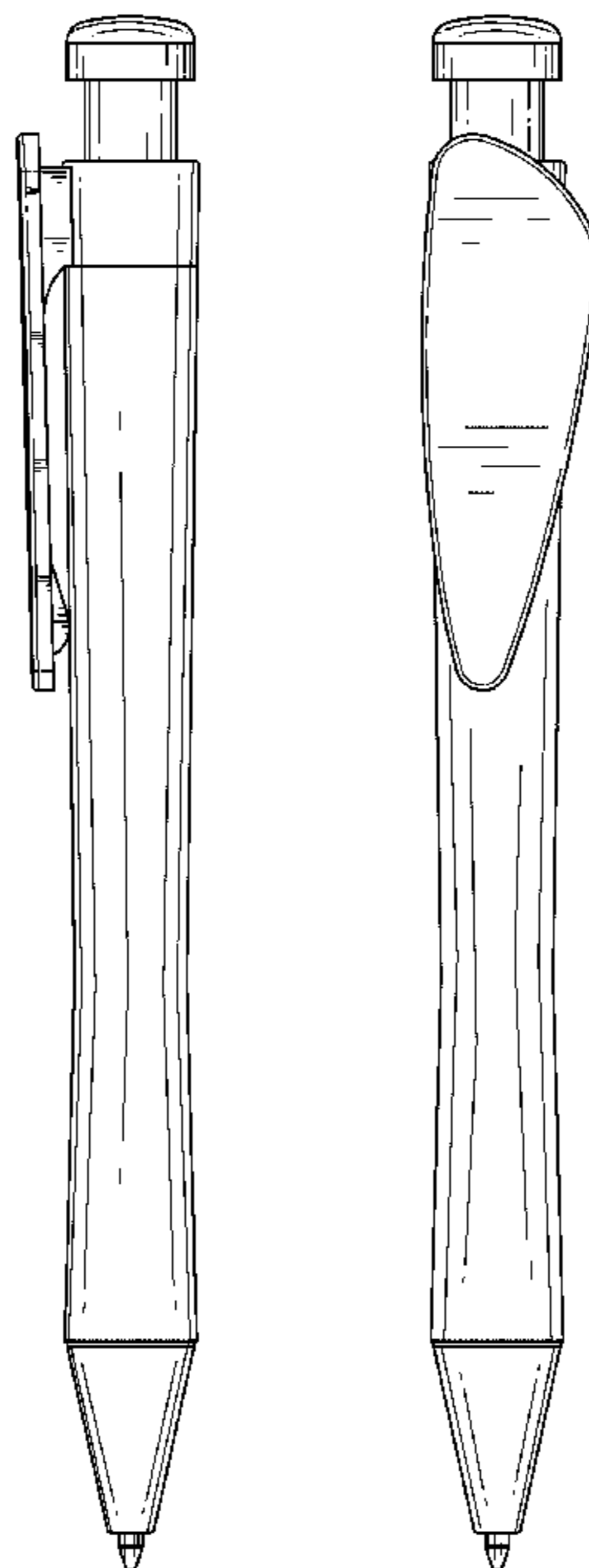

# US D648,792 S

Page 2

---

## U.S. PATENT DOCUMENTS

|              |         |                  |       |              |        |         |       |        |
|--------------|---------|------------------|-------|--------------|--------|---------|-------|--------|
| D489,090 S   | 4/2004  | Buechler         |       | D575,817 S * | 8/2008 | Loesel  | ..... | D19/48 |
| D501,031 S   | 1/2005  | Lecce            |       | D577,067 S   | 9/2008 | Koch    |       |        |
| D506,781 S   | 6/2005  | Koch             |       | D577,383 S * | 9/2008 | Loesel  | ..... | D19/48 |
| D509,853 S * | 9/2005  | Anand            | ..... | D589,559 S   | 3/2009 | Slemp   |       |        |
| D523,081 S * | 6/2006  | Pellissa Beneyto | ..... | D596,228 S * | 7/2009 | Koch    | ..... | D19/41 |
| D537,878 S * | 3/2007  | Anand            | ..... | D611,538 S   | 3/2010 | Zhou    |       |        |
| D554,702 S * | 11/2007 | Paslawski        | ..... | D613,337 S * | 4/2010 | Pearson | ..... | D19/50 |
| D566,180 S   | 4/2008  | Mori             |       | D615,590 S   | 5/2010 | Li      |       |        |

\* cited by examiner

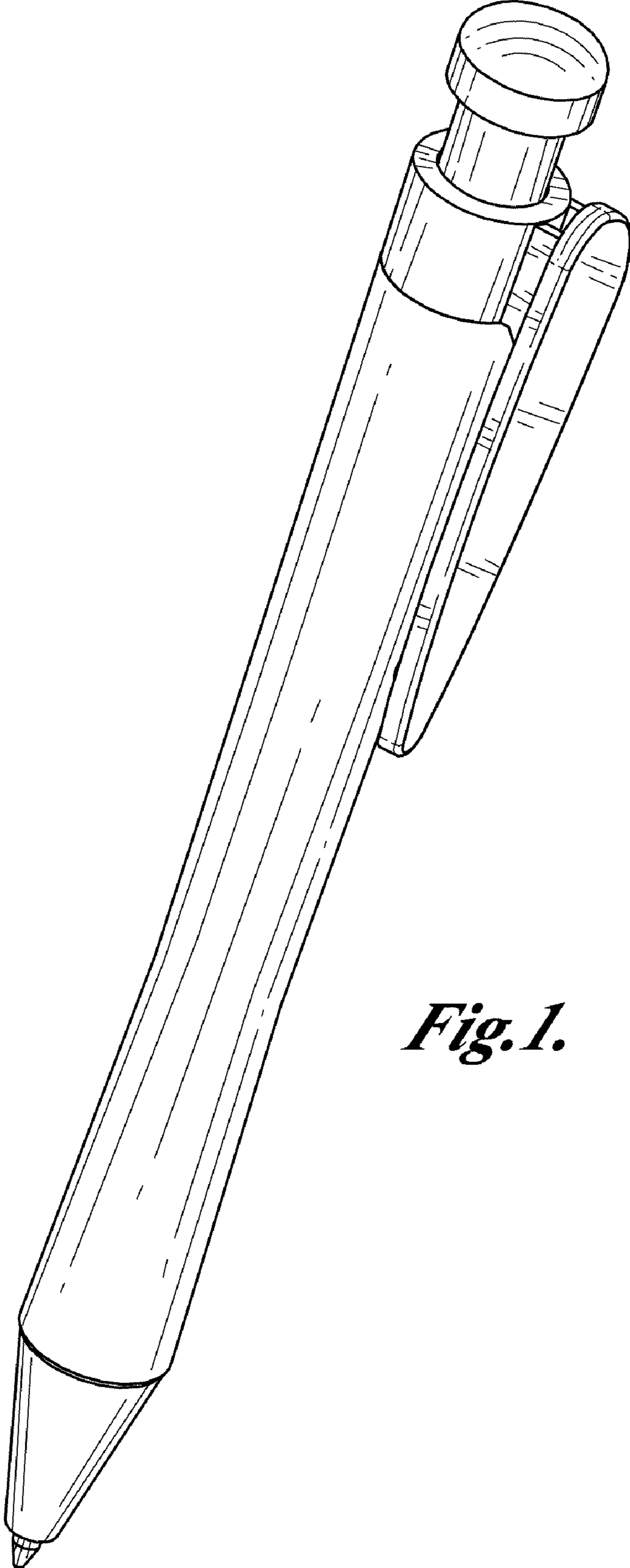

*Fig. 1.*

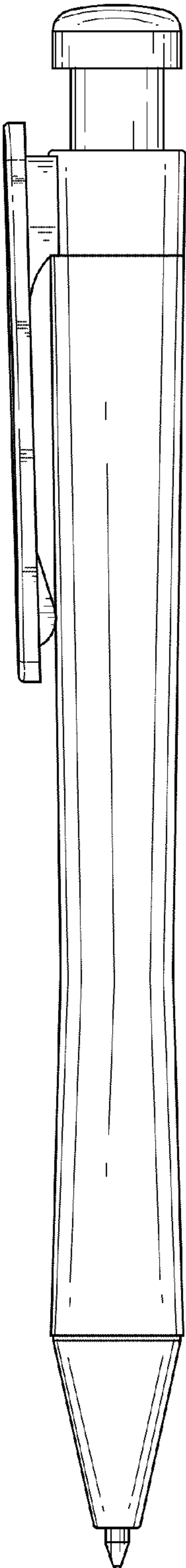

*Fig. 2.*

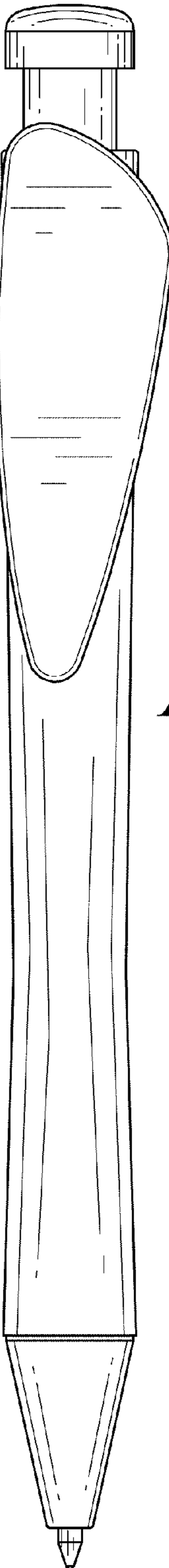

*Fig. 3.*

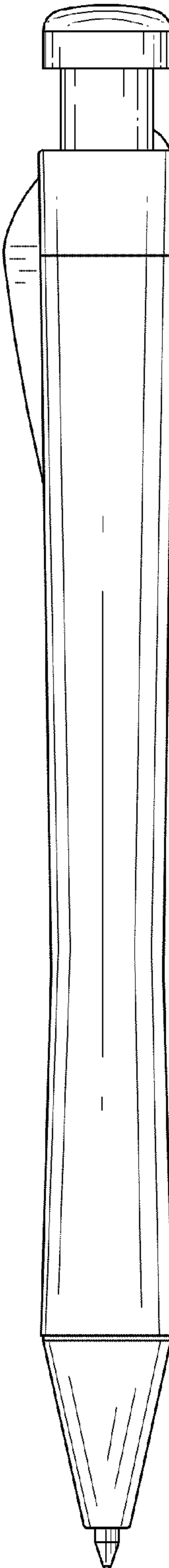

*Fig. 4.*

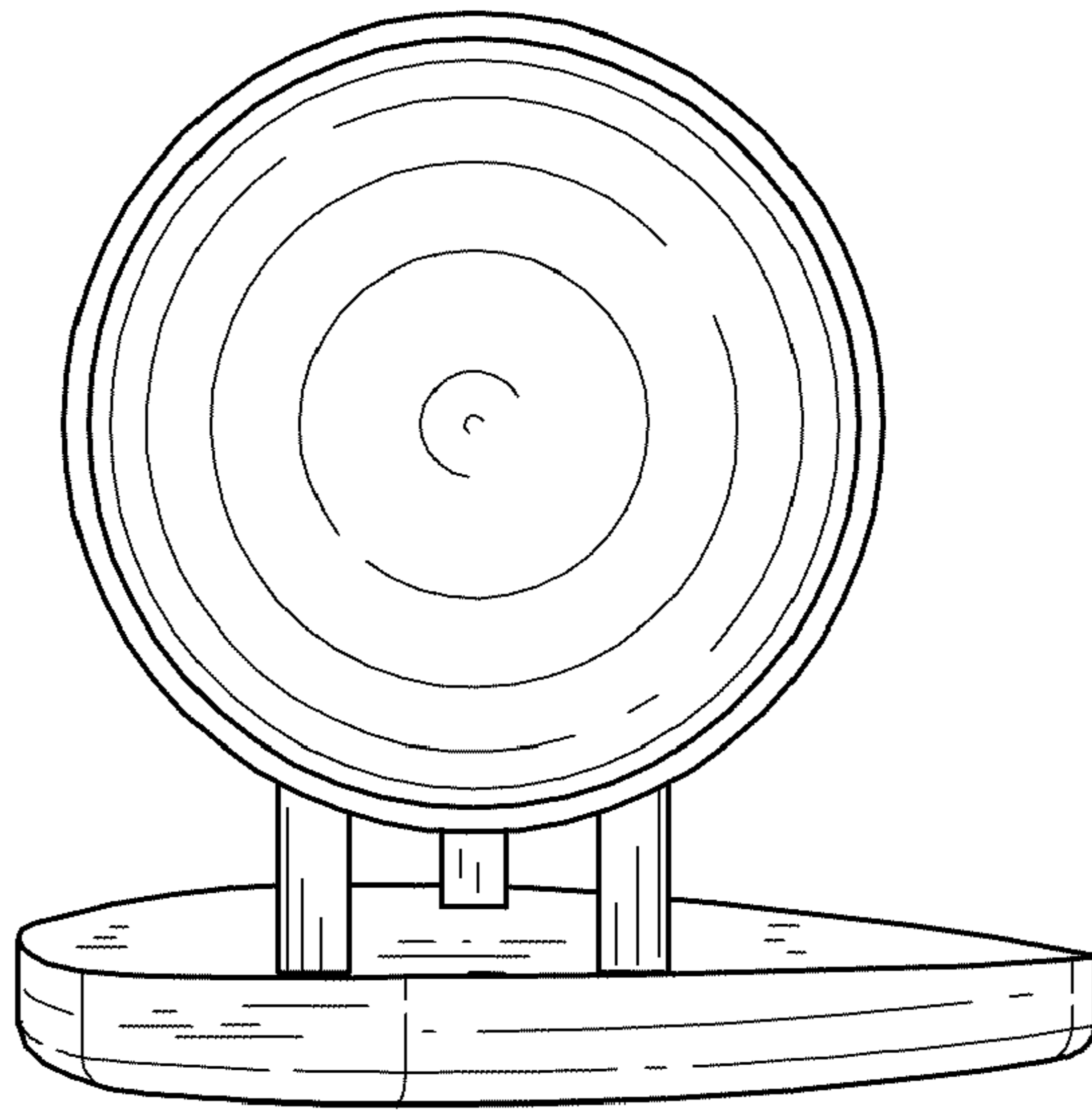

*Fig. 5.*

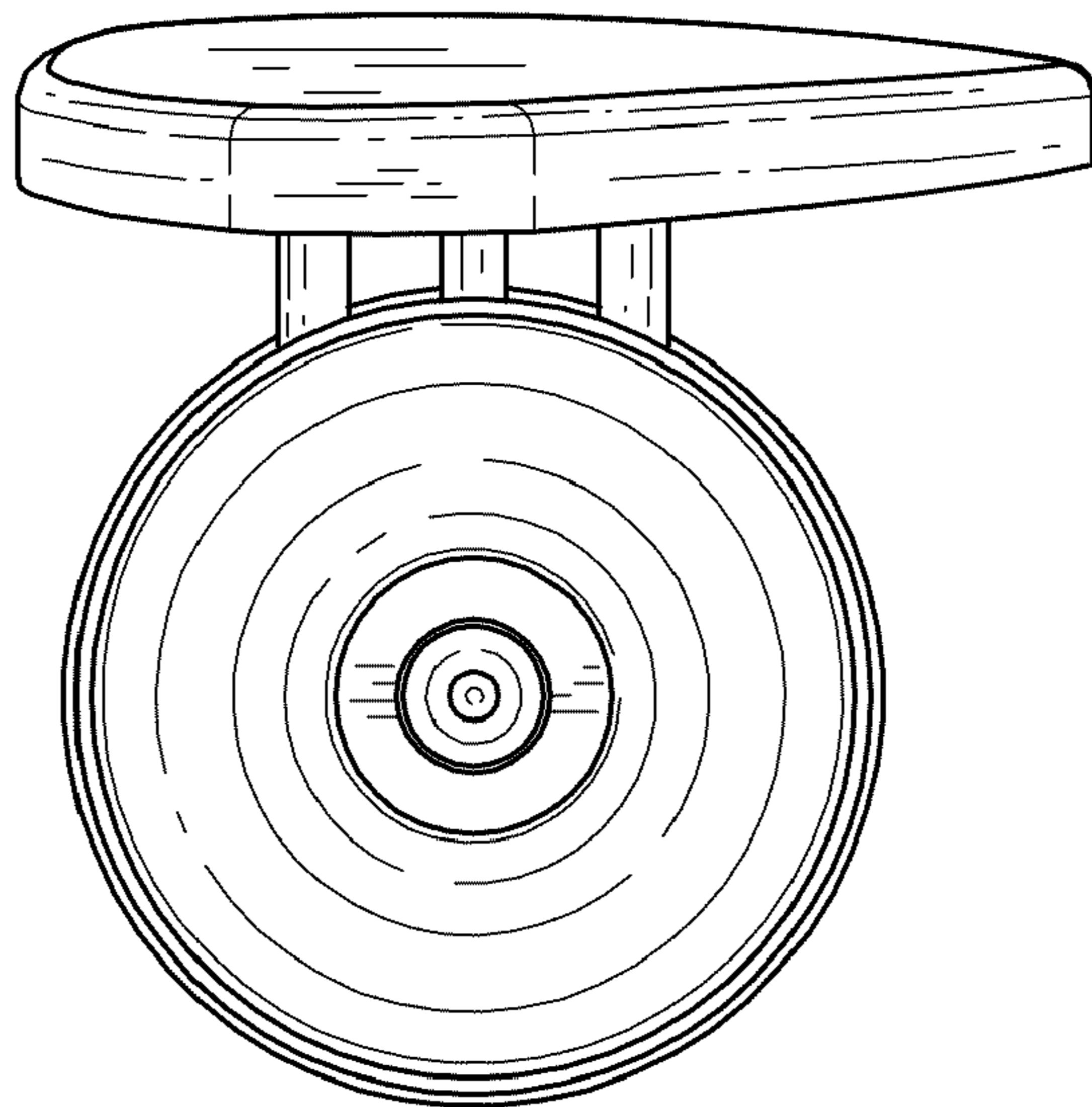

*Fig. 6.*