



US00D648580S

(12) **United States Design Patent**
Gasser

(10) **Patent No.:** **US D648,580 S**

(45) **Date of Patent:** **** Nov. 15, 2011**

(54) **FULL BACKREST SEAT**

(75) **Inventor:** **Mark E. Gasser**, Hubbard, OH (US)

(73) **Assignee:** **Gasser Chair Company, Inc.**,
Youngstown, OH (US)

(**) **Term:** **14 Years**

(21) **Appl. No.:** **29/361,880**

(22) **Filed:** **May 17, 2010**

(51) **LOC (9) Cl.** **06-01**

(52) **U.S. Cl.** **D6/500**

(58) **Field of Classification Search** D6/334,
D6/335, 337, 349, 353, 380, 381, 500-502,
D6/374; 297/14, 43, 44, 118, 140, 245, 300.1,
297/311, 353, 354.1, 445.1, 446.1, 446.2,
297/447.4, 465, 900, DIG. 2, DIG. 7; 5/12.1,
5/12.2

See application file for complete search history.

(56) **References Cited**

U.S. PATENT DOCUMENTS

3,041,110	A *	6/1962	King et al.	297/451.1
3,159,428	A *	12/1964	Schier	297/452.65
4,768,833	A *	9/1988	Virtue	297/440.2
D297,890	S *	10/1988	Hockenberry et al.	D6/367
D382,150	S *	8/1997	Balderi et al.	D6/502
D386,910	S *	12/1997	Saiger	D6/334
D393,956	S *	5/1998	Kane	D6/374
D401,769	S *	12/1998	Kaiser	D6/334
D432,321	S *	10/2000	Buehler	D6/334
D437,124	S *	2/2001	Kemnitzner	D6/334
D469,263	S *	1/2003	Clark et al.	D6/334
D498,366	S *	11/2004	Barile et al.	D6/369
D521,264	S *	5/2006	Ware et al.	D6/374

D546,569	S *	7/2007	Jones	D6/334
D555,381	S *	11/2007	Swanson	D6/380
D558,480	S *	1/2008	Olano Jauregui	D6/379
D573,804	S *	7/2008	Bartlmae	D6/374
D589,275	S *	3/2009	Kubryk	D6/374
D591,968	S *	5/2009	Pinaffo et al.	D6/380
D591,969	S *	5/2009	Overthun et al.	D6/380
D593,336	S *	6/2009	Ciani et al.	D6/374
D610,844	S *	3/2010	Muller	D6/502
D617,570	S *	6/2010	Kubryk	D6/380

* cited by examiner

Primary Examiner — Sandra Snapp

(74) *Attorney, Agent, or Firm* — Lerner, David, Littenberg,
Krumholz & Mentlik, LLP

(57) **CLAIM**

The ornamental design for a full backrest seat, as shown and described.

DESCRIPTION

FIG. 1 is a front perspective view of a first embodiment full backrest seat, in accordance with the present invention; FIG. 2 is a front elevation view of the full backrest seat shown in FIG. 1; FIG. 3 is a back elevation view of the full backrest seat shown in FIG. 1; FIG. 4 is a left side elevation view of the full backrest seat shown in FIG. 1; FIG. 5 is a right side elevation view of the full backrest seat shown in FIG. 1; and, FIG. 6 is a top plan view of the full backrest seat as shown in FIG. 1.

The broken lines shown in the drawings are for illustrative purposes and form no part of the claimed design.

1 Claim, 6 Drawing Sheets

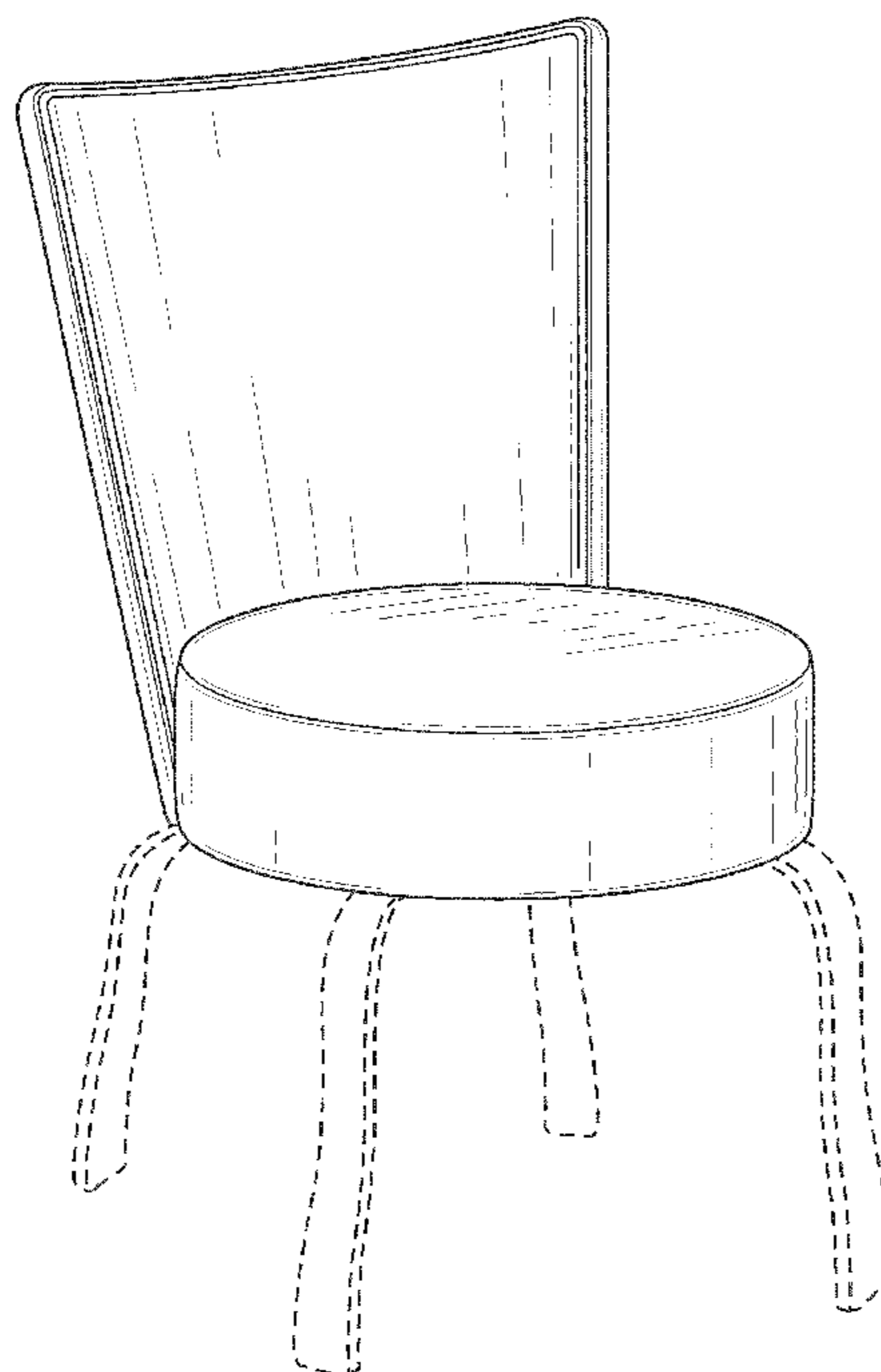

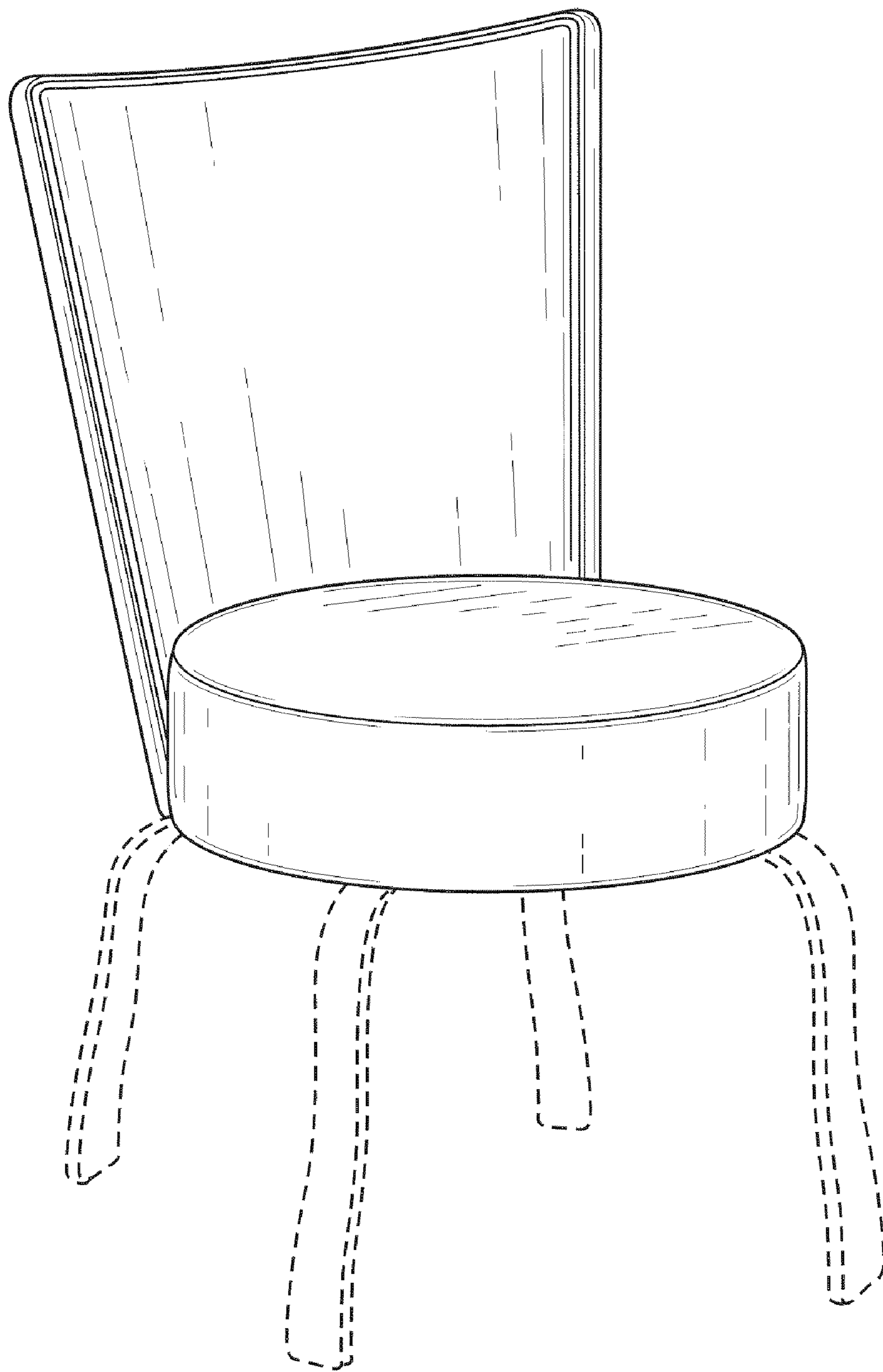

FIG. 1

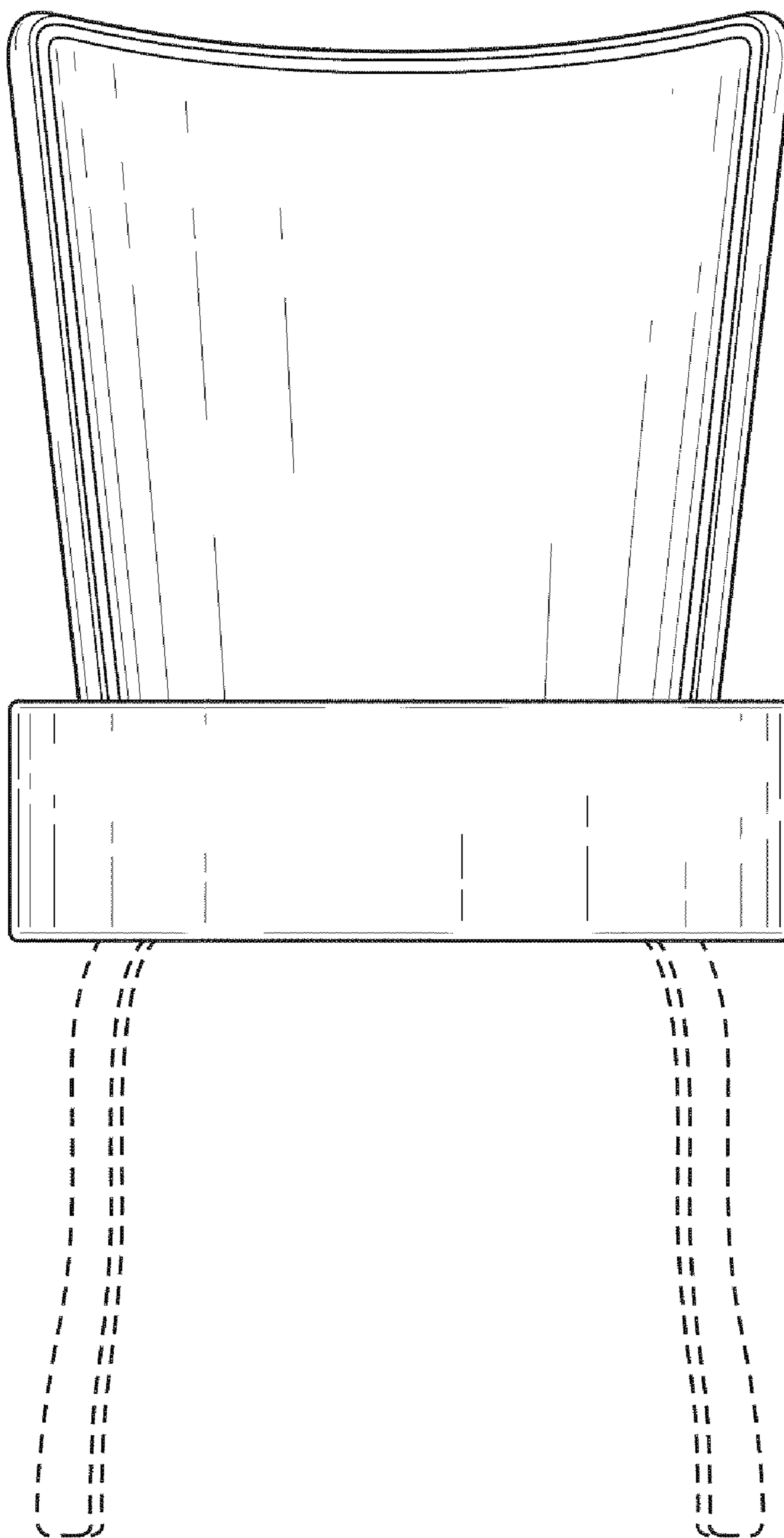

FIG. 2

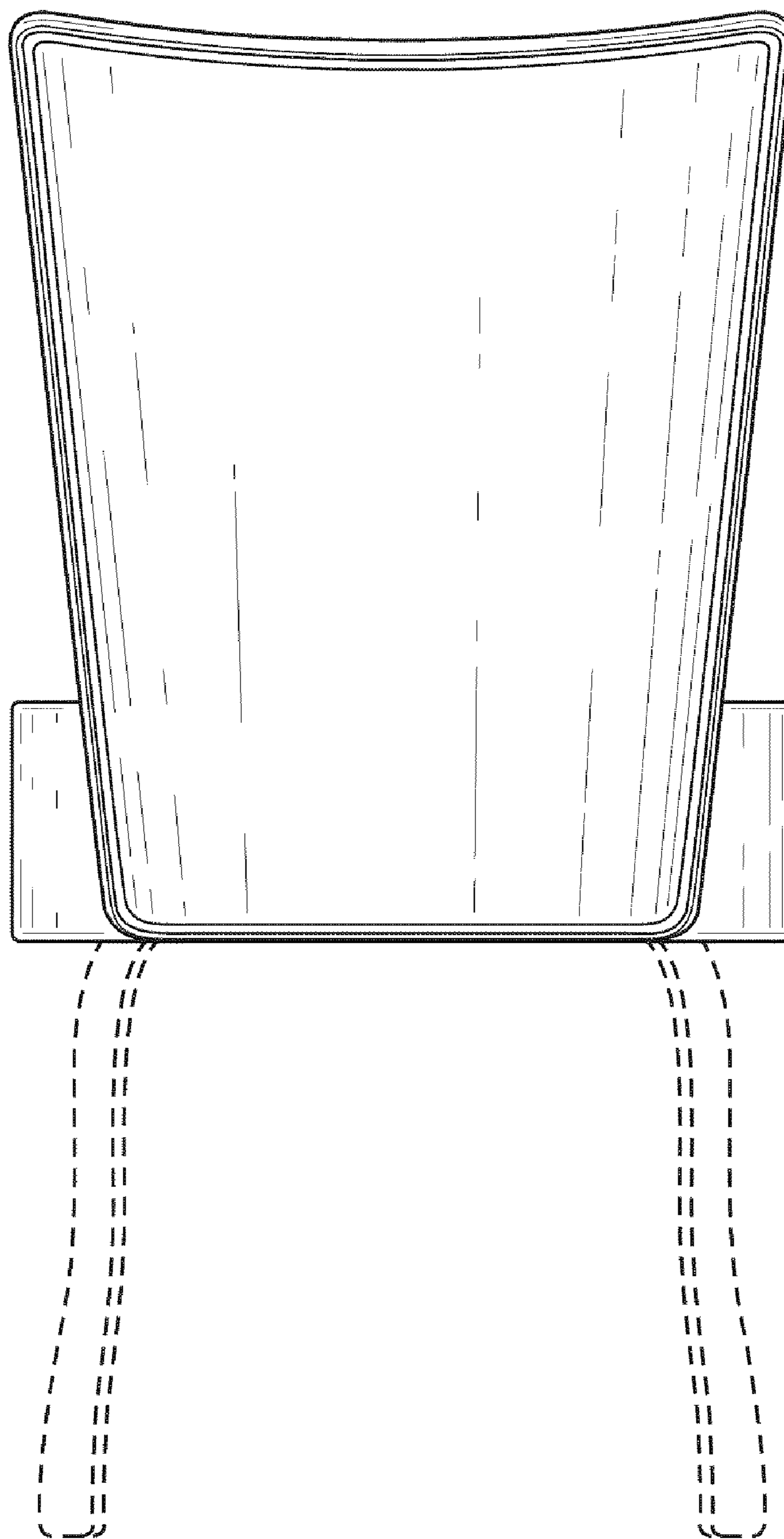

FIG. 3

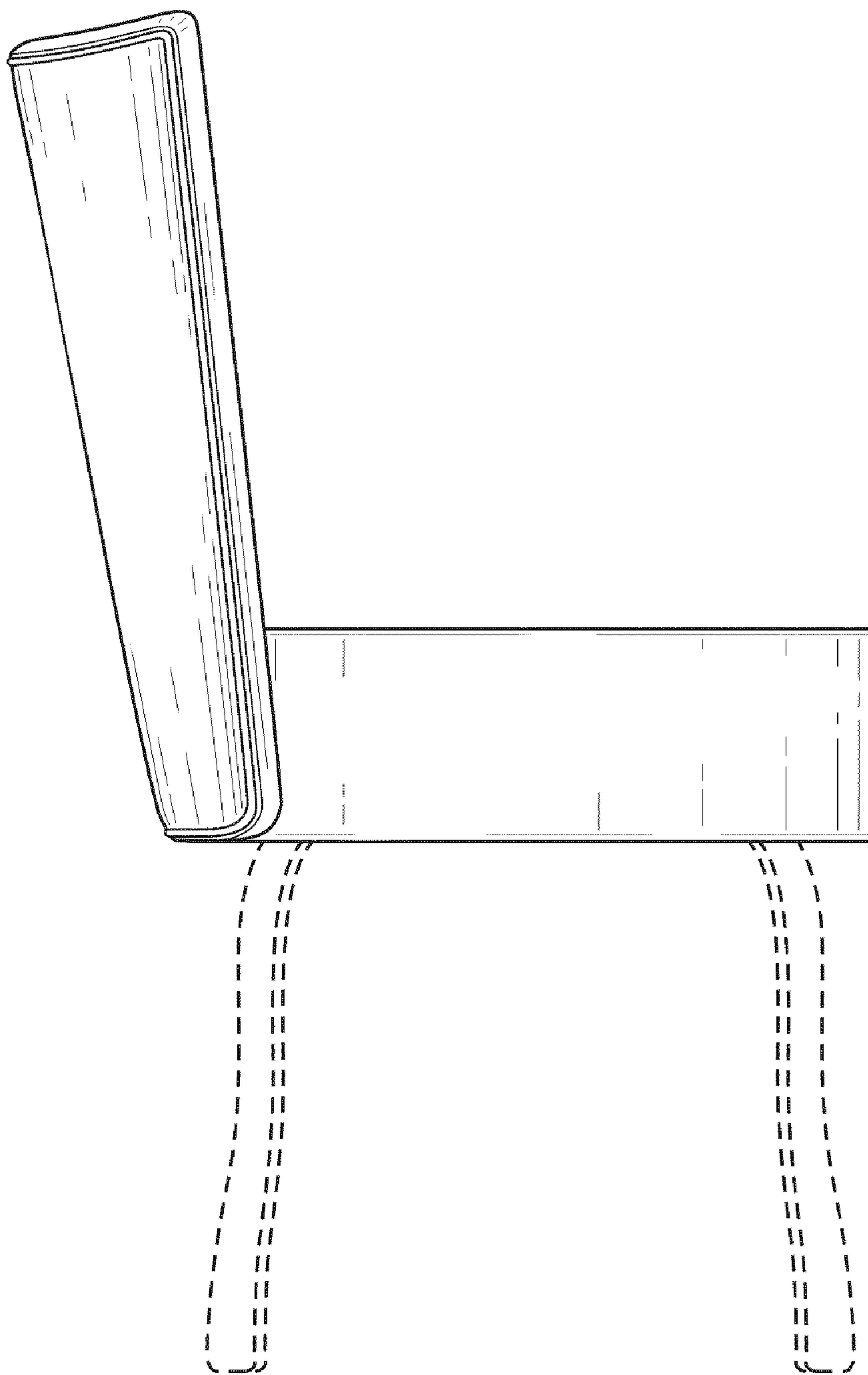

FIG. 4

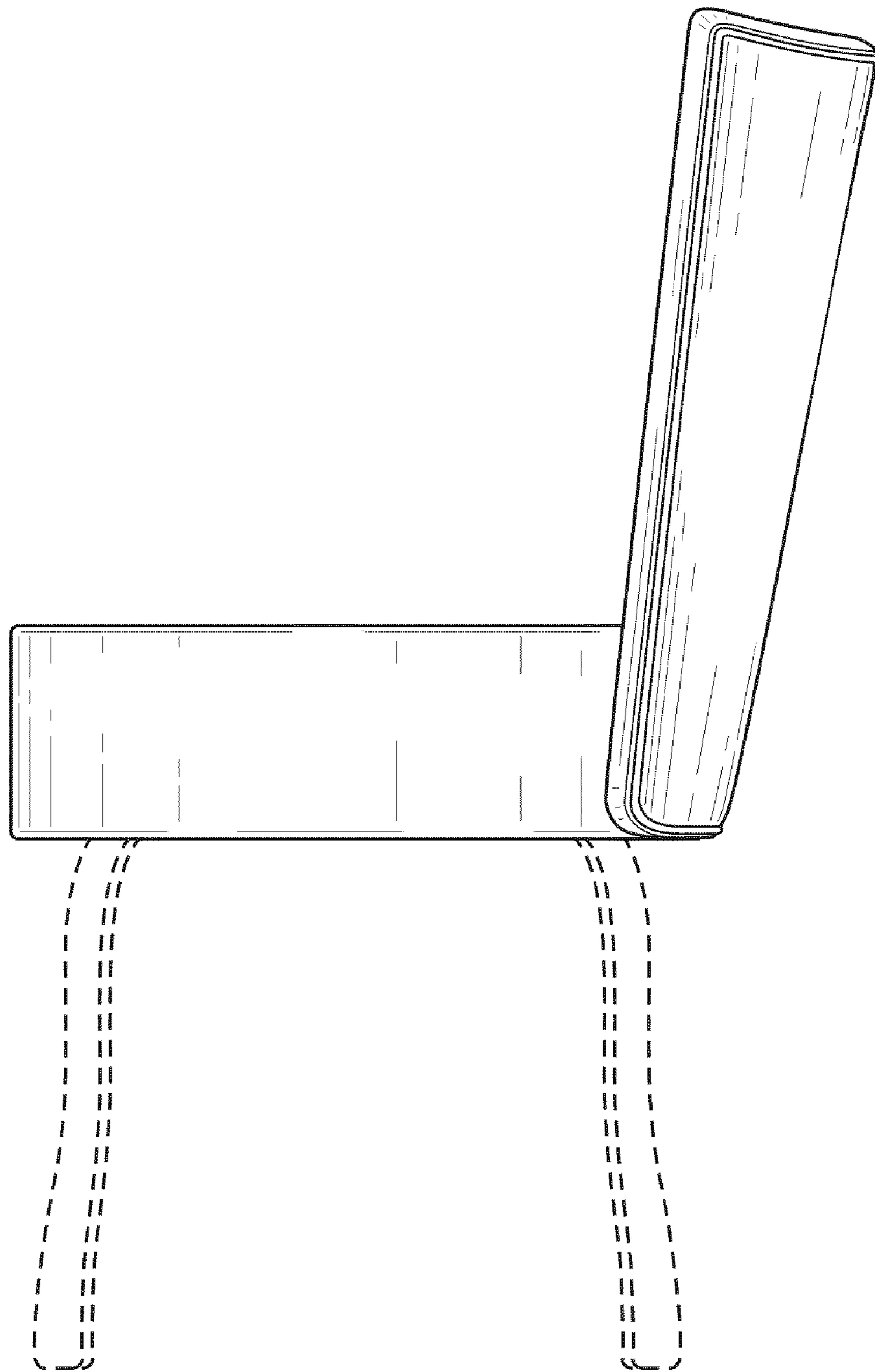

FIG. 5

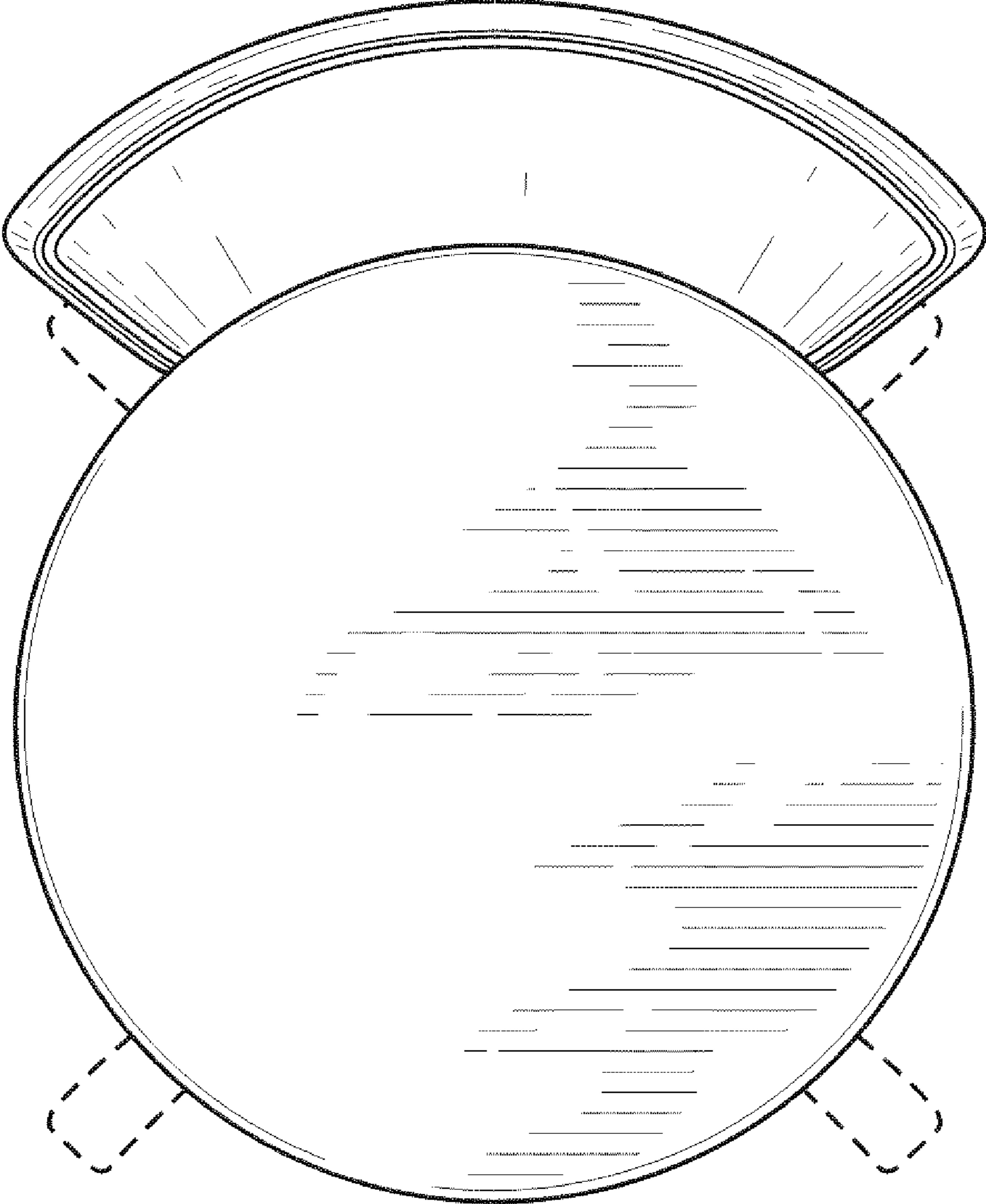

FIG. 6