



US00D647880S

(12) **United States Design Patent**  
**Huber et al.**

(10) **Patent No.:** **US D647,880 S**

(45) **Date of Patent:** **\*\* Nov. 1, 2011**

(54) **AUDIO MIXER**

(75) Inventors: **Robert Huber**, Geroldswil (CH); **Rene Wussler**, Watt (CH); **Andy Brown**, Middlesex (GB)

(73) Assignee: **Harman International Industries, Incorporated**, Northridge, CA (US)

(\*\*) Term: **14 Years**

(21) Appl. No.: **29/353,385**

(22) Filed: **Jan. 7, 2010**

(51) **LOC (9) Cl.** ..... **14-01**

(52) **U.S. Cl.** ..... **D14/217**

(58) **Field of Classification Search** ..... D14/162,  
D14/167-169, 175, 188, 196-198, 217, 257,  
D14/258, 496; D13/163, 164; 84/625, 660,  
84/697; 455/350

See application file for complete search history.

(56) **References Cited**

**U.S. PATENT DOCUMENTS**

4,879,751 A	11/1989	Franks et al.	
D325,383 S *	4/1992	Ito et al.	D14/217
D344,726 S	3/1994	Amiya	
D357,255 S *	4/1995	Ito et al.	D14/217
D375,747 S	11/1996	East	
D380,760 S	7/1997	Mackie et al.	
D398,289 S	9/1998	Burke	
D401,242 S	11/1998	Mackie et al.	
D408,820 S *	4/1999	Ito et al.	D14/217
D410,007 S	5/1999	Mackie et al.	
D411,997 S	7/1999	Ito et al.	
D420,332 S	2/2000	Lee et al.	
D424,056 S *	5/2000	Ito et al.	D14/162
D426,231 S *	6/2000	Mackie	D14/217
D434,407 S *	11/2000	Mackie	D14/217
D435,250 S *	12/2000	Mackie et al.	D14/217
D442,944 S	5/2001	Page et al.	

D453,327 S *	2/2002	Takita et al.	D14/217
D455,731 S *	4/2002	Mackie et al.	D14/217
6,438,241 B1	8/2002	Silfvast et al.	
D470,834 S	2/2003	Saito	
6,728,382 B1	4/2004	Silfvast	
D489,709 S	5/2004	Amiya	
D490,800 S *	6/2004	Kitazawa	D14/217
D491,554 S *	6/2004	Amiya	D14/217
D511,767 S *	11/2005	Ishizaki et al.	D14/217
D554,623 S	11/2007	Wussler et al.	
D561,735 S *	2/2008	Nagura et al.	D14/168
D568,873 S	5/2008	Wussler et al.	
D569,370 S	5/2008	Wussler et al.	
D573,587 S *	7/2008	Amiya	D14/217
D588,580 S	3/2009	Chisholm et al.	
D609,218 S *	2/2010	Ito	D14/217
D609,219 S *	2/2010	Ito	D14/217
D630,617 S *	1/2011	Ayres et al.	D14/217

\* cited by examiner

*Primary Examiner* — Prabhakar Deshmukh

*Assistant Examiner* — Keli L Hill

(74) *Attorney, Agent, or Firm* — Plumsea Law Group, LLC

(57) **CLAIM**

The ornamental design for an audio mixer, as shown and described.

**DESCRIPTION**

FIG. 1 is a front, top and side perspective view of a audio mixer, embodying our new design;  
FIG. 2 is a rear, top and side perspective view thereof;  
FIG. 3 is a front elevational view thereof;  
FIG. 4 is a side elevational view of one side thereof;  
FIG. 5 is a bottom plan view thereof; and,  
FIG. 6 is a rear elevational view thereof.  
The broken lines shown are included for the purpose of illustrating the unclaimed portions of the article and form no part of the claim.

**1 Claim, 6 Drawing Sheets**

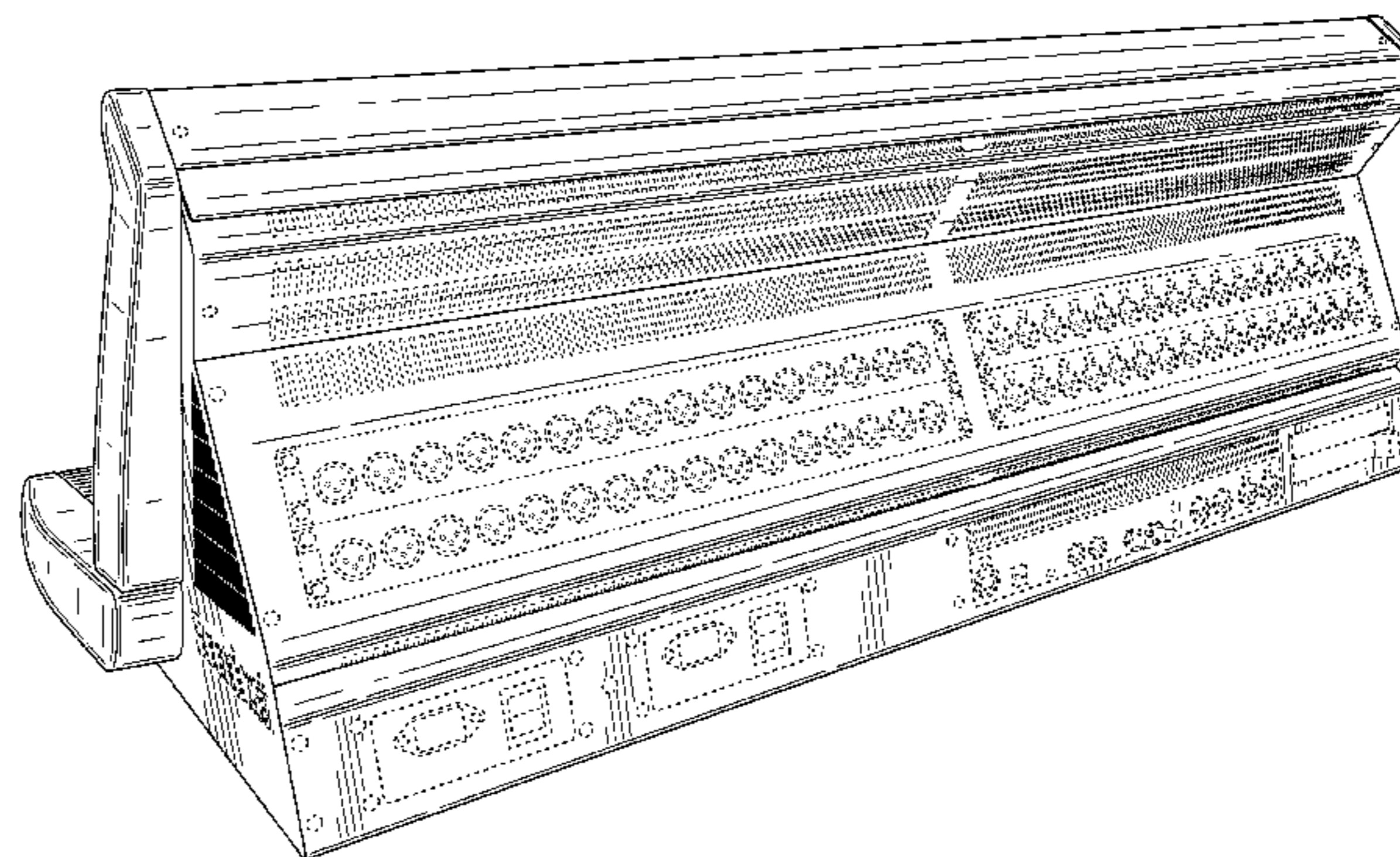
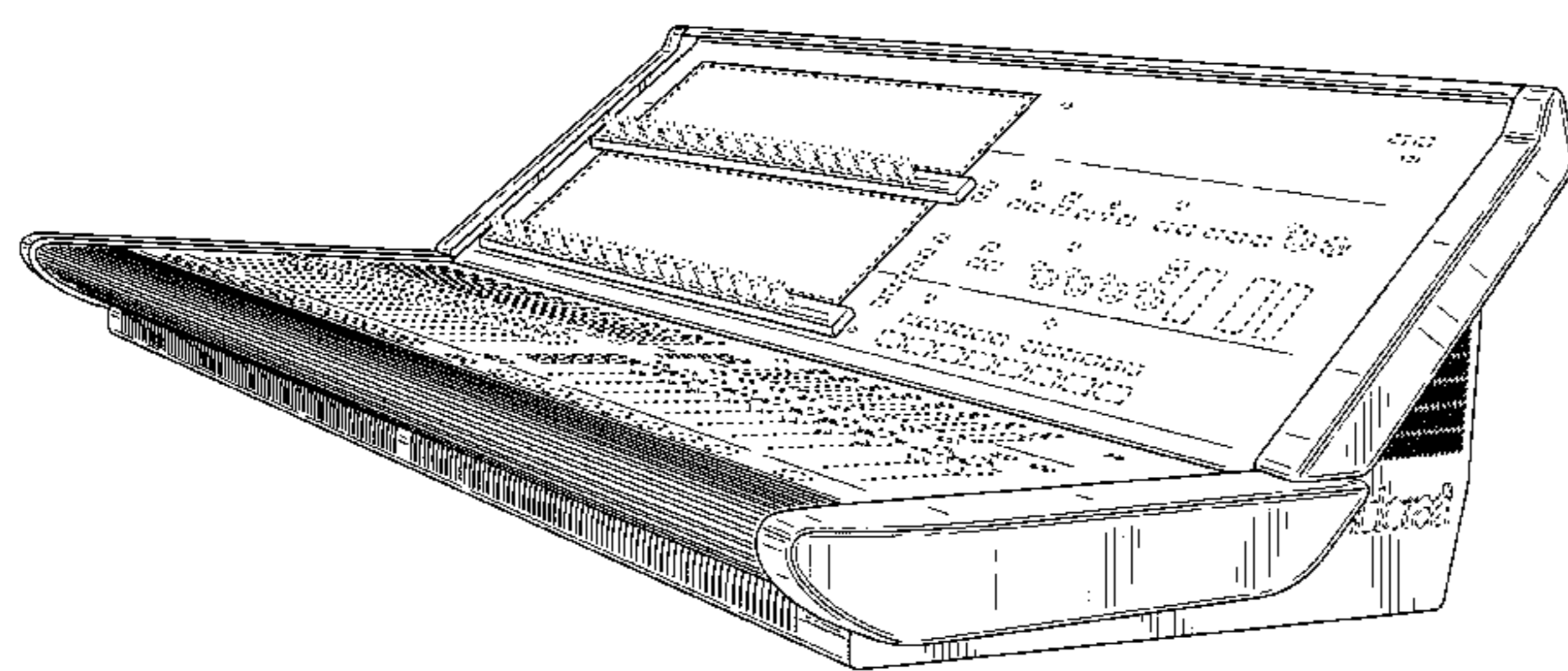

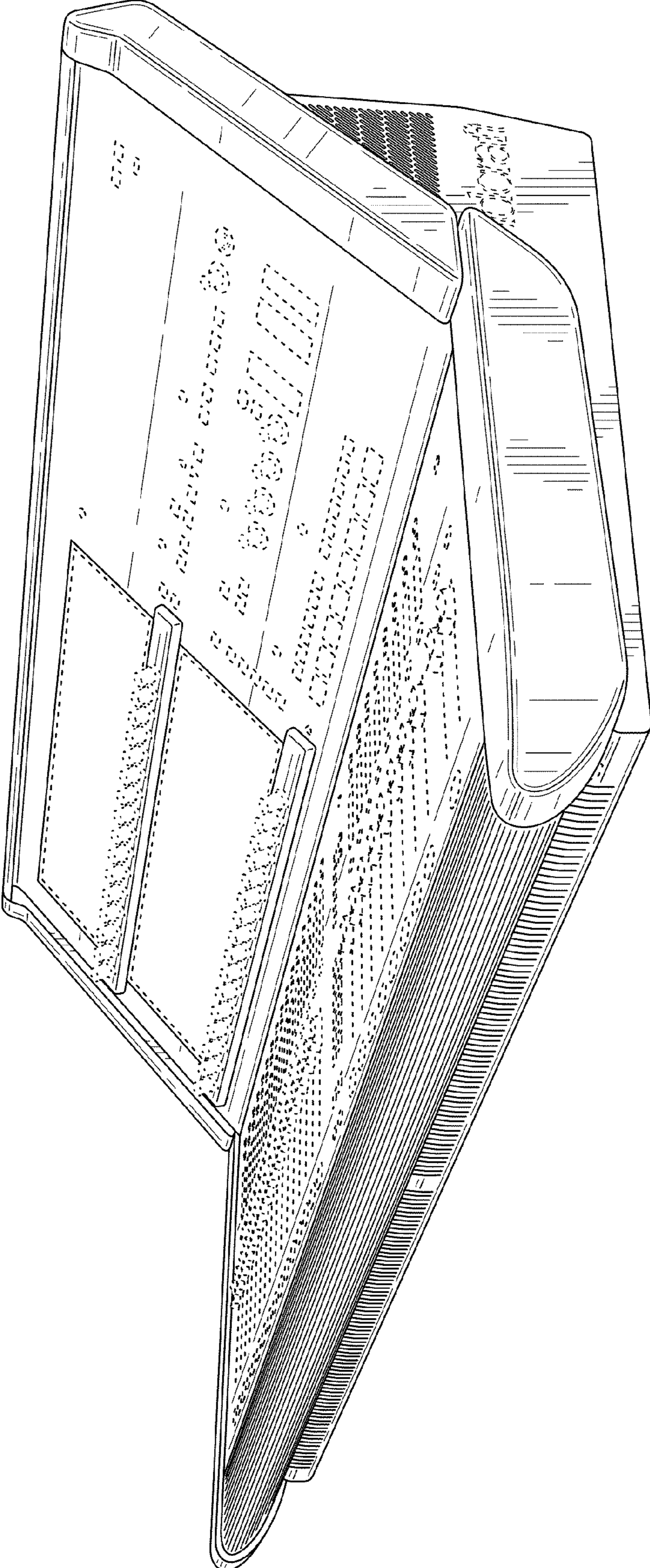

FIG. 1



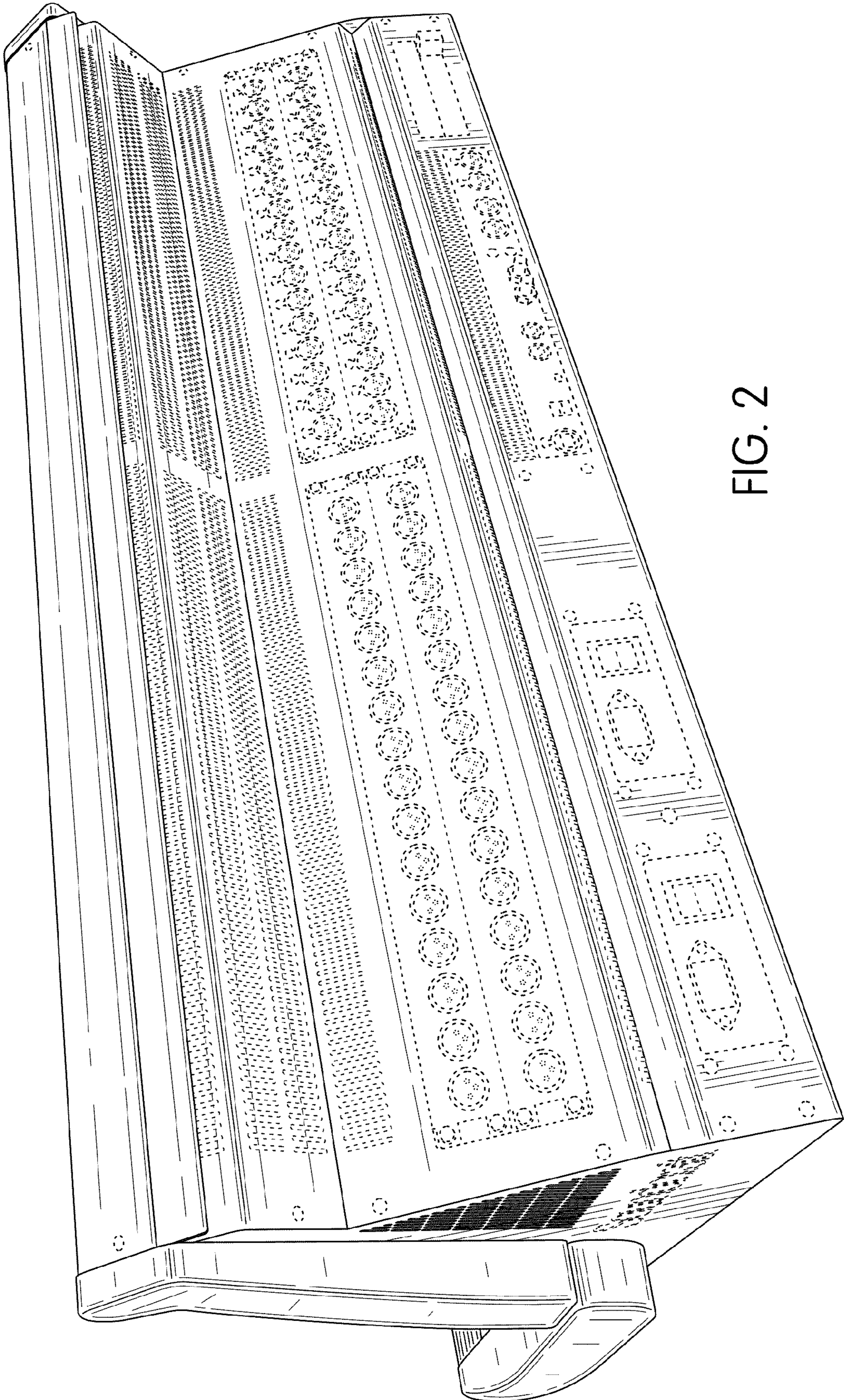

FIG. 2



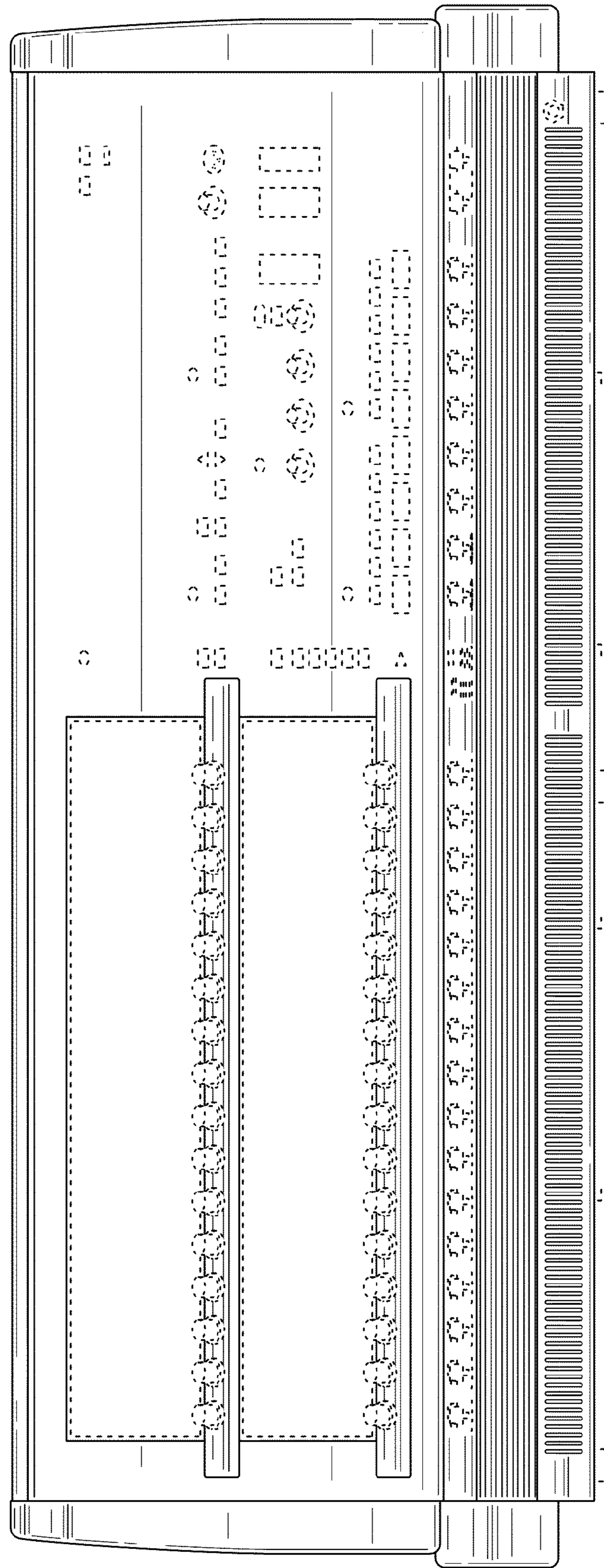

FIG. 3

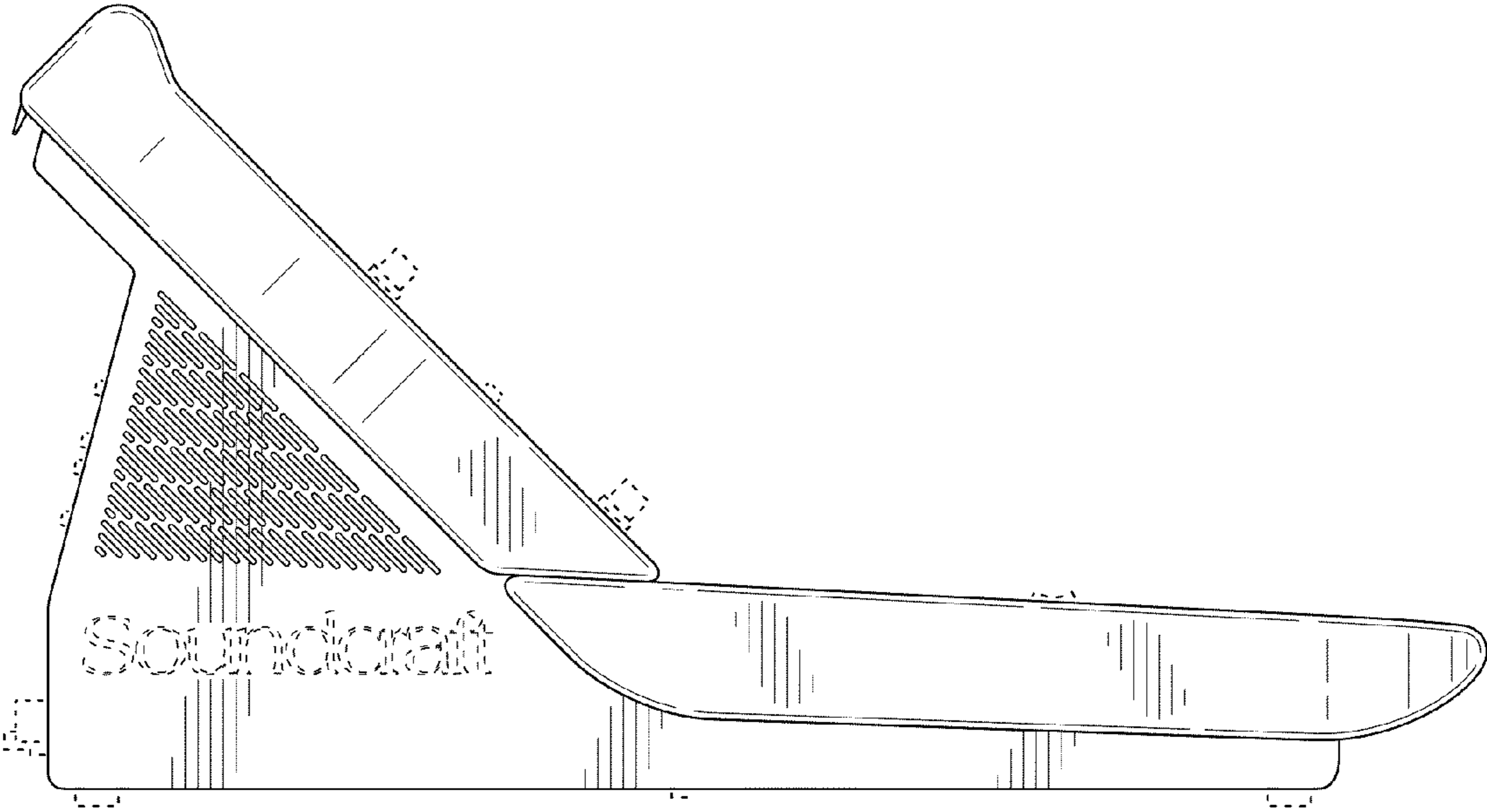

FIG. 4

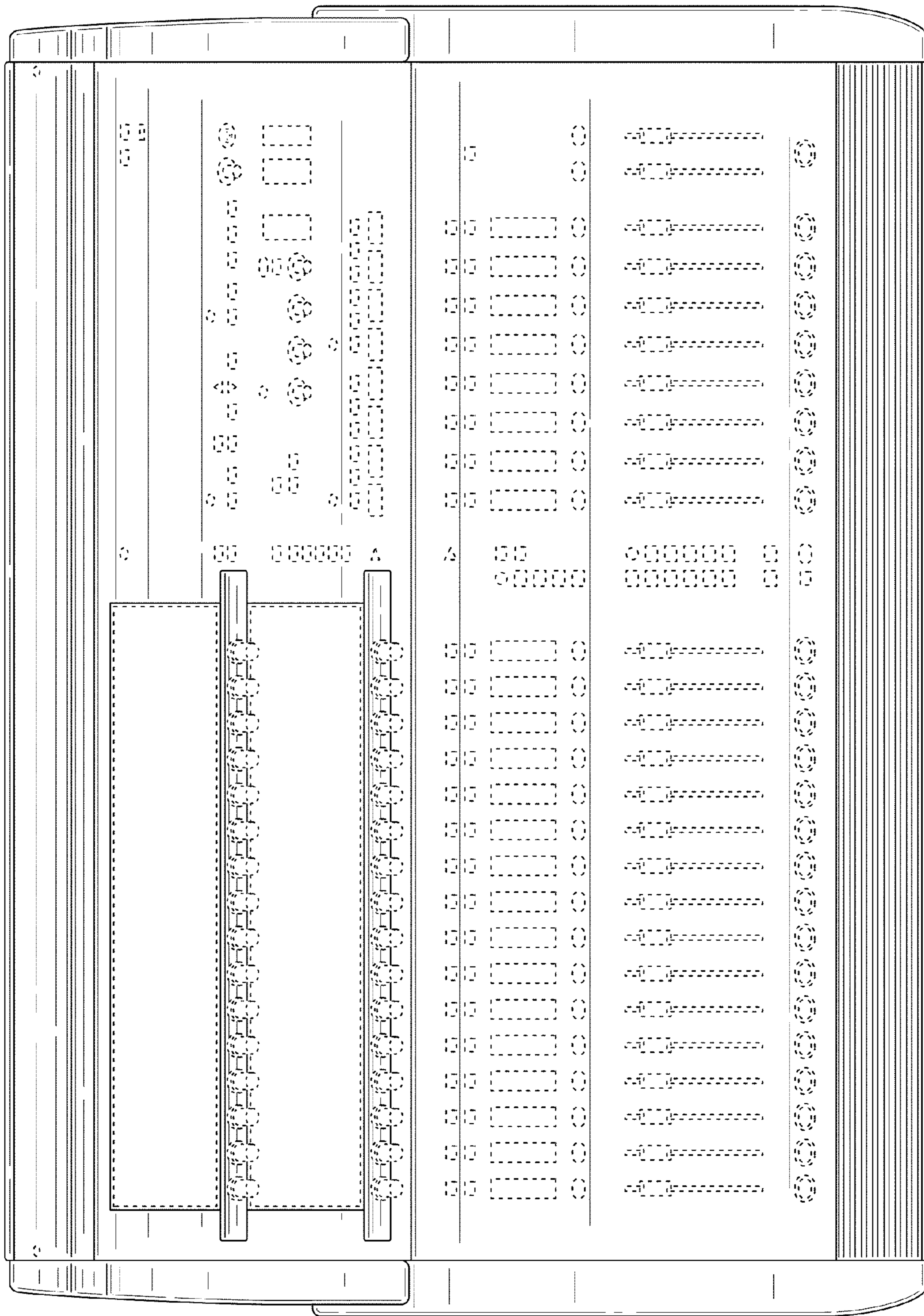

FIG. 5



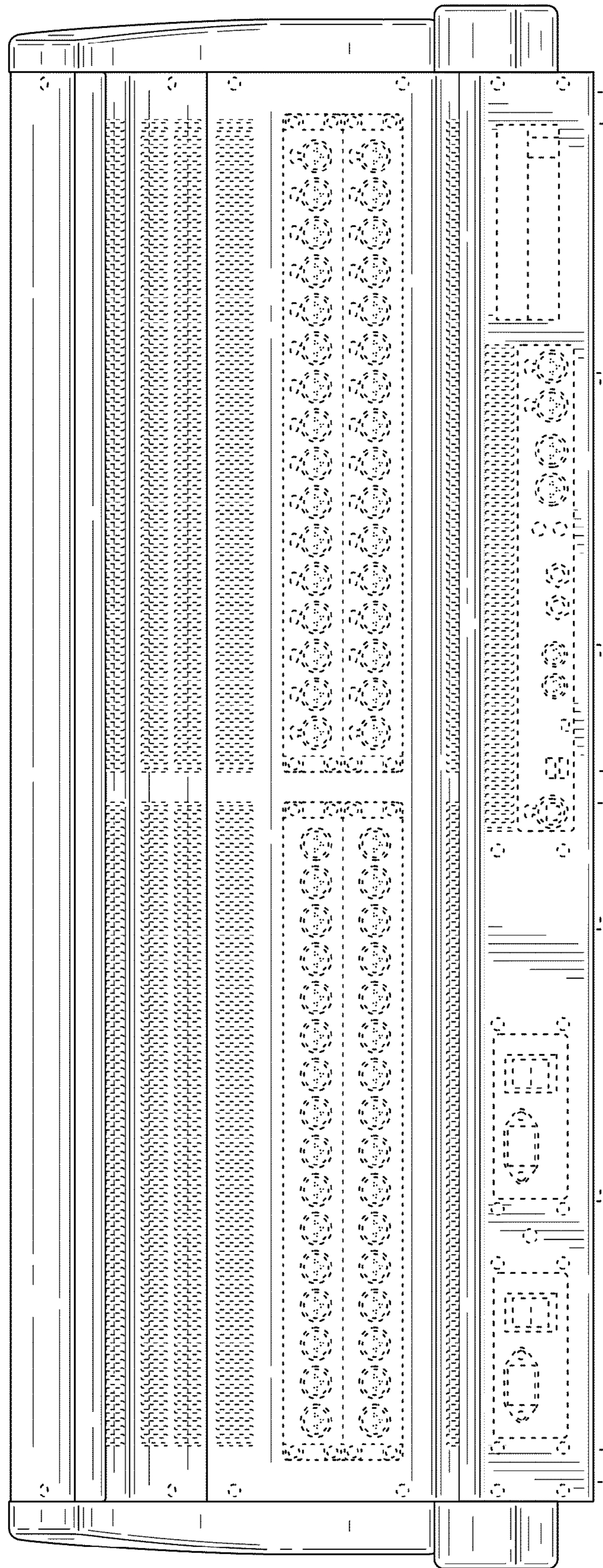

FIG. 6