



US00D647431S

(12) **United States Design Patent**  
**Schell et al.**

(10) **Patent No.:** **US D647,431 S**

(45) **Date of Patent:** **\*\* Oct. 25, 2011**

(54) **VEHICLE EXTERIOR**

(75) Inventors: **Damon Schell**, San Pedro, CA (US);  
**Chihiro Ikemizu**, Redondo Beach, CA  
(US); **Henry Anton Schmid, IV**, Palm  
Desert, CA (US); **Alicia Akino Higa**,  
Hawthorne, CA (US)

(73) Assignee: **Honda Motor Co., Ltd.**, Tokyo (JP)

(\*\*) Term: **14 Years**

(21) Appl. No.: **29/375,341**

(22) Filed: **Sep. 21, 2010**

(51) **LOC (9) Cl.** ..... **12-08**

(52) **U.S. Cl.** ..... **D12/92**

(58) **Field of Classification Search** ..... D12/86,  
D12/90-92, 88; D21/424, 433, 434; 296/181.1,  
296/181.5

See application file for complete search history.

(56) **References Cited**

**U.S. PATENT DOCUMENTS**

D586,263 S \* 2/2009 Osborne et al. .... D12/92

D599,706 S \* 9/2009 Tanaka et al. .... D12/92  
D619,048 S \* 7/2010 Christensen et al. .... D12/92  
D619,500 S \* 7/2010 Hsu et al. .... D12/91

\* cited by examiner

*Primary Examiner* — Melody N Brown

(74) *Attorney, Agent, or Firm* — Plumsea Law Group, LLC;  
Mark E. Duell

(57) **CLAIM**

The ornamental design for a vehicle exterior, as shown and  
described.

**DESCRIPTION**

FIG. 1 is a perspective view of a vehicle exterior showing our  
new design;

FIG. 2 is a rear perspective view thereof;

FIG. 3 is a front elevational view thereof;

FIG. 4 is a rear elevational view thereof; and,

FIG. 5 is an enlarged partial front perspective view thereof.

The broken lines shown throughout the drawing are for illus-  
trative purposes only and form no part of the claimed design.

**1 Claim, 4 Drawing Sheets**

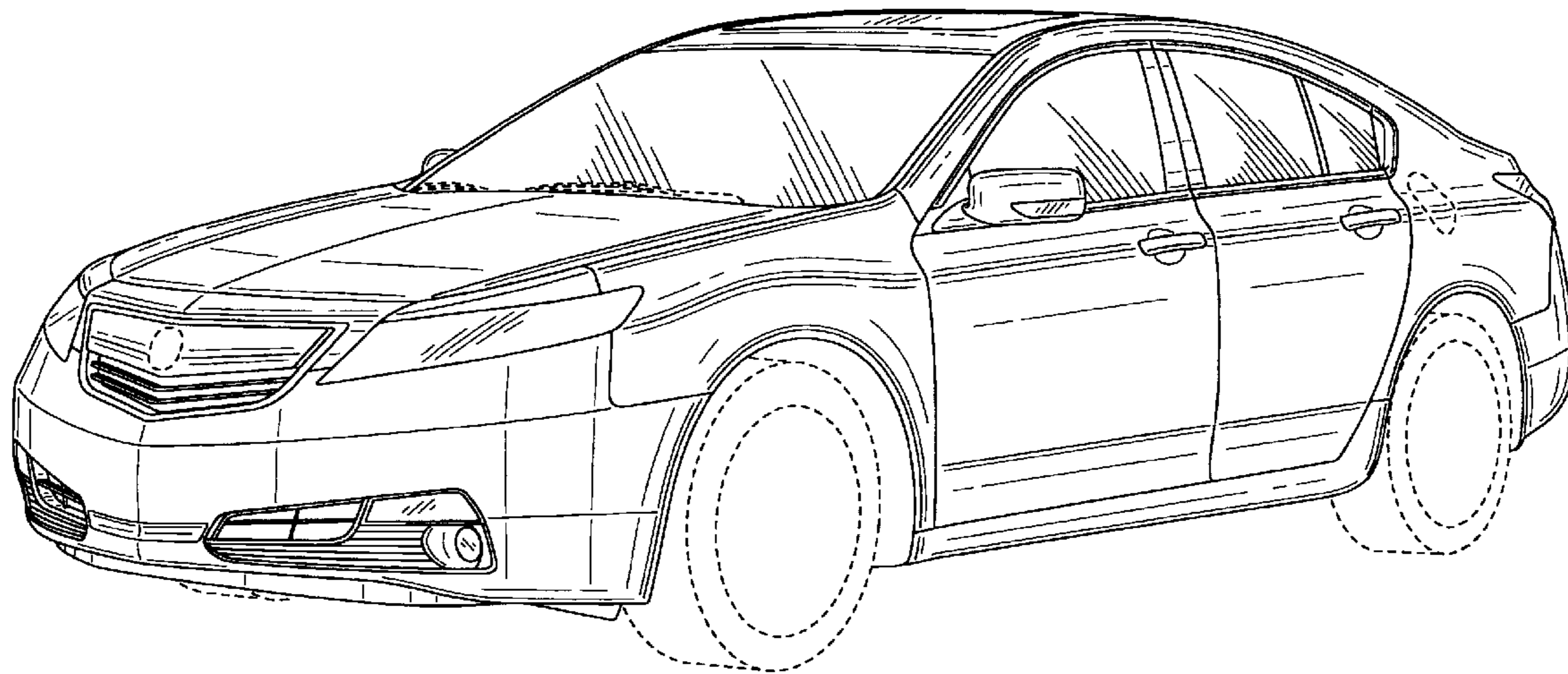

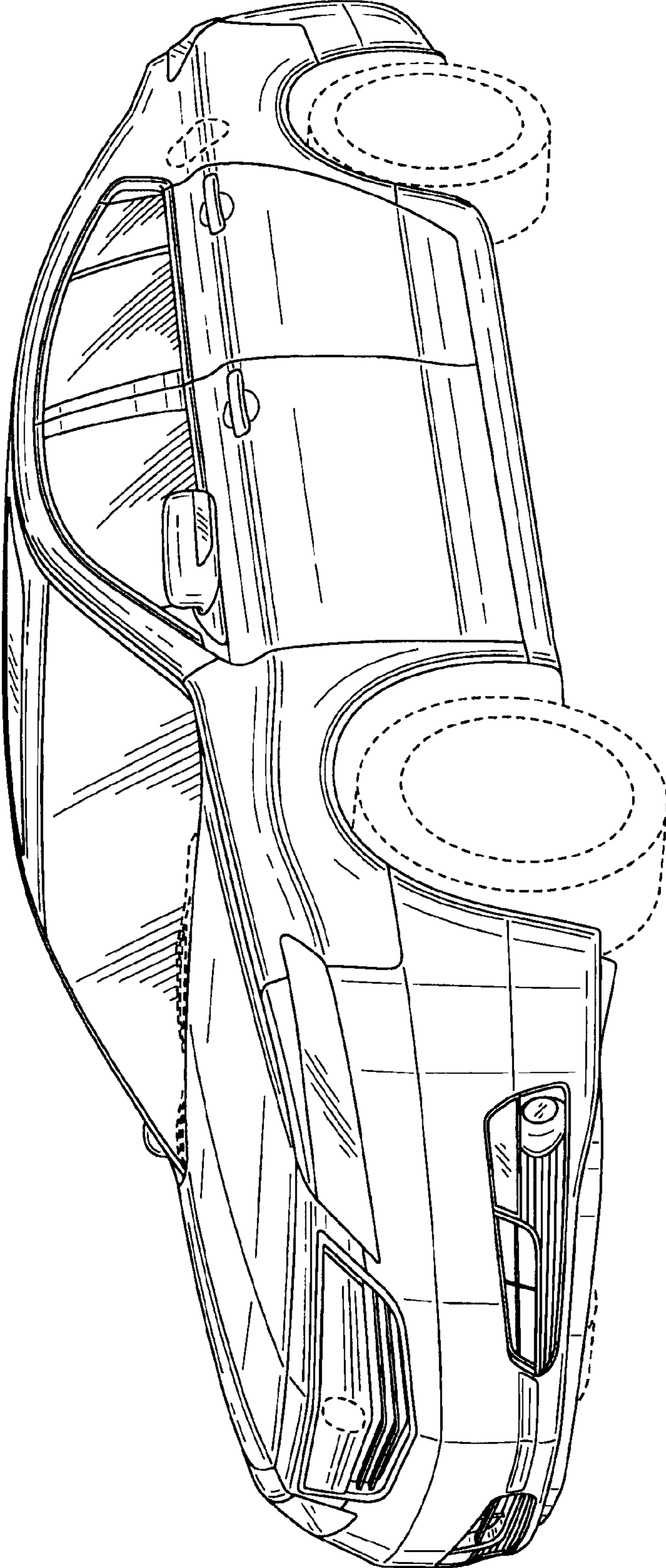

Fig. 1

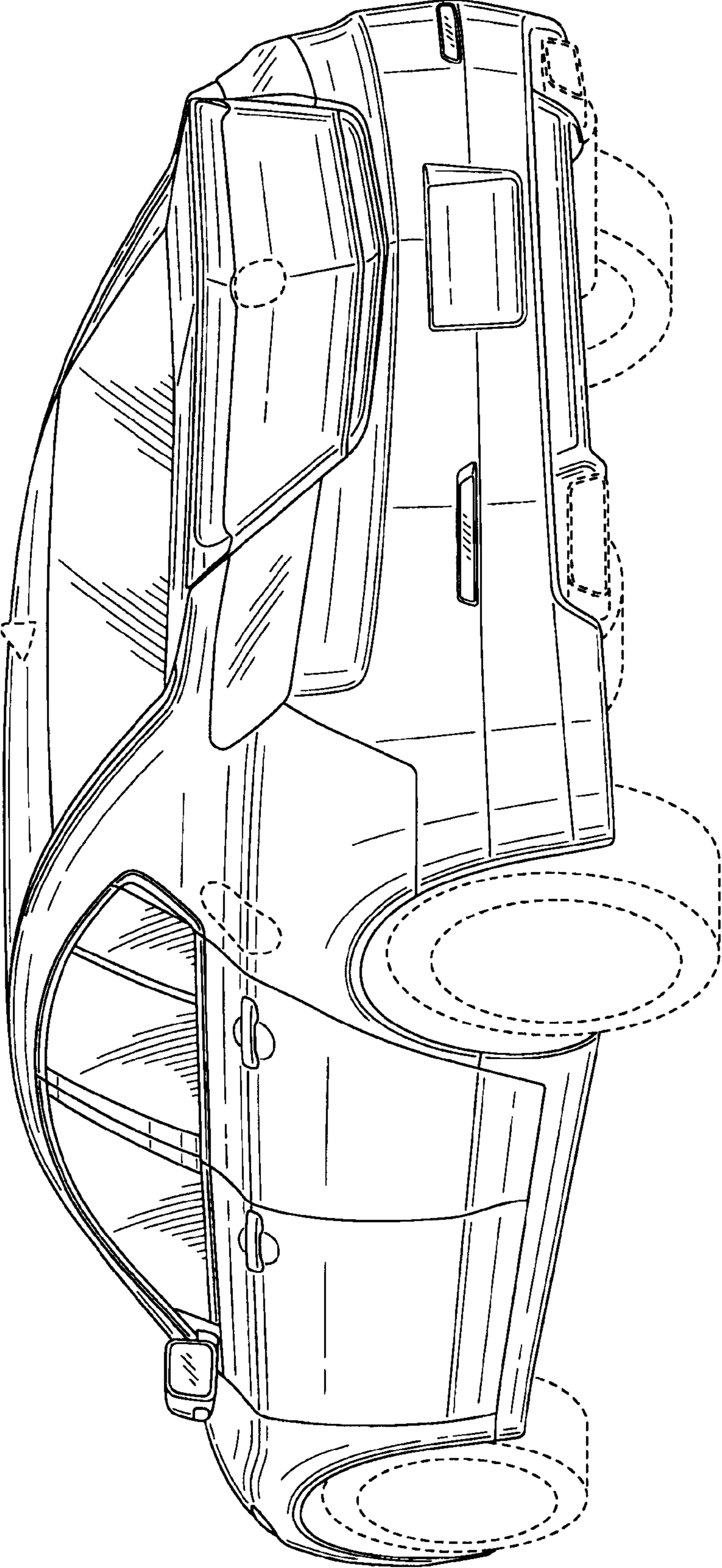

Fig. 2

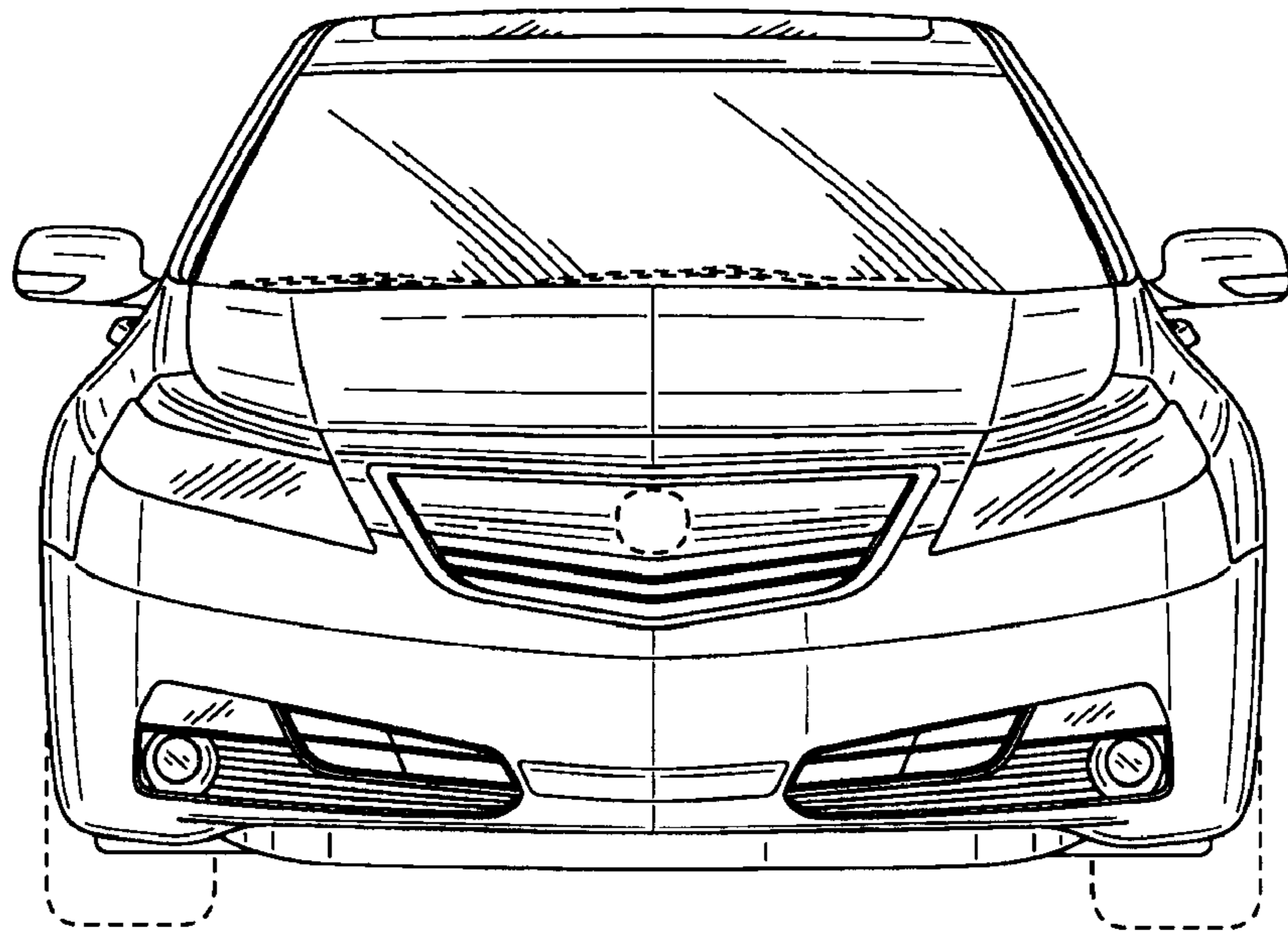

Fig. 3

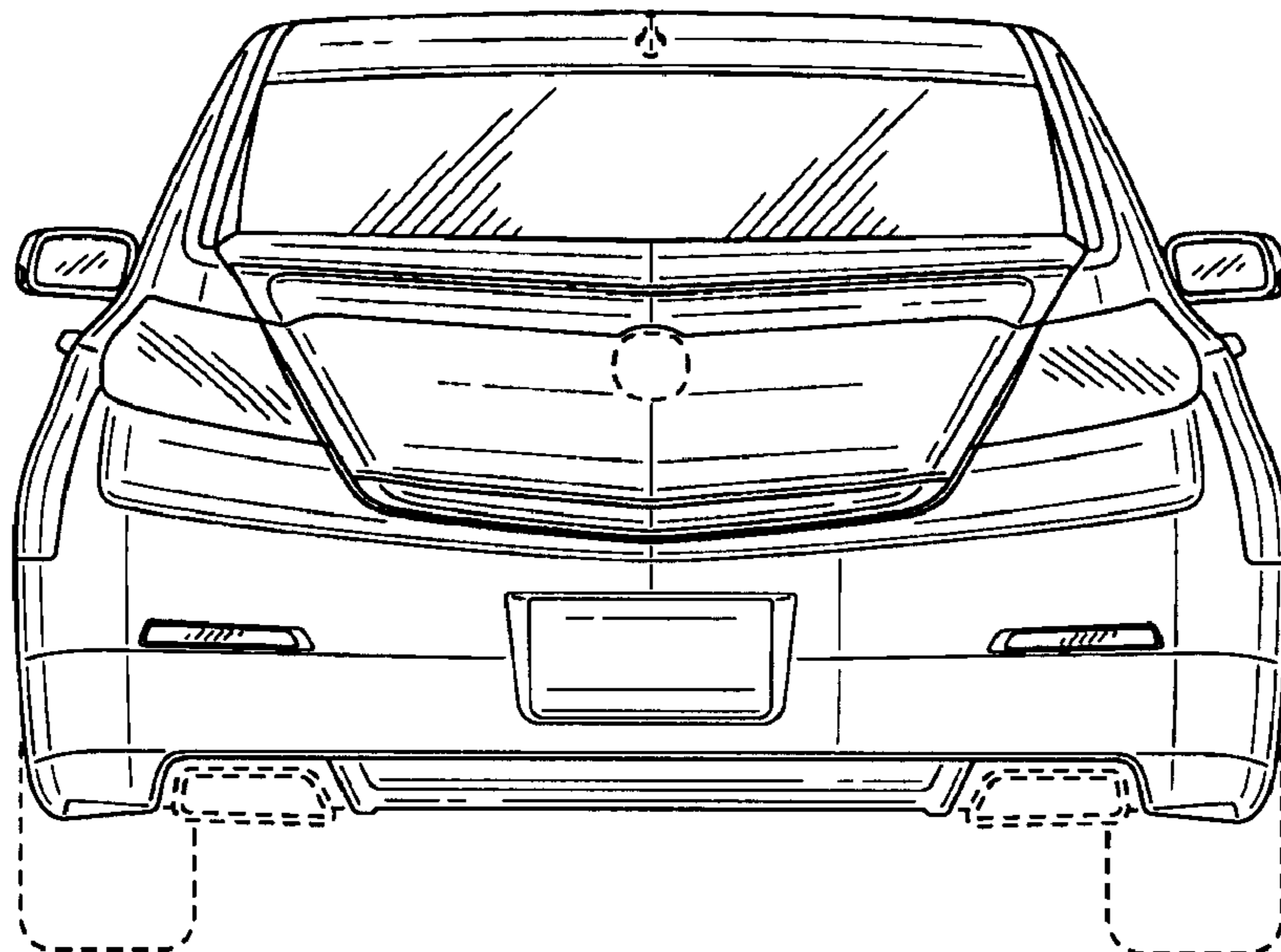

Fig. 4

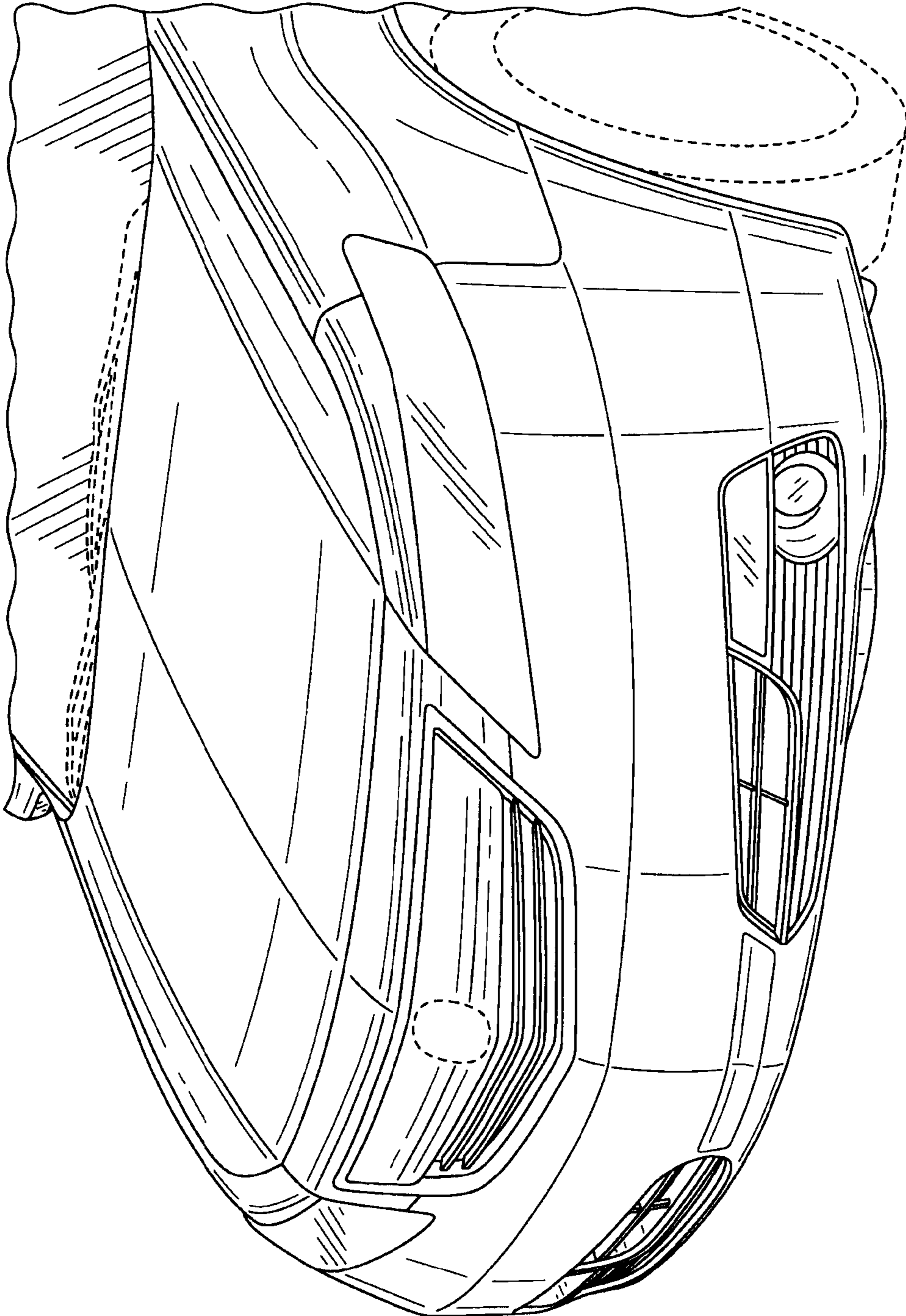

Fig. 5