

US00D647024S

(12) **United States Design Patent**
Tan

(10) **Patent No.:** **US D647,024 S**

(45) **Date of Patent:** **** Oct. 18, 2011**

(54) **GALLEY**

(75) Inventor: **Joyce Tan**, Hamburg (DE)

(73) Assignee: **Airbus Deutschland GmbH**, Hamburg (DE)

(**) Term: **14 Years**

(21) Appl. No.: **29/378,132**

(22) Filed: **Oct. 29, 2010**

Related U.S. Application Data

(62) Division of application No. 29/322,300, filed on Aug. 1, 2008.

(30) **Foreign Application Priority Data**

Feb. 21, 2008 (EM) 882956-0001
Feb. 21, 2008 (EM) 882956-0002
Feb. 21, 2008 (EM) 882956-0003

(51) **LOC (9) Cl.** **12-07**

(52) **U.S. Cl.** **D12/345**

(58) **Field of Classification Search** D26/2,
D26/88, 93, 103, 106, 69, 67, 66, 64, 63,
D26/65, 71, 75, 76, 80, 120, 121, 124, 128,
D26/118, 138, 142, 122, 113, 154, 156, 90,
D26/85, 86, 84, 81, 87; 362/183, 294, 295,
362/249.01-249.11; D13/102, 103, 179,
D13/180; D25/127, 129, 38; 361/704; 220/570,
220/695, 756; D9/430, 416, 424, 737; D32/53.1,
D32/53, 54; 244/118.5, 118.6; 297/245;
D6/356, 491, 492, 519, 580; D23/271, 286,
D23/234; D12/345; D8/349, 354, 373

See application file for complete search history.

(56) **References Cited**

U.S. PATENT DOCUMENTS

D90,873	S	*	10/1933	Dunning	D23/272
D163,754	S	*	6/1951	Haupt	D23/272
4,055,317	A	*	10/1977	Greiss	244/118.5
D277,698	S	*	2/1985	Newman	D24/177
D282,575	S	*	2/1986	Case et al.	D24/185
D288,267	S	*	2/1987	Meyer	D6/481
4,776,903	A	*	10/1988	Nordskog	156/64
4,840,000	A	*	6/1989	Grines	52/36.1
D331,100	S	*	11/1992	Jacobsen et al.	D23/271
D334,029	S	*	3/1993	Reising	D20/1
D344,830	S	*	3/1994	Carter et al.	D34/1
5,322,244	A	*	6/1994	Dallmann et al.	244/118.5
D357,062	S	*	4/1995	Schreiner	D23/272
6,243,993	B1	*	6/2001	Swensson	52/79.5
D457,249	S	*	5/2002	Gilbert	D24/234
6,761,332	B1	*	7/2004	Bengtsson	244/118.5
D507,285	S	*	7/2005	Cho et al.	D15/86
7,331,544	B1	*	2/2008	Harrington et al.	244/118.1
2001/0050519	A1	*	12/2001	Kasuya	312/315
2006/0060181	A1	*	3/2006	Sasaki et al.	126/21 A
2006/0145002	A1	*	7/2006	Van Loon	244/118.1

* cited by examiner

Primary Examiner — Cathron Brooks

Assistant Examiner — Kevin Rudzinski

(74) *Attorney, Agent, or Firm* — Perman & Green, LLP

(57) **CLAIM**

The ornamental design for a galley, as shown and described.

DESCRIPTION

FIG. 1 is a front view of the galley, including a storage unit comprising single and double sized compartments and a retractable table;

FIG. 2 is a side view thereof with the table retracted;

FIG. 3 is a side view thereof with the table deployed; and,

FIG. 4 is a perspective view thereof with the table deployed.

The design relates to an aircraft galley including a beverage unit, a storage unit and preparation unit. It is designed for storing and preparing food by flight attendants.

1 Claim, 4 Drawing Sheets

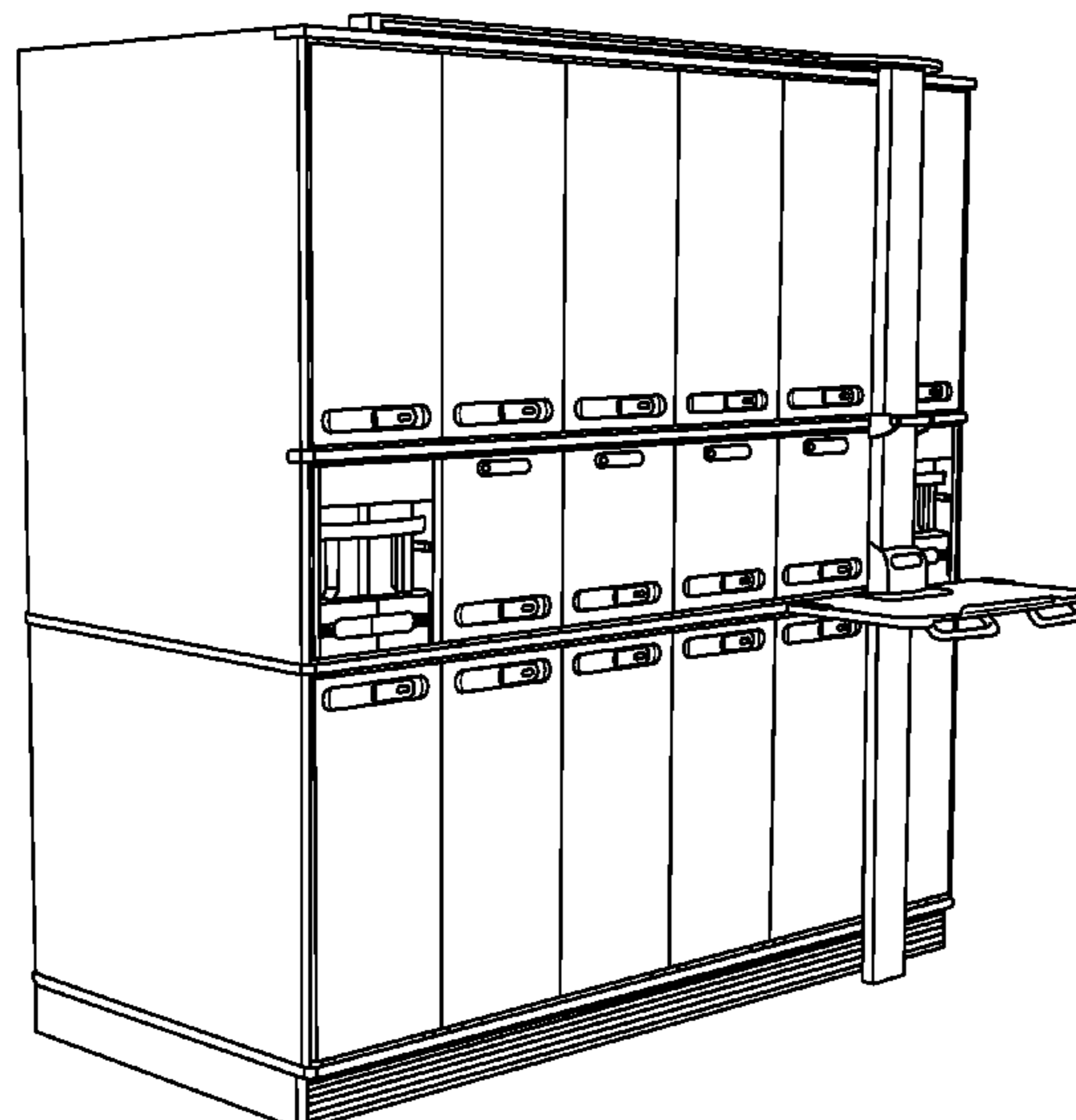

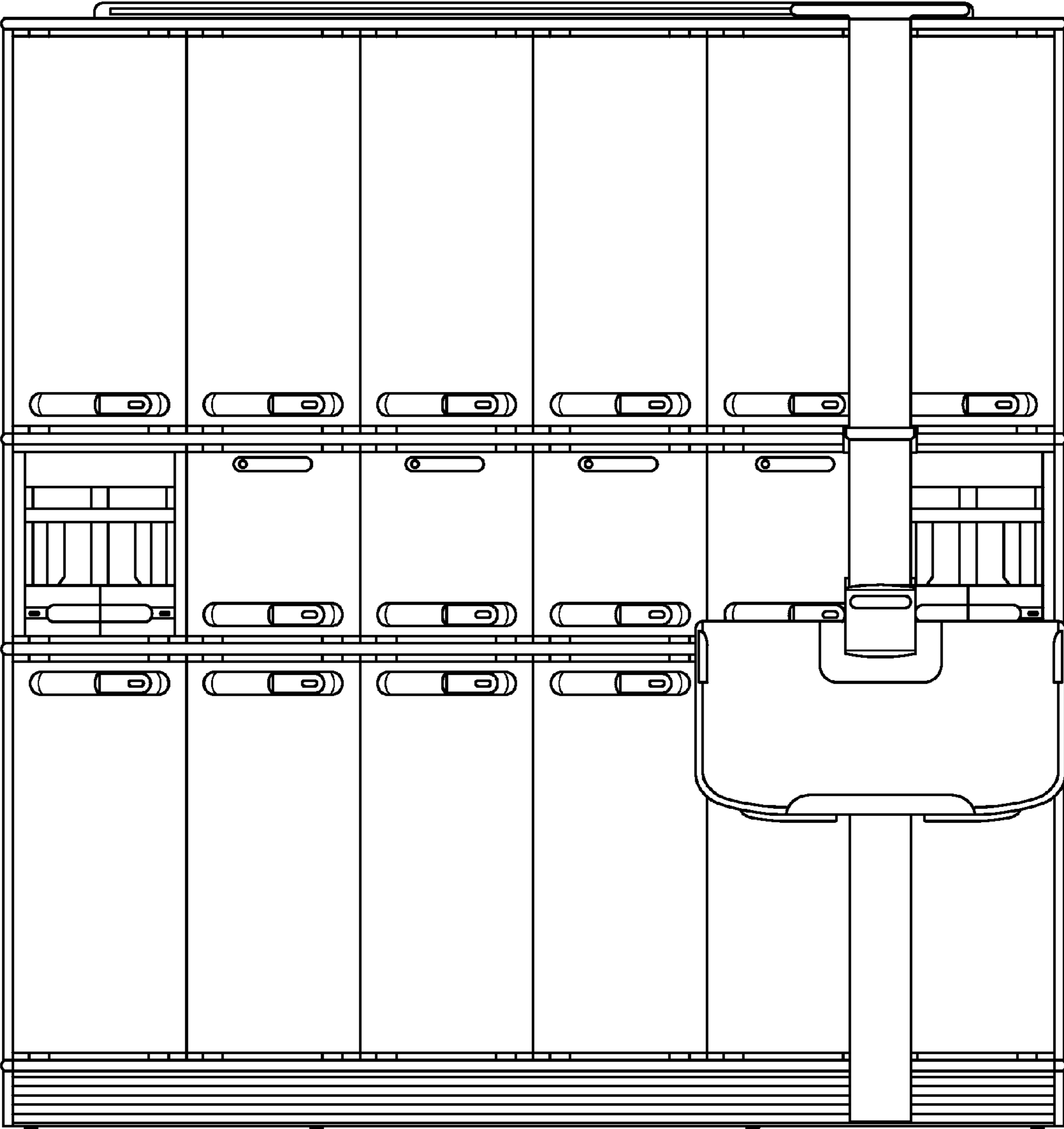

FIG. 1

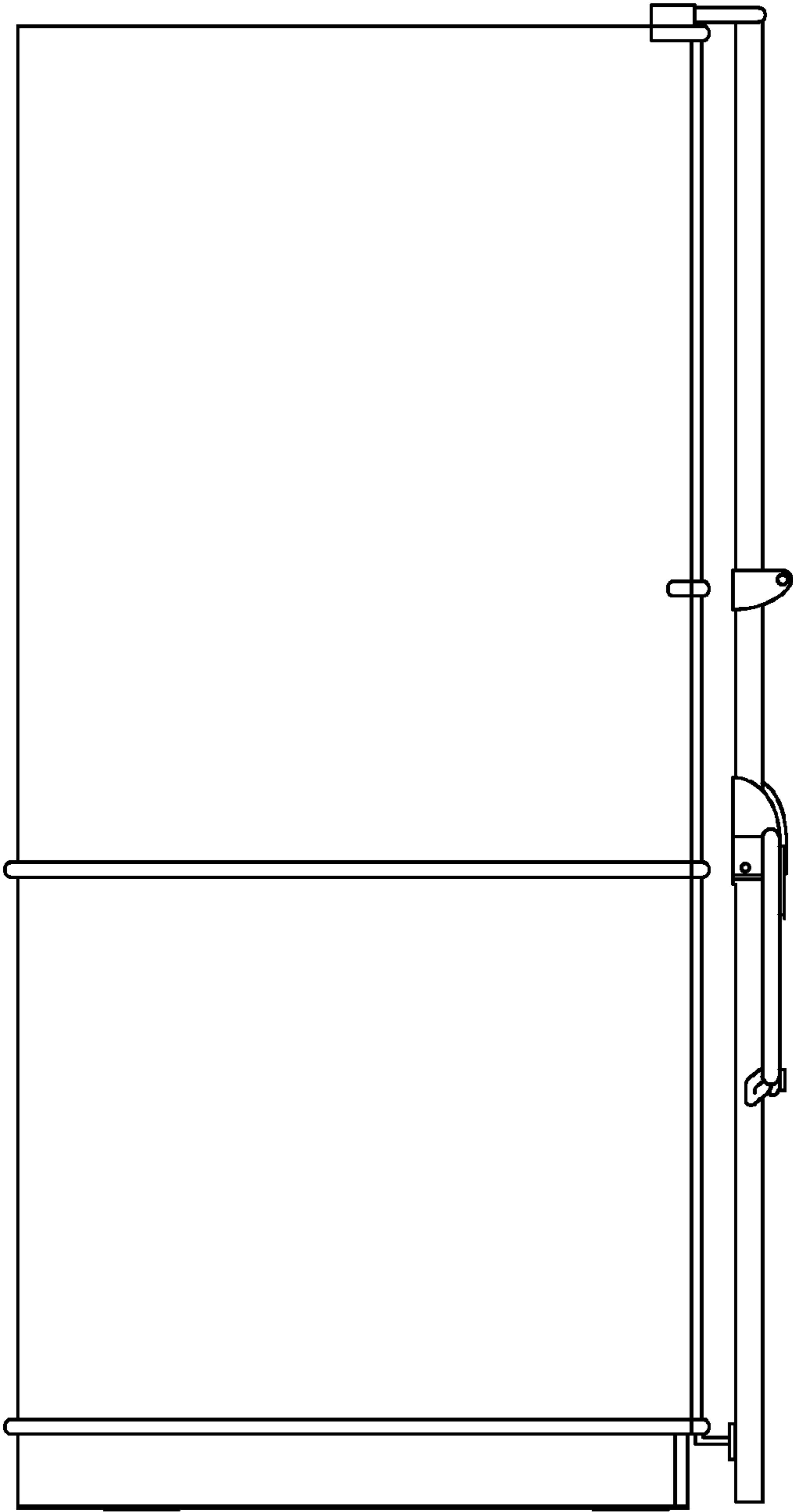

FIG. 2

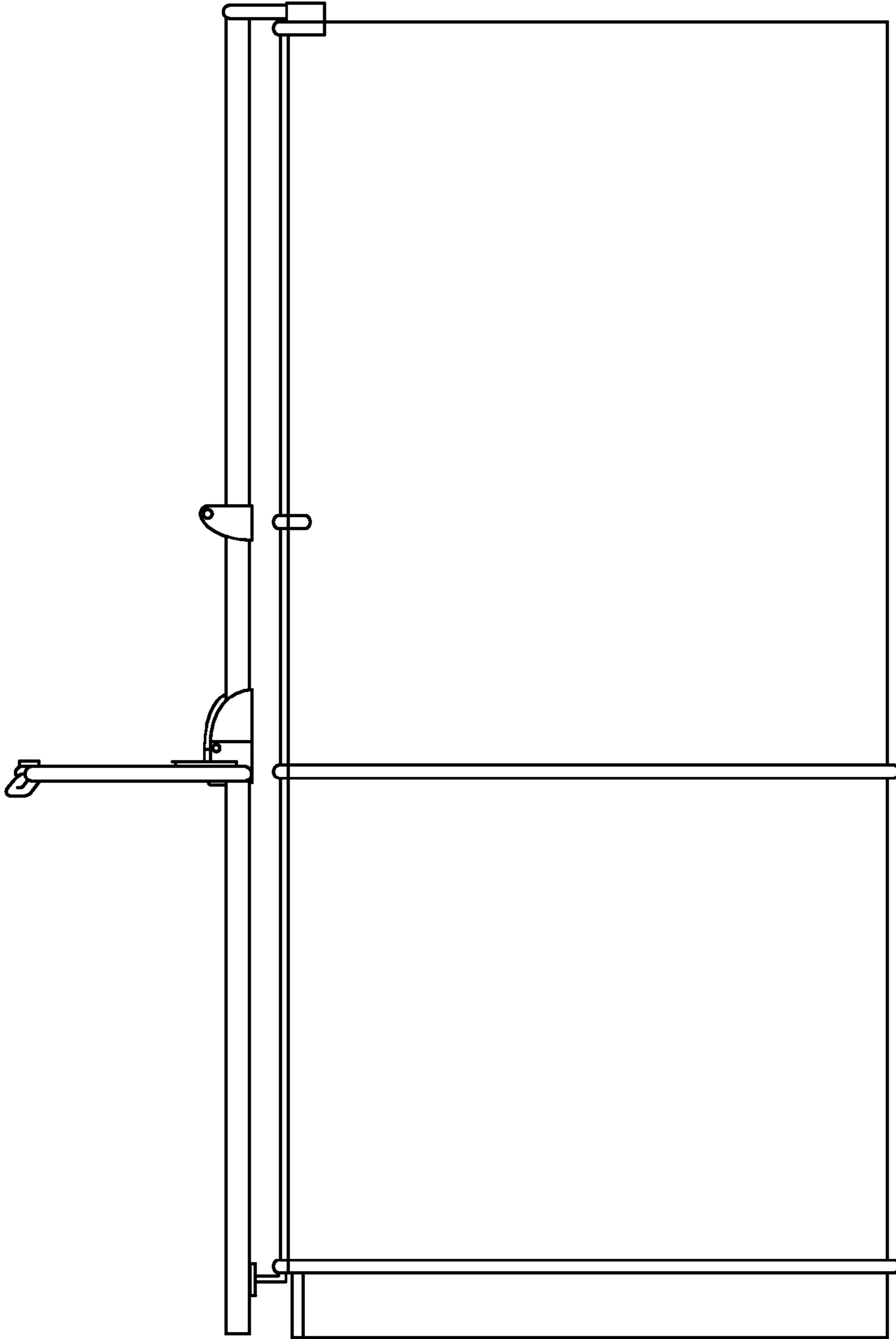

FIG. 3

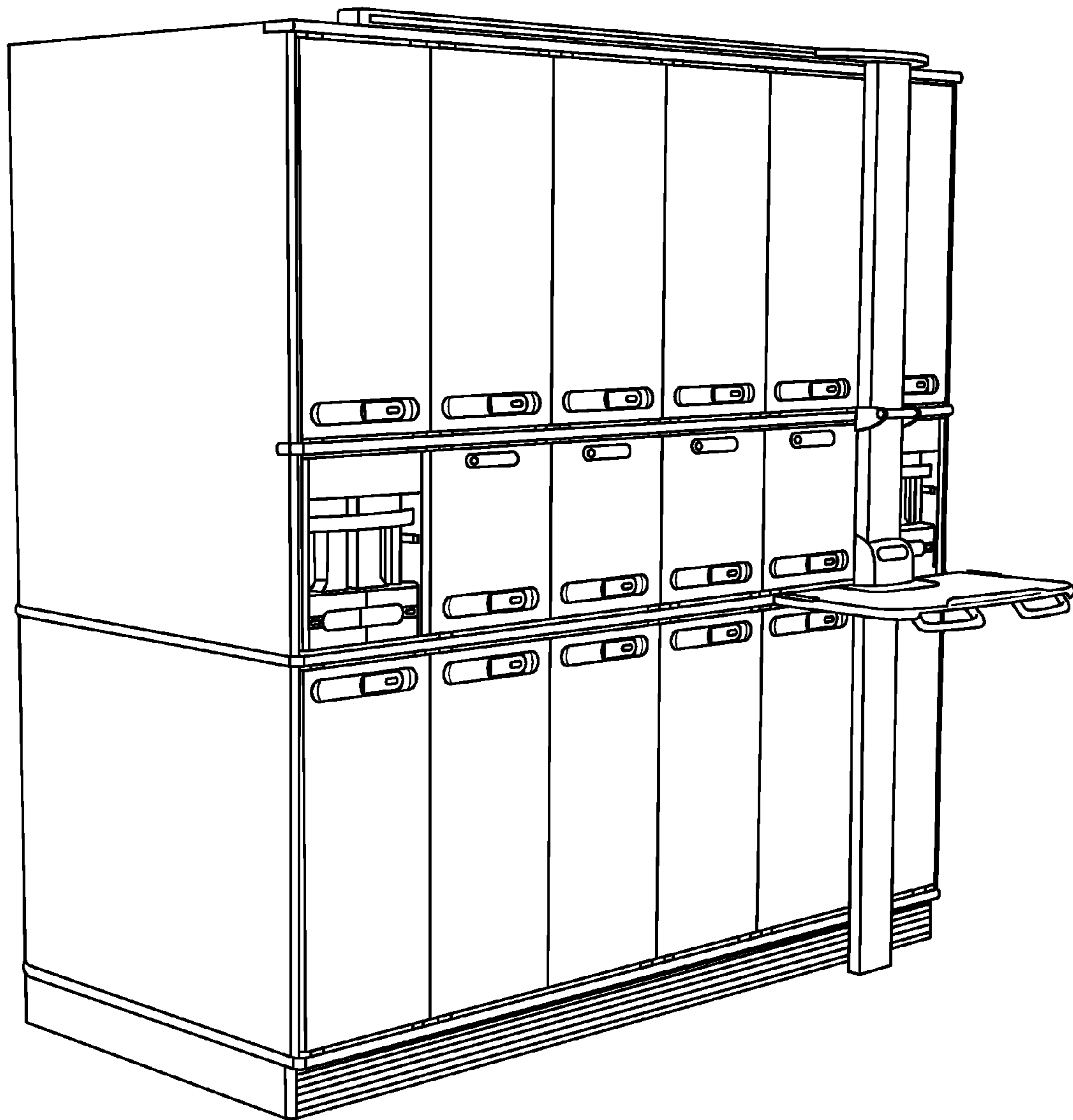

FIG. 4