



US00D647002S

(12) **United States Design Patent**
Mullen

(10) **Patent No.:** **US D647,002 S**
(45) **Date of Patent:** **** Oct. 18, 2011**

(54) **VEHICLE**

(75) Inventor: **Michael Mullen**, Weybridge (GB)

(73) Assignee: **Jankel Armouring Limited**, Weybridge (GB)

(**) Term: **14 Years**

(21) Appl. No.: **29/386,586**

(22) Filed: **Mar. 2, 2011**

(30) **Foreign Application Priority Data**

Feb. 3, 2011 (EM) 001815853

(51) **LOC (9) Cl.** **12-08**

(52) **U.S. Cl.** **D12/86**

(58) **Field of Classification Search** D12/86,
D12/87, 1; D21/424, 433; 296/181.1, 181.5
See application file for complete search history.

(56) **References Cited**

U.S. PATENT DOCUMENTS

D638,333 S * 5/2011 Freeman D12/86
D642,091 S * 7/2011 Karacabey et al. D12/82

* cited by examiner

Primary Examiner — Melody N Brown

(74) *Attorney, Agent, or Firm* — Winstead PC

(57) **CLAIM**

The ornamental design for a vehicle, as shown and described.

DESCRIPTION

FIG. 1 is a left-side elevation view of a vehicle in accordance with the design;

FIG. 2 is a right-side elevation view of the vehicle in accordance with the design;

FIG. 3 is a top plan view of the vehicle in accordance with the design;

FIG. 4 is a rear elevation view of the vehicle in accordance with the design;

FIG. 5 is a front elevation view of the vehicle in accordance with the design; and,

FIG. 6 is a perspective view of the vehicle in accordance with the design.

The portions of the vehicle shown in broken lines are for illustrative purposes only and form no part of the claimed design.

1 Claim, 6 Drawing Sheets

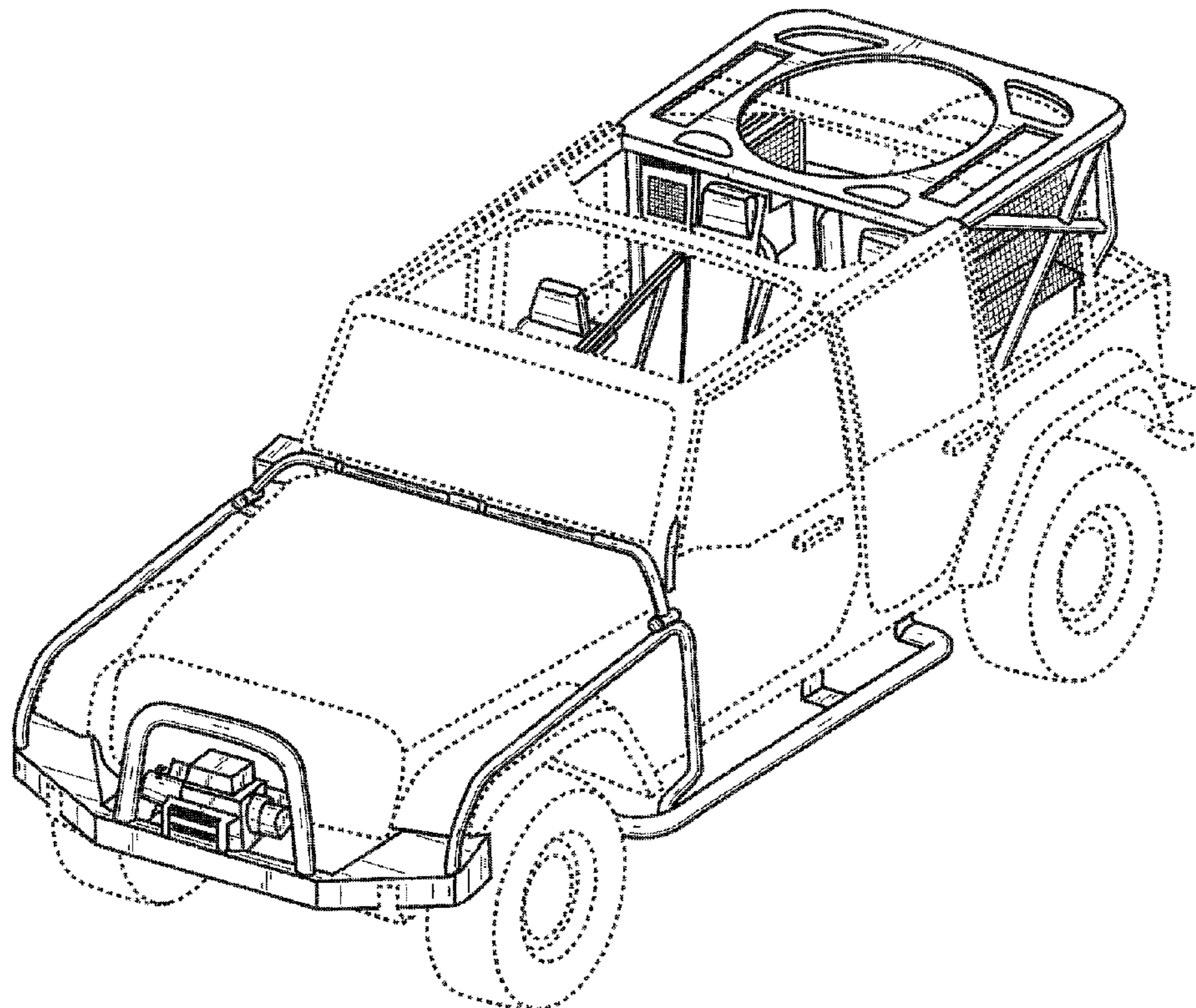

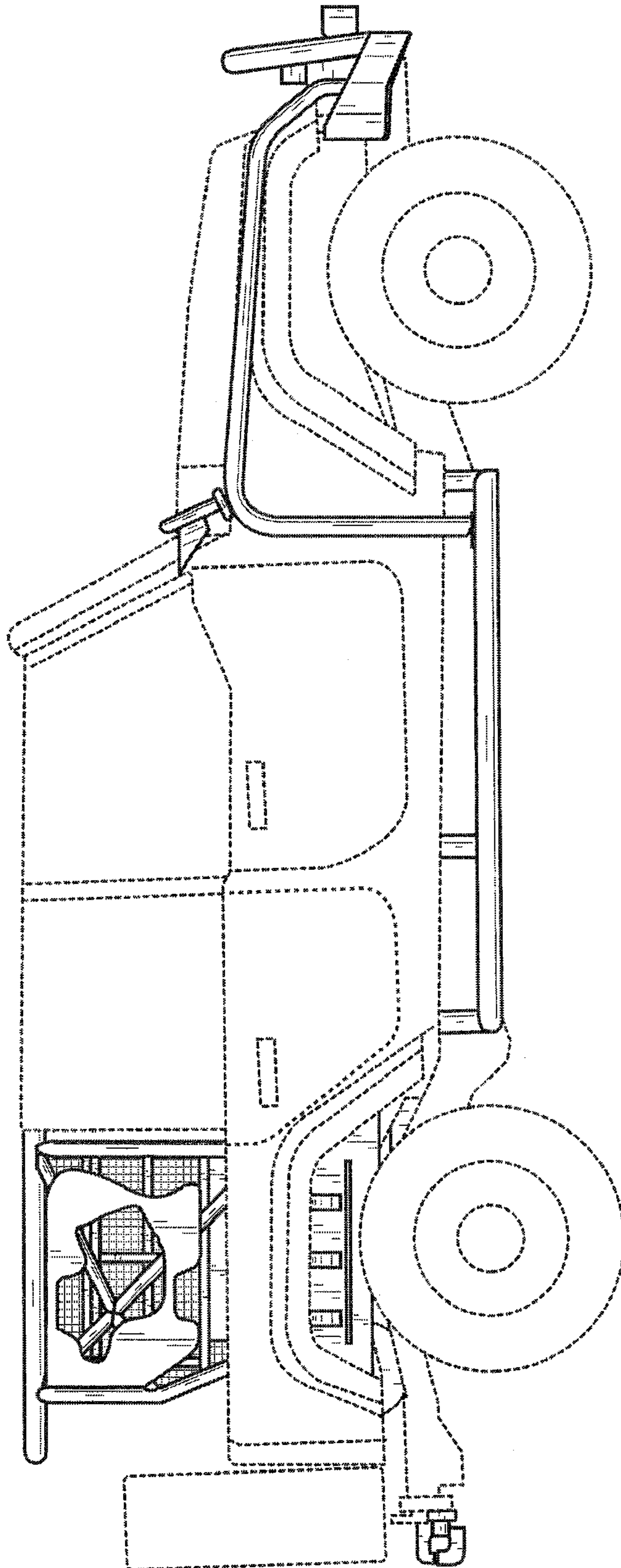

FIG. 1

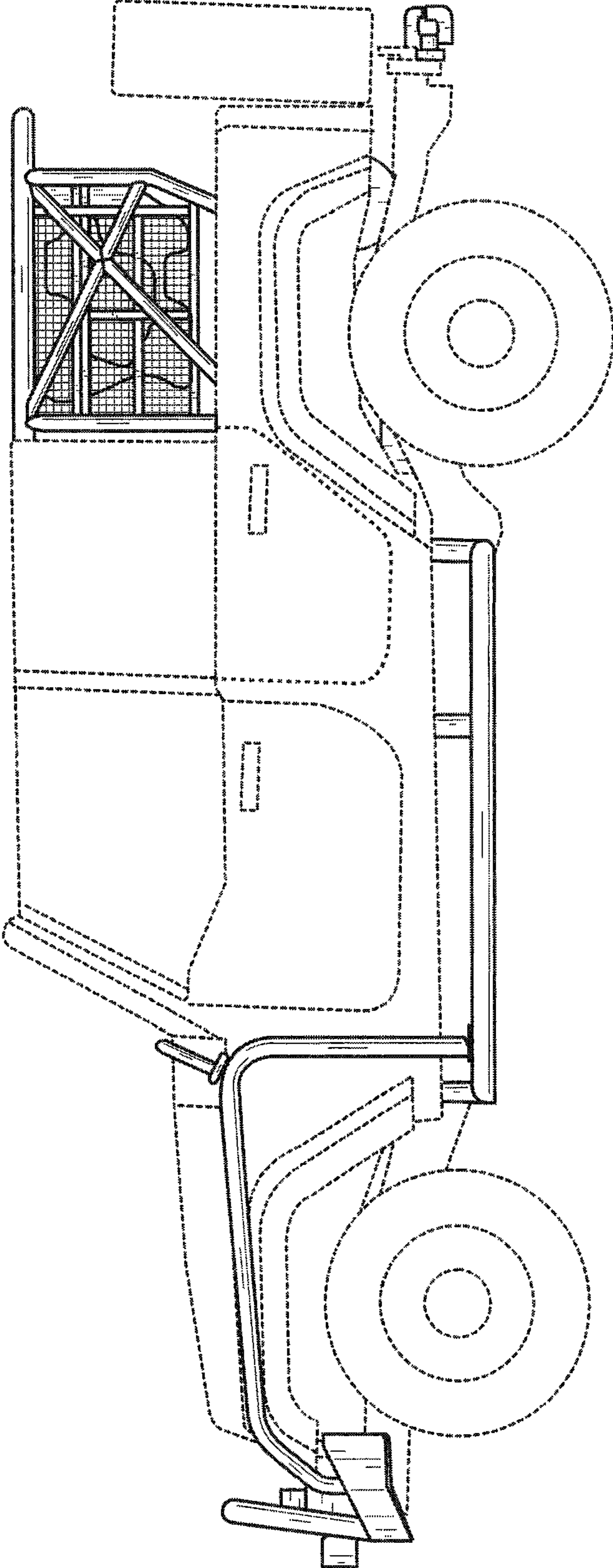

FIG. 2

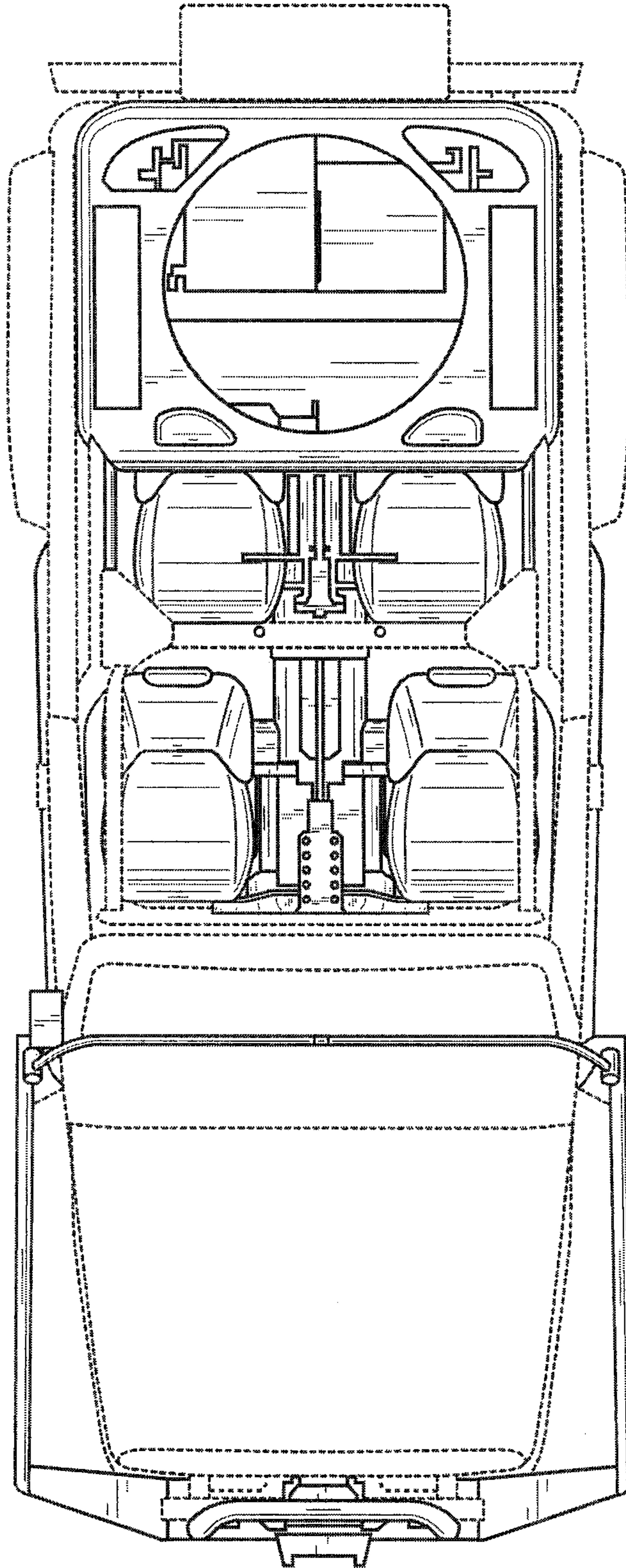

FIG. 3

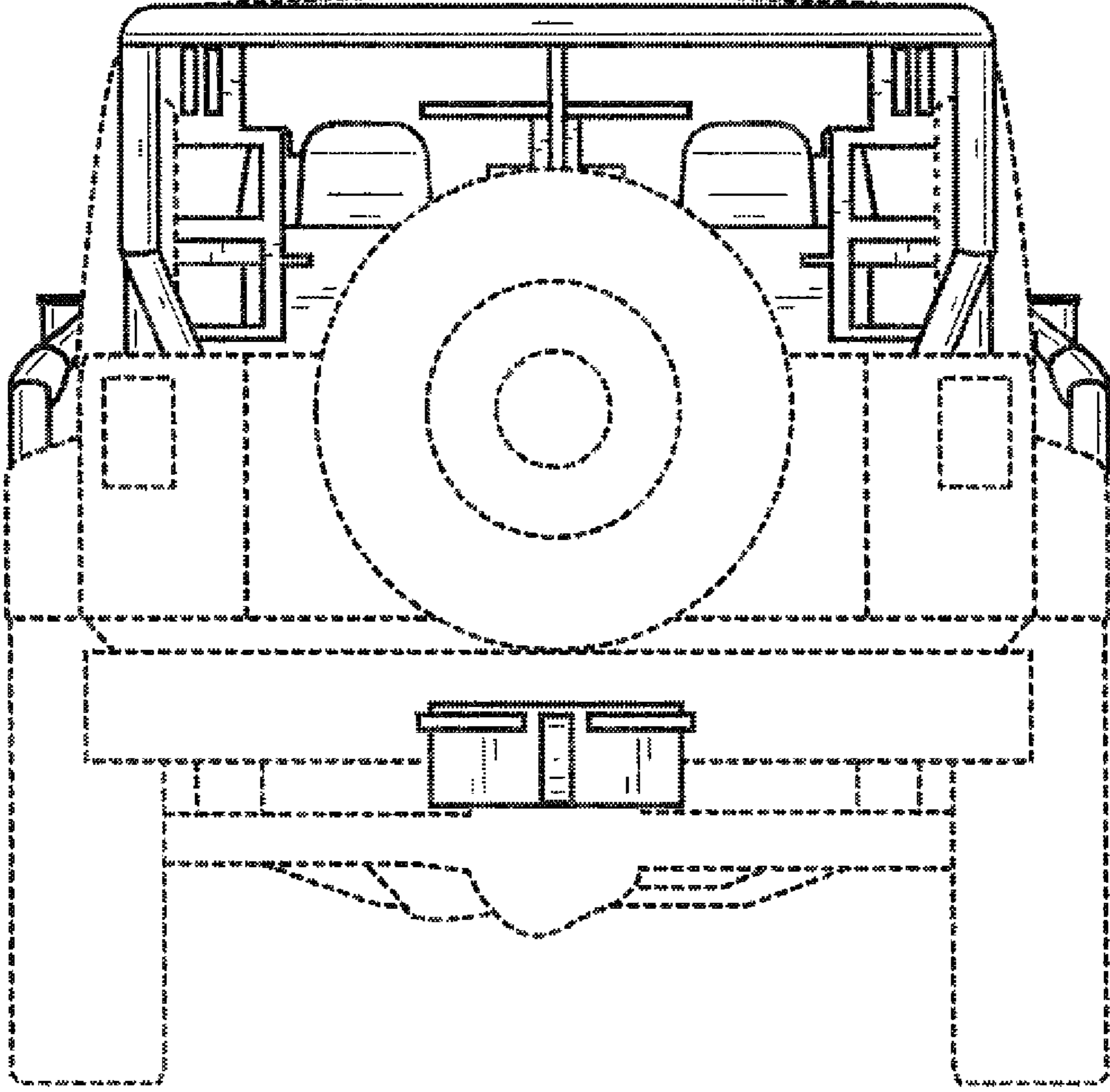

FIG. 4

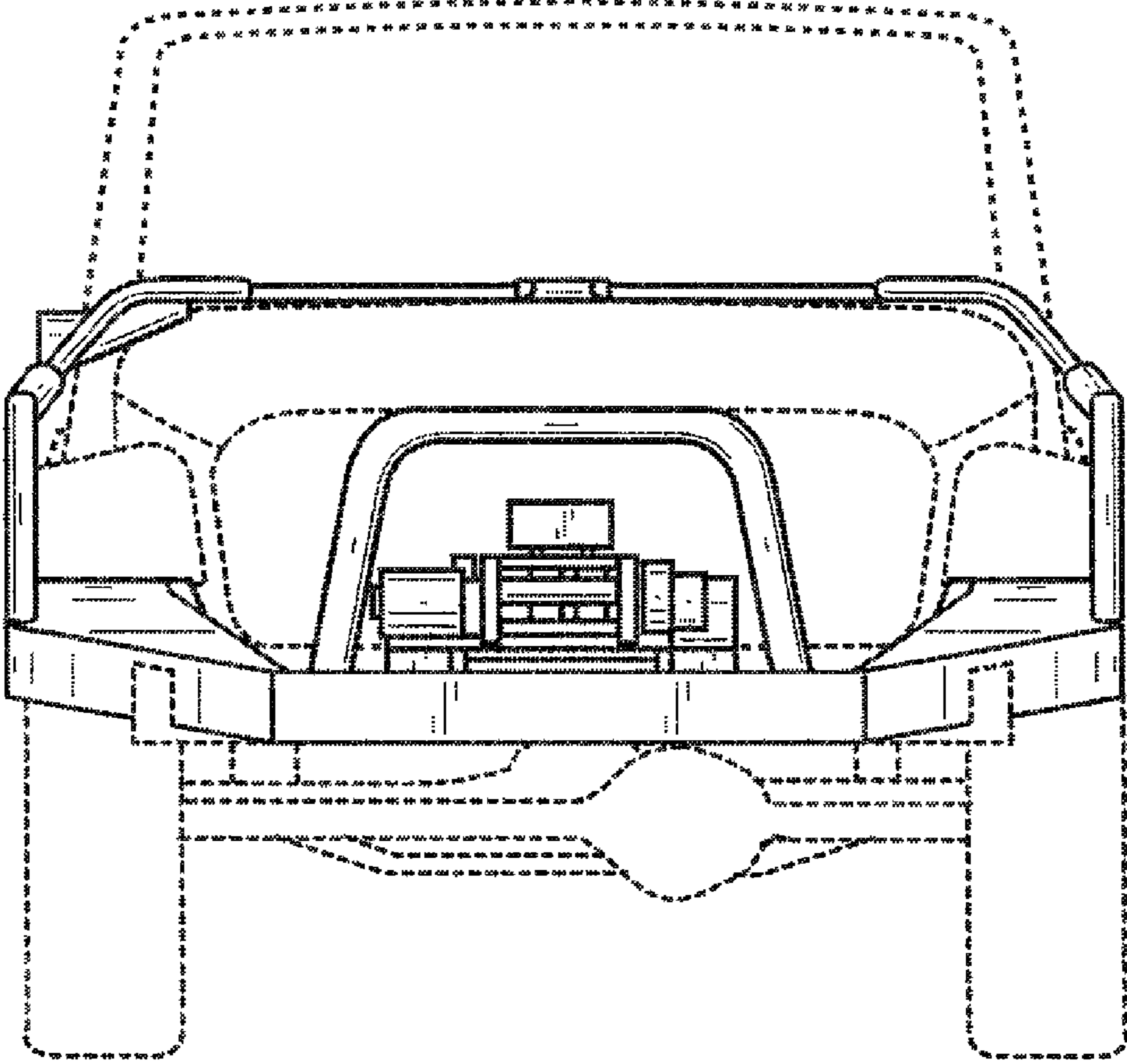

FIG. 5

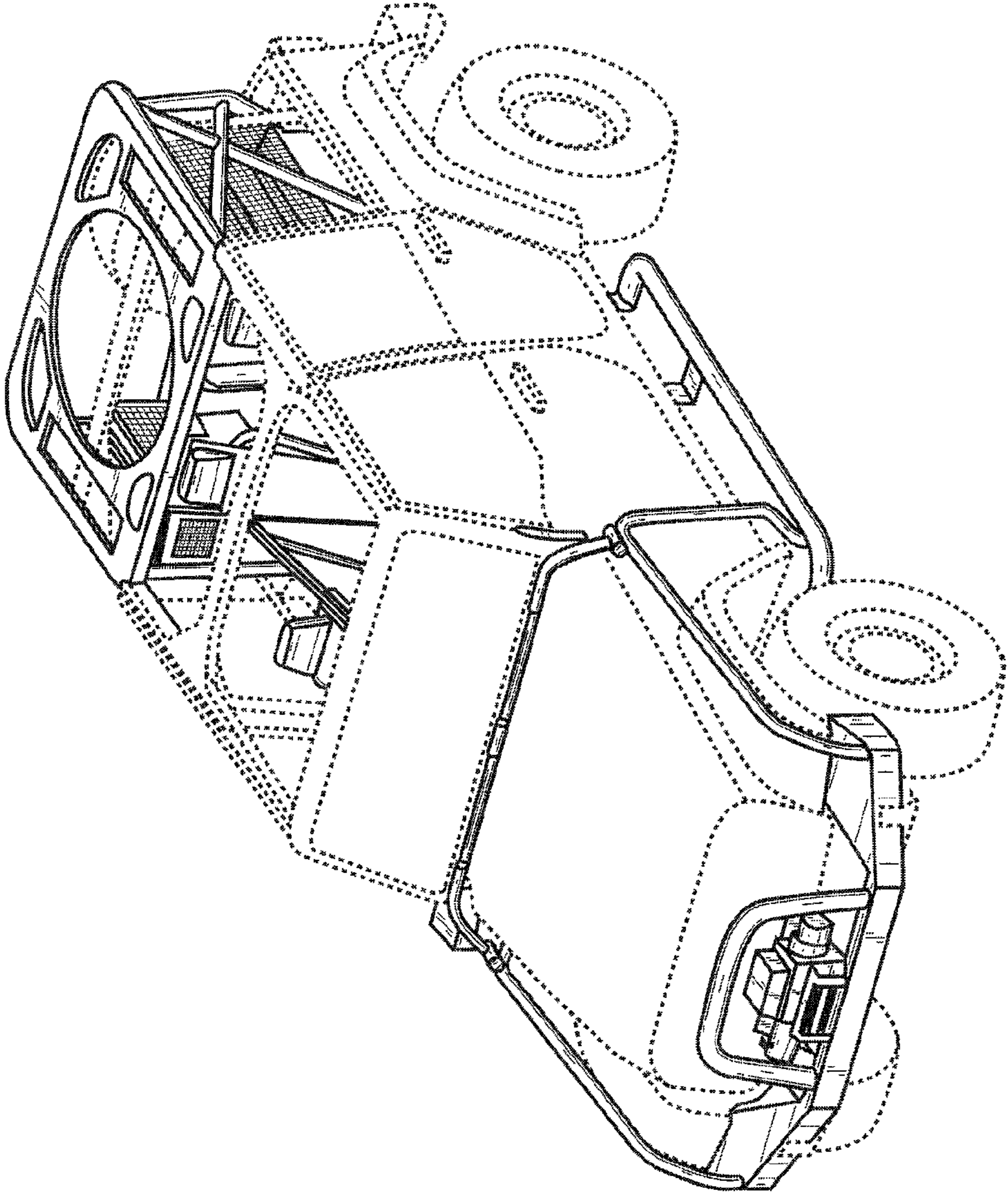

FIG. 6