



US00D646946S

(12) **United States Design Patent**  
**Bhasin**

(10) **Patent No.:** **US D646,946 S**

(45) **Date of Patent:** **\*\* Oct. 18, 2011**

(54) **SCISSORS**

(75) Inventor: **Hanuman Prasad Bhasin**, Suita (JP)

(73) Assignee: **B.H.P. Industries Co., Ltd.**, Suita-shi (JP)

(\*\*) Term: **14 Years**

(21) Appl. No.: **29/380,877**

(22) Filed: **Dec. 13, 2010**

(30) **Foreign Application Priority Data**

Aug. 19, 2010 (JP) ..... 2010-020068

(51) **LOC (9) Cl.** ..... **08-03**

(52) **U.S. Cl.** ..... **D8/57**

(58) **Field of Classification Search** ..... D8/4, 5,  
D8/51-58, 105-107; D7/693; 7/135-136;  
30/131, 194, 195, 229-235, 254-258, 268,  
30/350, 341

See application file for complete search history.

(56) **References Cited**

**U.S. PATENT DOCUMENTS**

D51,180 S *	8/1917	Koehler	.....	D8/57
1,681,691 A *	8/1928	Altenbach	.....	7/123
D242,425 S *	11/1976	Backstrom	.....	D8/57
D264,677 S *	6/1982	Perry, Jr.	.....	D8/57
D269,207 S *	5/1983	Marlowe	.....	D24/143
D297,206 S *	8/1988	Hayashi	.....	D8/57
D331,867 S *	12/1992	Rommerdale	.....	D8/57
D333,416 S *	2/1993	Brown, Jr.	.....	D8/57
D337,249 S *	7/1993	Williams	.....	D8/57
6,050,269 A *	4/2000	Park	.....	132/73
D442,046 S *	5/2001	Huang	.....	D8/57
D461,109 S *	8/2002	Kurz	.....	D8/57
D523,714 S *	6/2006	Peterson et al.	.....	D8/57
D537,310 S *	2/2007	McLean	.....	D8/57

D543,080 S *	5/2007	Haquin	.....	D8/57
D554,458 S *	11/2007	Wittke-Kothe	.....	D8/57
D554,459 S *	11/2007	Garland et al.	.....	D8/57
D554,961 S *	11/2007	Kurz	.....	D8/57
D567,044 S *	4/2008	Opolka	.....	D8/57
D569,701 S *	5/2008	Haquin	.....	D8/57
D591,123 S *	4/2009	Peterson et al.	.....	D8/57
D613,141 S *	4/2010	Wang	.....	D8/57
D632,938 S *	2/2011	Papenfuss	.....	D8/57

\* cited by examiner

*Primary Examiner* — Cathron Brooks

*Assistant Examiner* — Deanna Fluegeman

(74) *Attorney, Agent, or Firm* — W. F. Fasse; W. G. Fasse

(57) **CLAIM**

The ornamental design for a scissors, as shown and described.

**DESCRIPTION**

FIG. 1 is a front view of a scissors showing my new design;  
 FIG. 2 is a rear view thereof;  
 FIG. 3 is a top plan view thereof;  
 FIG. 4 is a bottom plan view thereof;  
 FIG. 5 is a left side view thereof;  
 FIG. 6 is a right side view thereof;  
 FIG. 7 is an end view of the sectioned part taken along the  
 arrowed line A-A thereof;  
 FIG. 8 is an end view of the sectioned part taken along the  
 arrowed line B-B thereof;  
 FIG. 9 is an end view of the sectioned part taken along the  
 arrowed line C-C thereof;  
 FIG. 10 is an end view of the sectioned part taken along the  
 arrowed line D-D thereof;  
 FIG. 11 is an enlarged view of the portion indicated by the  
 lines E-E thereof;  
 FIG. 12 is an enlarged view of the portion indicated by the line  
 F-F thereof; and,  
 FIG. 13 is a front view thereof showing the opened state.

**1 Claim, 7 Drawing Sheets**

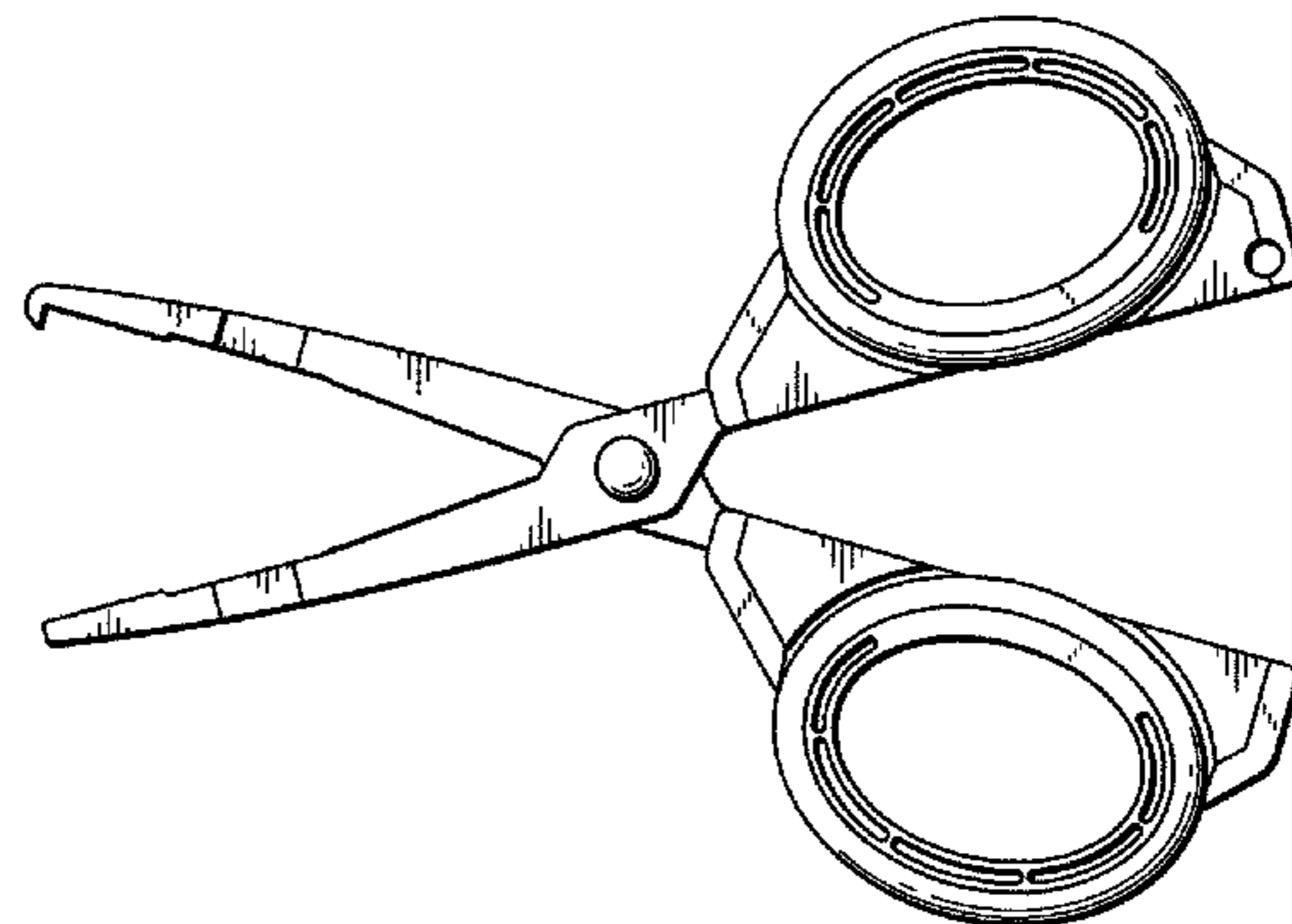
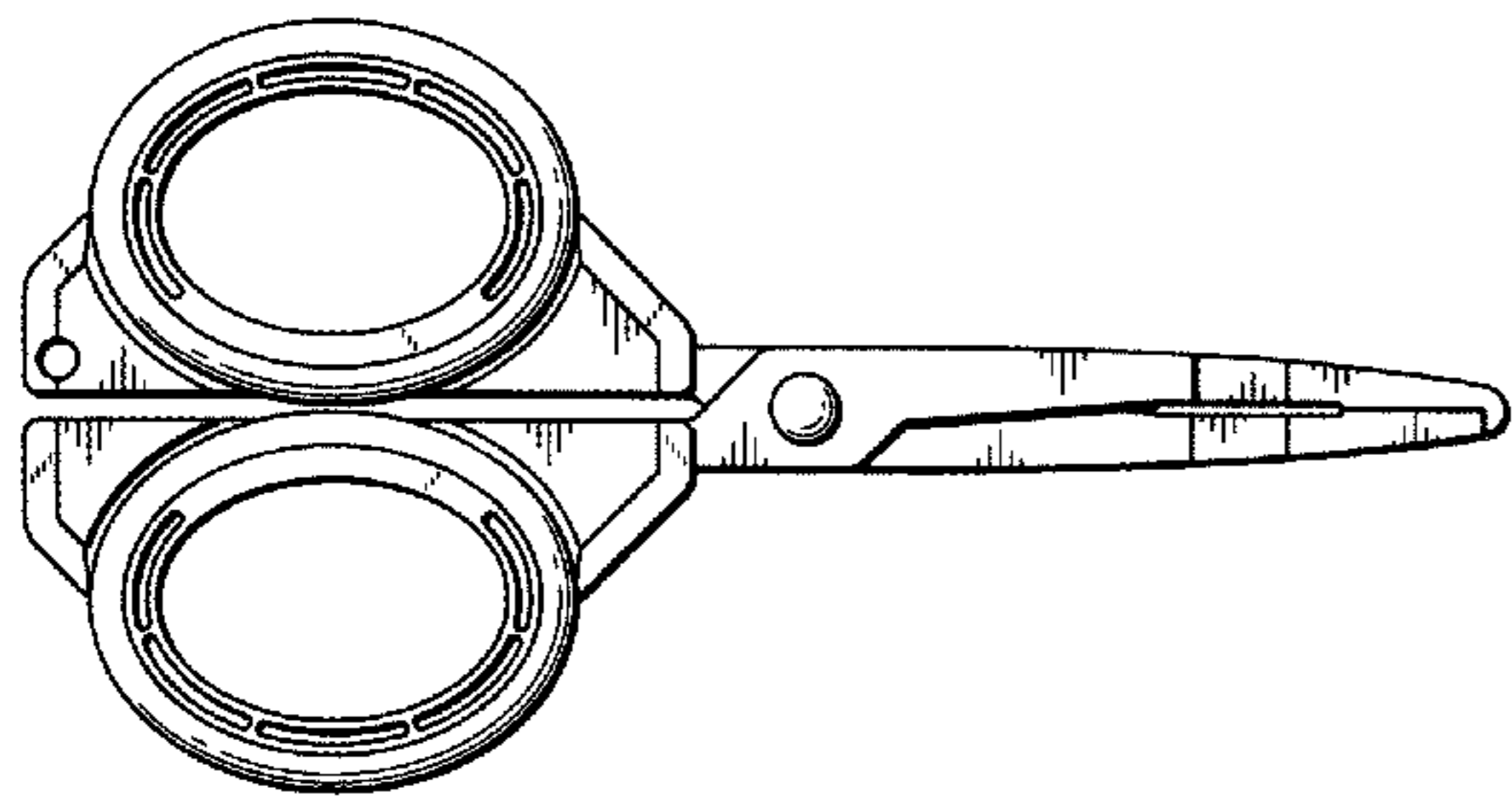

FIG.1

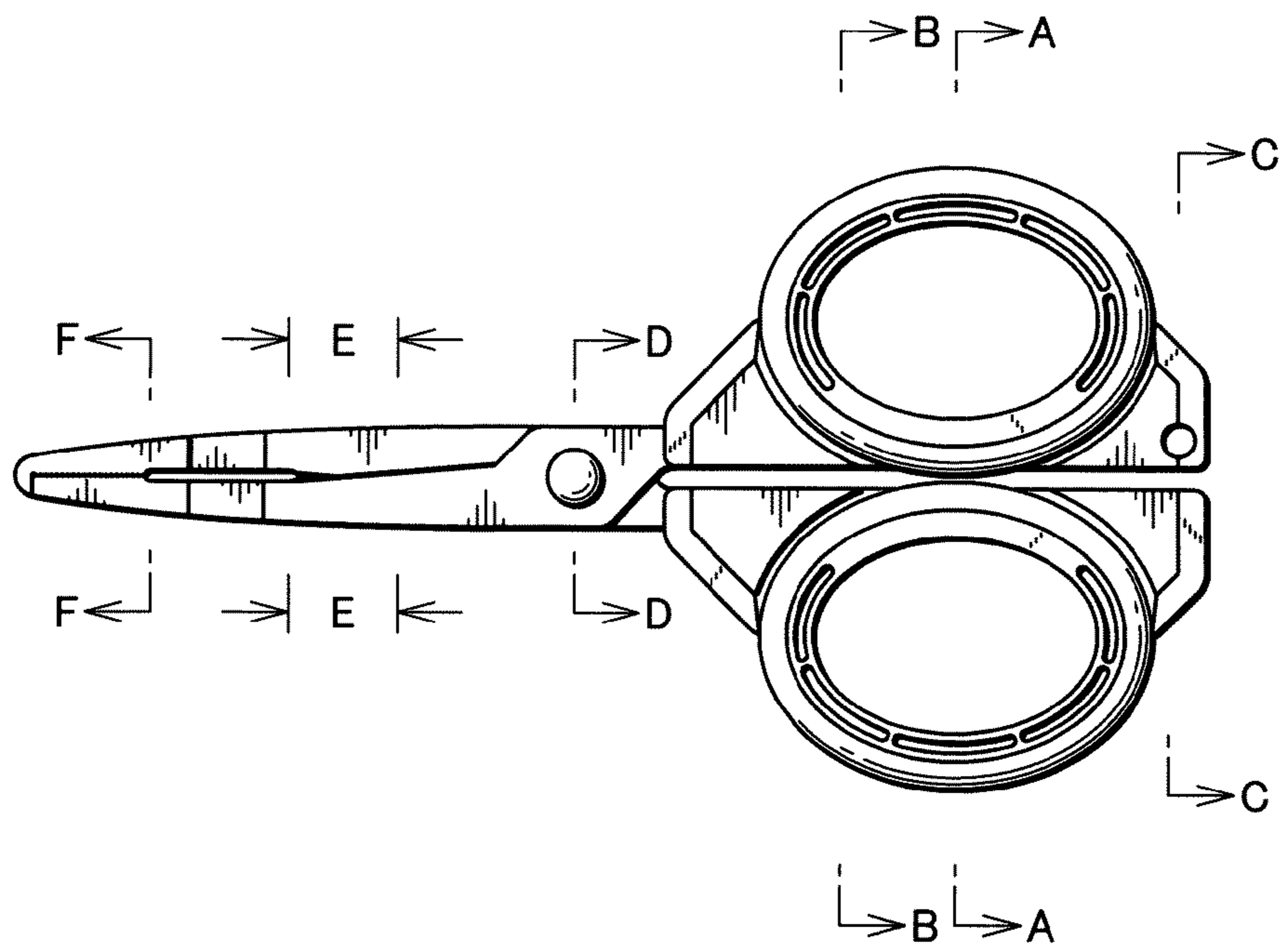

FIG.2

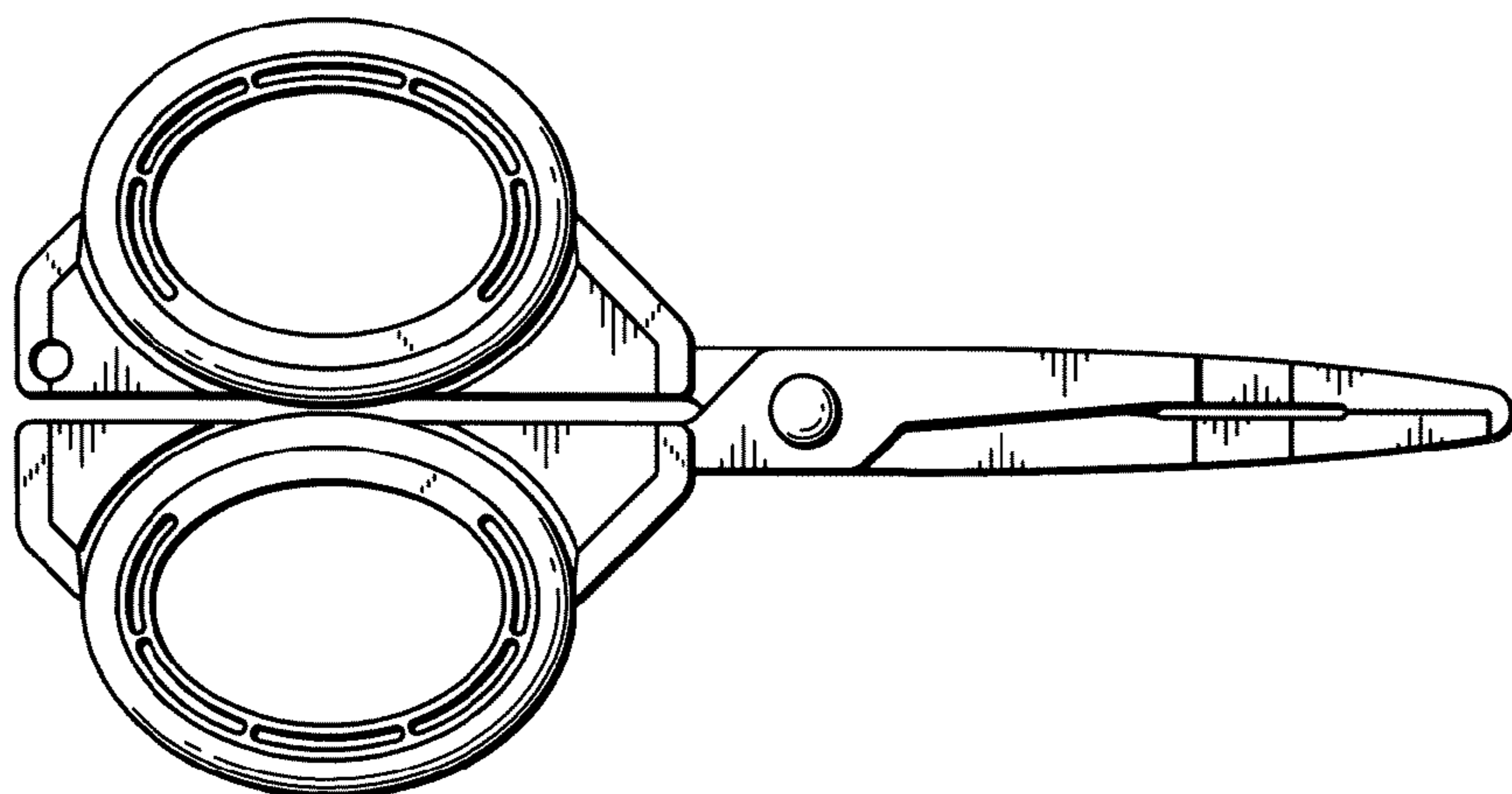

FIG.3



FIG.4

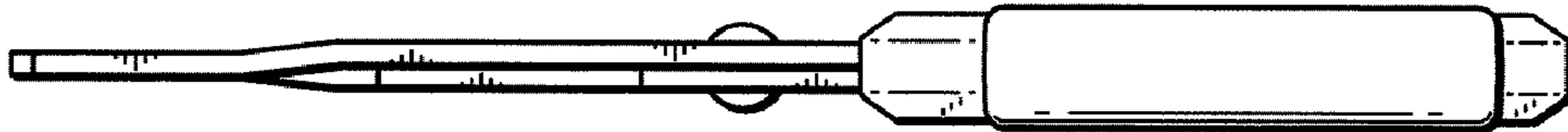

FIG.5



FIG.6



FIG. 7



FIG. 8



FIG.9



FIG.10



FIG.11

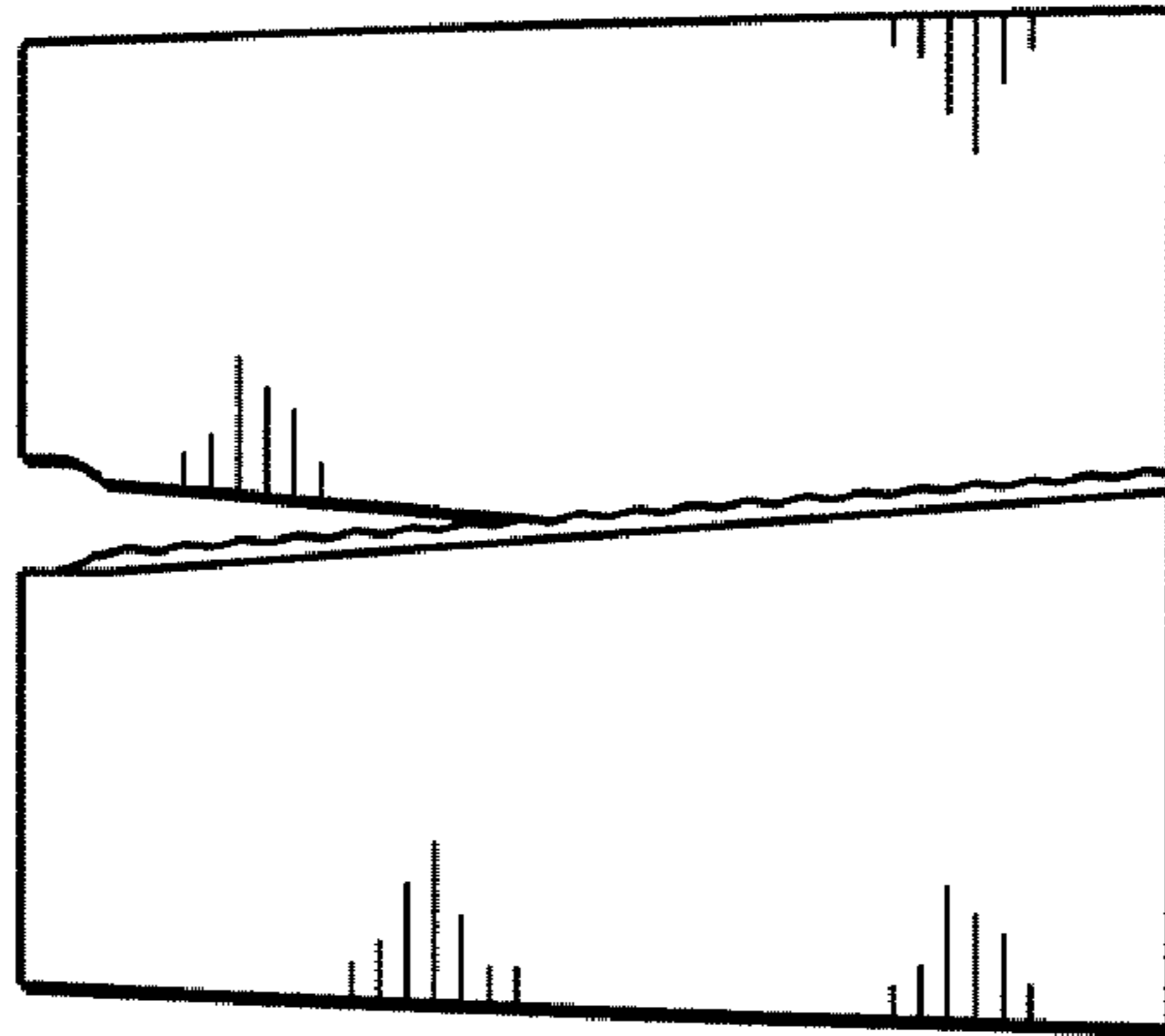

FIG.12

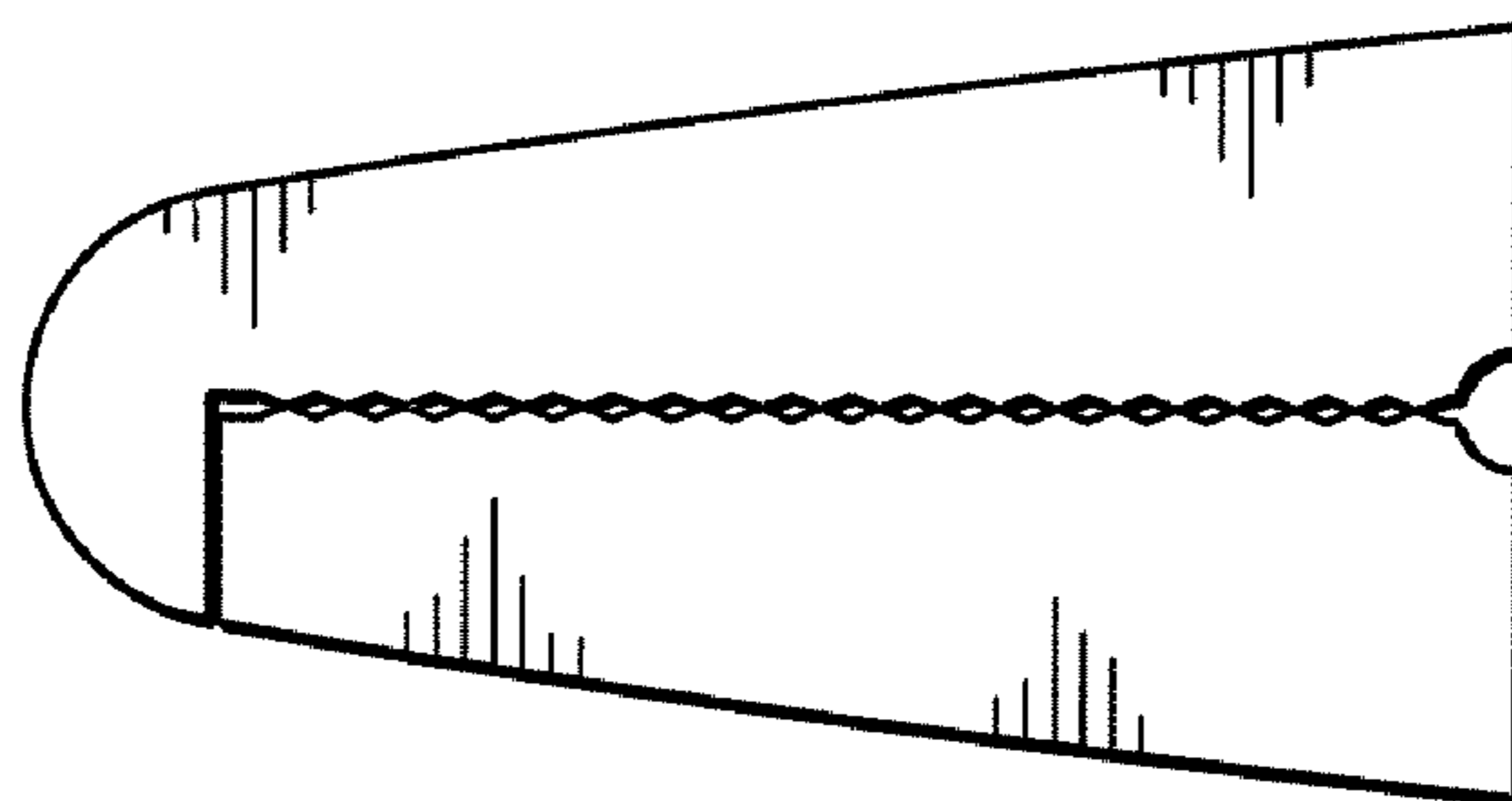

FIG. 13

