



US00D646725S

(12) **United States Design Patent**
Utsumi et al.

(10) **Patent No.:** **US D646,725 S**

(45) **Date of Patent:** **** Oct. 11, 2011**

(54) **GAME DEVICE**

(75) Inventors: **Tsubasa Utsumi**, Tokyo (JP); **Kenji Watanabe**, Tokyo (JP); **Yusuke Maekawa**, Tokyo (JP)

(73) Assignee: **Bandai Co., Ltd.**, Tokyo (JP)

(**) Term: **14 Years**

(21) Appl. No.: **29/371,115**

(22) Filed: **Oct. 27, 2010**

(30) **Foreign Application Priority Data**

May 7, 2010 (JP) 2010-011117

(51) **LOC (9) Cl.** **21-01**

(52) **U.S. Cl.** **D21/328; D21/324; D21/333; D14/496**

(58) **Field of Classification Search** D14/496, D14/401, 435, 474, 483, 217, 137, 138, 160, D14/168, 356, 203.1–203.8, 507; 345/156, 345/169, 173–179, 905; 715/727–729, 864; 710/1, 5, 8; 713/1, 600; 455/1.1, 1.7, 73, 455/344–347, 93, 95, 3.01–3.06, 550.1, 573.1; 370/342–344; 369/1, 2, 6–12; 463/43–47, 463/29–35; 273/148 B; D21/324–333; 428/1.1
See application file for complete search history.

(56) **References Cited**

U.S. PATENT DOCUMENTS

6,055,098	A *	4/2000	Lett	359/402
6,743,104	B1 *	6/2004	Ota et al.	463/44
6,934,502	B2 *	8/2005	Okuda	399/379
D522,587	S *	6/2006	Yokoi	D21/324
D546,396	S *	7/2007	Matsuno	D21/324
7,690,993	B2 *	4/2010	Totaka et al.	463/35

D615,595	S *	5/2010	Williamson et al.	D21/328
D617,846	S *	6/2010	Matsuno et al.	D21/324
D621,882	S *	8/2010	Williamson et al.	D21/328
D627,829	S *	11/2010	Williamson et al.	D21/328

* cited by examiner

Primary Examiner — Prabhakar Deshmukh

(74) *Attorney, Agent, or Firm* — Rabin & Berdo, PC

(57) **CLAIM**

The ornamental design for a game device, as shown and described.

DESCRIPTION

FIG. 1 is a front elevational view of a game device showing our new design, with the transformed portion shown in non-transformed state;

FIG. 2 is a rear elevational view thereof;

FIG. 3 is a right side elevational view thereof;

FIG. 4 is a left side elevational view thereof;

FIG. 5 is a top plan view thereof;

FIG. 6 is a bottom plan view thereof;

FIG. 7 is a top, front and left side perspective view thereof;

FIG. 8 is a top, rear and right side perspective view thereof;

FIG. 9 is a front elevational view thereof, with the game device shown in a transformed state;

FIG. 10 is a rear elevational view of FIG. 9;

FIG. 11 is a right side elevational view of FIG. 9;

FIG. 12 is a left side elevational view of FIG. 9;

FIG. 13 is a top plan view of FIG. 9;

FIG. 14 is a bottom plan view of FIG. 9;

FIG. 15 is a top, front and left side perspective view of FIG. 9; and,

FIG. 16 is a top, rear and right side perspective view of FIG. 9.

1 Claim, 16 Drawing Sheets

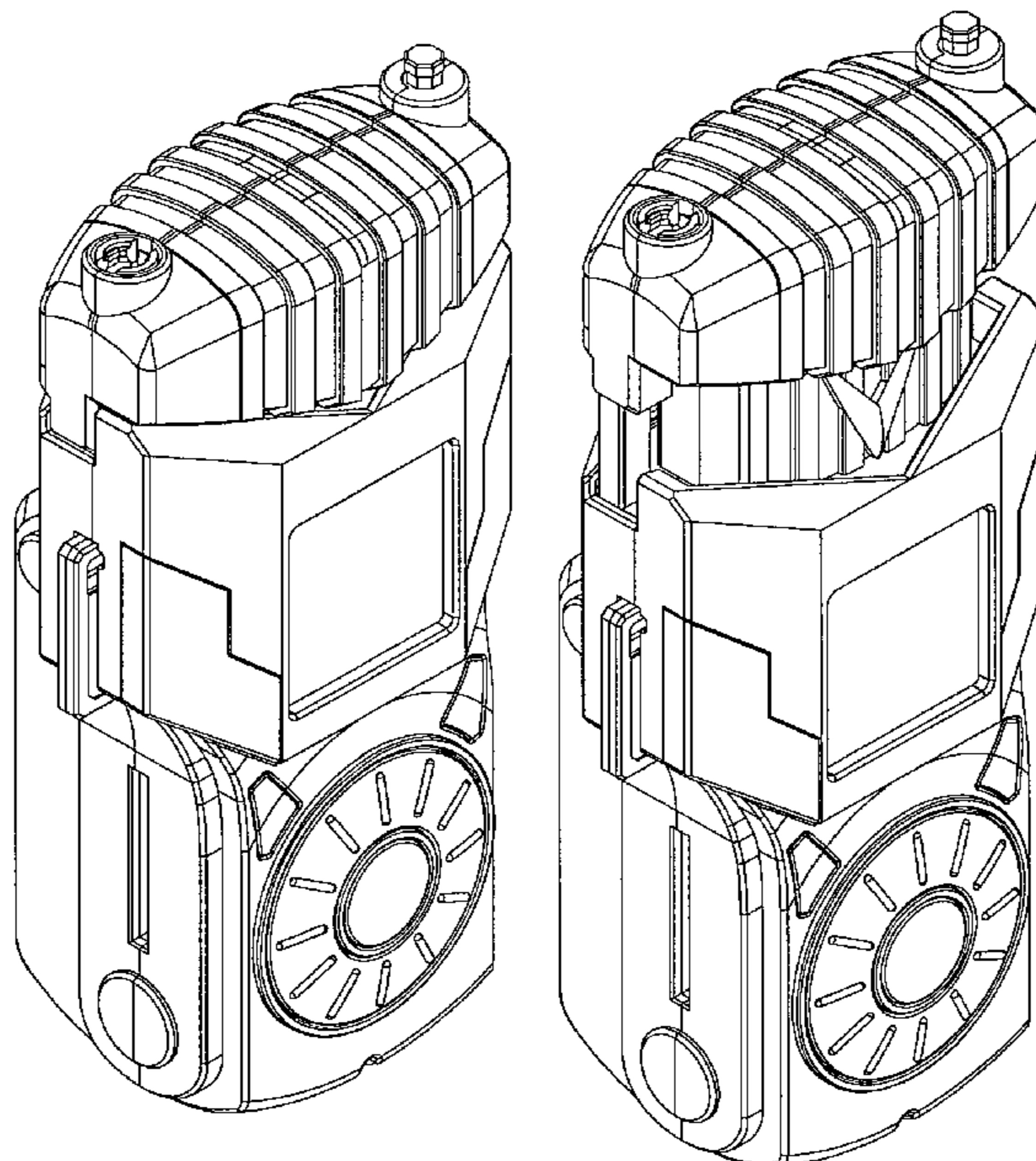

FIG. 1

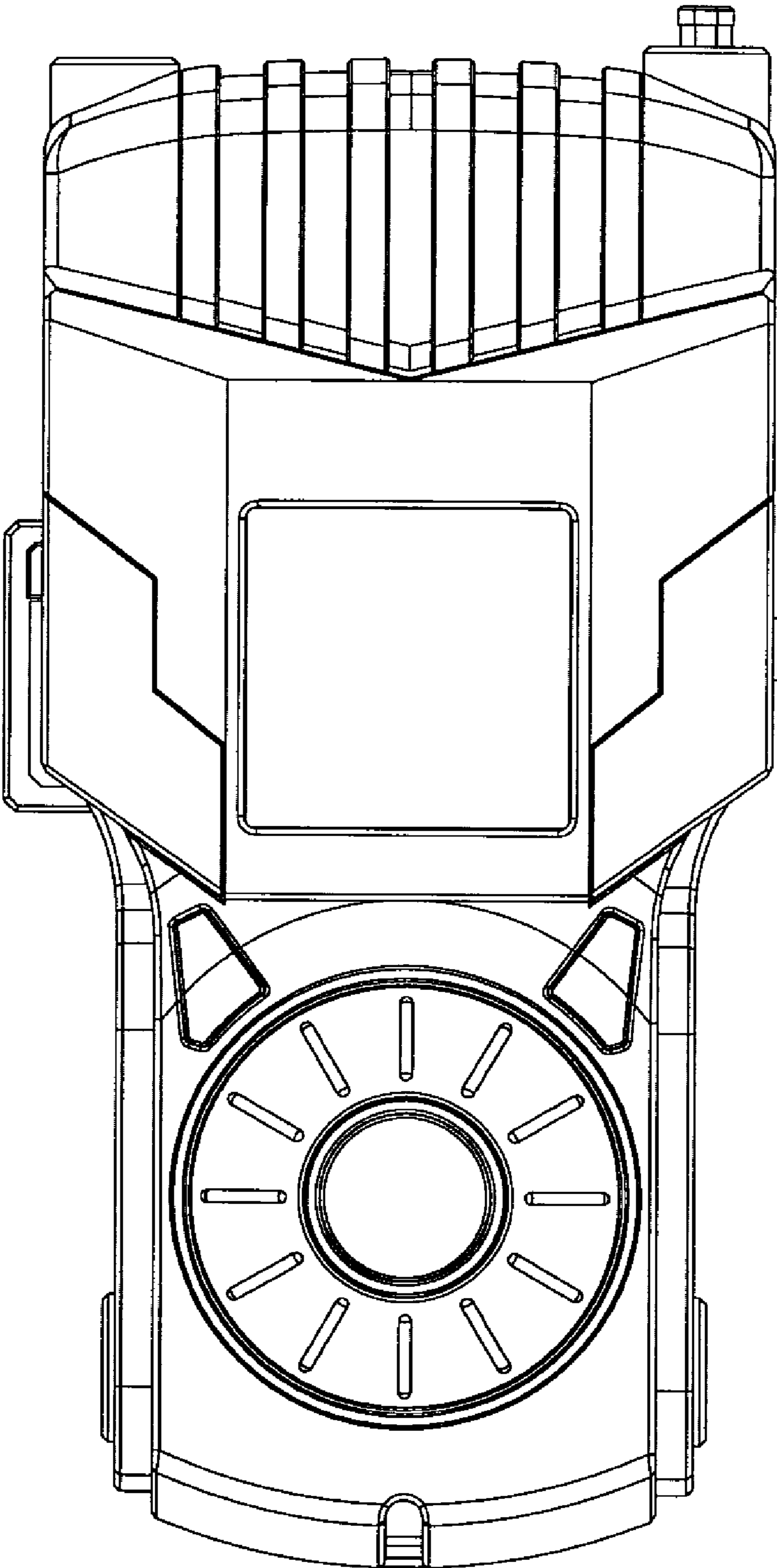

FIG. 2

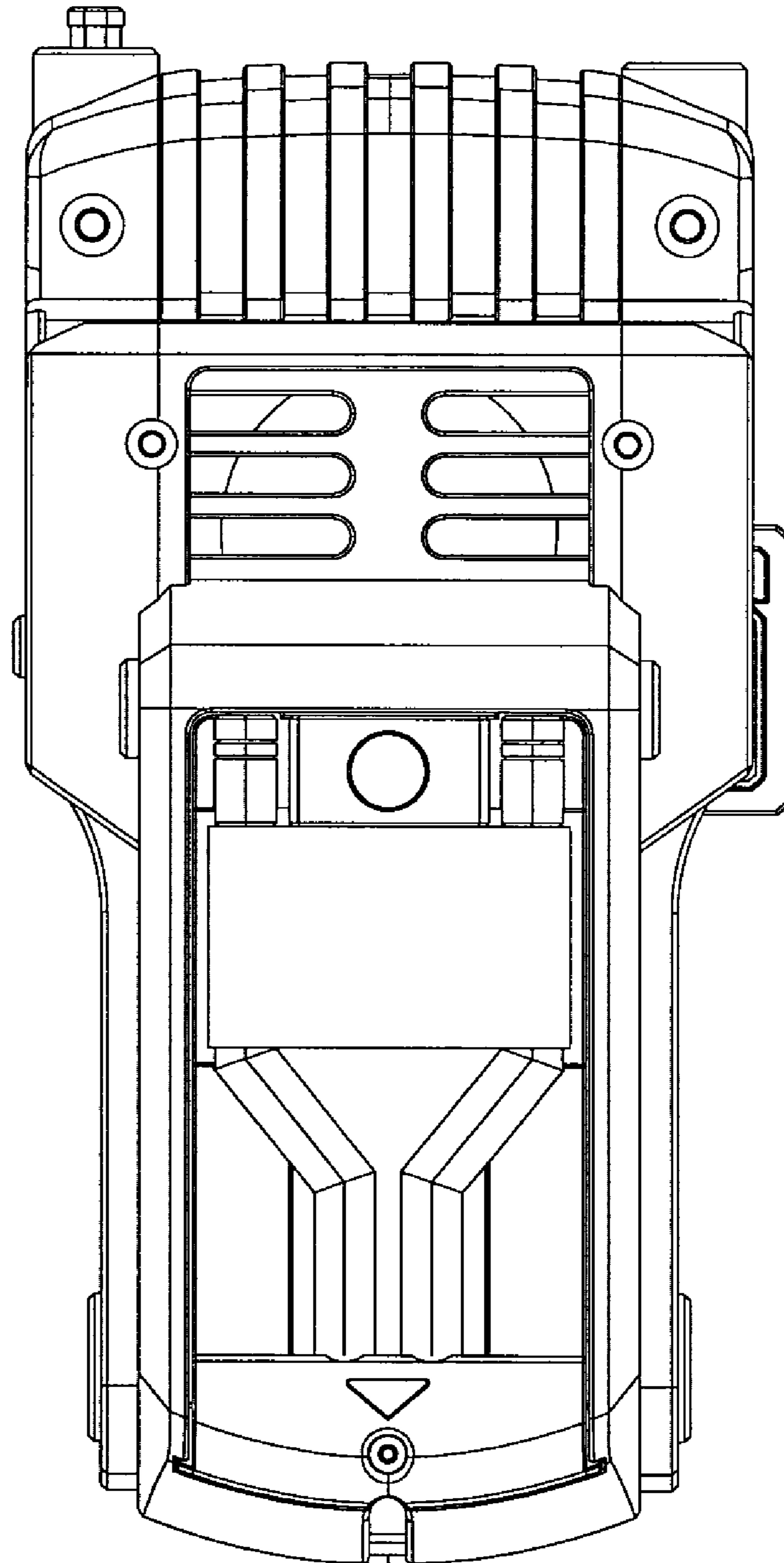

FIG. 3

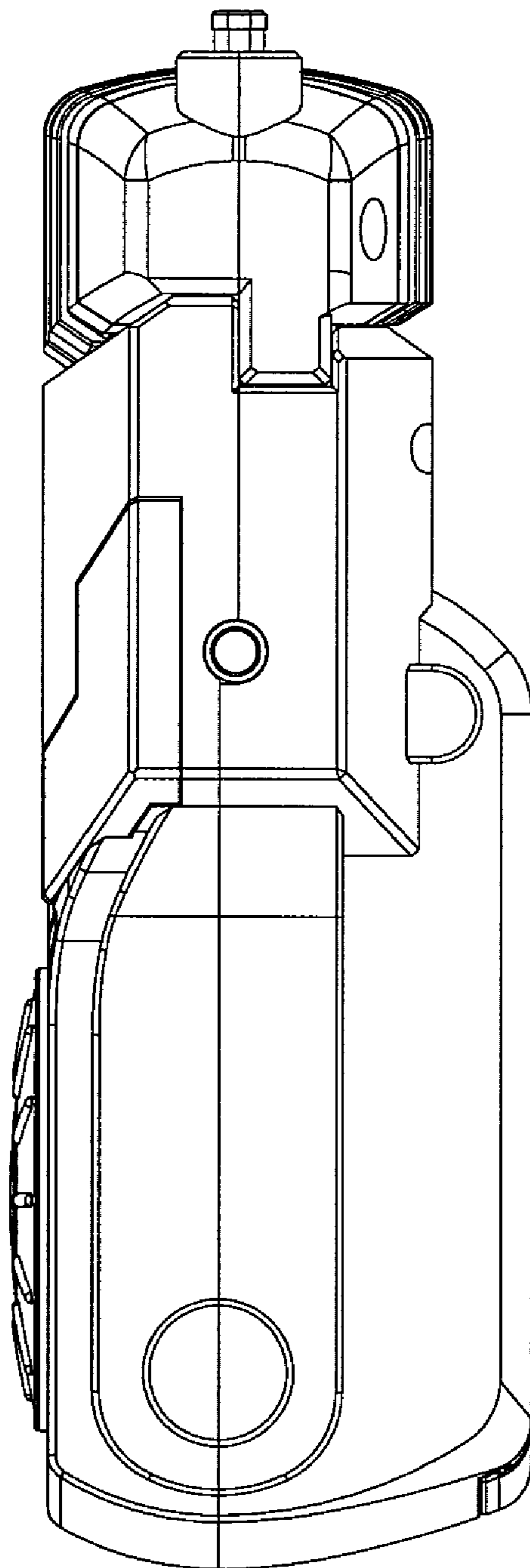

FIG. 4

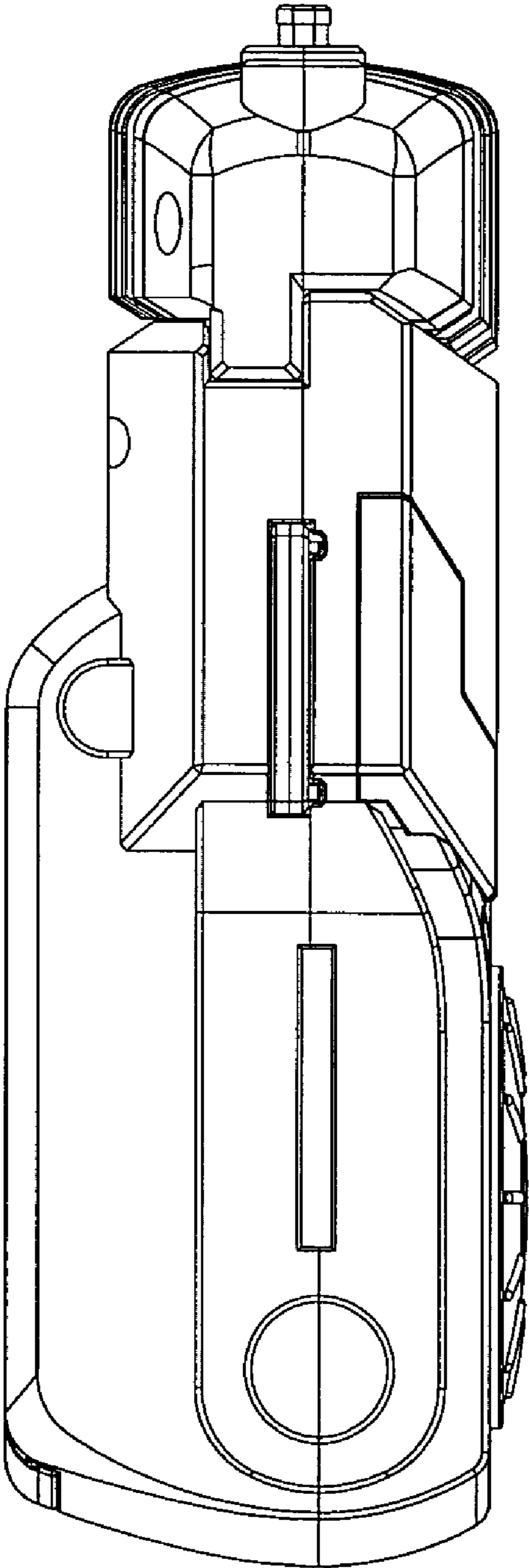

FIG. 5

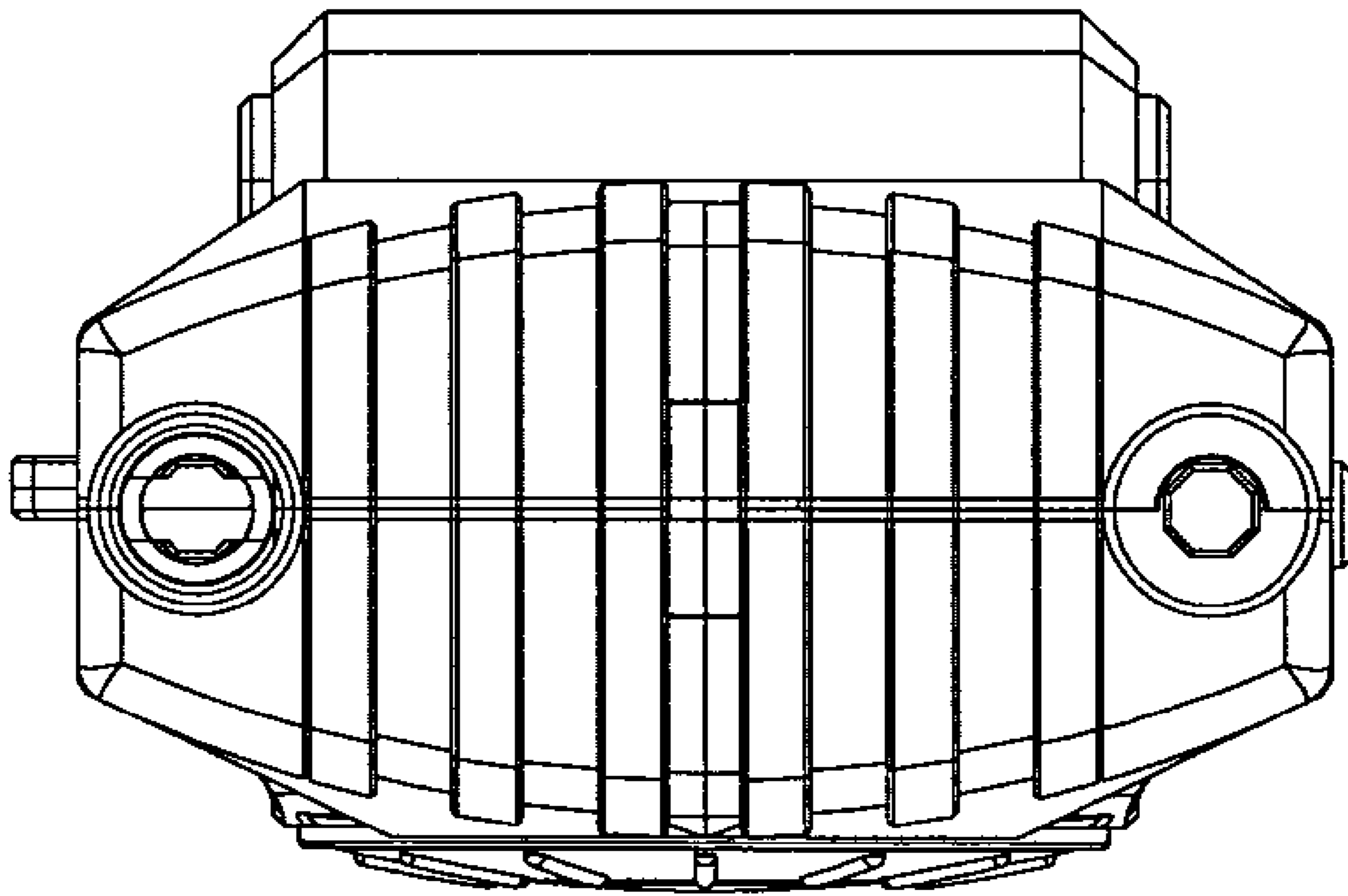

FIG. 6

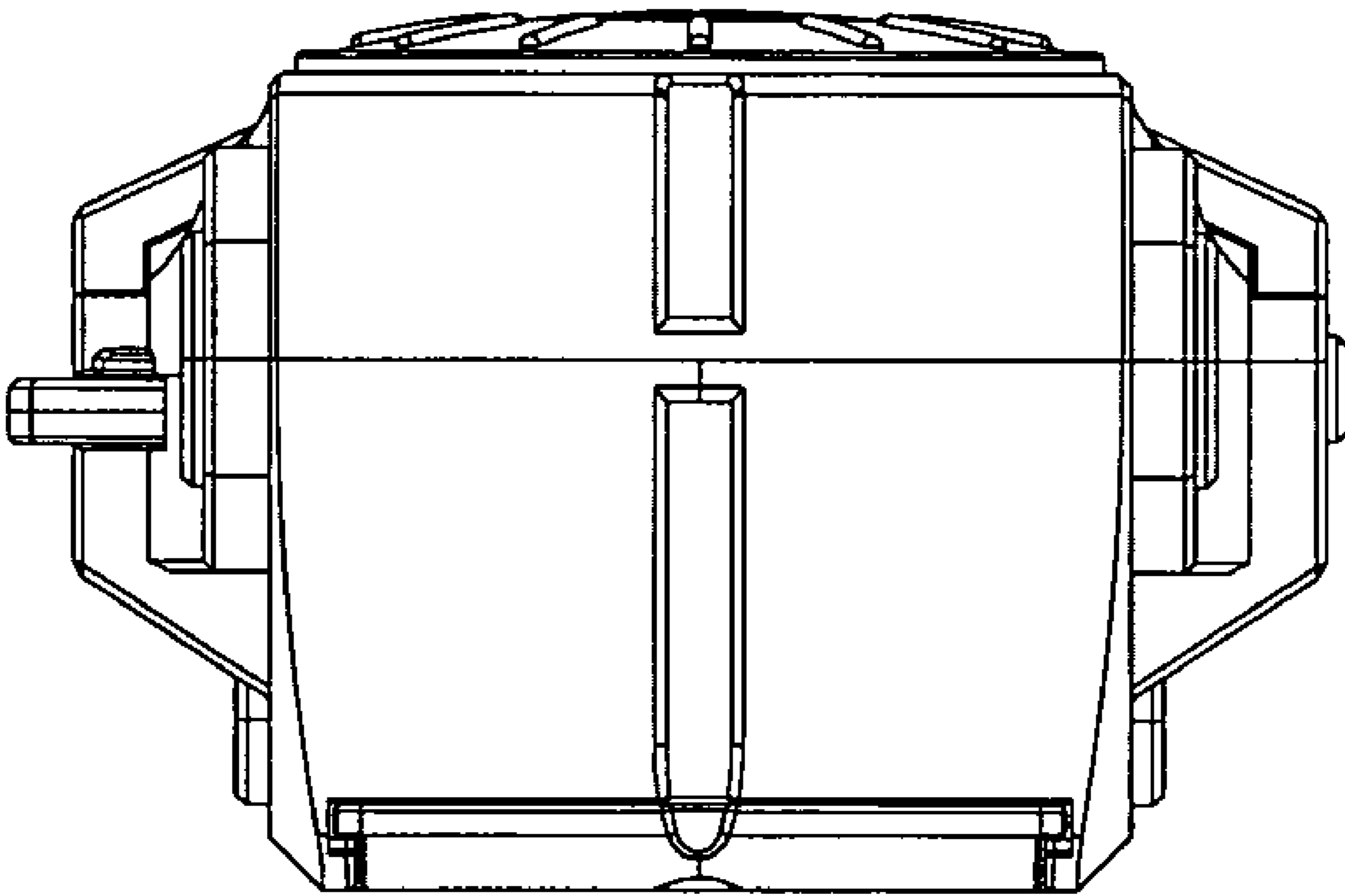

FIG. 7

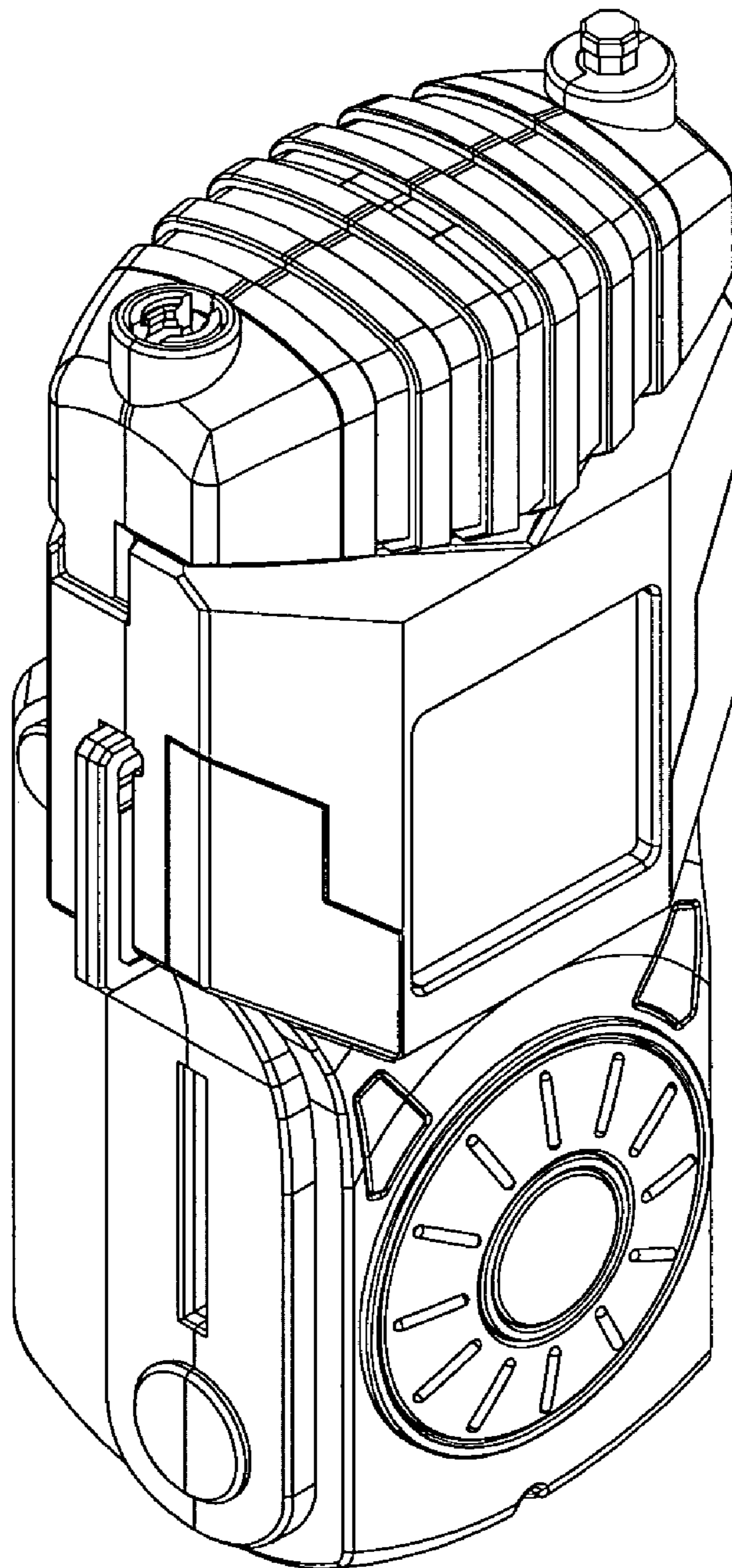

FIG. 8

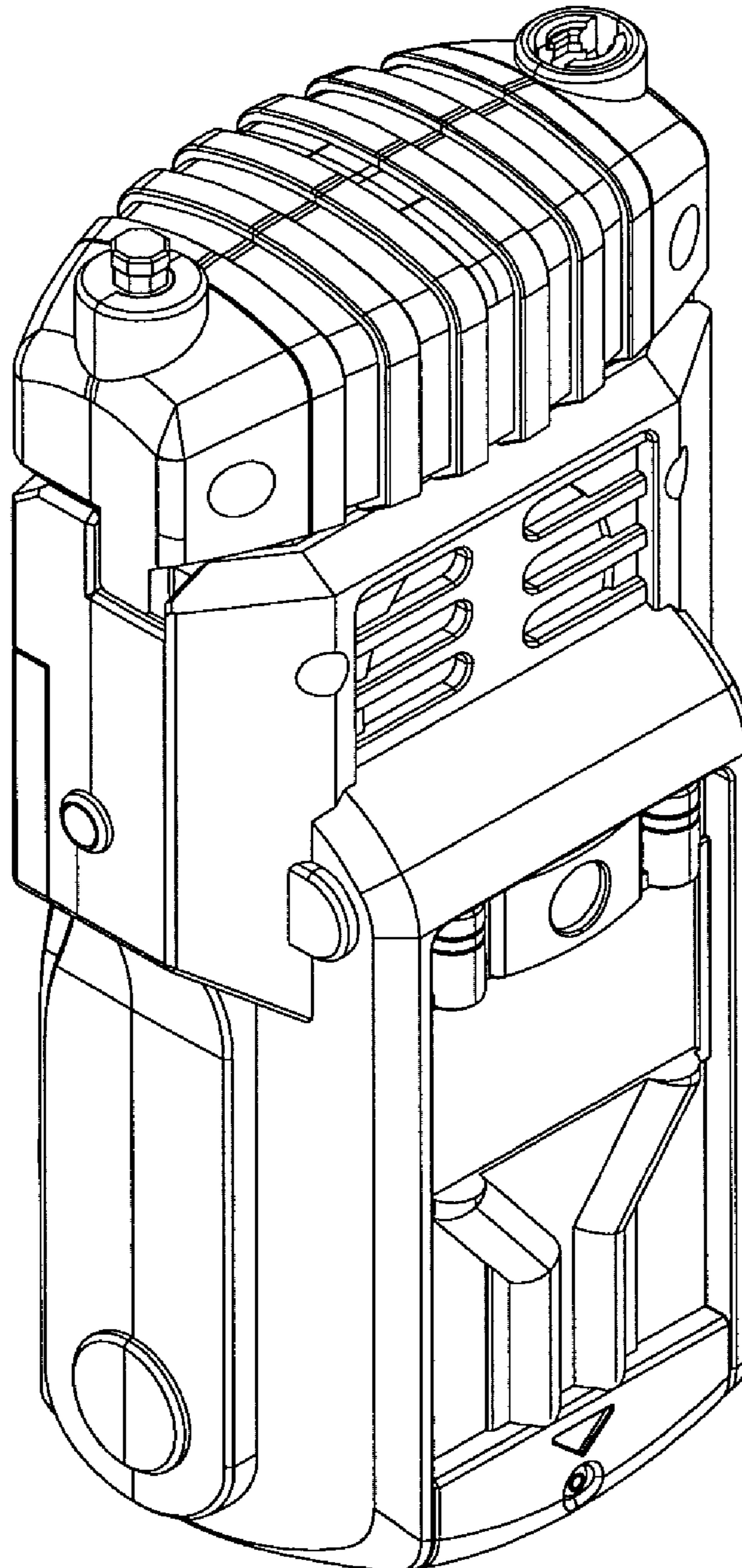

FIG. 9

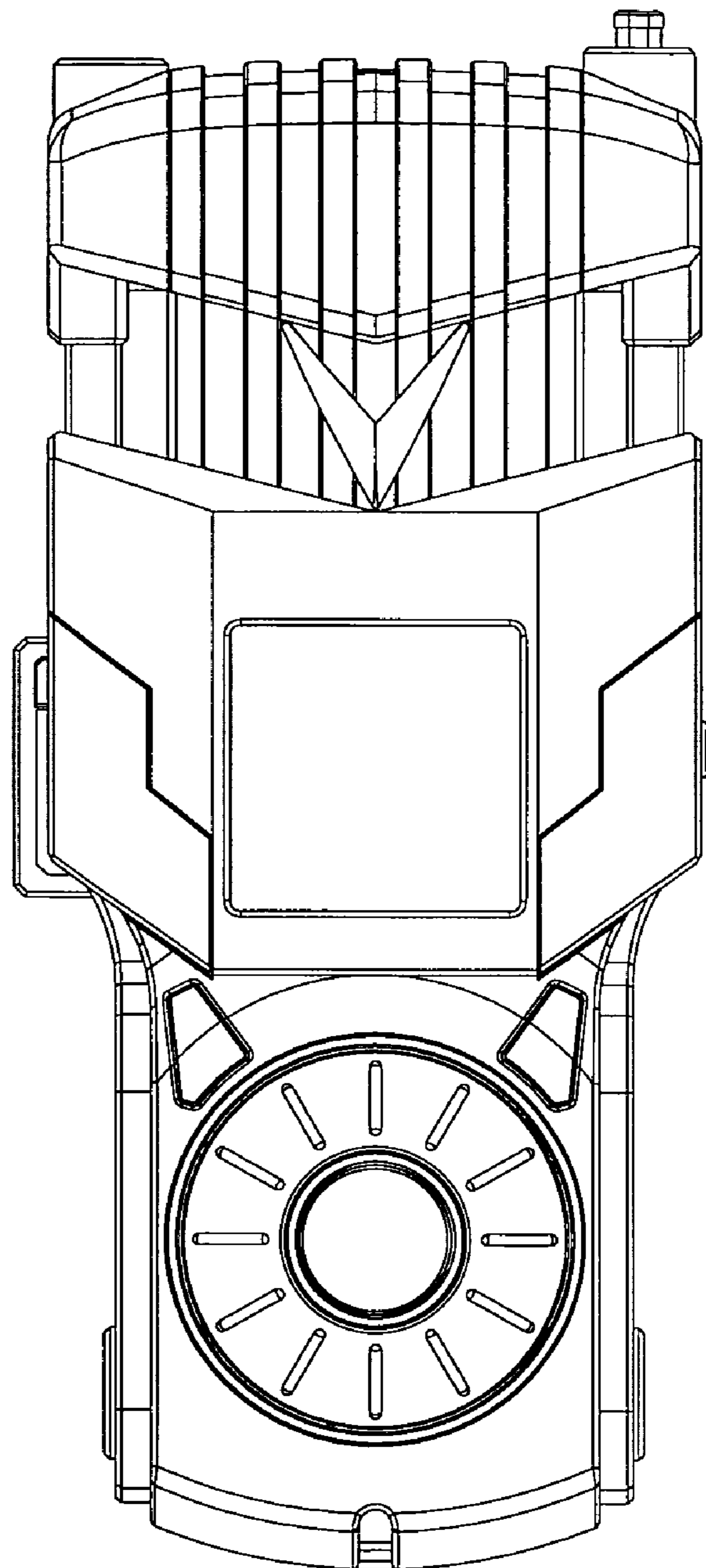

FIG. 10

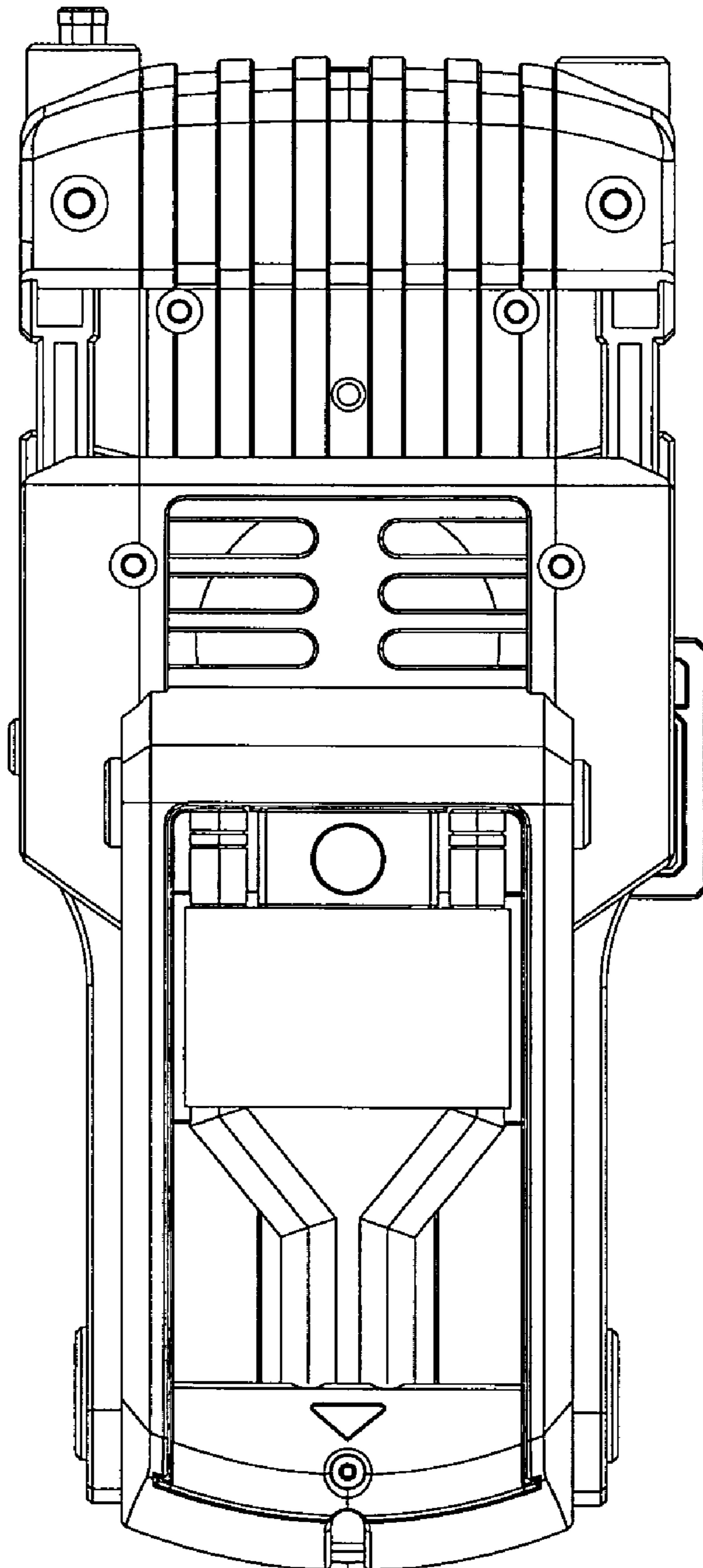

FIG. 11

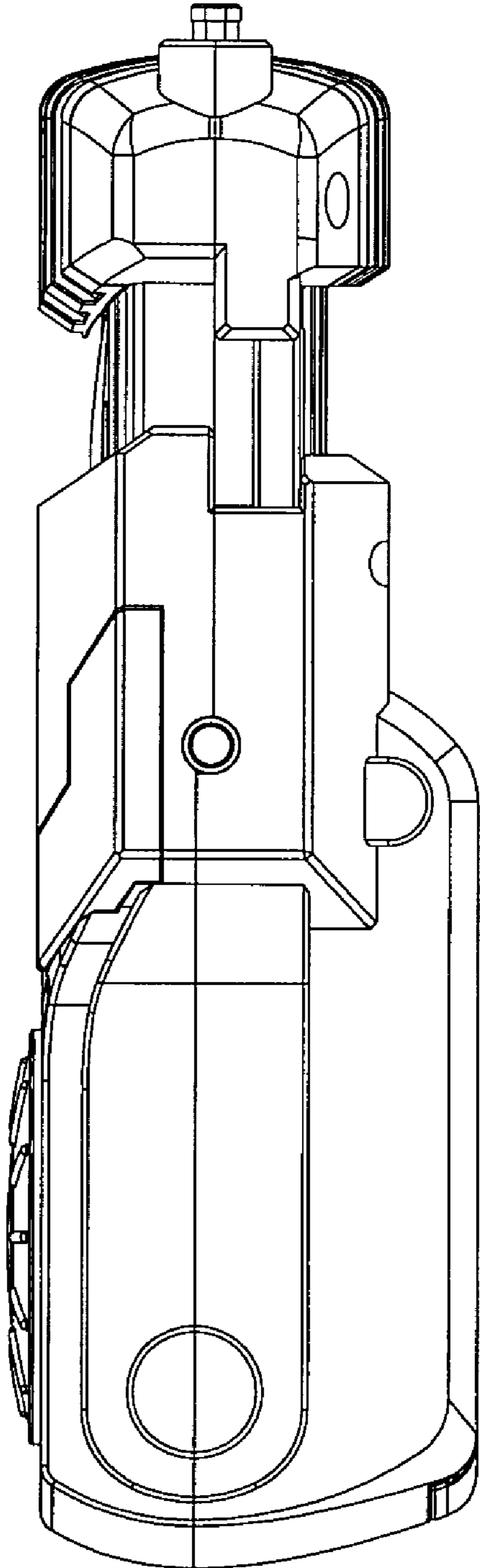

FIG. 12

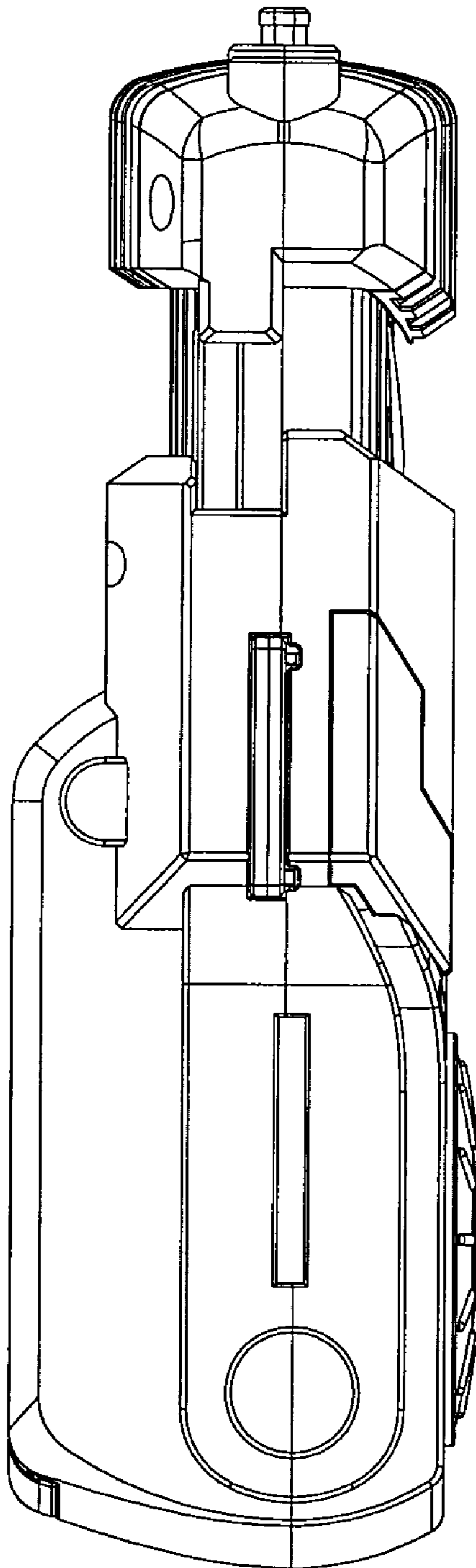

FIG. 13

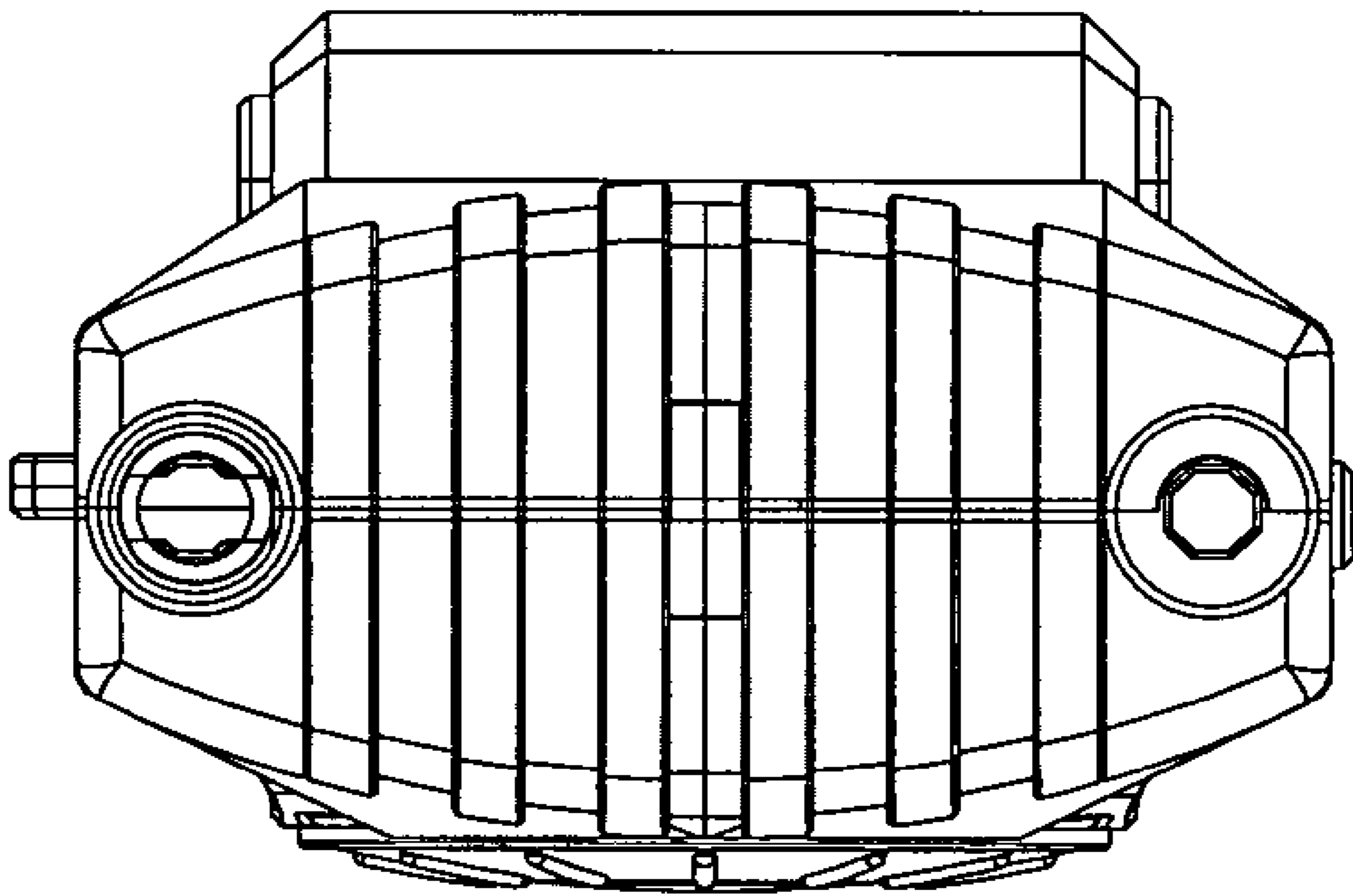

FIG. 14

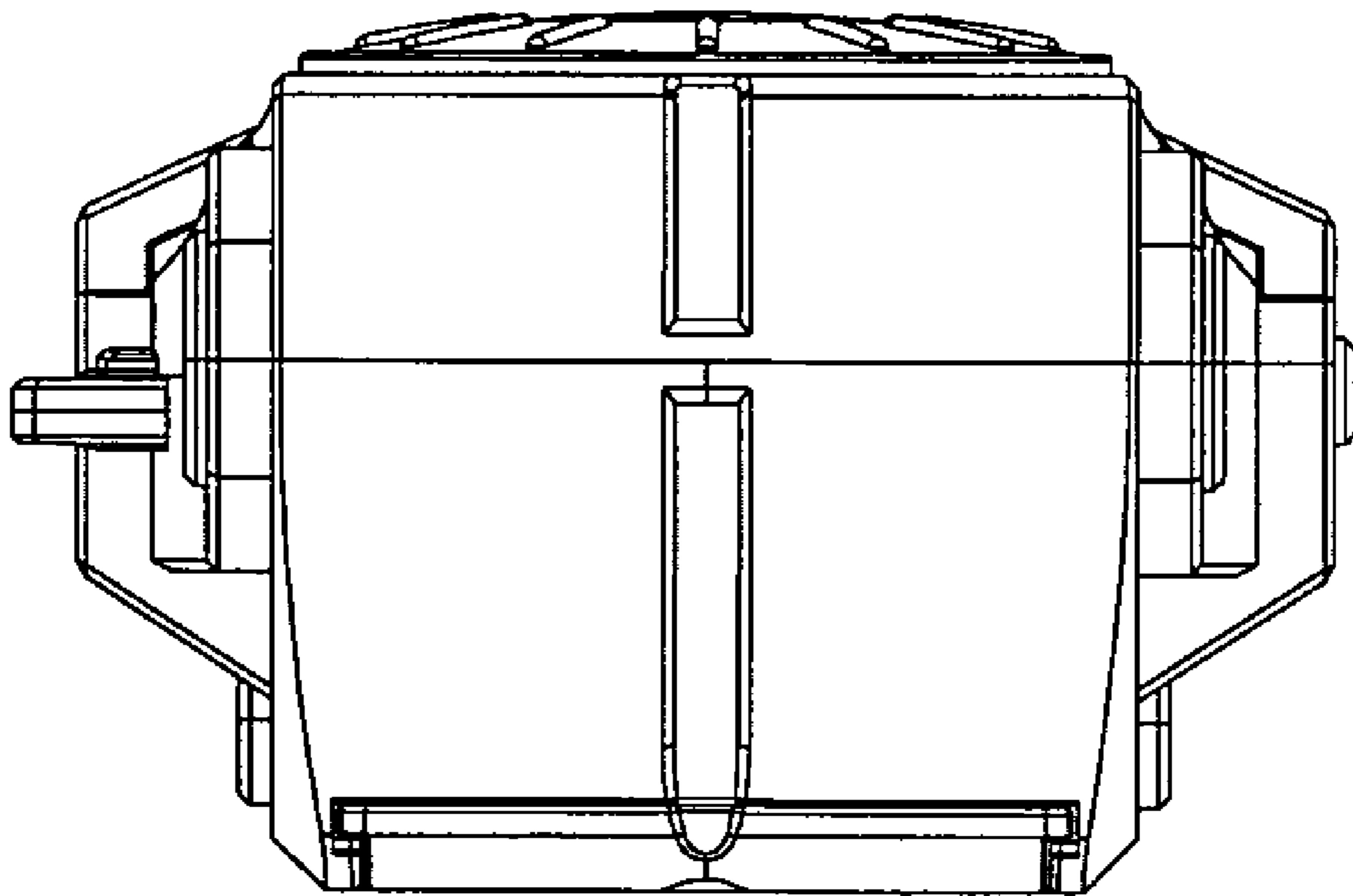

FIG. 15

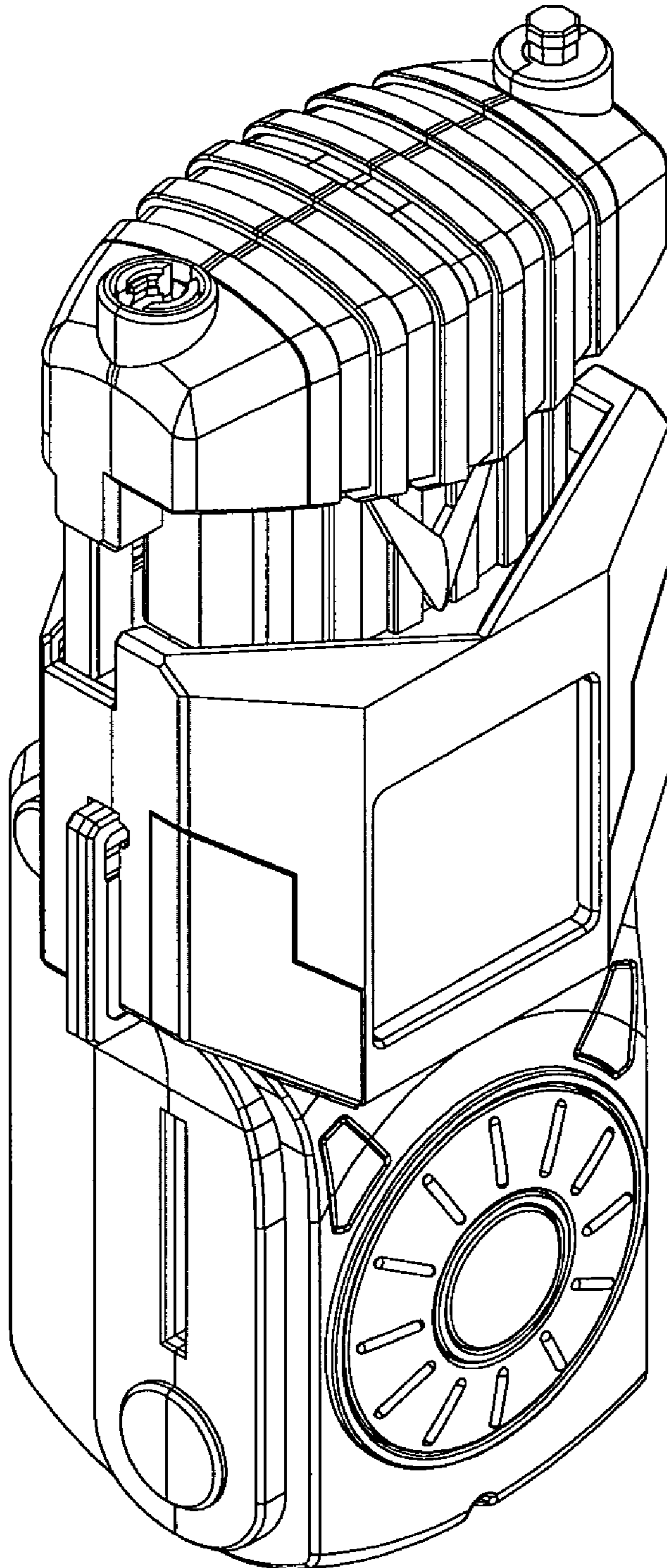

FIG. 16

