



US00D646703S

(12) **United States Design Patent**  
**Wong**

(10) **Patent No.:** **US D646,703 S**

(45) **Date of Patent:** **\*\* \*Oct. 11, 2011**

(54) **DUAL ARM ROBOT**

(75) Inventor: **Kenny Wong**, Hagersten (SE)

(73) Assignee: **ABB Research Ltd.** (CH)

(\*\*) Term: **14 Years**

(21) Appl. No.: **29/378,220**

(22) Filed: **Nov. 1, 2010**

(30) **Foreign Application Priority Data**

Apr. 30, 2010 (EM) ..... 001702986-0003

(51) **LOC (9) Cl.** ..... **15-99**

(52) **U.S. Cl.** ..... **D15/199**

(58) **Field of Classification Search** ..... D15/122,  
D15/199; D24/176; 74/490.01, 490.02,  
74/490.03, 490.05; 219/124.34, 639; 318/560;  
700/99, 150

See application file for complete search history.

(56) **References Cited**

**U.S. PATENT DOCUMENTS**

D292,604 S *	11/1987	Seo	.....	D21/578
D298,766 S *	11/1988	Tanno et al.	.....	D21/578
D456,080 S *	4/2002	Karlsson	.....	D24/185
D461,484 S *	8/2002	Kraft	.....	D15/199
D548,759 S *	8/2007	Kraft	.....	D15/199
D572,739 S *	7/2008	Jennings et al.	.....	D15/199
D598,961 S *	8/2009	Pasko et al.	.....	D21/533

\* cited by examiner

*Primary Examiner* — Patricia Palasik

(74) *Attorney, Agent, or Firm* — St. Onge Steward Johnston & Reens LLC

(57) **CLAIM**

The ornamental design for a dual arm robot, as shown and described.

**DESCRIPTION**

FIG. 1 is a rear isometric view of a dual arm robot in accordance with the new design;  
 FIG. 2 is a front isometric view thereof;  
 FIG. 3 is a left side view thereof;  
 FIG. 4 is a right side view thereof;  
 FIG. 5 is a top isometric view thereof;  
 FIG. 6 is a left side perspective view thereof;  
 FIG. 7 is an enlarged rear elevation view of an end section of the arm of the dual arm robot of FIG. 1 in an alternate condition of use, with other parts of the dual arm robot omitted for clarity of disclosure;  
 FIG. 8 is a front elevation view thereof;  
 FIG. 9 is a left side elevation view thereof;  
 FIG. 10 is a right side elevation view thereof;  
 FIG. 11 is a top plan view thereof; and  
 FIG. 12 is a left side perspective view thereof;  
 FIG. 13 is an enlarged rear elevation view of an end section of the arm of the dual arm robot of FIG. 1 in an alternate condition of use, with other parts of the dual arm robot omitted for clarity of disclosure;  
 FIG. 14 is front elevation view thereof;  
 FIG. 15 is a left side elevation view thereof;  
 FIG. 16 is a right side elevation view thereof;  
 FIG. 17 is a top plan view thereof; and,  
 FIG. 18 is a left side perspective view thereof.

**1 Claim, 18 Drawing Sheets**

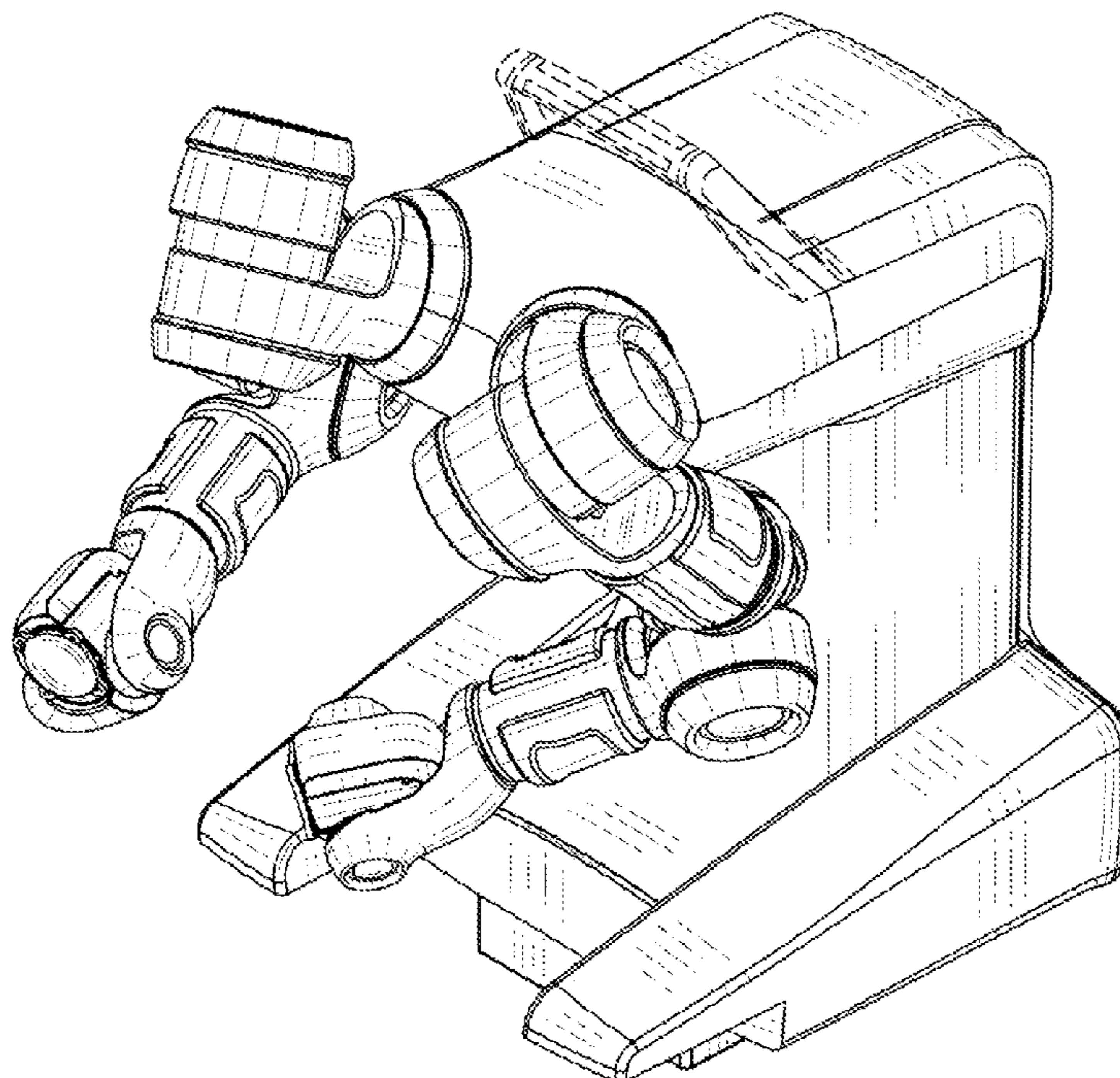

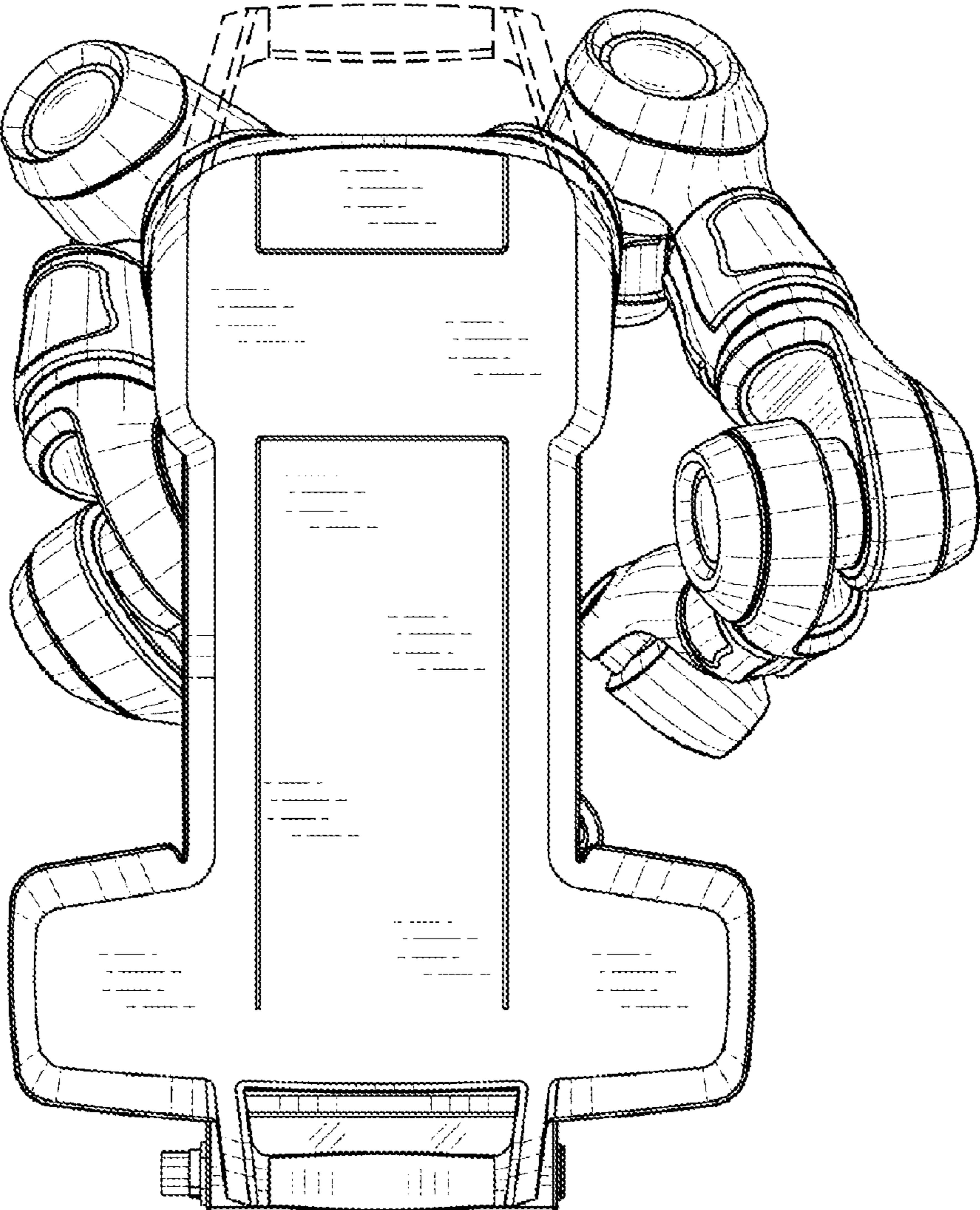

FIG. 1



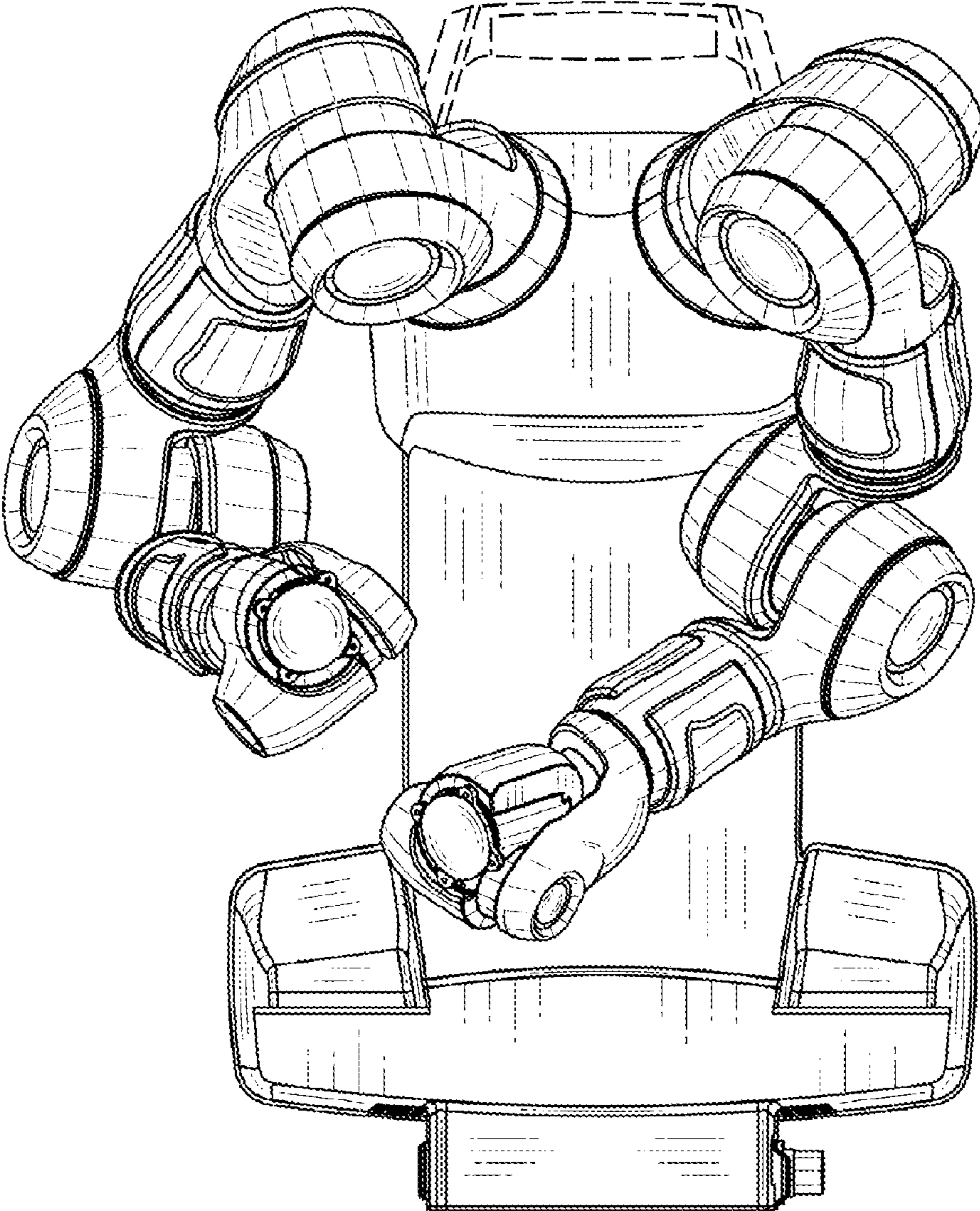

FIG. 2

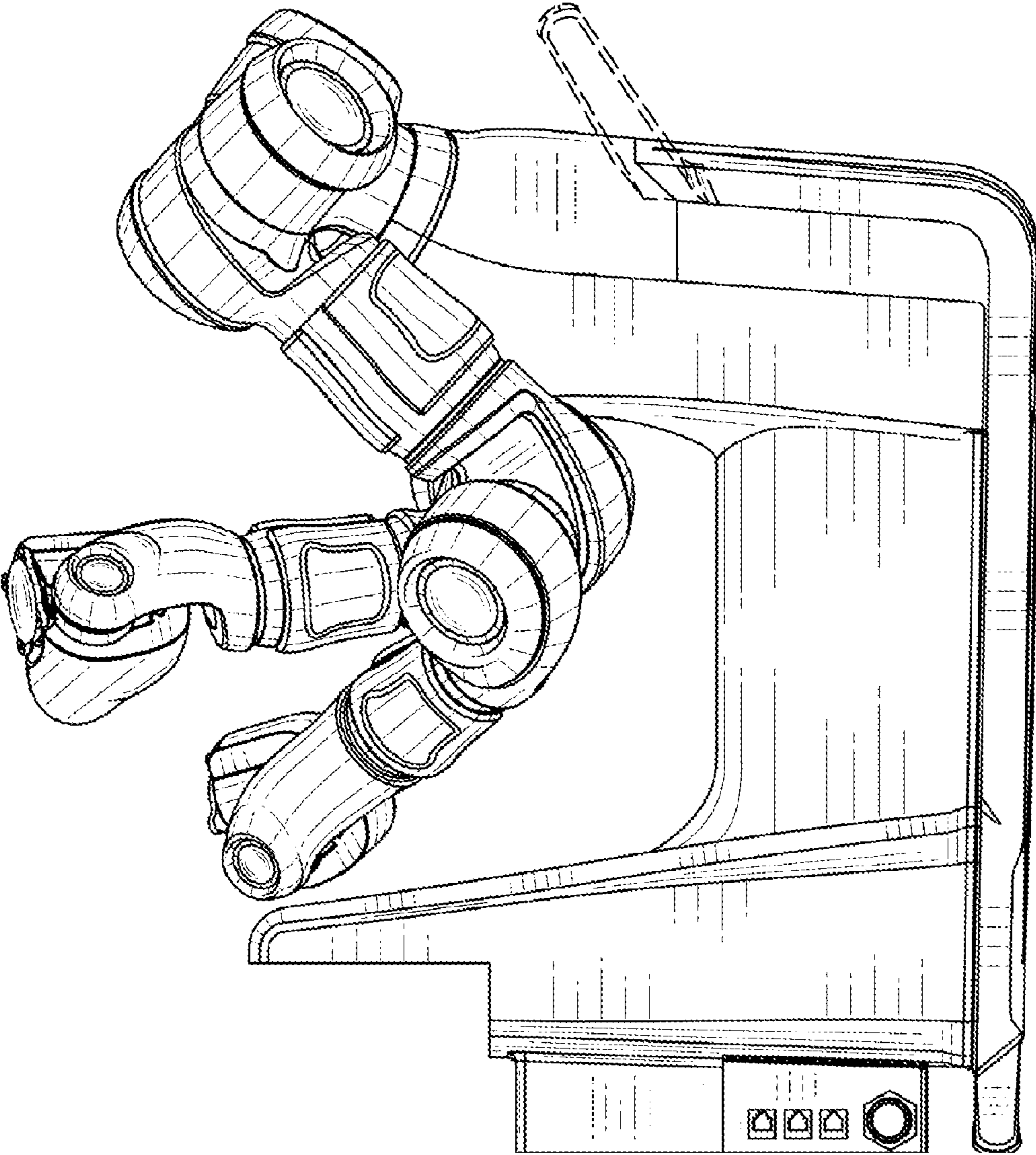

FIG. 3

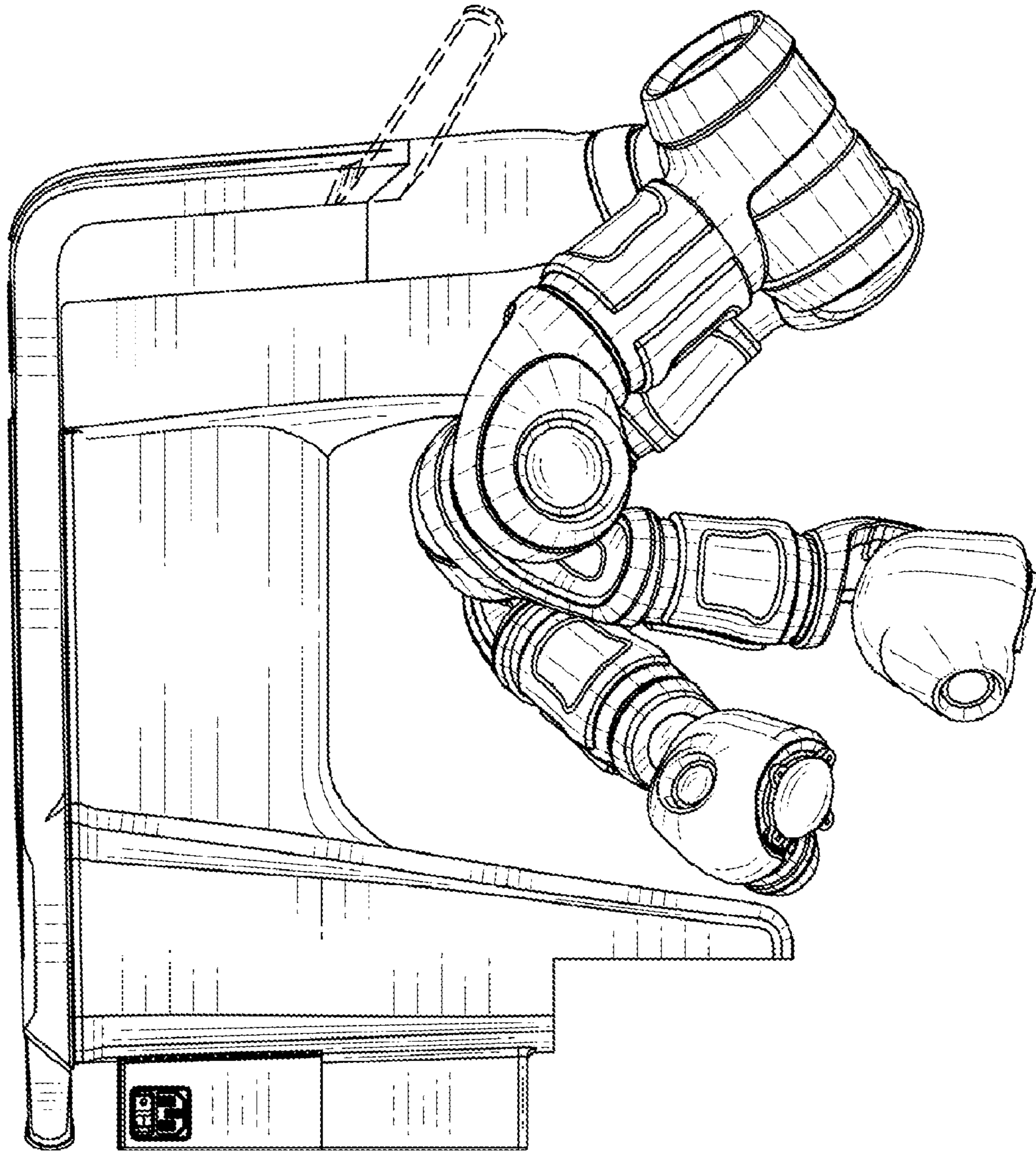

FIG. 4



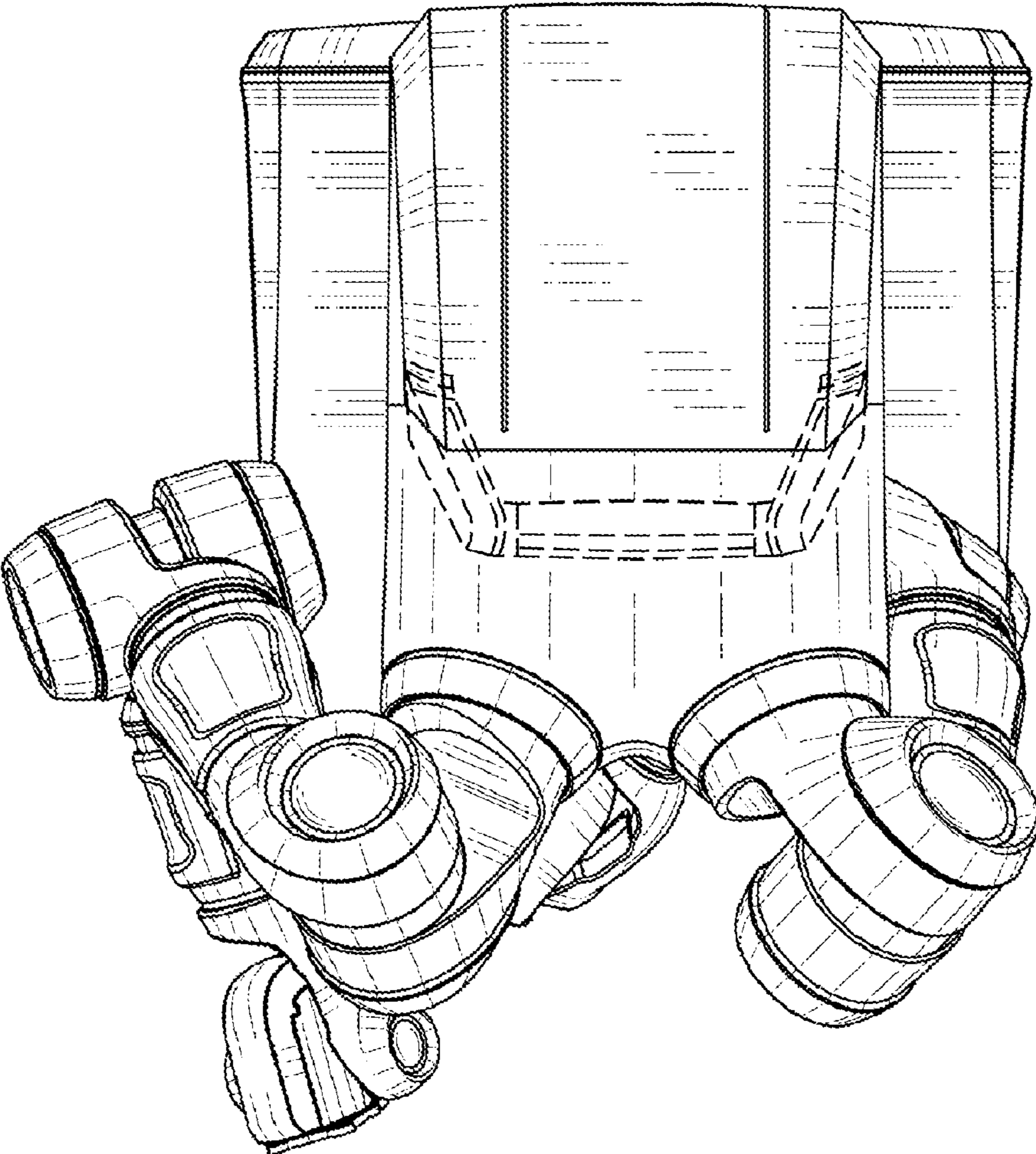

FIG. 5

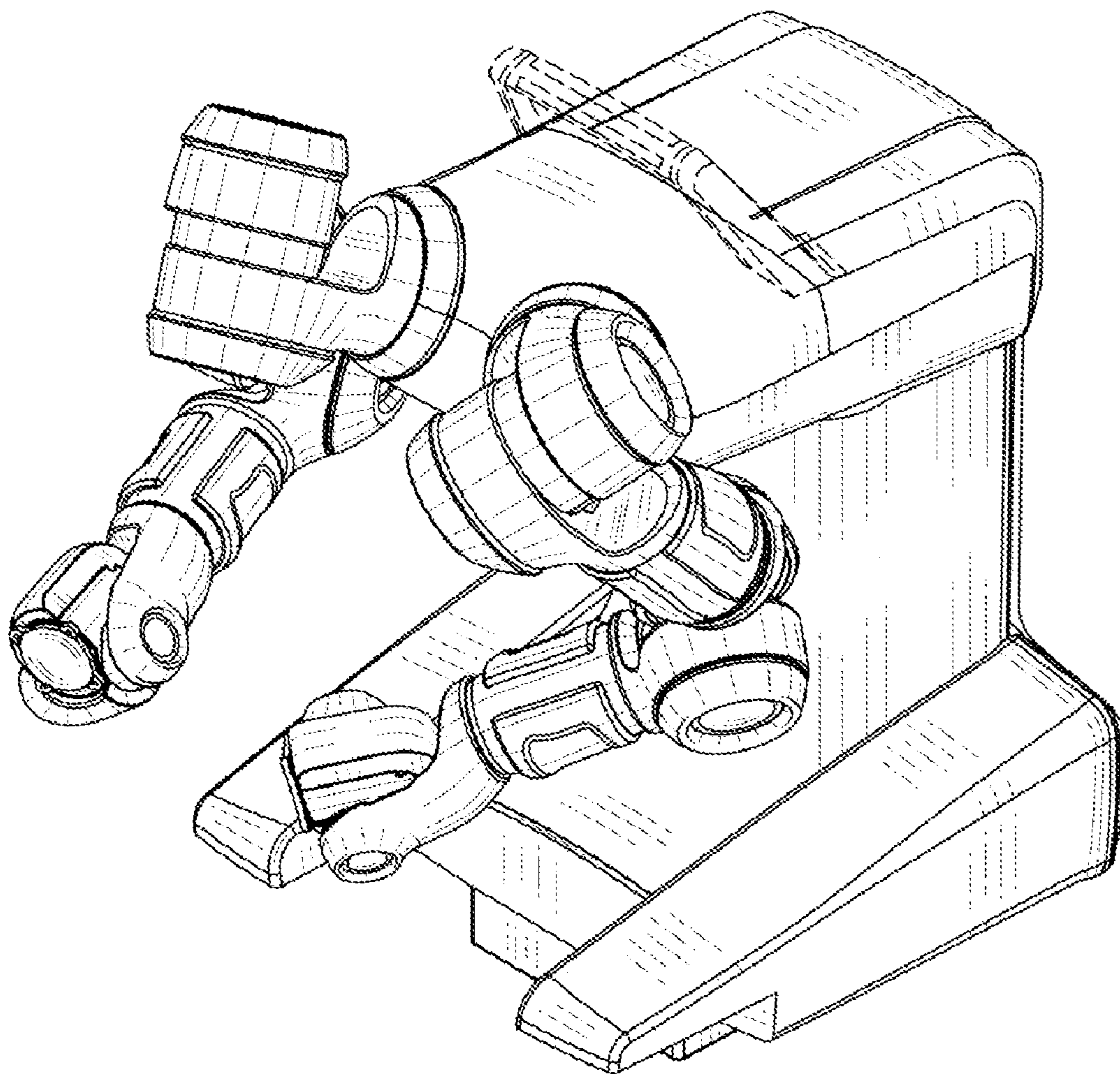

FIG. 6

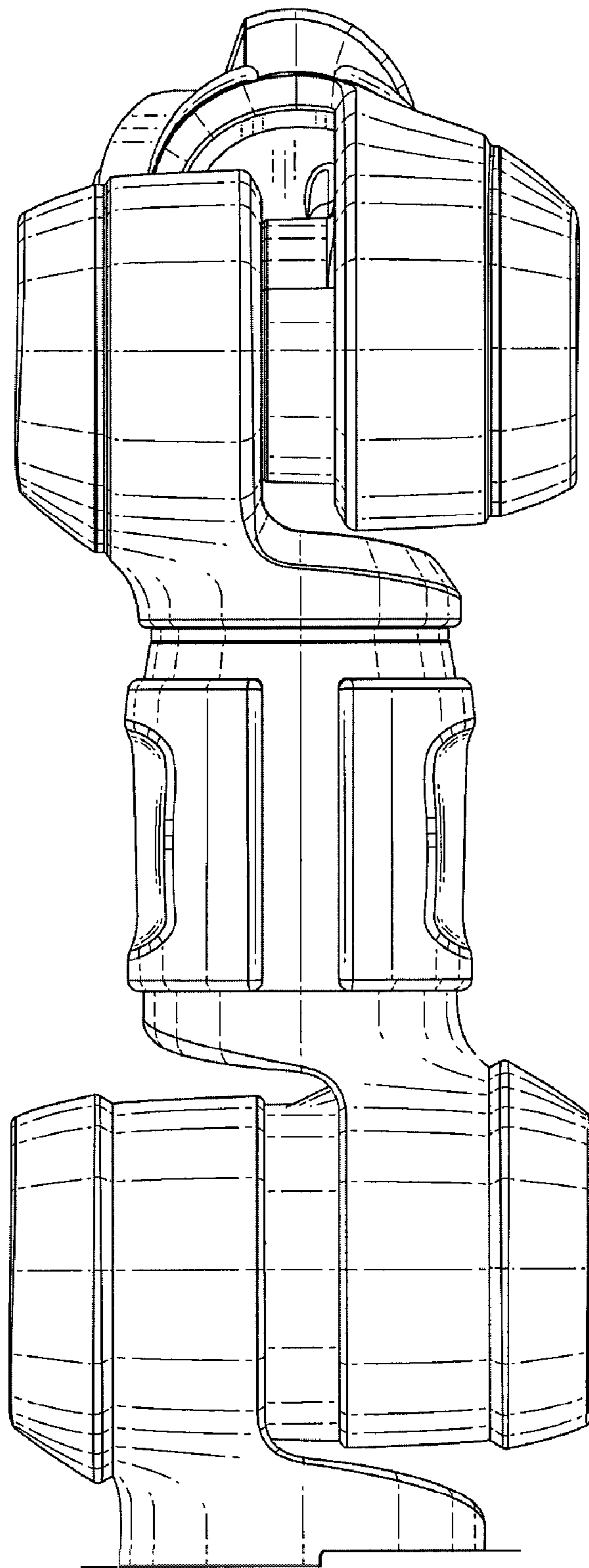

FIG. 7



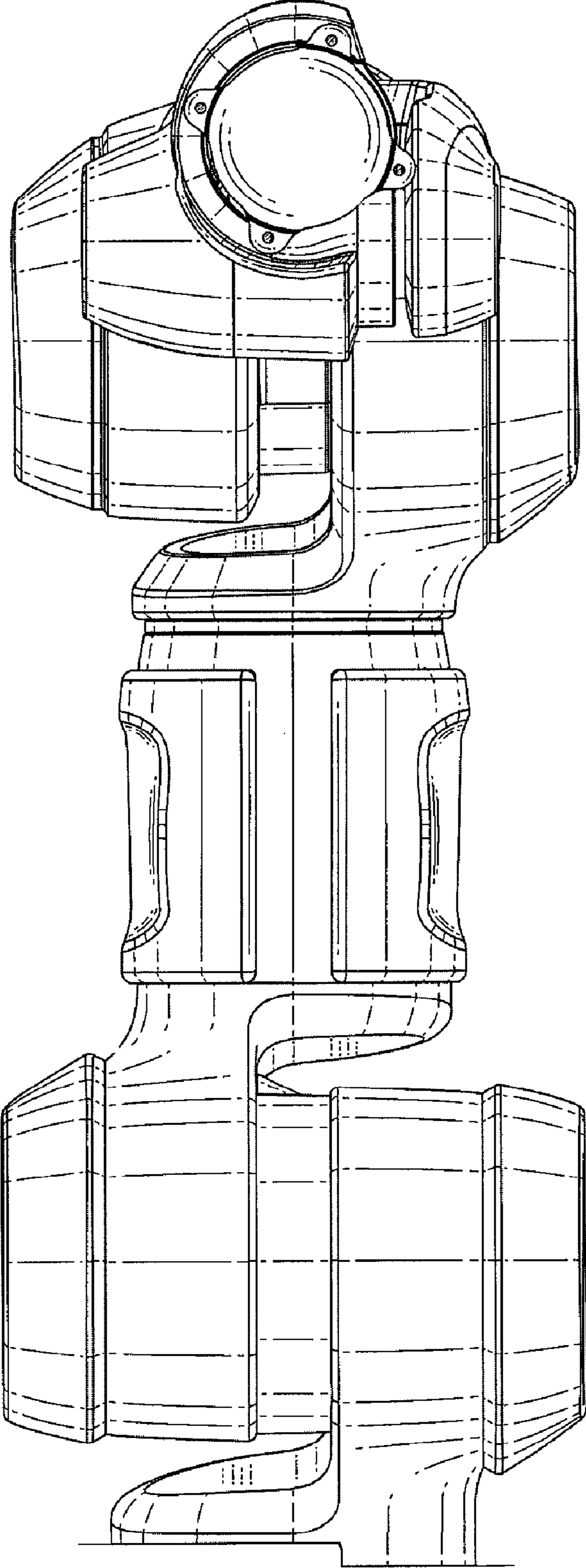

FIG. 8

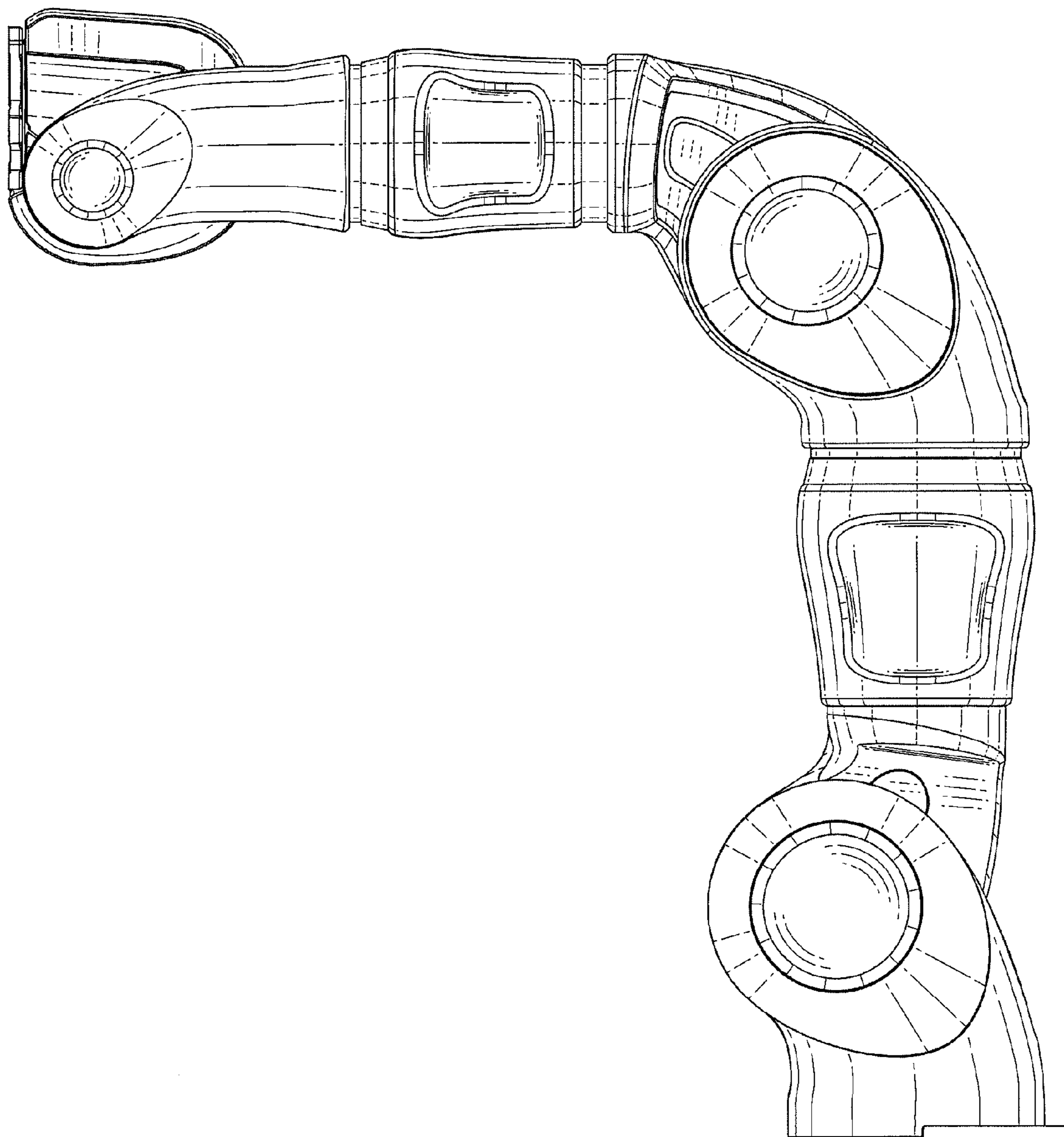

FIG. 9

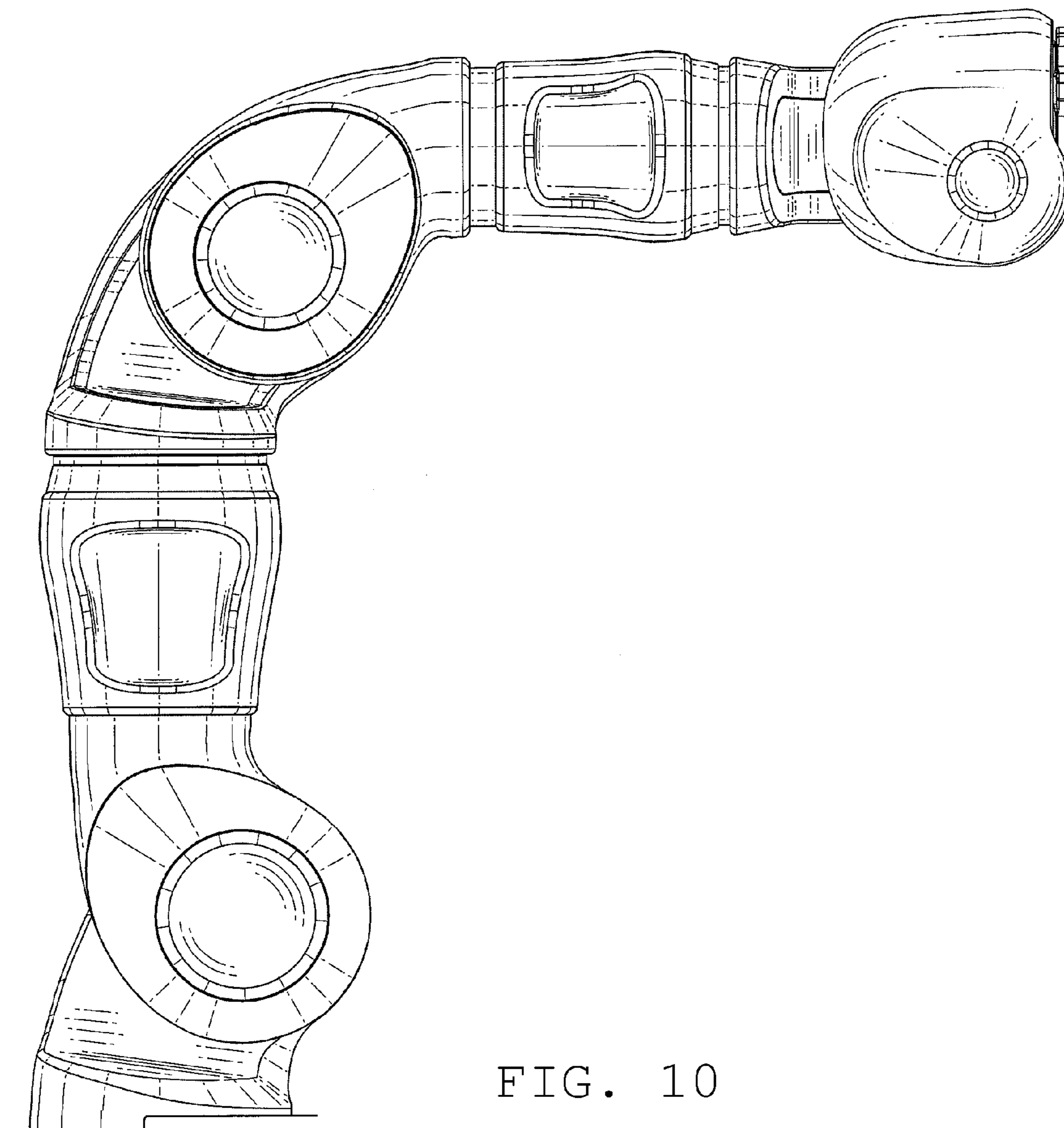

FIG. 10



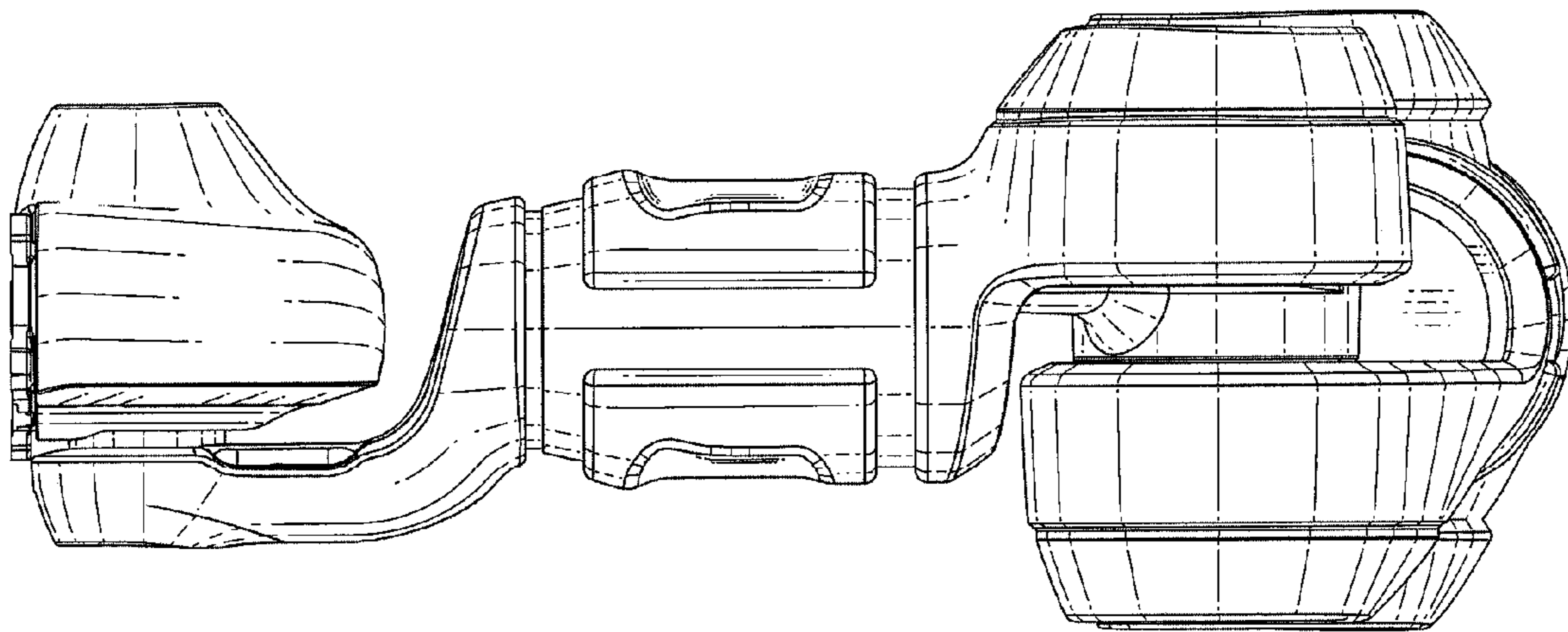

FIG. 11

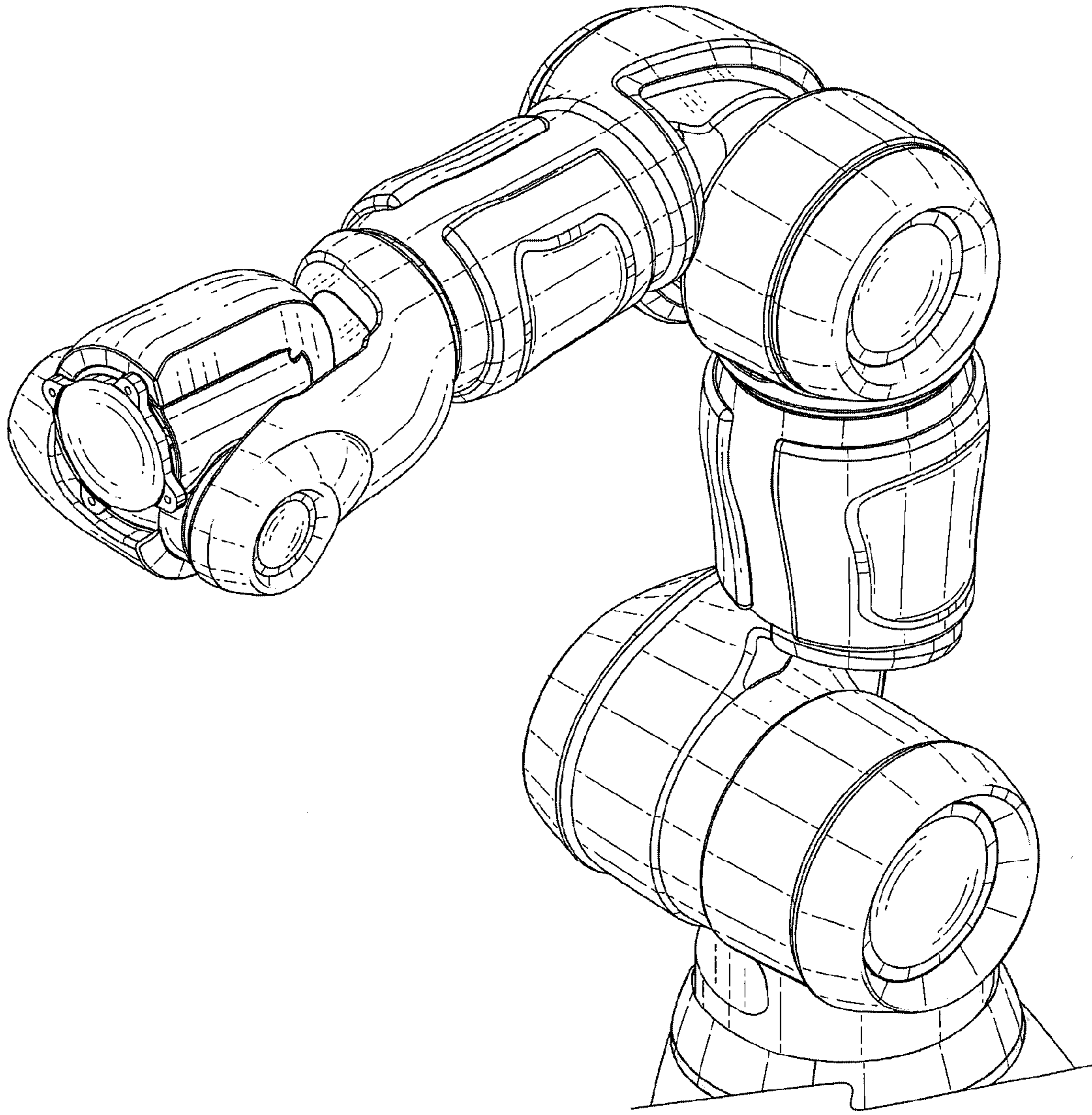

FIG. 12

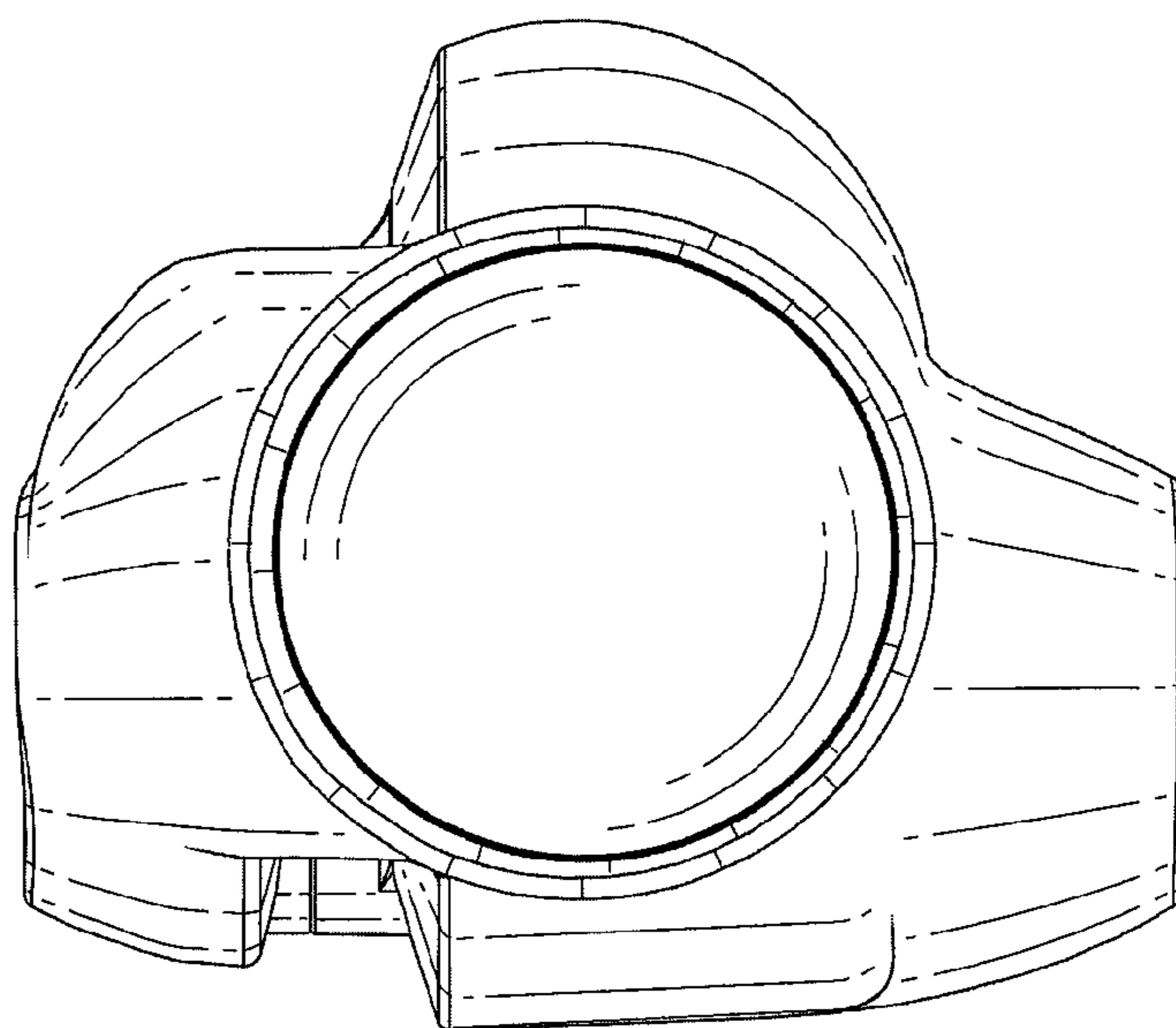

FIG. 13



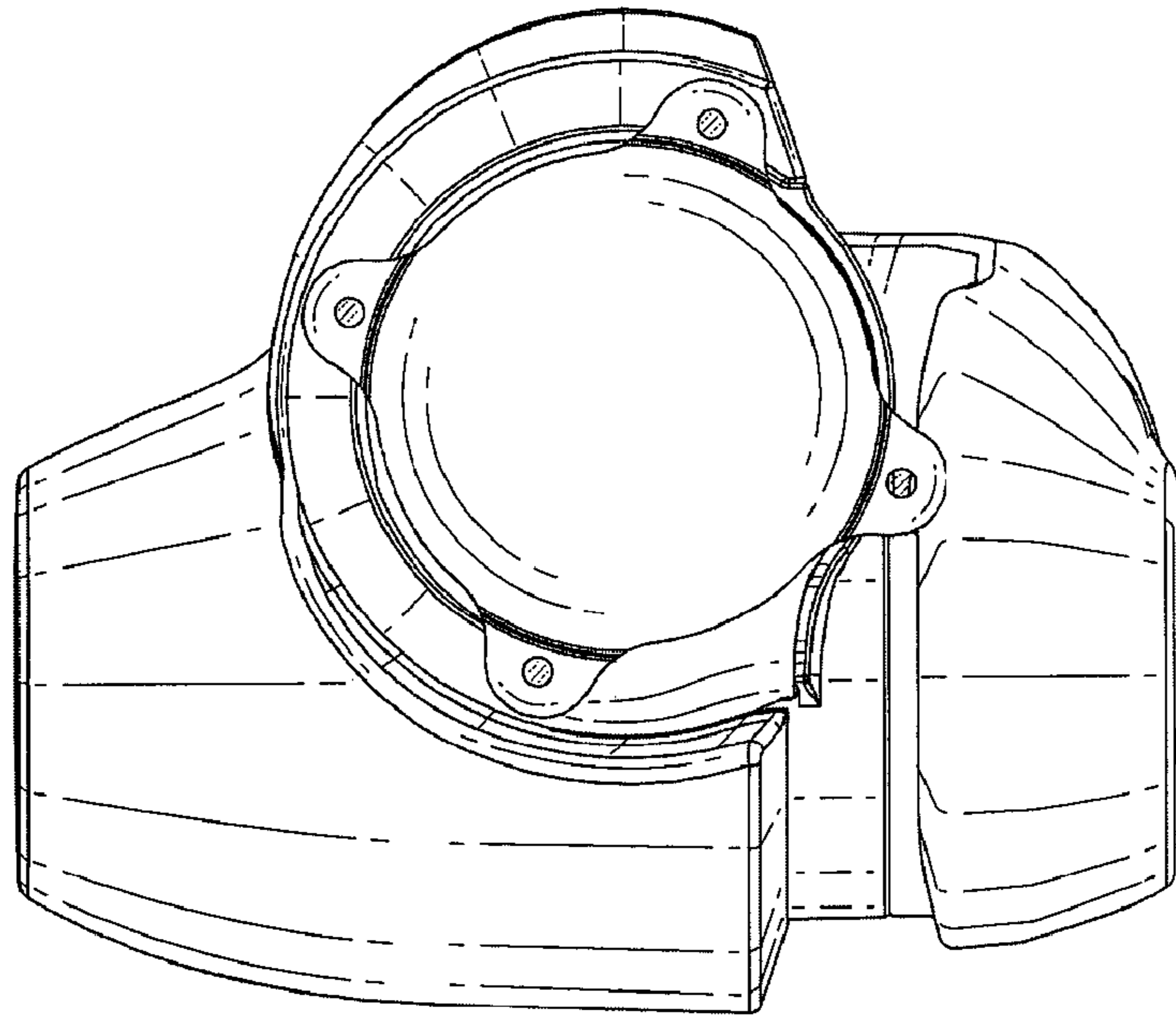

FIG. 14

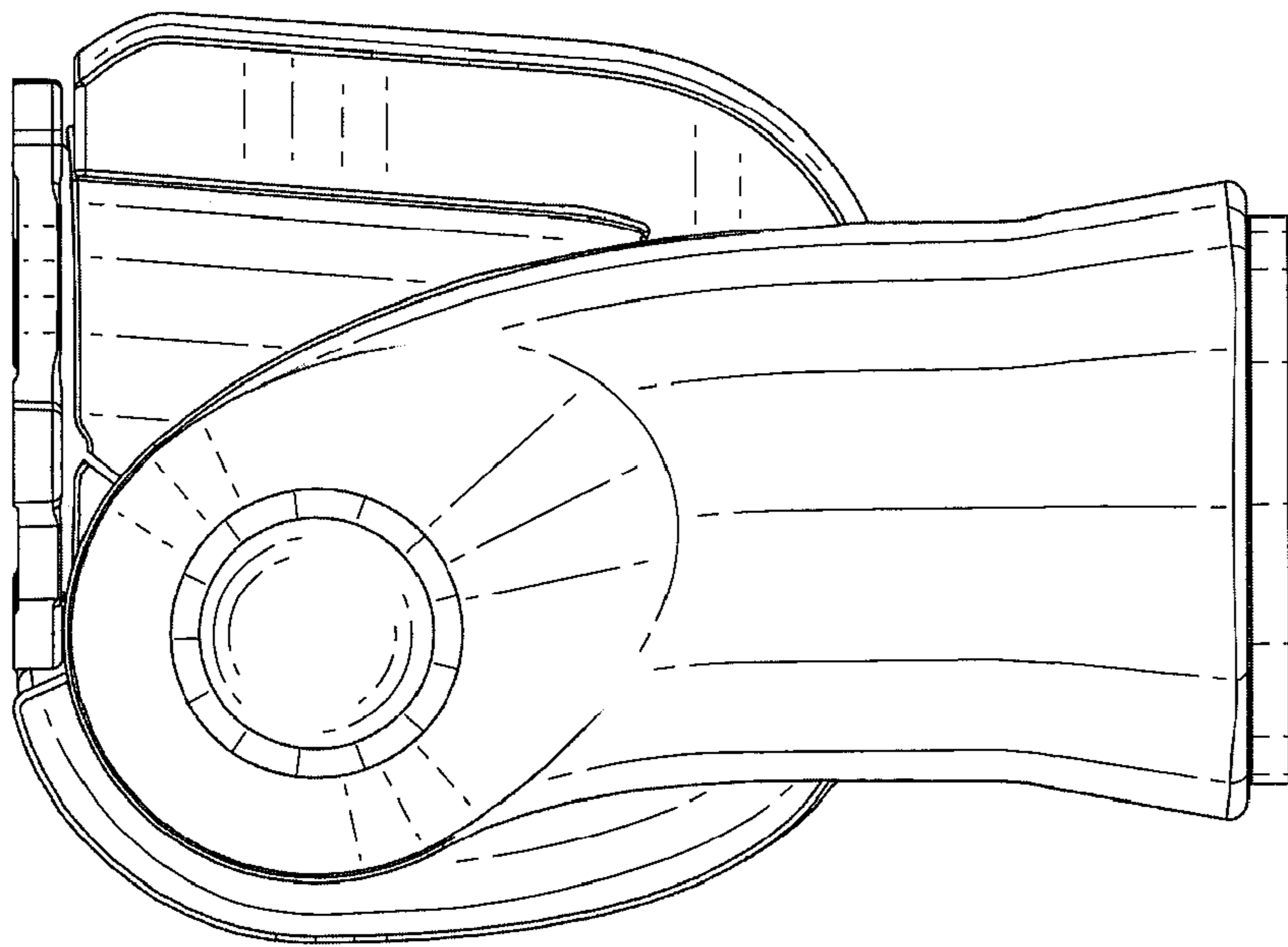

FIG. 15

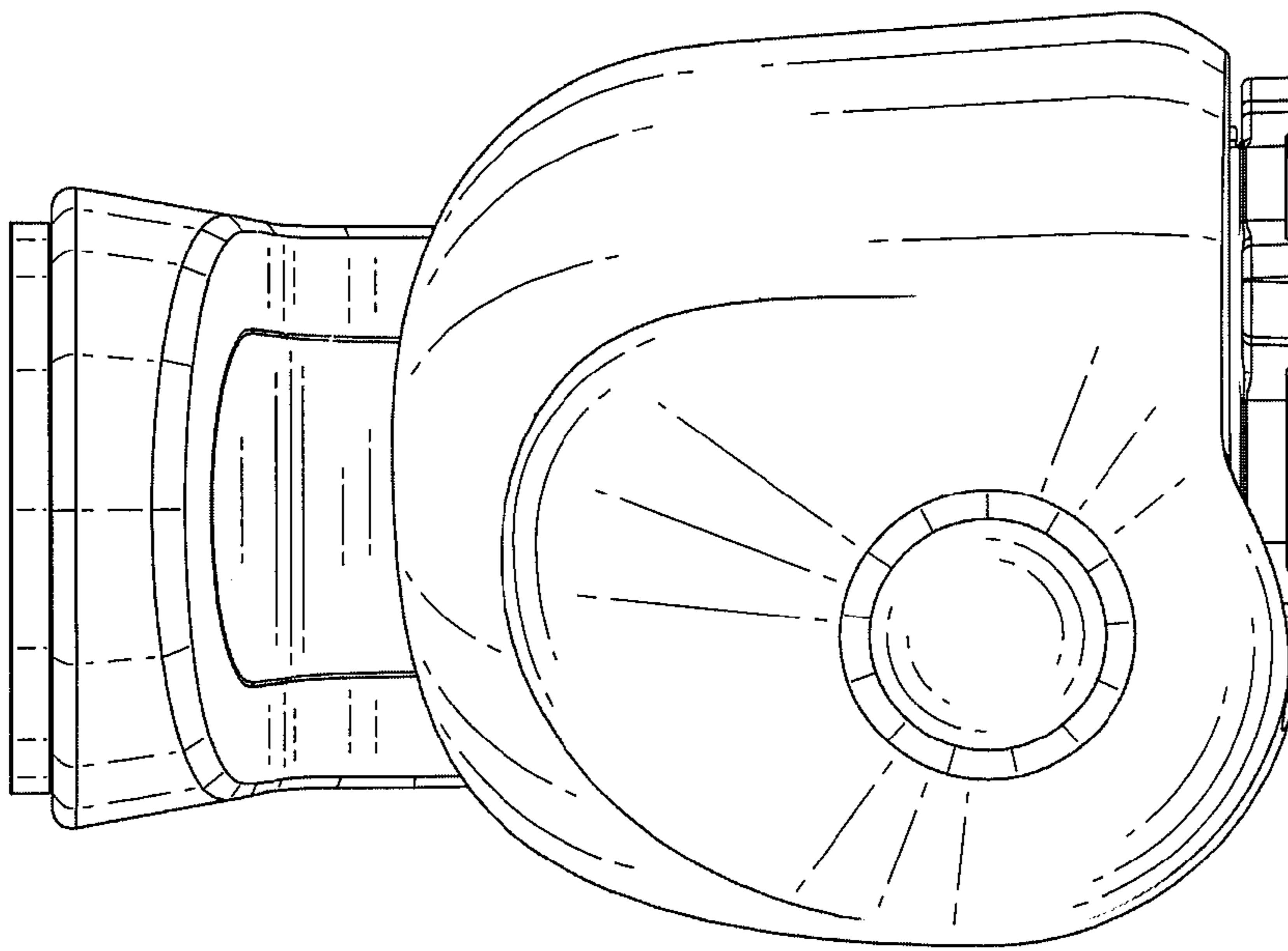

FIG. 16



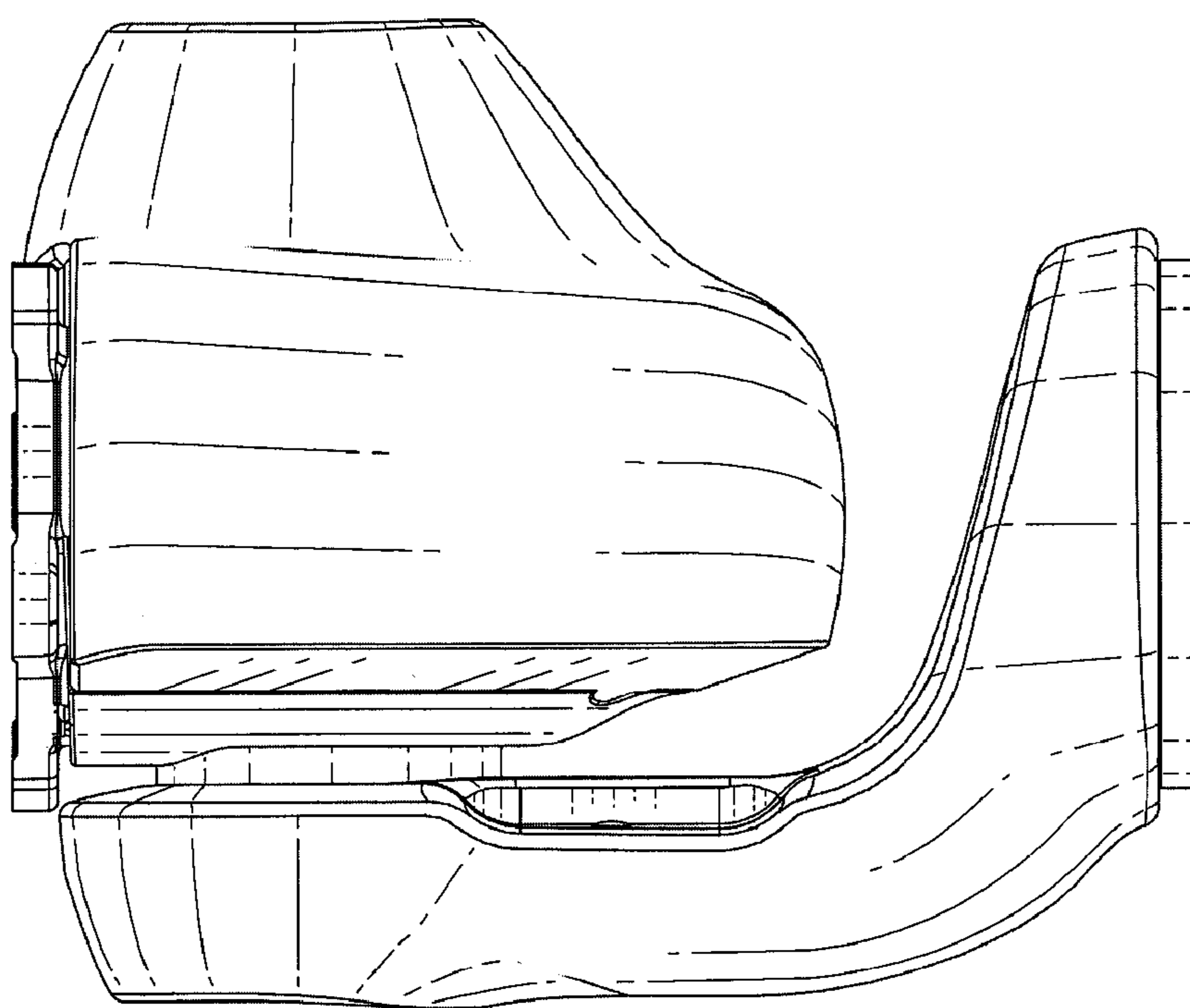

FIG. 17

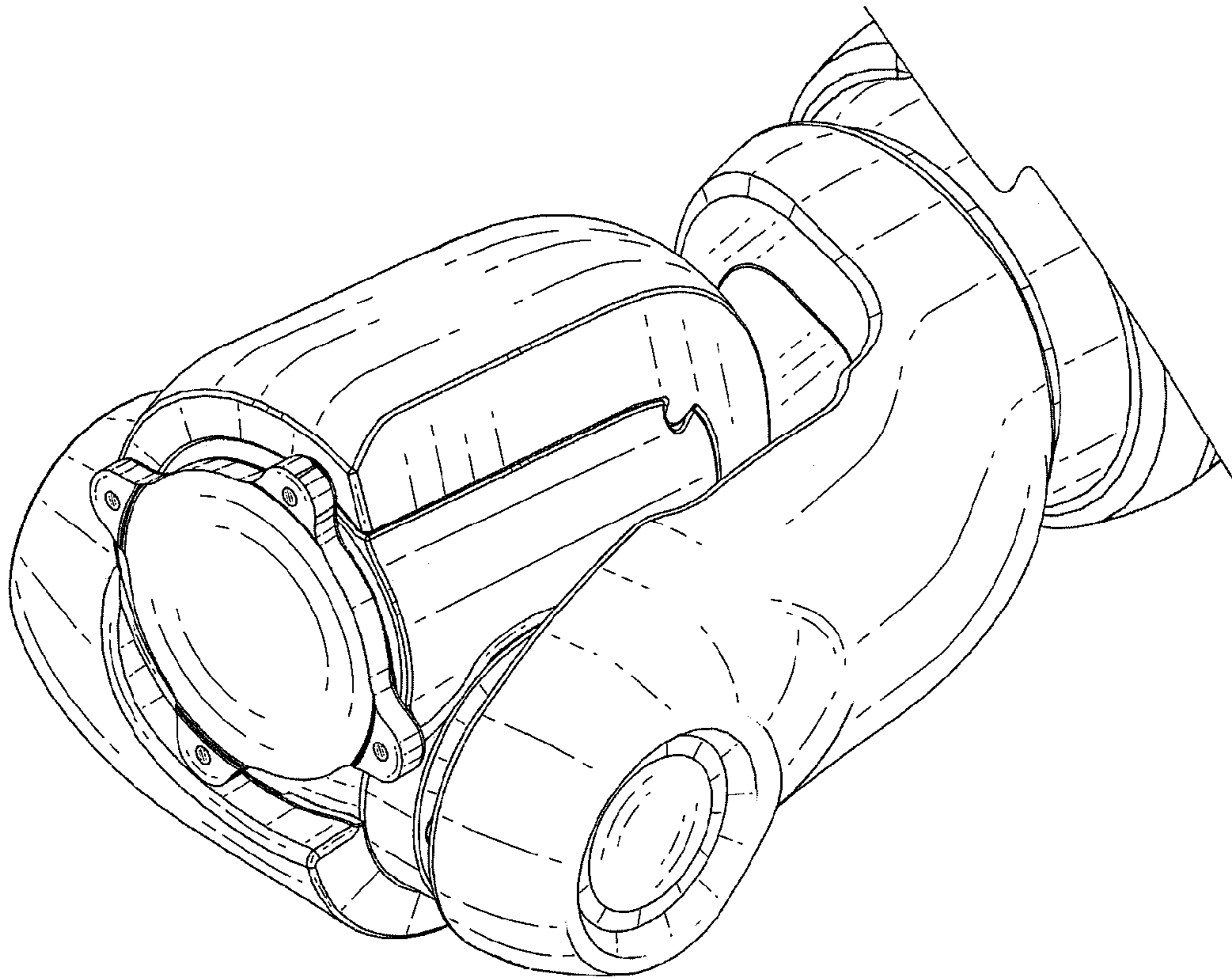

FIG. 18