



US00D646549S

(12) **United States Design Patent**  
**Mussi et al.**

(10) **Patent No.:** **US D646,549 S**

(45) **Date of Patent:** **\*\* \*Oct. 11, 2011**

(54) **PADDLE TRIM ASSEMBLY**

(75) Inventors: **Marcio Stella Mussi**, Sao Paulo (BR);  
**Donald T. Shamp**, Northford, CT (US);  
**Darren C. Eller**, East Lyme, CT (US);  
**Christopher C. Hill**, New Britain, CT  
(US); **Andrew Stephen Geraci**,  
Branford, CT (US); **Bryce A. Fleury**,  
West Hartford, CT (US)

(73) Assignee: **Sargent Manufacturing Company**,  
New Haven, CT (US)

(\*) Notice: This patent is subject to a terminal dis-  
claimer.

(\*\*) Term: **14 Years**

(21) Appl. No.: **29/361,228**

(22) Filed: **May 7, 2010**

(51) **LOC (9) Cl.** ..... **08-06**

(52) **U.S. Cl.** ..... **D8/302**

(58) **Field of Classification Search** ..... D8/302,  
D8/300, 301, 303-310, 313, 314, 315, 331-338,  
D8/341; 70/77-79, 84, 90, 91, 101, 141,  
70/162, 208, 286, 287; 292/95, 170, 175,  
292/202, 336.3

See application file for complete search history.

(56) **References Cited**

U.S. PATENT DOCUMENTS

D230,945 S *	3/1974	Beckman	.....	D8/341
5,413,391 A *	5/1995	Clavin et al.	.....	292/170
D369,089 S *	4/1996	Zenner	.....	D8/343
D370,620 S *	6/1996	Zierner	.....	D8/341
D385,474 S *	10/1997	Rechberg	.....	D8/313

D390,443 S *	2/1998	Zenner	.....	D8/331
D419,053 S *	1/2000	Schlack	.....	D8/339
6,109,669 A *	8/2000	Pinkow	.....	292/175
6,145,352 A *	11/2000	Vickers et al.	.....	70/208
D465,142 S *	11/2002	Weinerman et al.	.....	D8/302
D465,399 S *	11/2002	Weinerman et al.	.....	D8/302
D502,380 S *	3/2005	Misner et al.	.....	D8/302
D505,310 S *	5/2005	Lorusso	.....	D8/302
D533,045 S *	12/2006	Schroth	.....	D8/300
D537,321 S *	2/2007	Paige et al.	.....	D8/338
D541,129 S *	4/2007	Helton et al.	.....	D8/301
D577,984 S *	10/2008	Samhammer et al.	.....	D8/338

\* cited by examiner

*Primary Examiner* — Stella Reid

*Assistant Examiner* — Derrick Holland

(74) *Attorney, Agent, or Firm* — DeLio & Peterson, LLC

(57) **CLAIM**

The ornamental design for a “paddle trim assembly,” as shown and described.

**DESCRIPTION**

FIG. 1 is a left side perspective view of a paddle trim assembly showing our new design in environmental use;  
FIG. 2 is a front elevational view thereof;  
FIG. 3 is a left side elevational view thereof;  
FIG. 4 is a right side elevational view thereof;  
FIG. 5 is a top plan view thereof;  
FIG. 6 is a right side perspective view thereof; and,  
FIG. 7 is a front elevational view thereof, rotated 90 degrees of that shown in FIG. 2.

The back view of the “paddle trim assembly” which is not shown forms no part of the design.

The broken lines shown represent unclaimed subject matter and form no part of the claimed design.

**1 Claim, 3 Drawing Sheets**

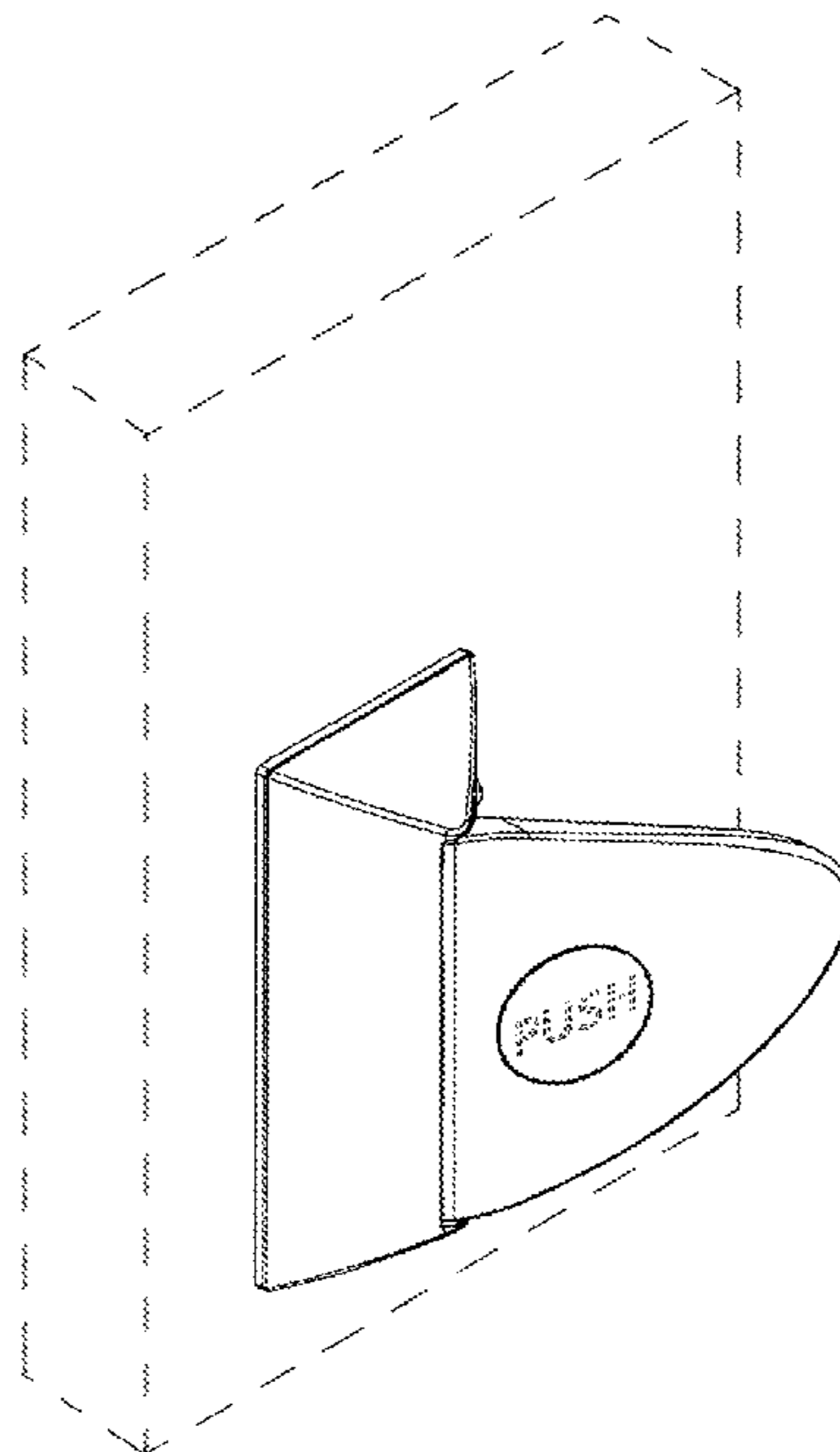

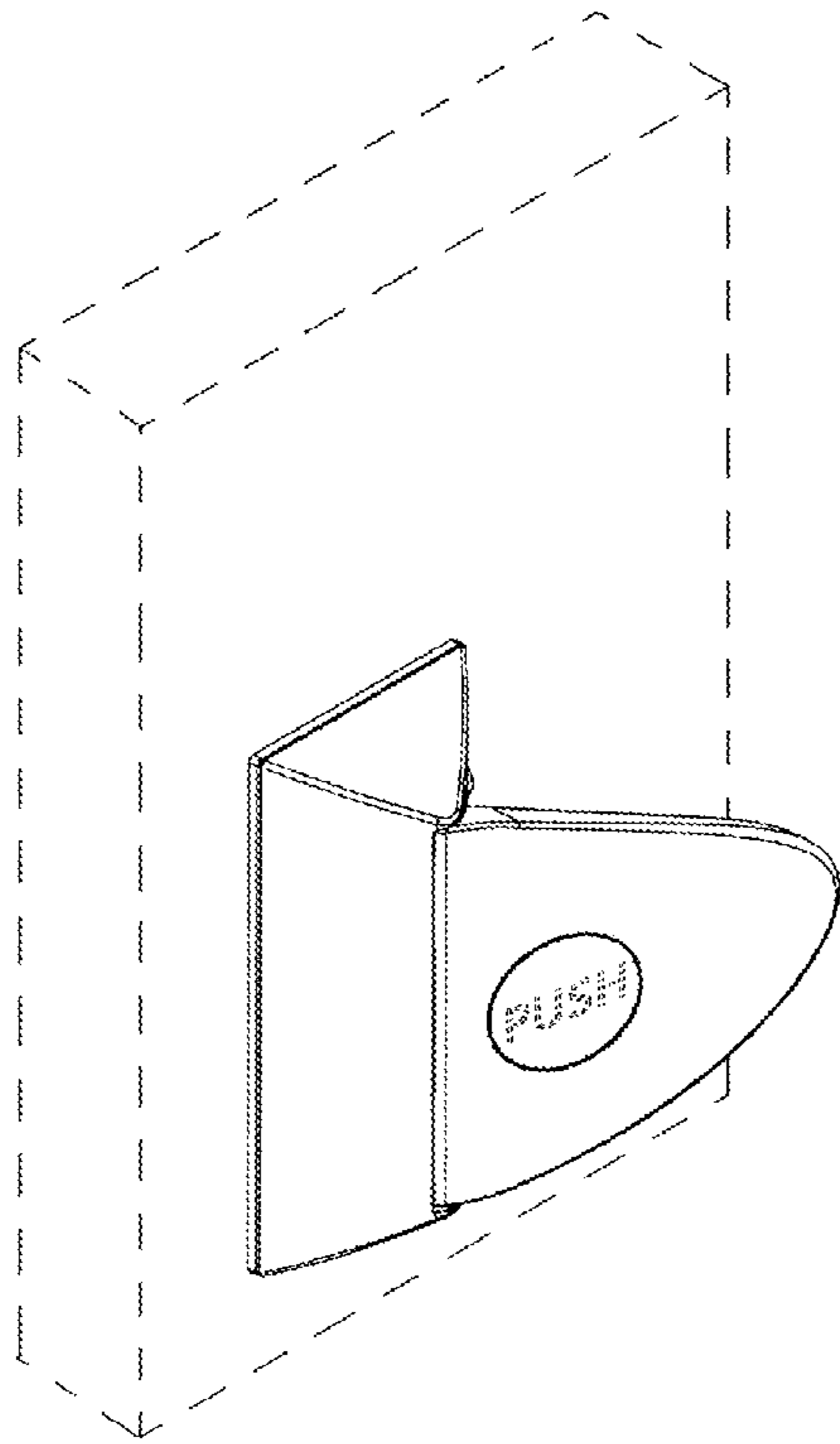

FIG. 1

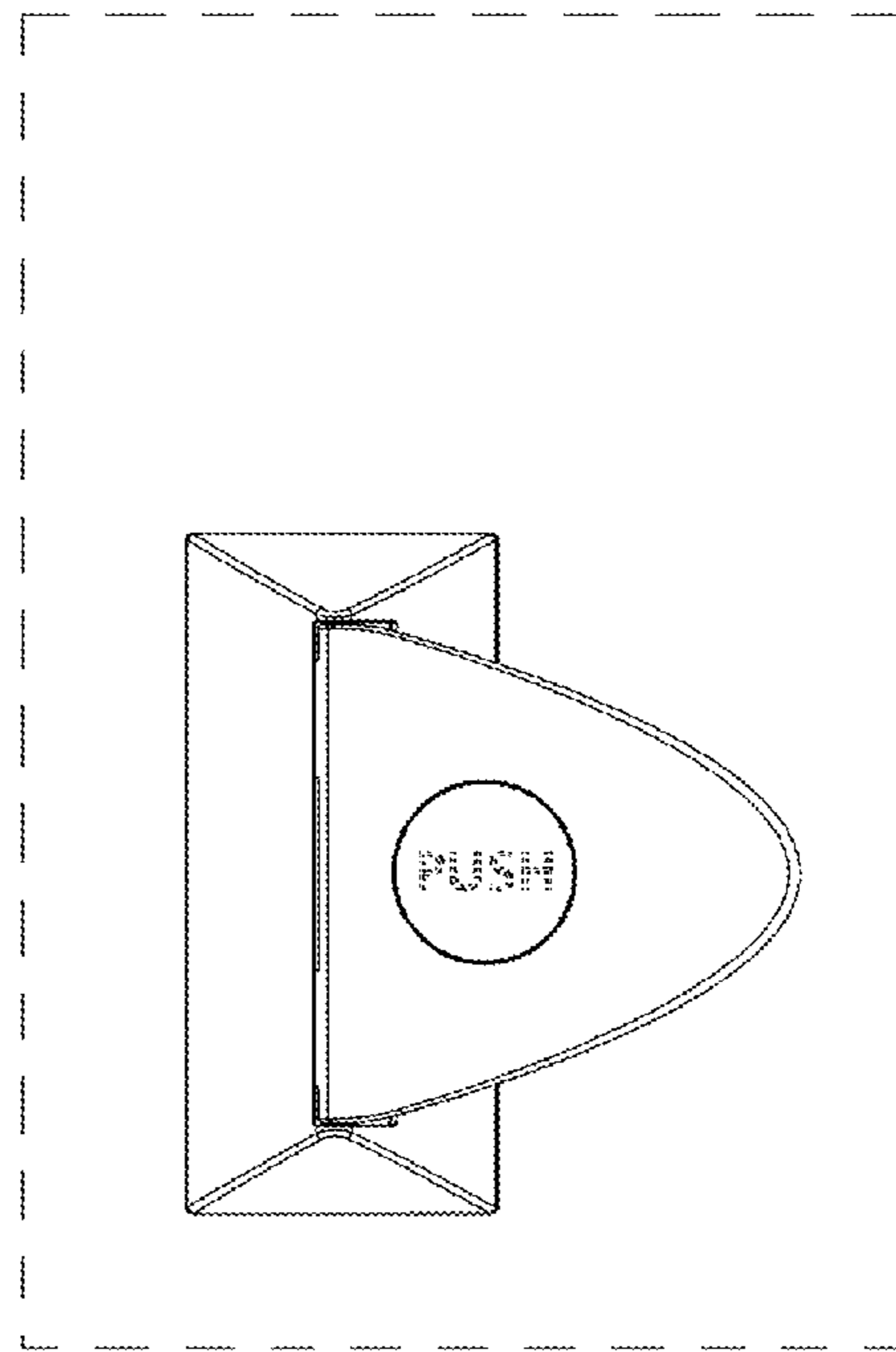

FIG. 2

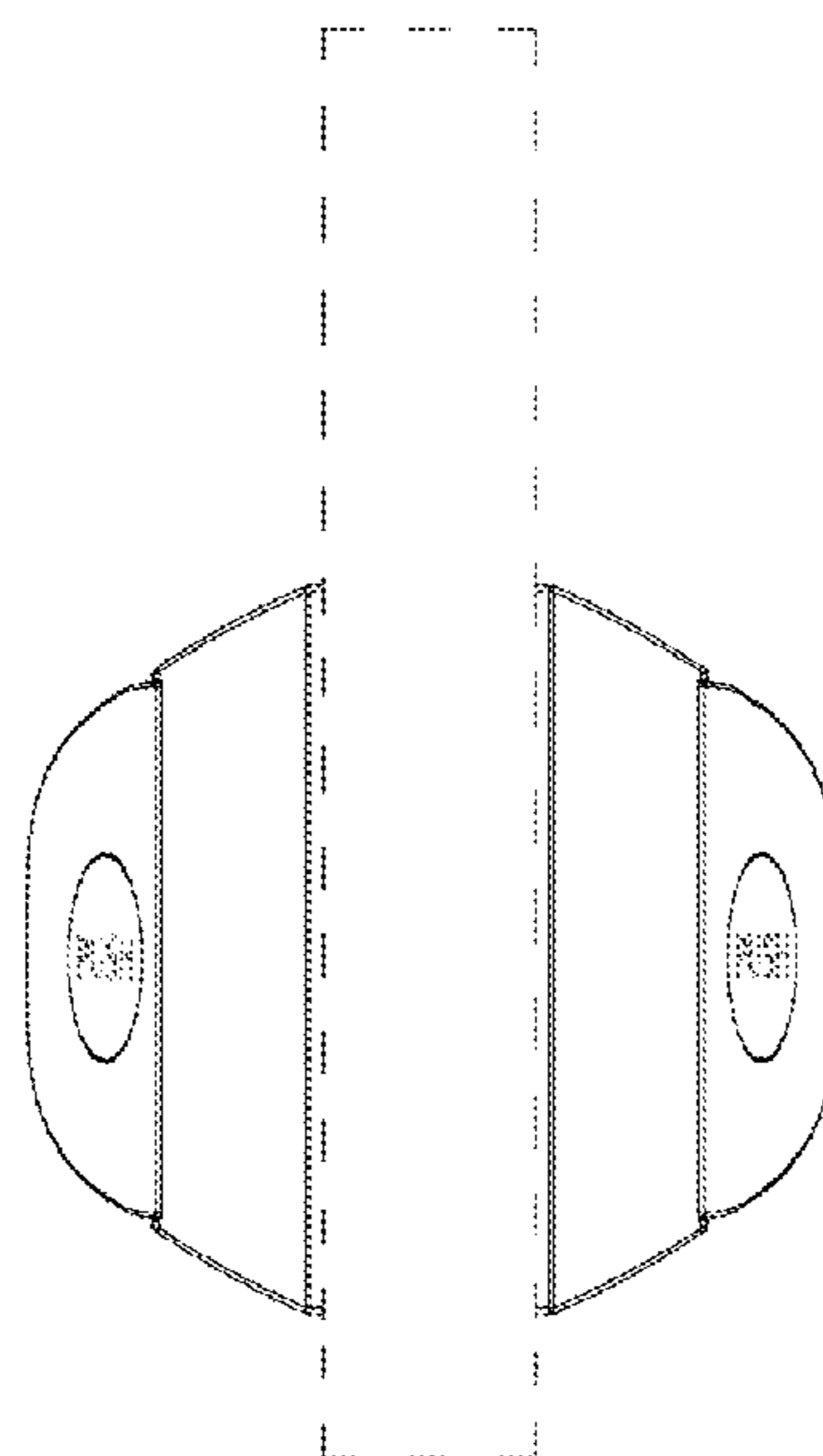

FIG. 3

FIG. 4

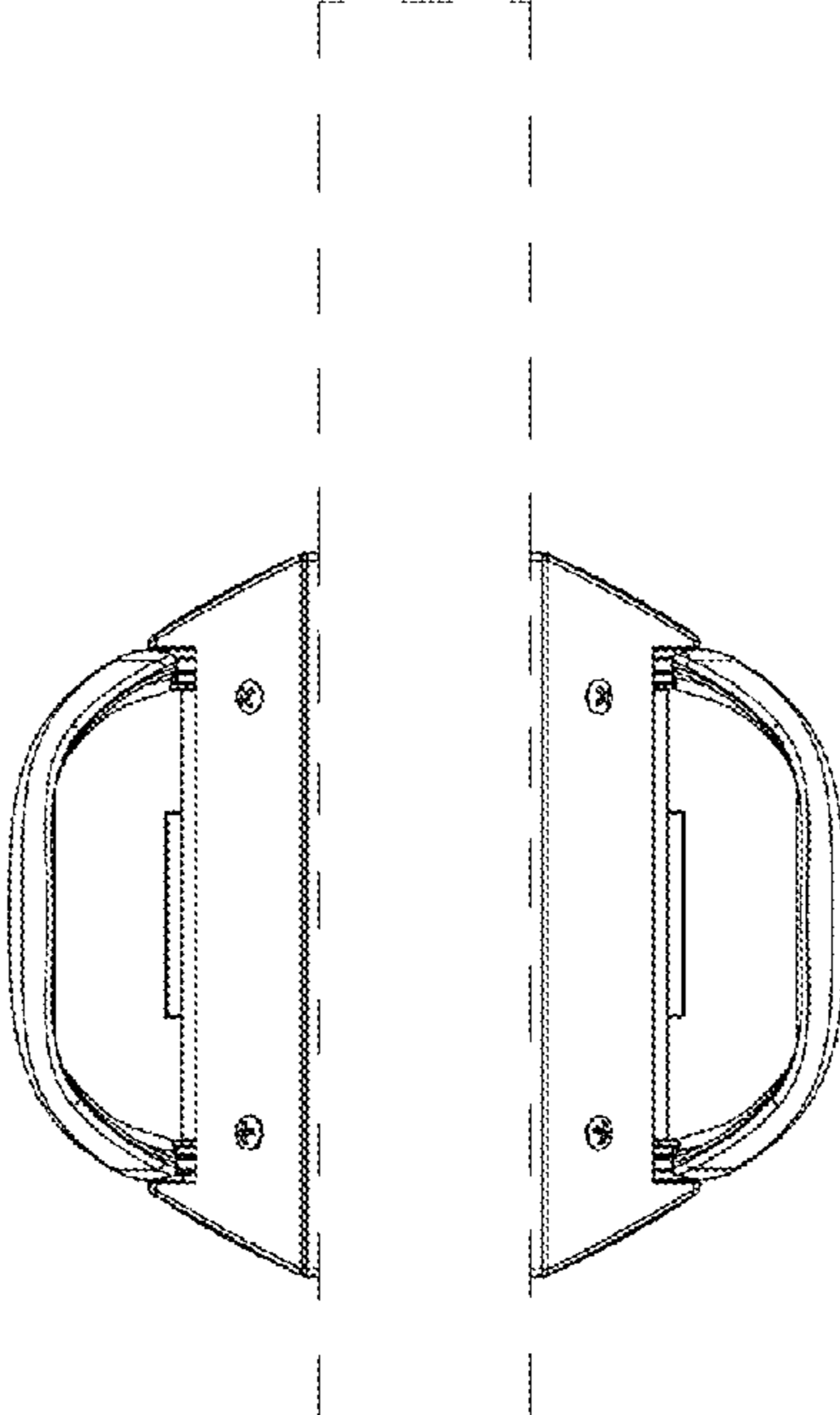
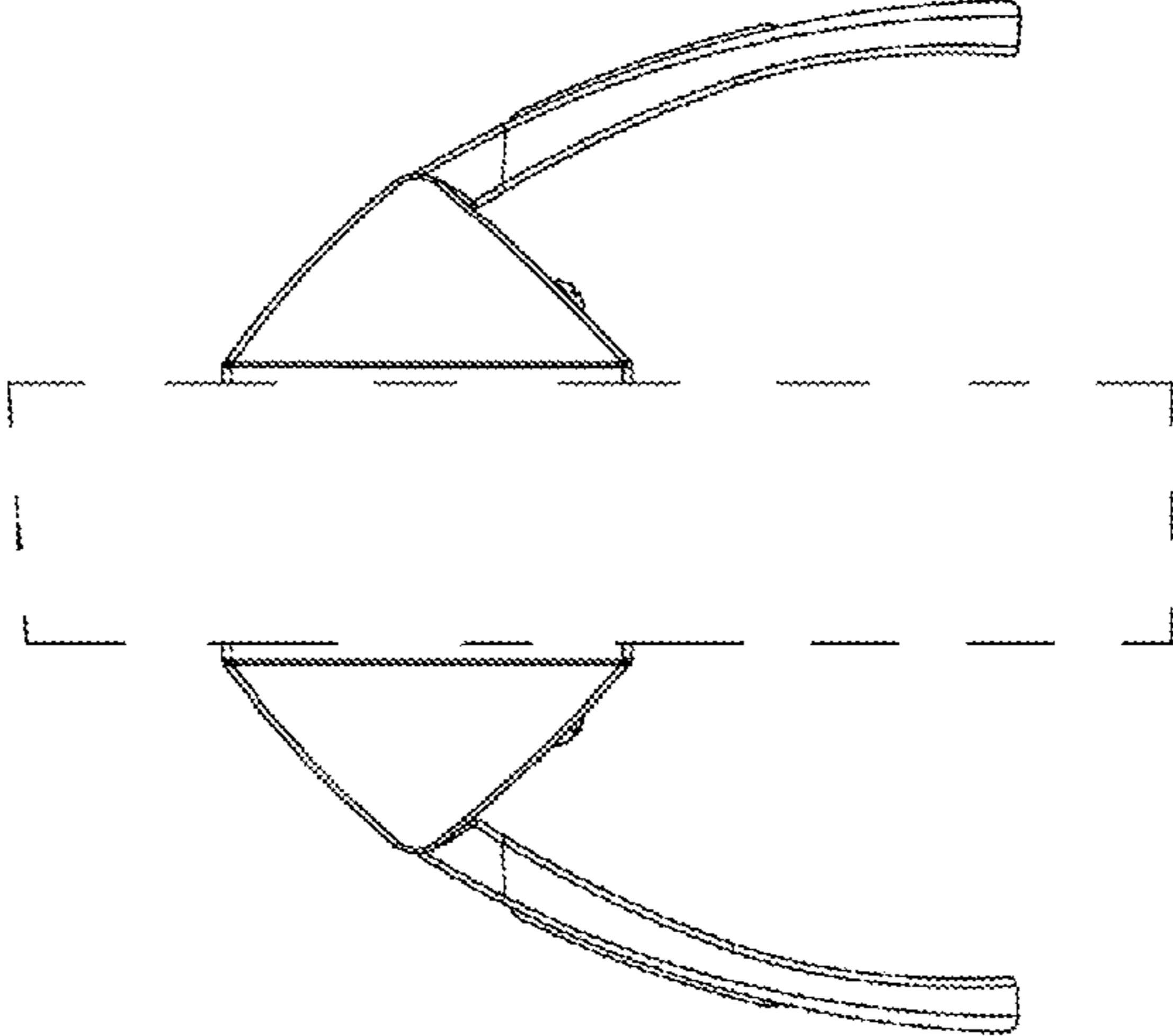

FIG. 5



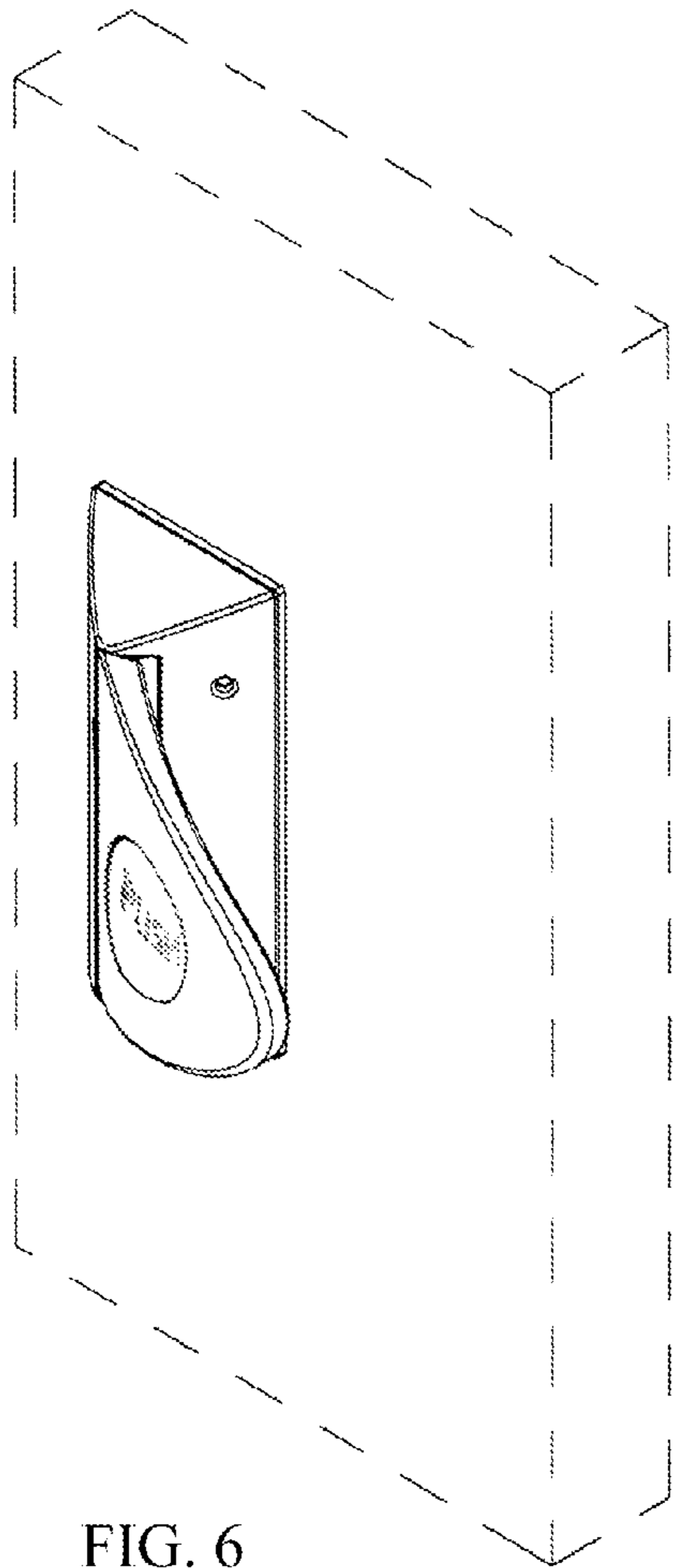

FIG. 6

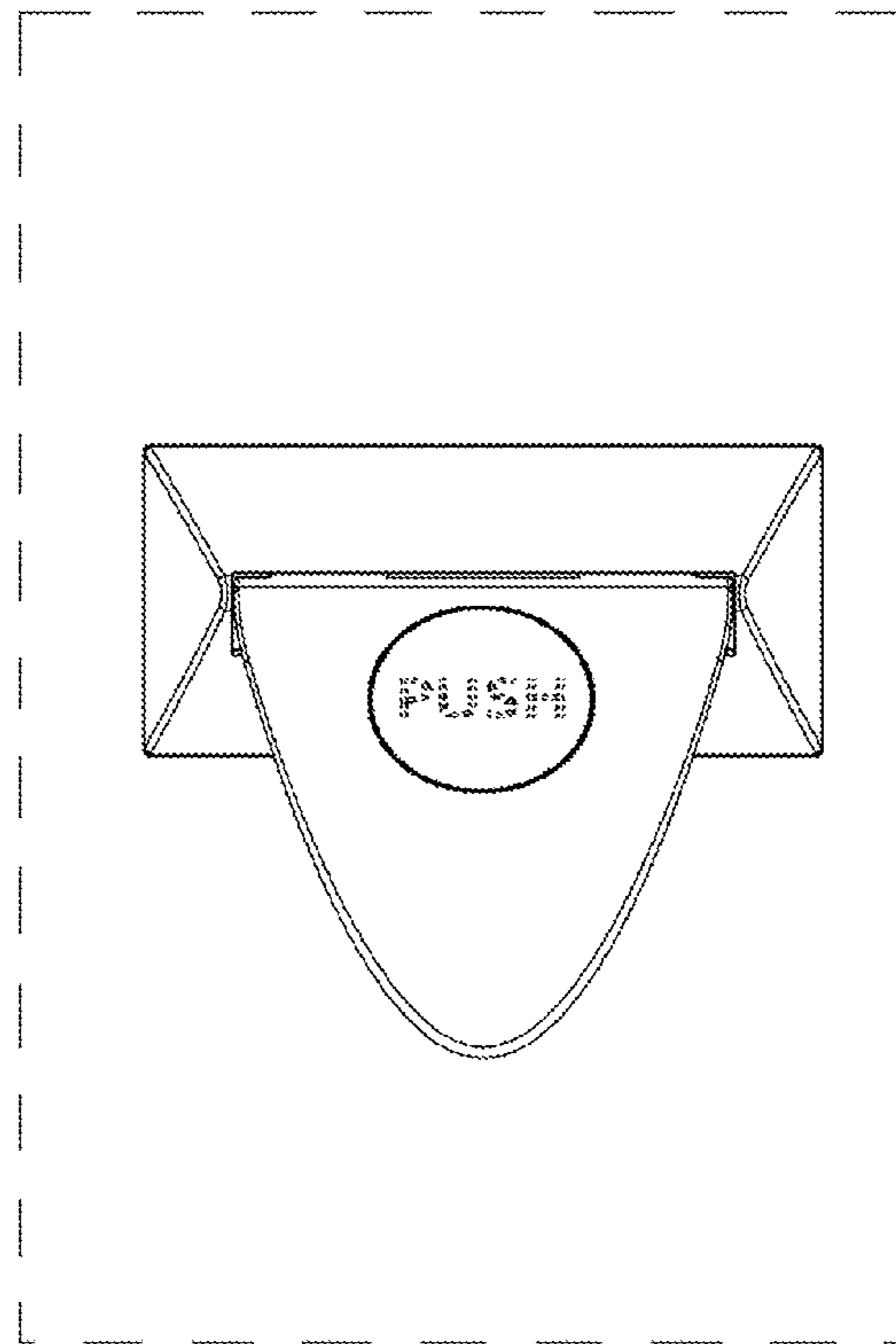

FIG. 7