



US00D646154S

(12) **United States Design Patent**  
**Andersson**

(10) **Patent No.:** **US D646,154 S**

(45) **Date of Patent:** **\*\* Oct. 4, 2011**

(54) **LOCK NUT**

(75) Inventor: **Mattias Andersson**, Mattmar (SE)

(73) Assignee: **Nord-Lock AB** (SE)

(\*\*) Term: **14 Years**

(21) Appl. No.: **29/353,229**

(22) Filed: **Jan. 5, 2010**

(30) **Foreign Application Priority Data**

Jul. 6, 2009 (EP) ..... 001572124-0001

Jul. 6, 2009 (EP) ..... 001572124-0002

(51) **LOC (9) Cl.** ..... **08-08**

(52) **U.S. Cl.** ..... **D8/397**

(58) **Field of Classification Search** ..... D8/397,  
D8/399, 394, 382, 349, 8, 323; D15/138;  
D23/262, 259; 411/432, 108, 353, 404, 410,  
411/919, 147, 957; 137/383; D21/488  
See application file for complete search history.

(56) **References Cited**

**U.S. PATENT DOCUMENTS**

|               |         |                |       |          |
|---------------|---------|----------------|-------|----------|
| D26,801 S *   | 3/1897  | Spear          | ..... | D8/399   |
| D28,212 S *   | 1/1898  | Biedenfeld     | ..... | D8/397   |
| D32,218 S *   | 2/1900  | Dougherty      | ..... | D8/399   |
| D32,492 S *   | 4/1900  | Dickason       | ..... | D8/399   |
| 2,001,956 A * | 5/1935  | England        | ..... | 470/42   |
| 4,134,438 A * | 1/1979  | Friberg et al. | ..... | 411/163  |
| D263,679 S *  | 4/1982  | Friberg        | ..... | D8/399   |
| D263,791 S *  | 4/1982  | Friberg        | ..... | D8/399   |
| D263,792 S *  | 4/1982  | Friberg        | ..... | D8/399   |
| 4,389,766 A * | 6/1983  | Capuano        | ..... | 29/432.2 |
| D269,852 S *  | 7/1983  | Friberg        | ..... | D8/399   |
| D273,562 S *  | 4/1984  | Friberg        | ..... | D8/399   |
| D276,310 S *  | 11/1984 | Friberg        | ..... | D8/399   |

|                   |         |               |       |         |
|-------------------|---------|---------------|-------|---------|
| 5,011,351 A *     | 4/1991  | Terry         | ..... | 411/144 |
| D453,000 S *      | 1/2002  | Shinjo et al. | ..... | D8/397  |
| D459,207 S *      | 6/2002  | Miyata        | ..... | D8/397  |
| D512,886 S *      | 12/2005 | Christensen   | ..... | D8/14   |
| D551,972 S *      | 10/2007 | Jacobs et al. | ..... | D9/445  |
| 7,568,874 B2 *    | 8/2009  | Riedel et al. | ..... | 411/435 |
| D602,349 S *      | 10/2009 | Andersson     | ..... | D8/399  |
| D609,999 S *      | 2/2010  | Andersson     | ..... |         |
| D614,247 S *      | 4/2010  | Clausen       | ..... | D21/488 |
| 2002/0136617 A1 * | 9/2002  | Imahigashi    | ..... | 411/533 |

**OTHER PUBLICATIONS**

“Indian Design Application Serial No. 226267, First Examination Report dated Feb. 25, 2010”, 2 pgs.

\* cited by examiner

*Primary Examiner* — Cynthia Underwood

(74) *Attorney, Agent, or Firm* — Schwegman, Lundberg & Woessner, P.A.

(57) **CLAIM**

The ornamental design for a lock nut, as shown and described.

**DESCRIPTION**

FIG. 1 is a front/top side perspective view of the lock nut according to my design;

FIG. 2 is a front view with the top side oriented up thereof;

FIG. 3 is a back view with the top side oriented down thereof;

FIG. 4 is a right side view with the top side oriented to the right thereof;

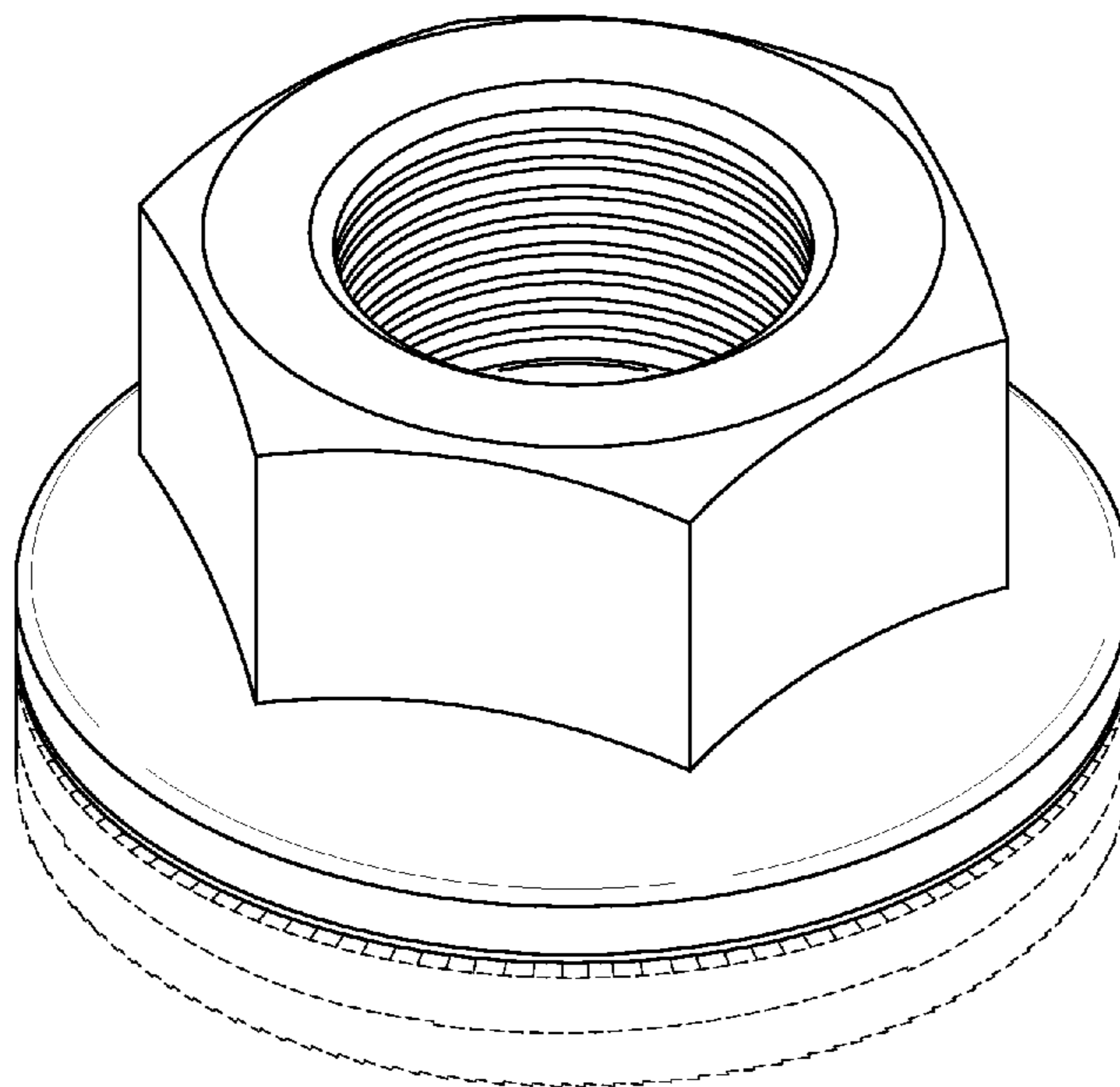
FIG. 5 is a left side view with the top side oriented to the left thereof;

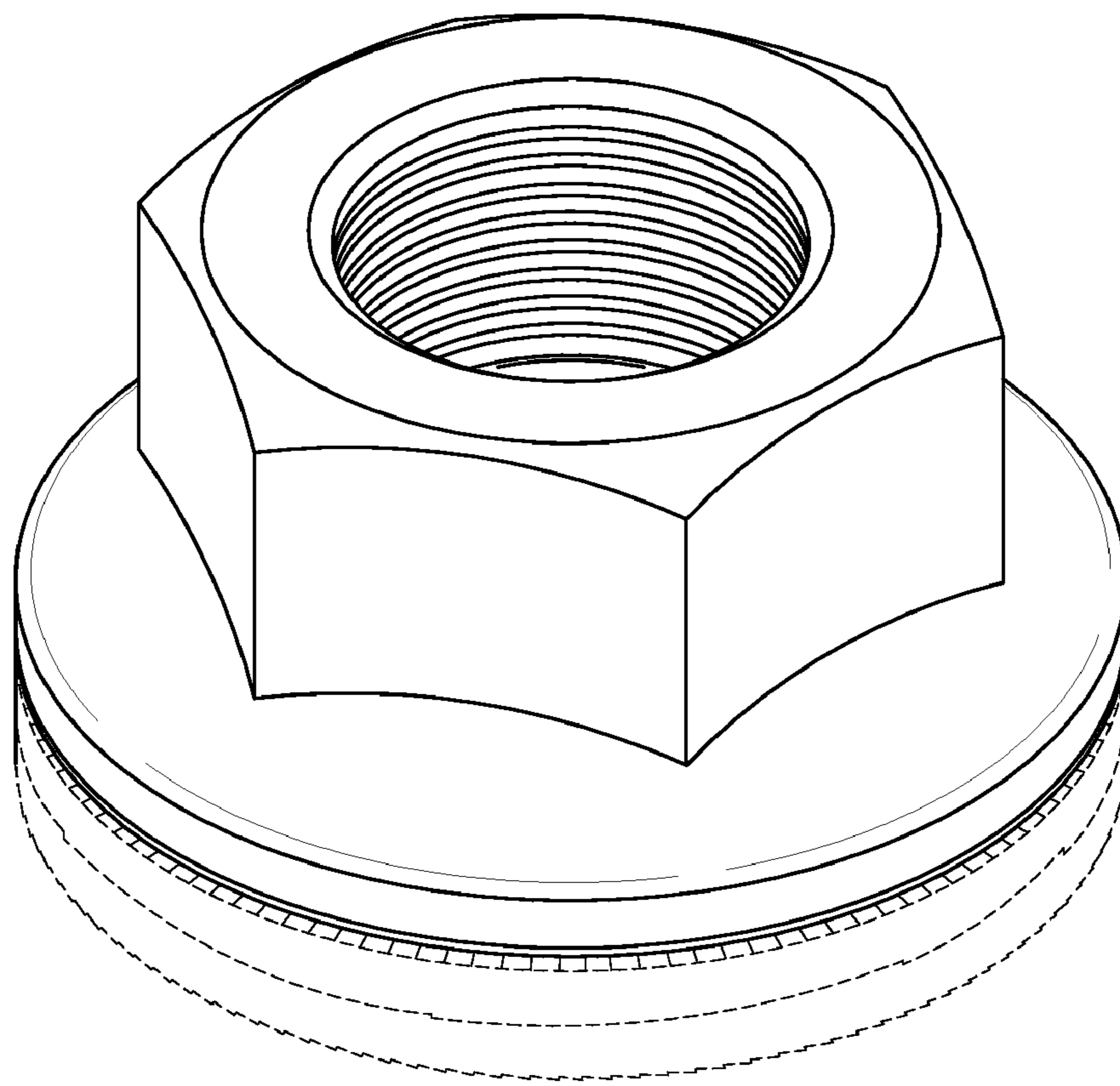
FIG. 6 is a top view thereof; and,

FIG. 7 is a bottom view thereof.

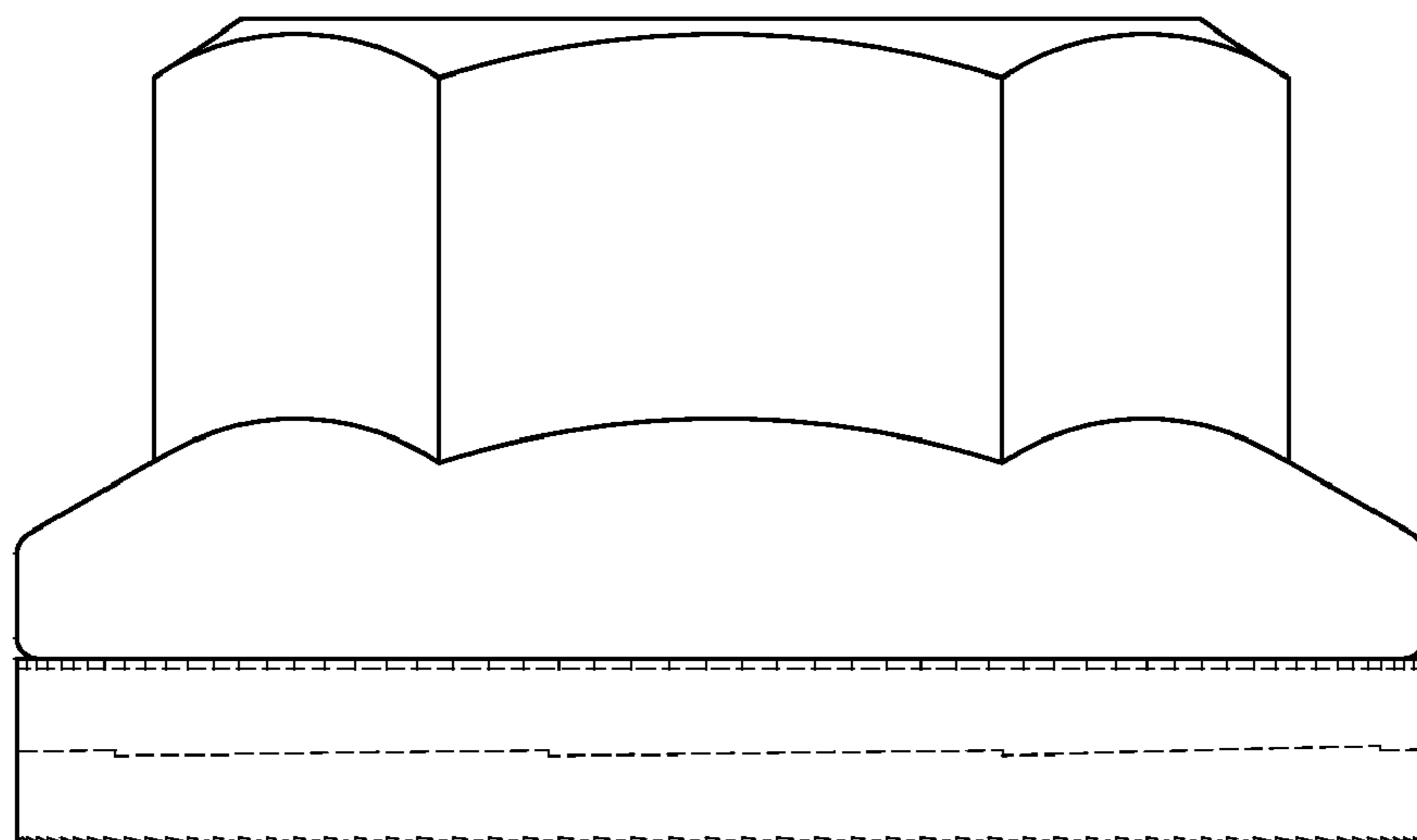
The broken lines are included for the purpose of illustrating portions of the structure that form no part of the claimed design.

**1 Claim, 6 Drawing Sheets**

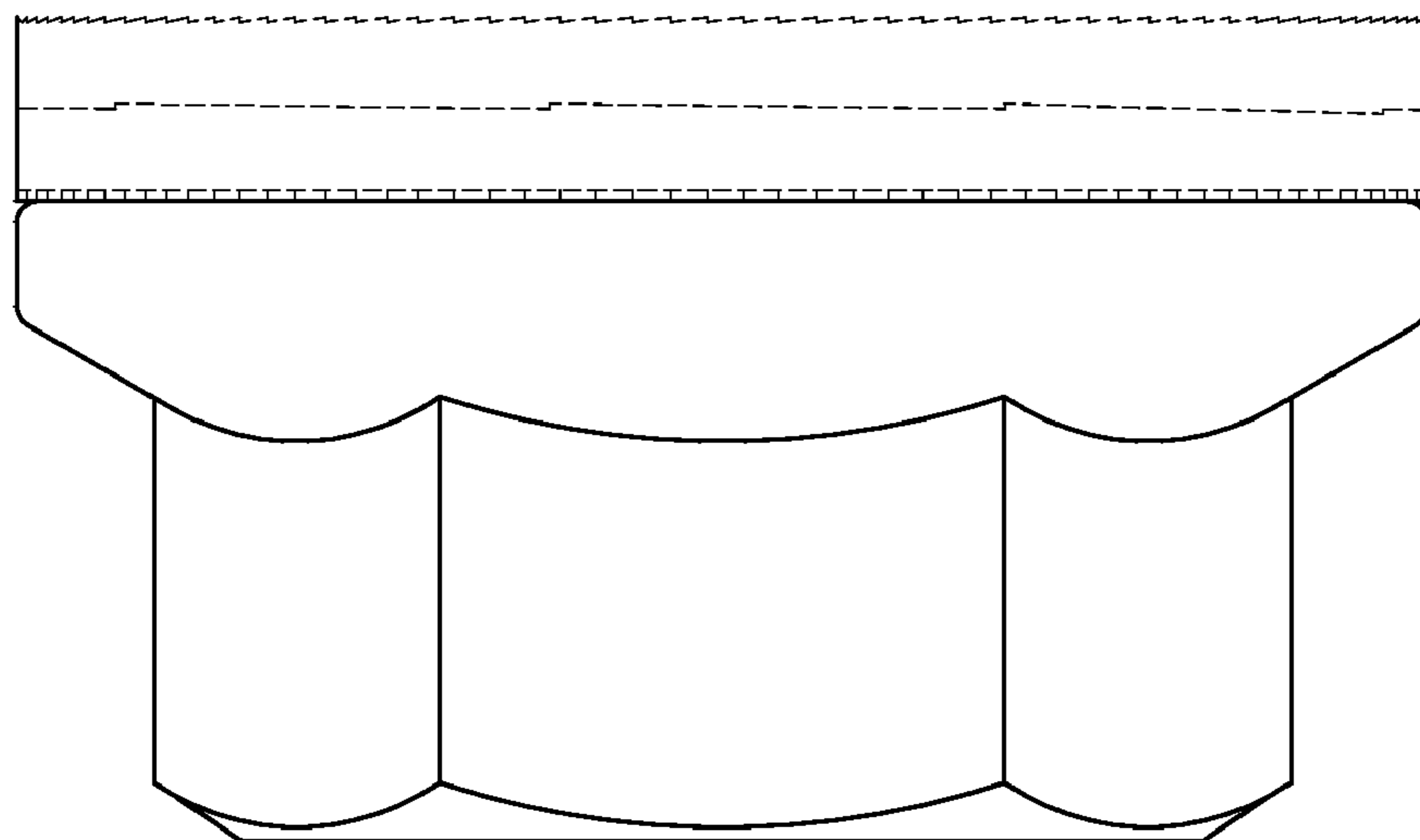




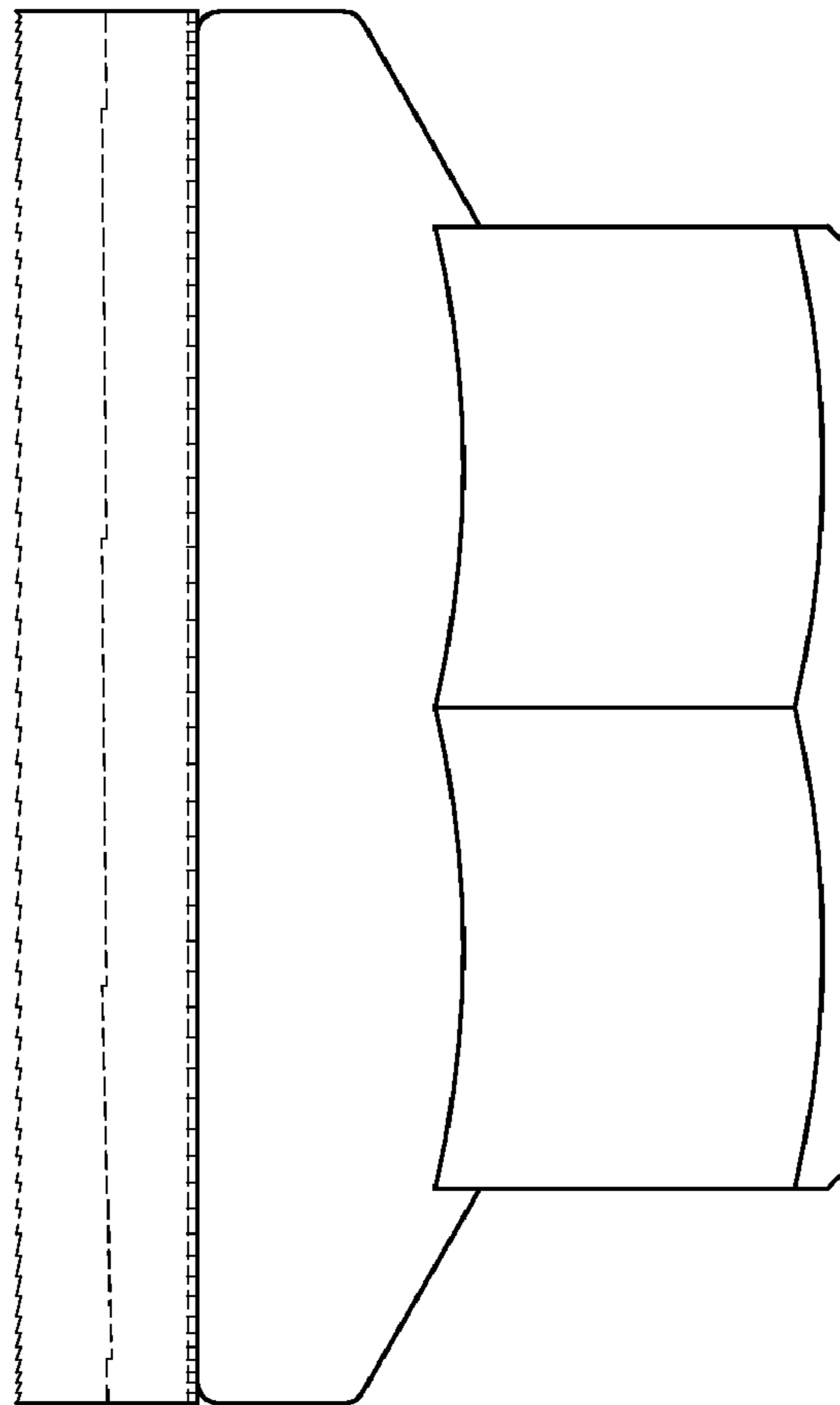
*FIG. 1*



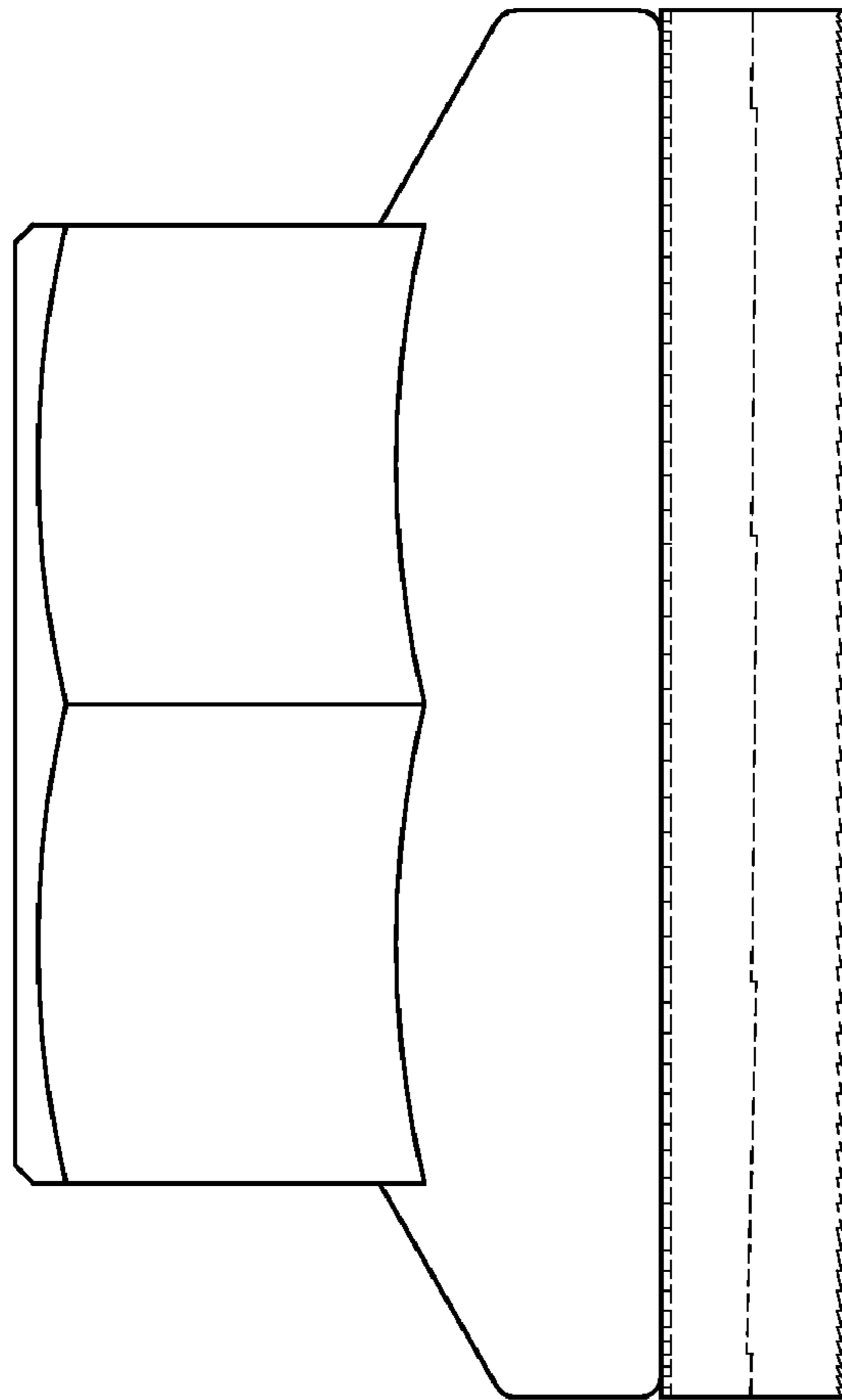
*FIG. 2*



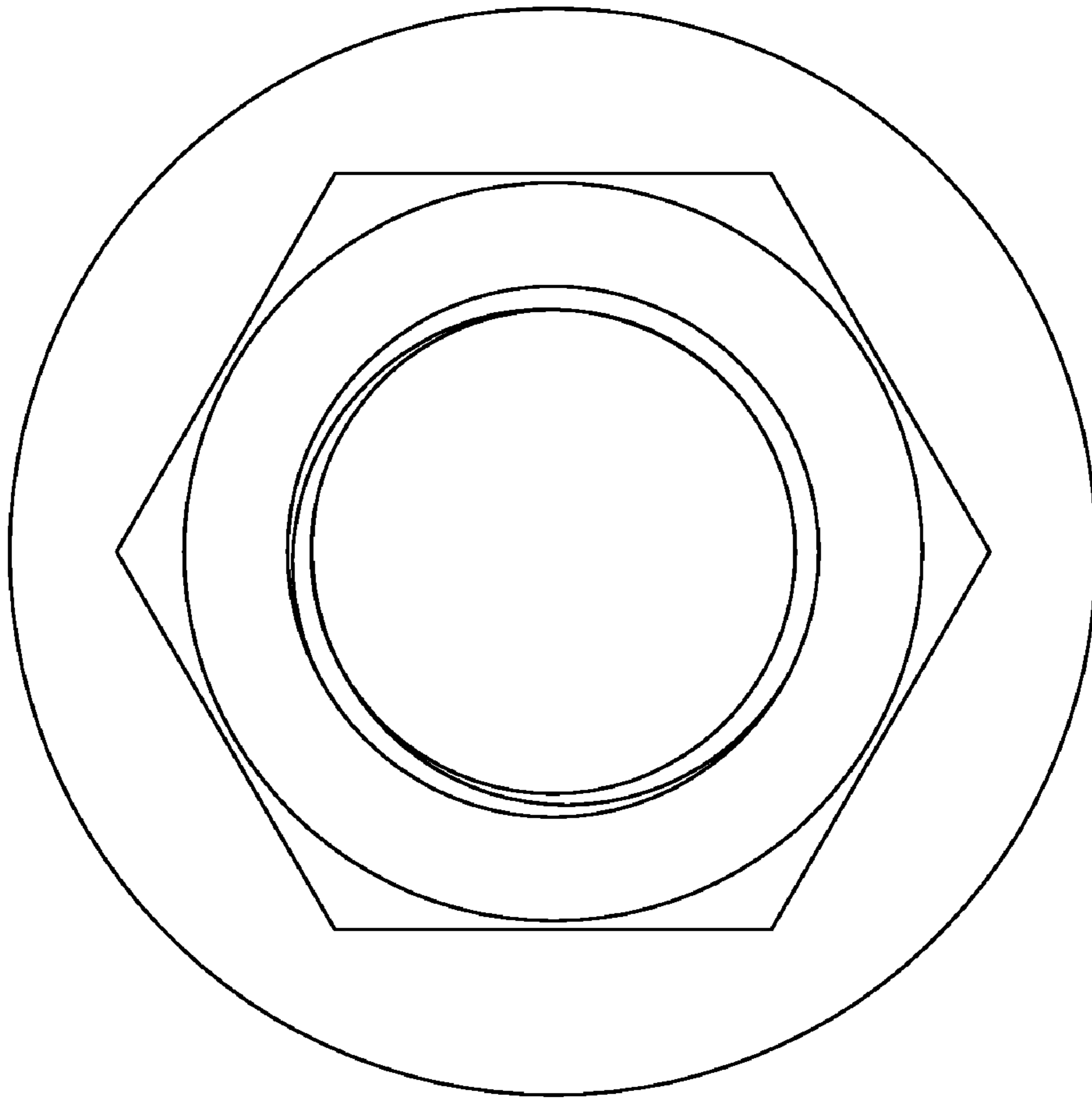
*FIG. 3*



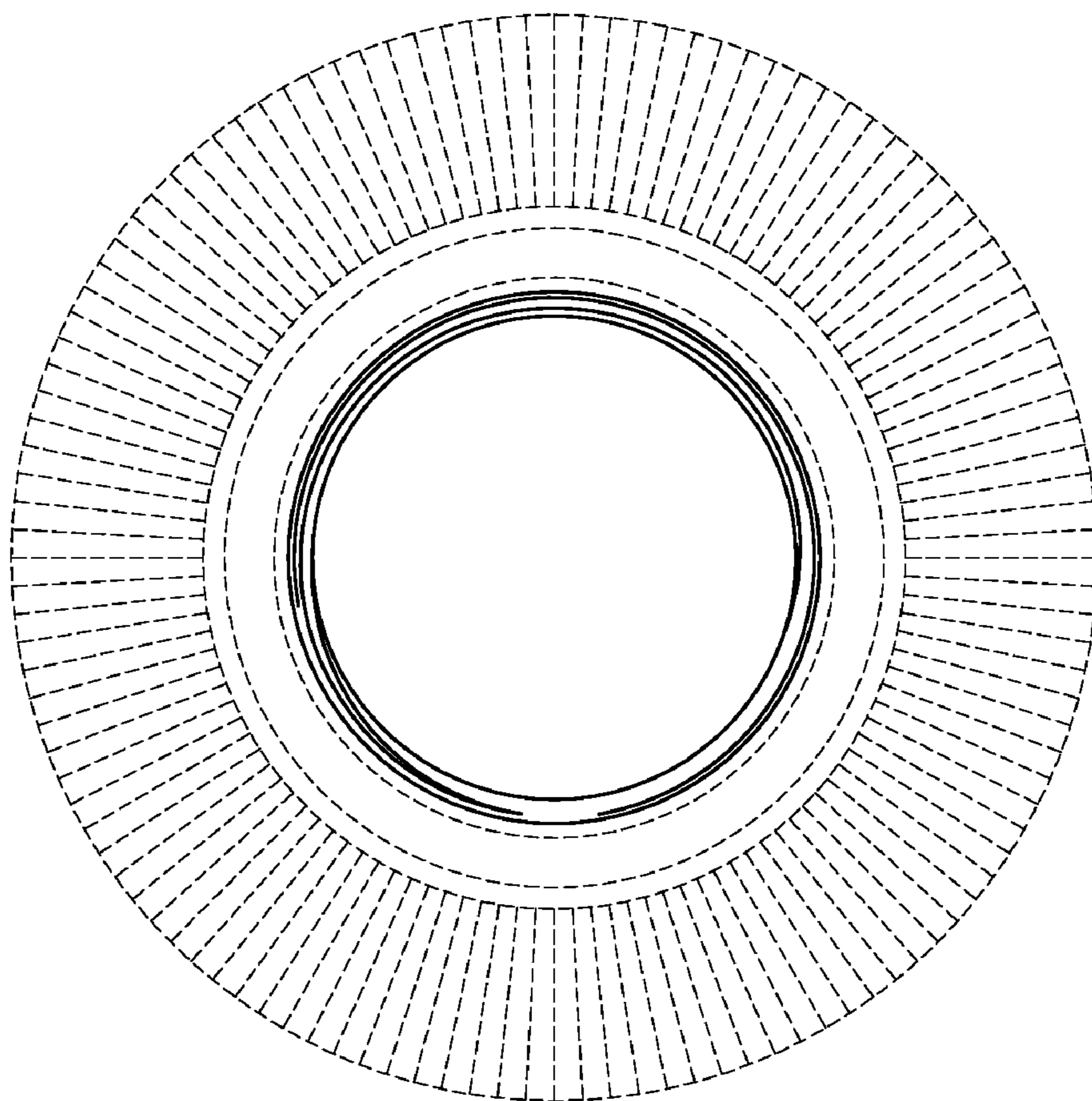
*FIG. 4*



*FIG. 5*



*FIG. 6*



*FIG. 7*