



US00D645913S

(12) **United States Design Patent**
Beauregard et al.

(10) **Patent No.:** **US D645,913 S**

(45) **Date of Patent:** **** Sep. 27, 2011**

- (54) **TOY VEHICLE TRACK LINK**
- (75) Inventors: **Thierry Beauregard**, Boisbriand (CA);
Patrice Paquette, Melbourne (CA)
- (73) Assignee: **MEGA Brands Inc.**, Montreal, Quebec
(CA)
- (**) Term: **14 Years**
- (21) Appl. No.: **29/379,298**
- (22) Filed: **Nov. 17, 2010**
- (51) **LOC (9) Cl.** **21-01**
- (52) **U.S. Cl.** **D21/565**
- (58) **Field of Classification Search** D21/484,
D21/490, 493, 564, 565, 802, 818, 821;
446/168–174, 84, 89, 108, 112, 114, 116,
446/124–128, 429, 444–447; 463/58–69;
238/10 R, 10 A–10 C, 10 E, 10 F; 104/60,
104/69

See application file for complete search history.

(56) **References Cited**

U.S. PATENT DOCUMENTS

1,576,192	A *	3/1926	Jennings	238/10 R
2,543,460	A *	2/1951	Larrabee	238/10 E
3,464,624	A	9/1969	Christiansen		
3,480,210	A *	11/1969	Perrinjaquet	238/10 R
3,583,631	A	6/1971	Christiansen		
D222,493	S *	10/1971	Douglas et al.	D21/565
D250,056	S *	10/1978	Heim	D21/565
D261,292	S	10/1981	Tong		
4,403,733	A	9/1983	Bach et al.		
D281,002	S	10/1985	Olsen		
D281,443	S	11/1985	Olsen		
D296,803	S	7/1988	Bach et al.		
D296,804	S	7/1988	Bach et al.		
D296,805	S	7/1988	Mikkelsen		
D296,806	S	7/1988	Bach et al.		
D297,851	S *	9/1988	Schroll	D21/565
4,861,306	A	8/1989	Bolli et al.		
D314,996	S	2/1991	Olsen		
5,087,001	A	2/1992	Bolli et al.		

D325,057	S	3/1992	Plagborg		
D326,296	S *	5/1992	Hillman	D21/565
D326,880	S	6/1992	Larsen		
D332,642	S	1/1993	Pagel		
D344,306	S	2/1994	Ruszkai		
D344,307	S	2/1994	Ruszkai		
D344,308	S	2/1994	Ruszkai		
D344,309	S	2/1994	Ruszkai		
D344,310	S	2/1994	Ruszkai		
D344,554	S	2/1994	Ruszkai		
D344,555	S	2/1994	Ruszkai		
D344,992	S	3/1994	Rasz kai		
D349,528	S *	8/1994	Ruszkai	D13/158
D357,714	S	4/1995	Ryaa		
5,657,695	A	8/1997	Lanoix et al.		
D388,138	S	12/1997	Lanoix et al.		
5,779,145	A *	7/1998	Zelle et al.	238/10 E
D409,690	S	5/1999	Nielsen		
D409,691	S	5/1999	Harms		
D412,949	S	8/1999	Nielsen		
6,616,500	B1	9/2003	Harms et al.		

* cited by examiner

Primary Examiner — Cynthia M Chin

(74) *Attorney, Agent, or Firm* — Plumsea Law Group, LLC

(57) **CLAIM**

We claim the ornamental design for a toy vehicle track link, as shown and described.

DESCRIPTION

FIG. 1 is a top perspective view of the toy vehicle track link; FIG. 2 is a front elevational view thereof; FIG. 3 is a rear elevational view thereof; FIG. 4 is a left side elevational view thereof; FIG. 5 is a right side elevational view thereof; FIG. 6 is a top plan view thereof; and, FIG. 7 is a bottom plan view thereof.

The broken or dashed lines included in the figures depict portions of the article that form no part of the claim. The shading illustrated in the figures is provided merely to represent the contour of the design and is not intended to be illustrative of the texture, gloss, or surface decoration.

1 Claim, 2 Drawing Sheets

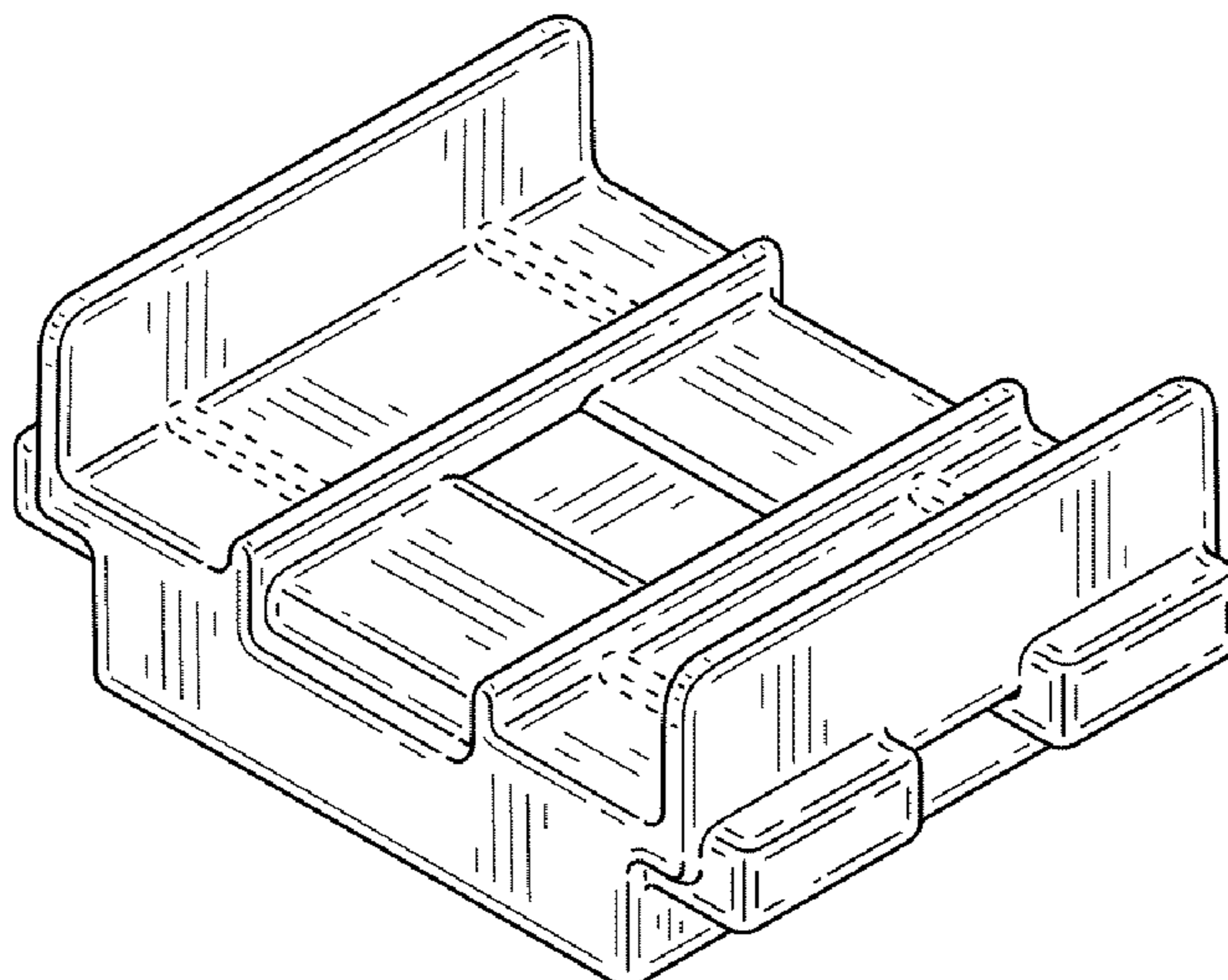

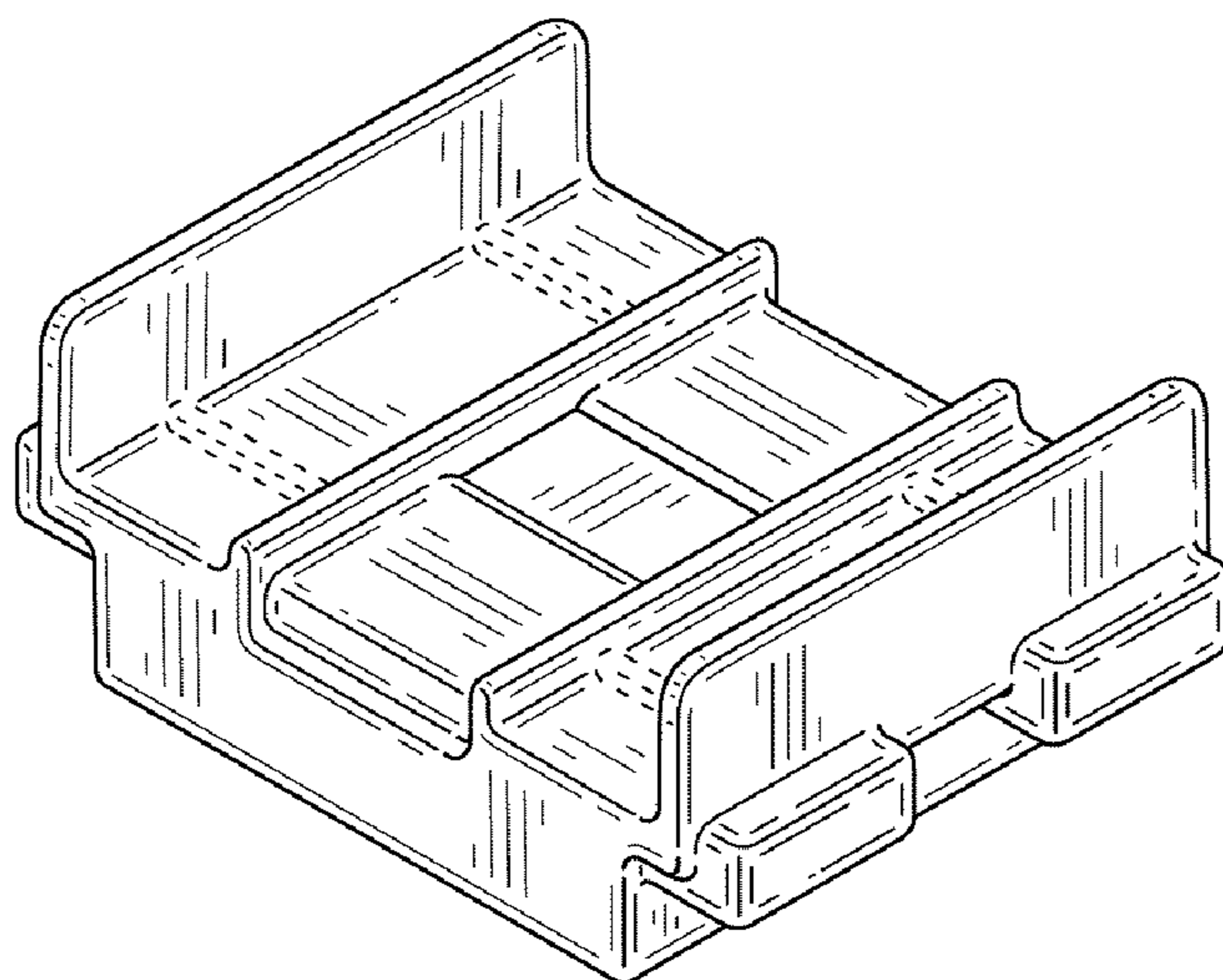

Fig. 1

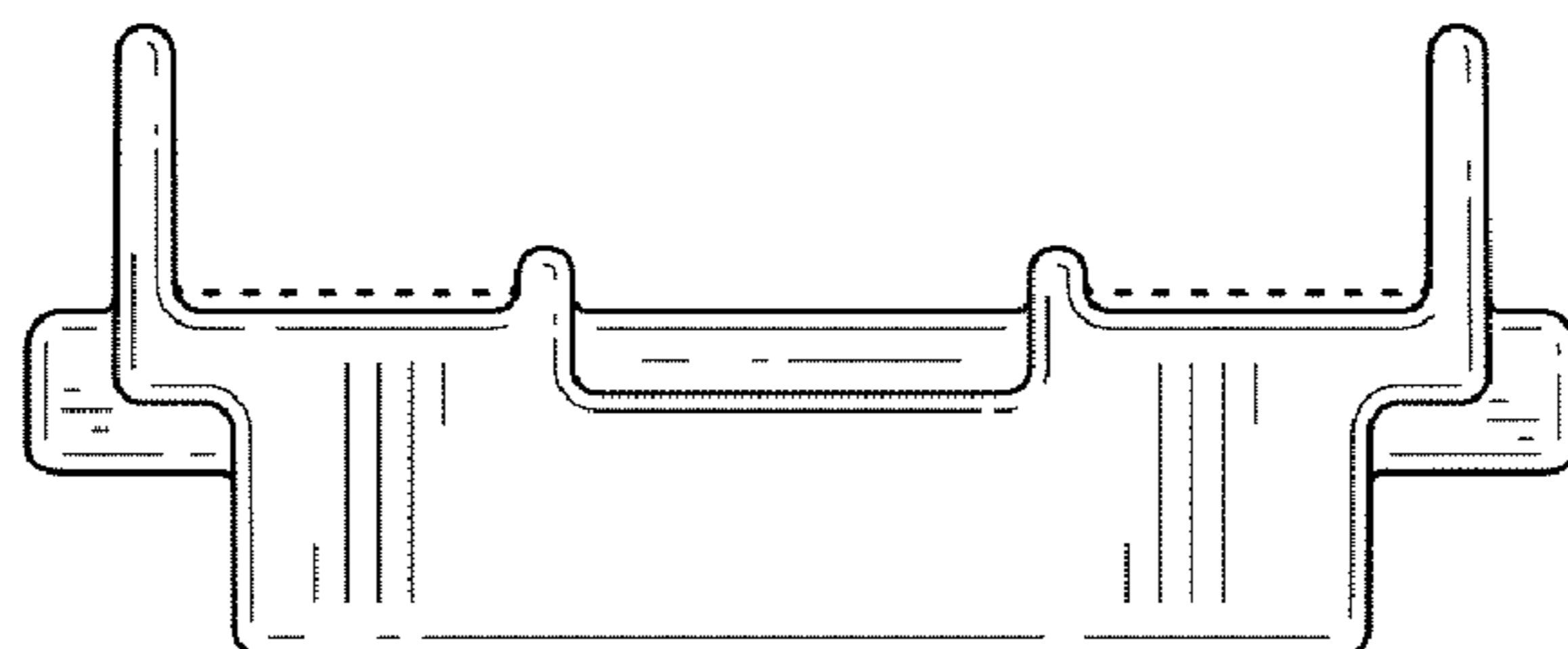

Fig. 2

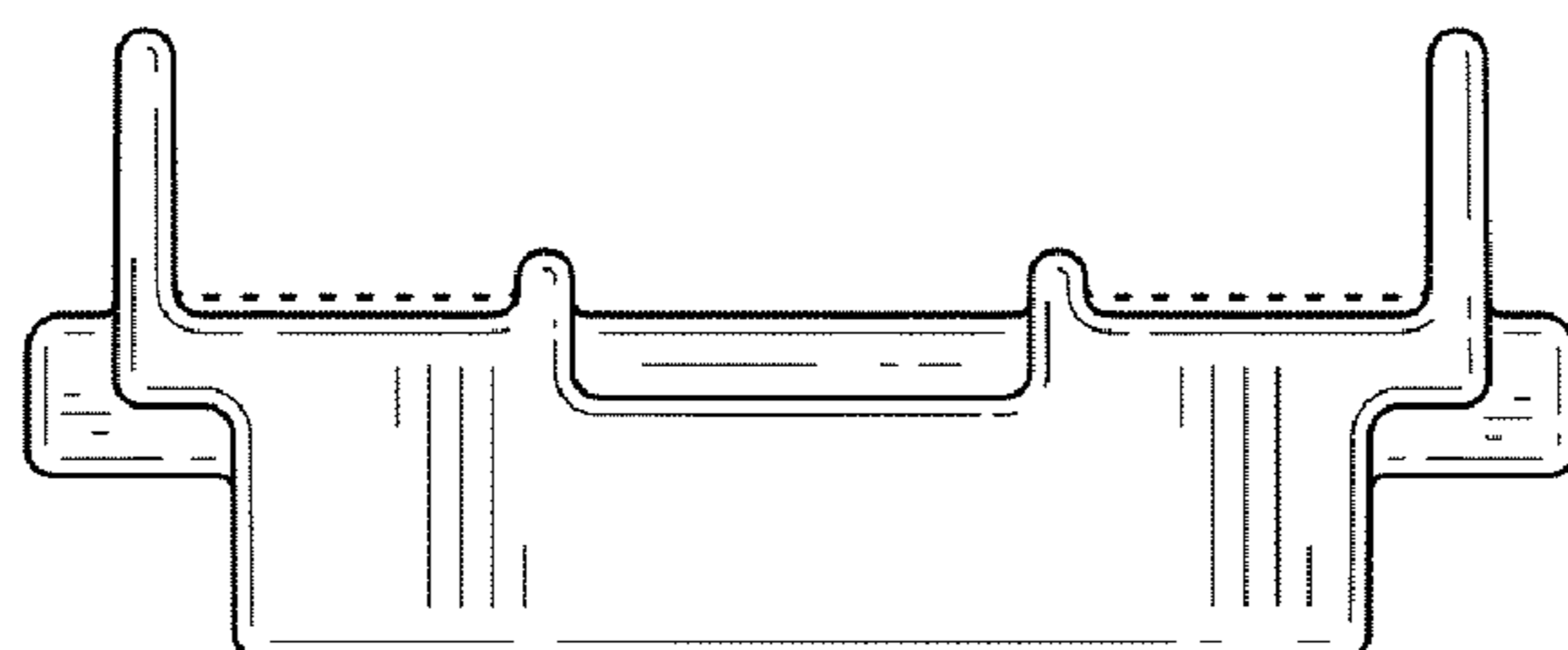

Fig. 3

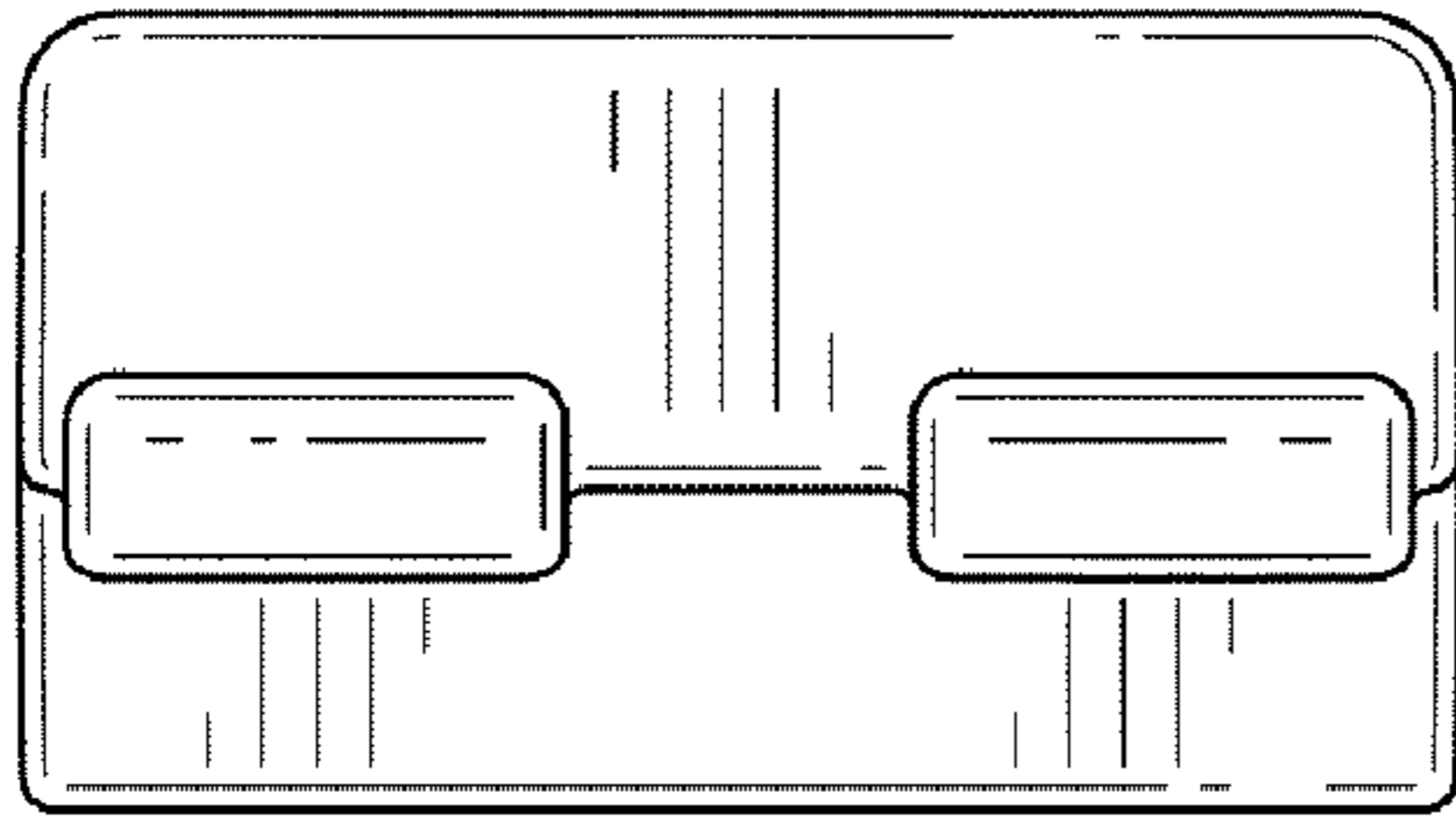

Fig. 4

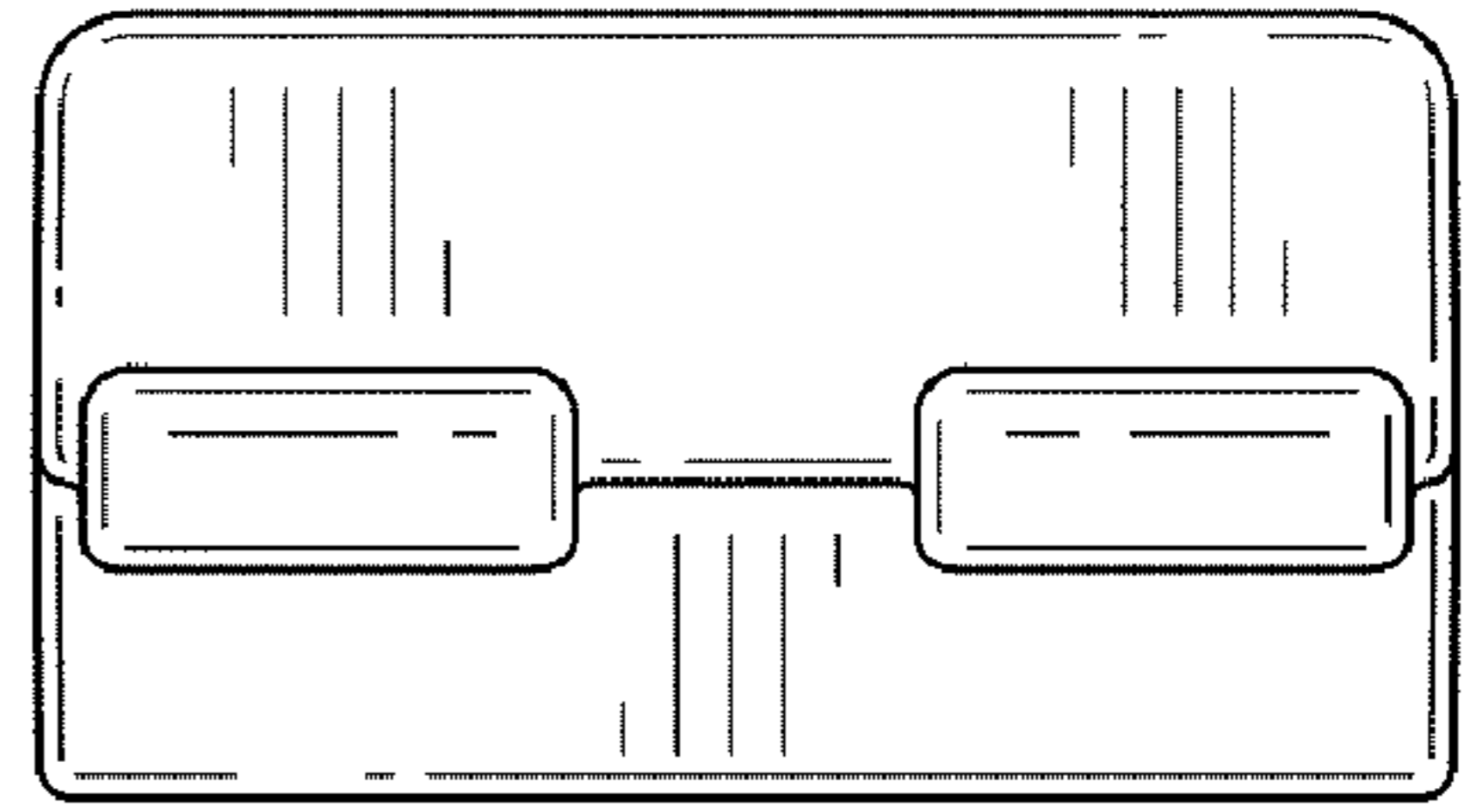

Fig. 5

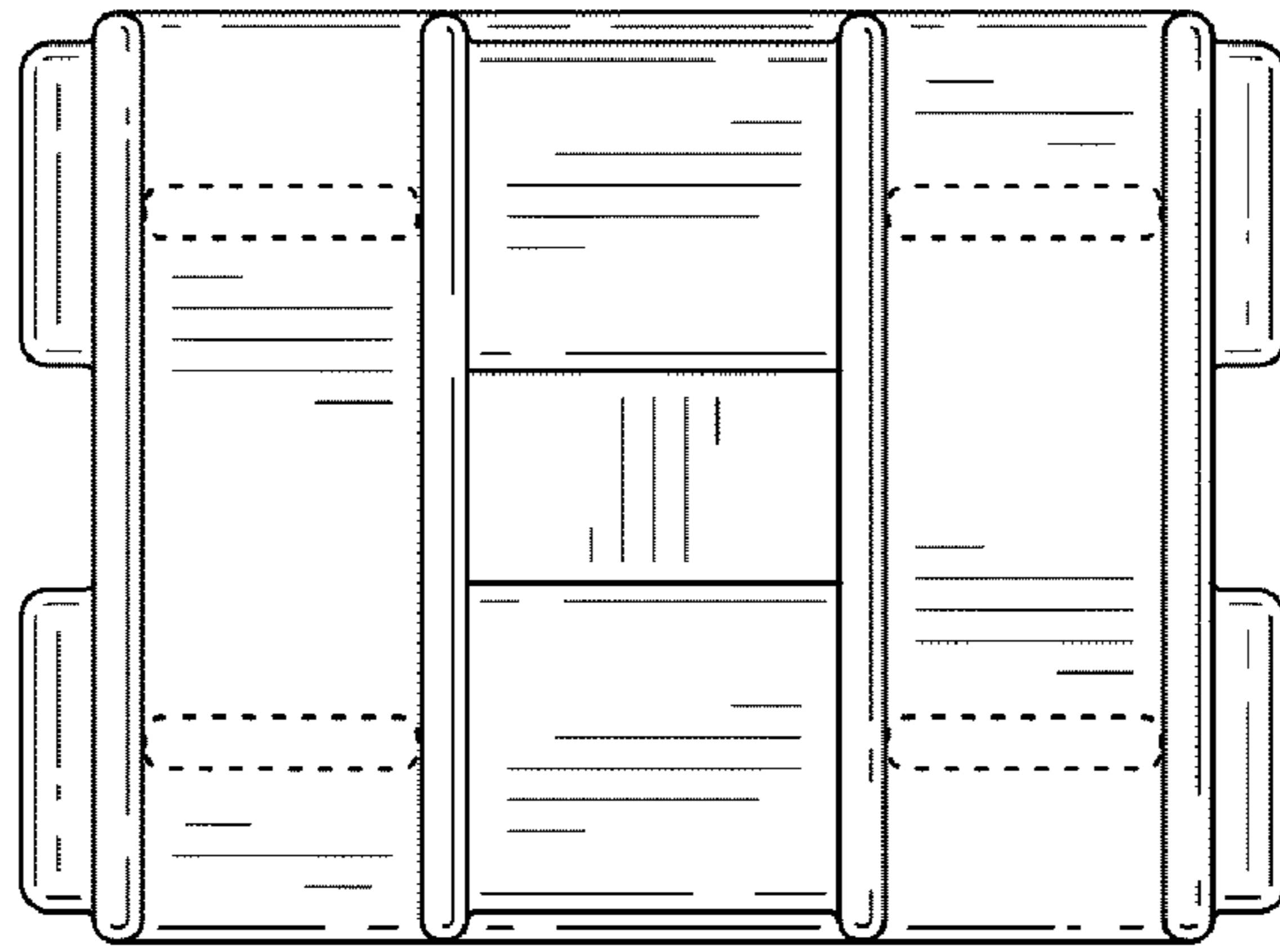

Fig. 6

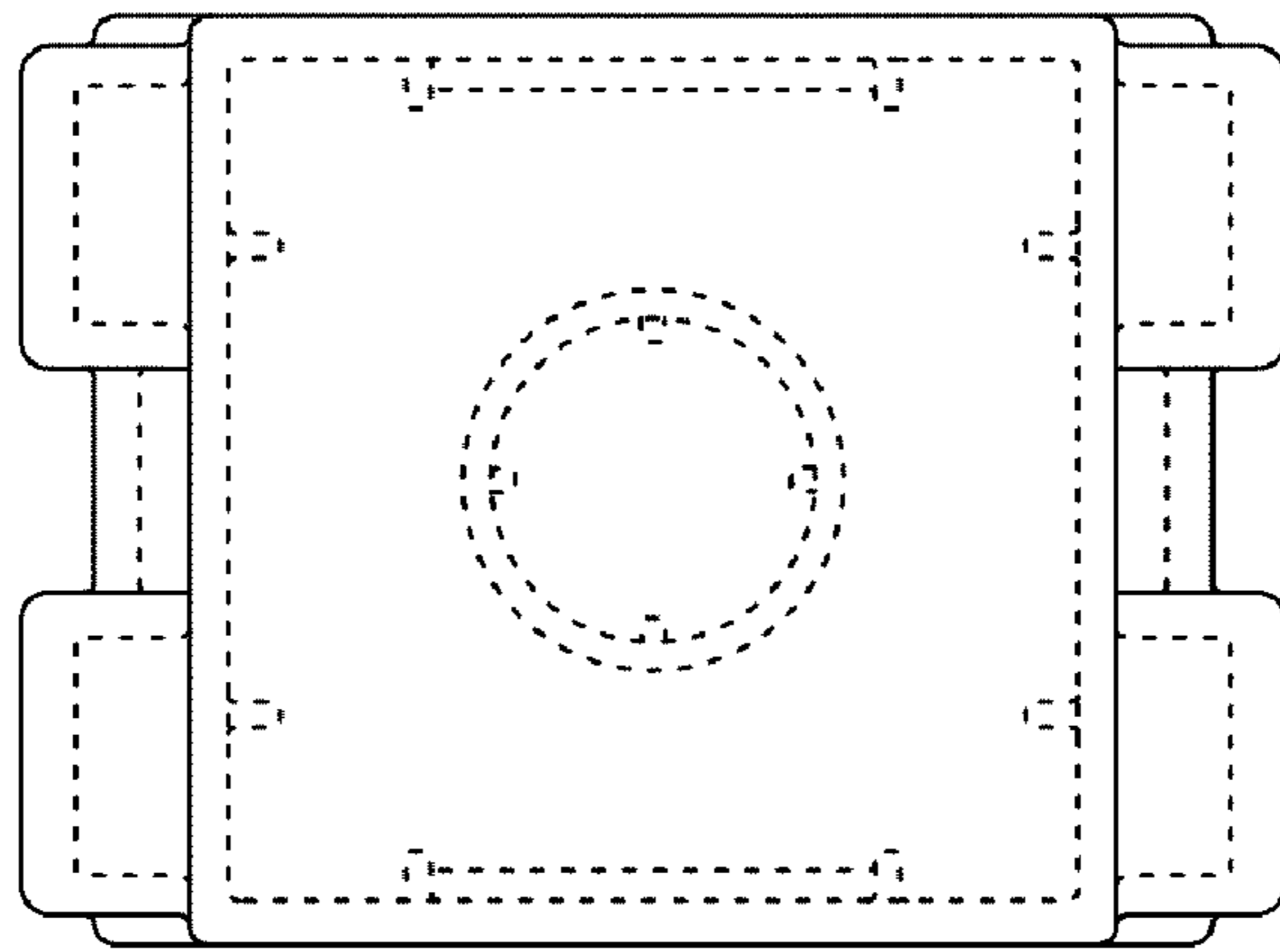

Fig. 7