



US00D645884S

(12) **United States Design Patent**
Attwood et al.

(10) **Patent No.:** **US D645,884 S**

(45) **Date of Patent:** **** Sep. 27, 2011**

(54) **LINK FOR A DRAGLINE ASSEMBLY**

(75) Inventors: **Reece Attwood**, Mayfield West (AU);
Joel Nelio Martinelli, Merewether (AU)

(73) Assignee: **Bradken Resources Pty Limited**,
Mayfield West, NSW (AU)

(**) Term: **14 Years**

(21) Appl. No.: **29/382,092**

(22) Filed: **Dec. 29, 2010**

(30) **Foreign Application Priority Data**

Jun. 29, 2010 (AU) 12664/2010

(51) **LOC (9) Cl.** **15-03**

(52) **U.S. Cl.** **D15/21; D15/28**

(58) **Field of Classification Search** D15/21,
D15/28, 138; 37/397, 398, 394, 395, 396,
37/399, 401, 457, 453; 16/2.4; 403/151,
403/154, 155, 156, 316-319, 327, 349.2,
403/359.5; 59/86

See application file for complete search history.

(56) **References Cited**

U.S. PATENT DOCUMENTS

4,060,978 A * 12/1977 McBain et al. 59/78
4,134,255 A * 1/1979 McBain et al. 59/78

5,343,641	A *	9/1994	Gregory	37/397
5,367,798	A *	11/1994	Hughes	37/399
5,865,557	A *	2/1999	Kasim	403/79
5,966,849	A *	10/1999	Moehnke et al.	37/457
5,992,061	A *	11/1999	Fleck et al.	37/397
D435,565	S *	12/2000	Barani	D15/28
6,170,248	B1 *	1/2001	Ianello et al.	59/78
6,209,234	B1 *	4/2001	Meyers	37/398
6,871,486	B2 *	3/2005	Moehnke et al.	59/78
2003/0213226	A1 *	11/2003	Moehnke et al.	59/78
2004/0060203	A1 *	4/2004	Briscoe	37/307
2004/0139719	A1 *	7/2004	Moehnke et al.	59/78
2009/0136291	A1 *	5/2009	McClanahan et al.	403/156
2009/0139118	A1 *	6/2009	Lunn	37/398

* cited by examiner

Primary Examiner — Mark Goodwin

(74) *Attorney, Agent, or Firm* — McDermott Will & Emery
LLP

(57) **CLAIM**

The ornamental design for a link for a dragline assembly, as shown and described.

DESCRIPTION

FIG. 1 is a front perspective view of the link for a dragline assembly, illustrating the new design;

FIG. 2 is a top view of the link for a dragline assembly;

FIG. 3 is a rear view of the link for a dragline assembly;

FIG. 4 is a side view of the link for a dragline assembly;

FIG. 5 is a front view of the link for a dragline assembly; and,

FIG. 6 is a bottom view of the link for a dragline assembly.

1 Claim, 3 Drawing Sheets

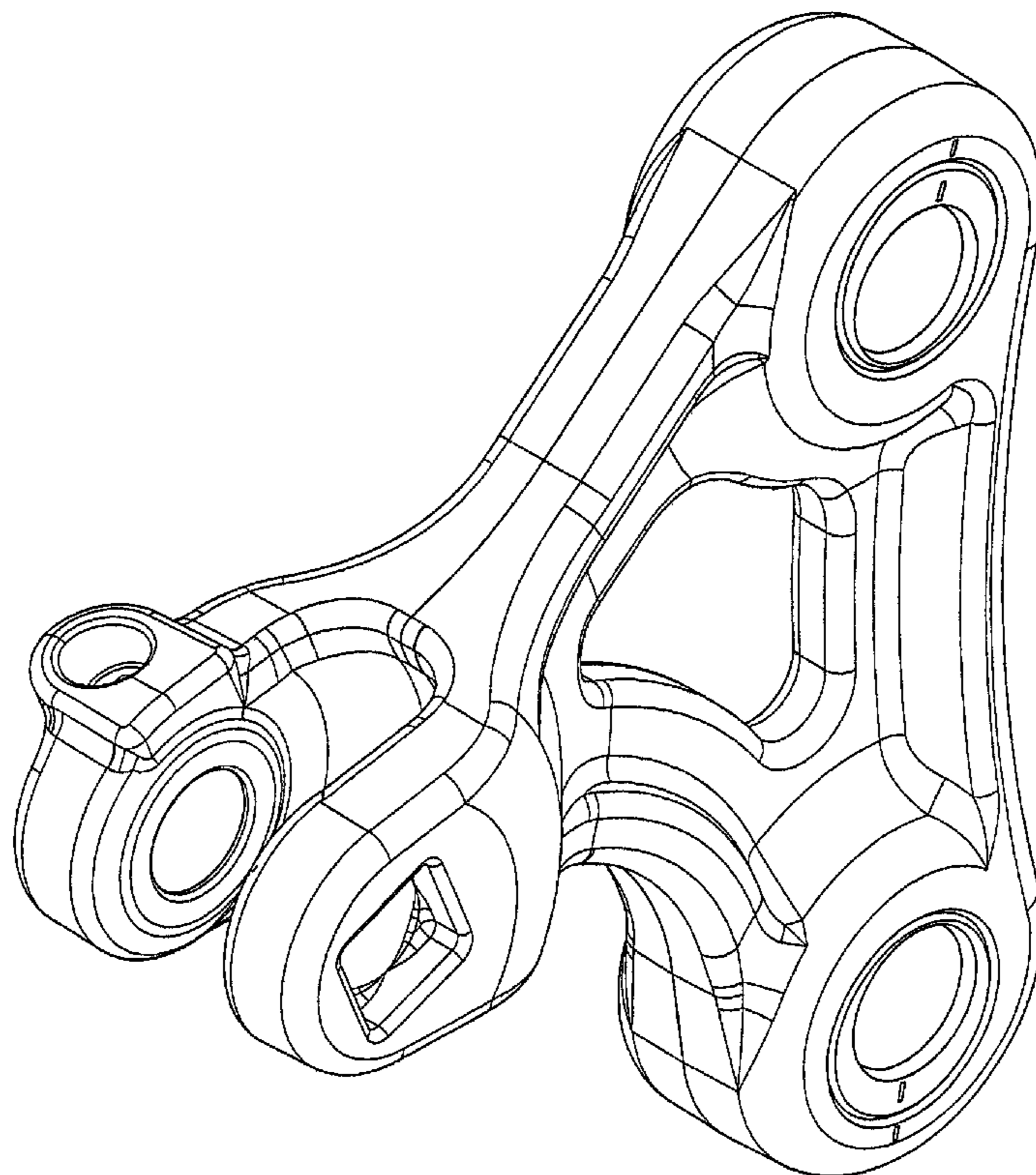

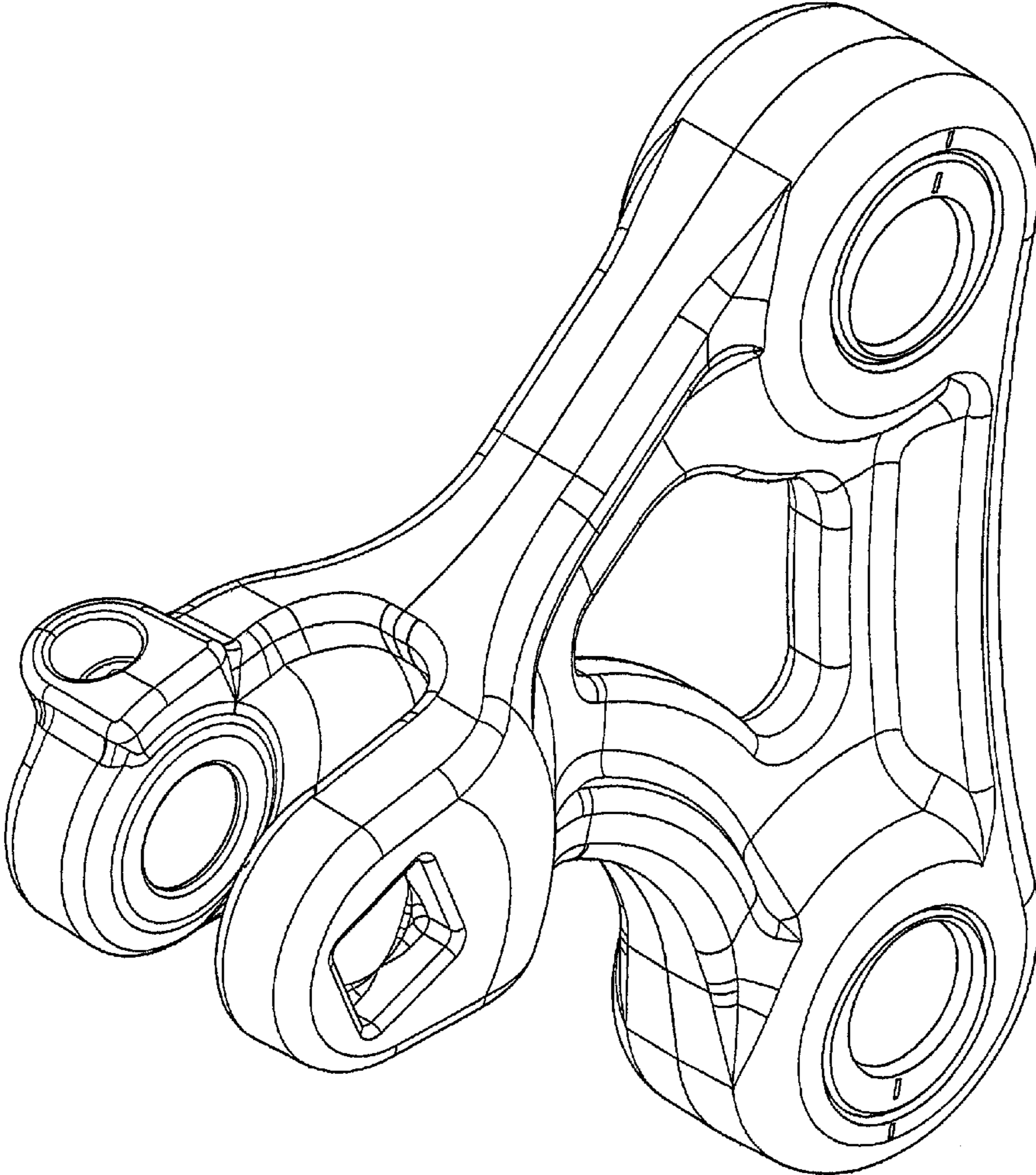

FIG. 1

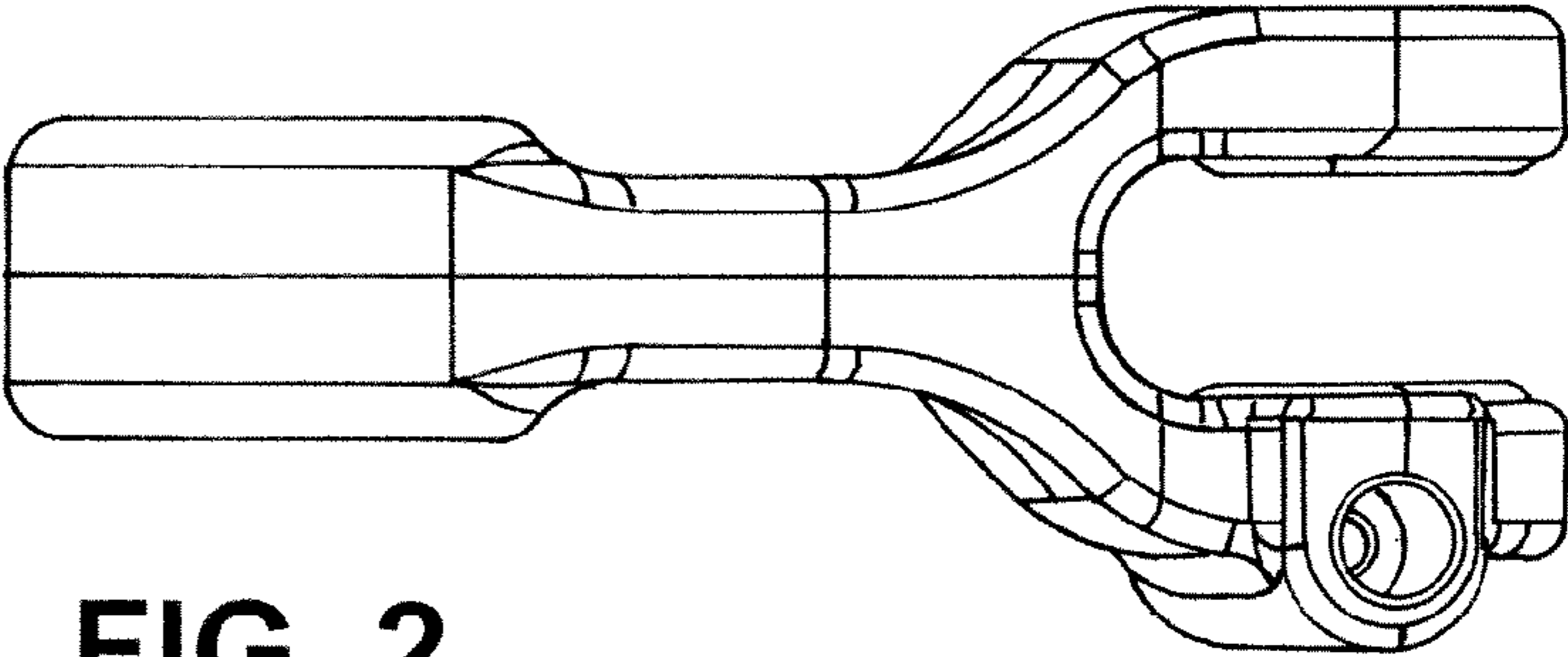

FIG. 2

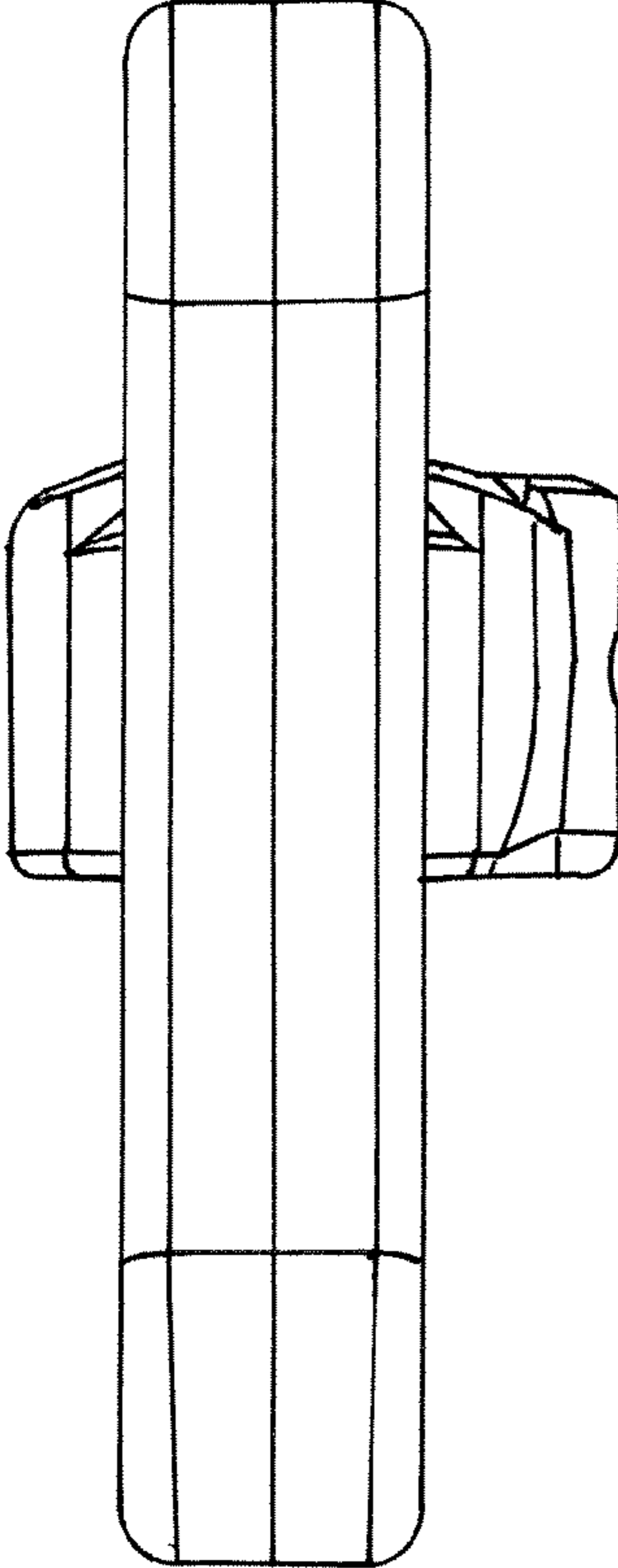

FIG. 3

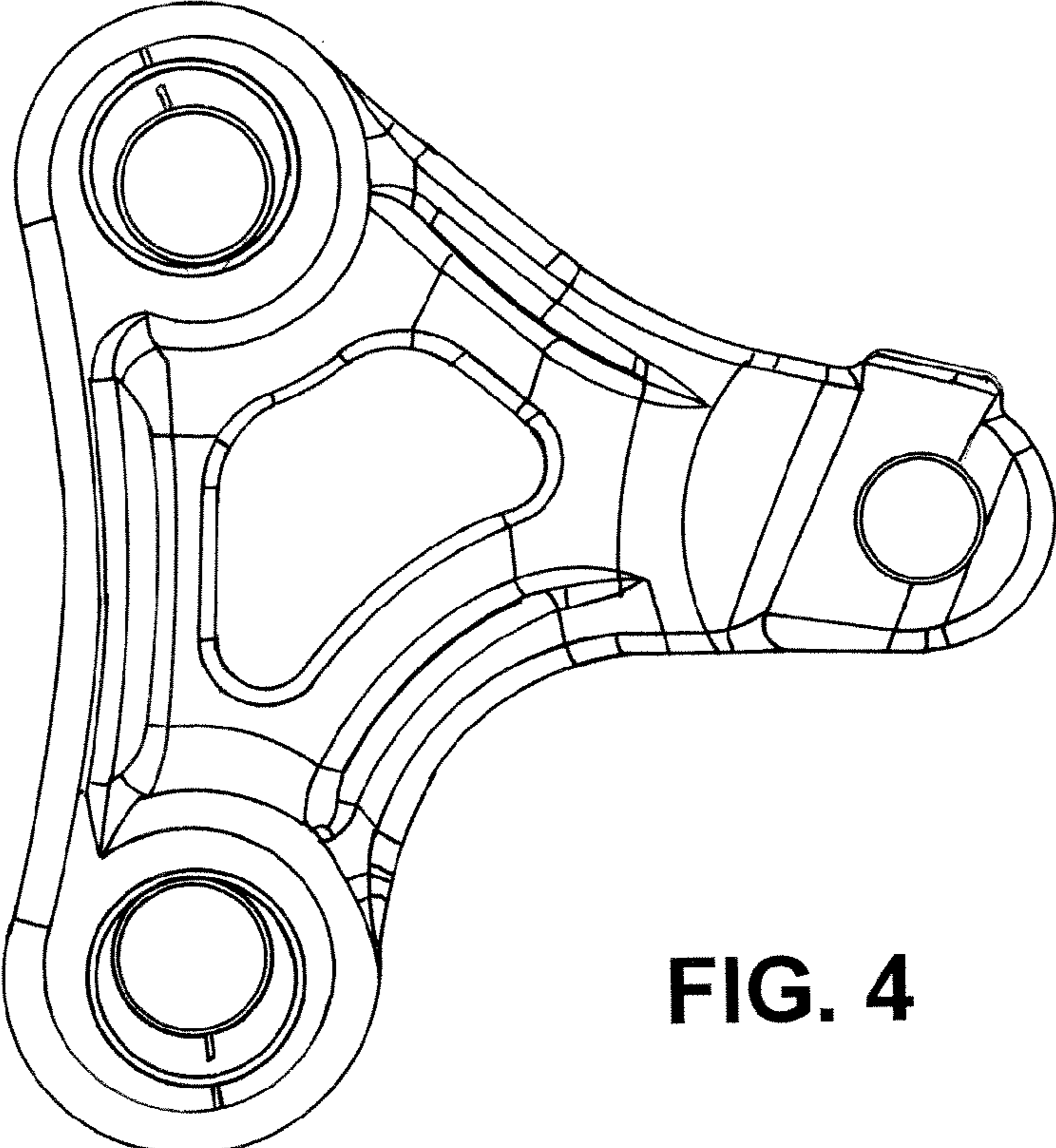

FIG. 4

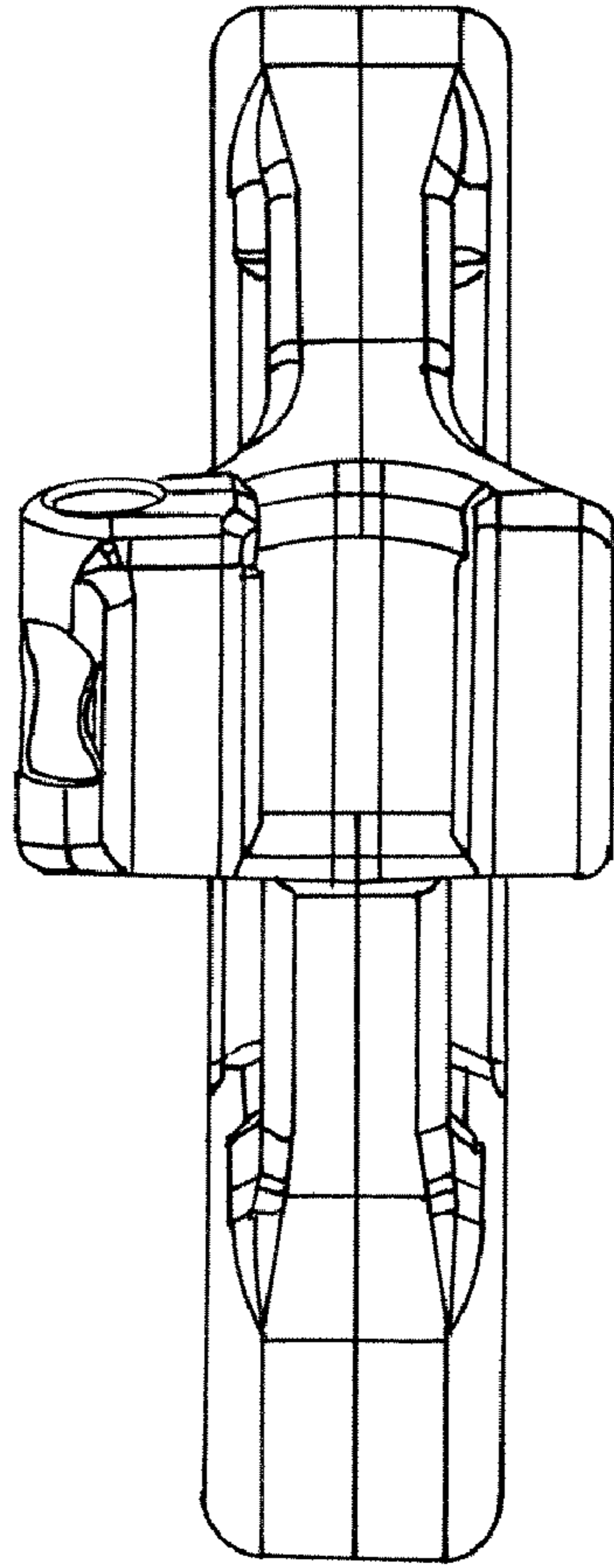

FIG. 5

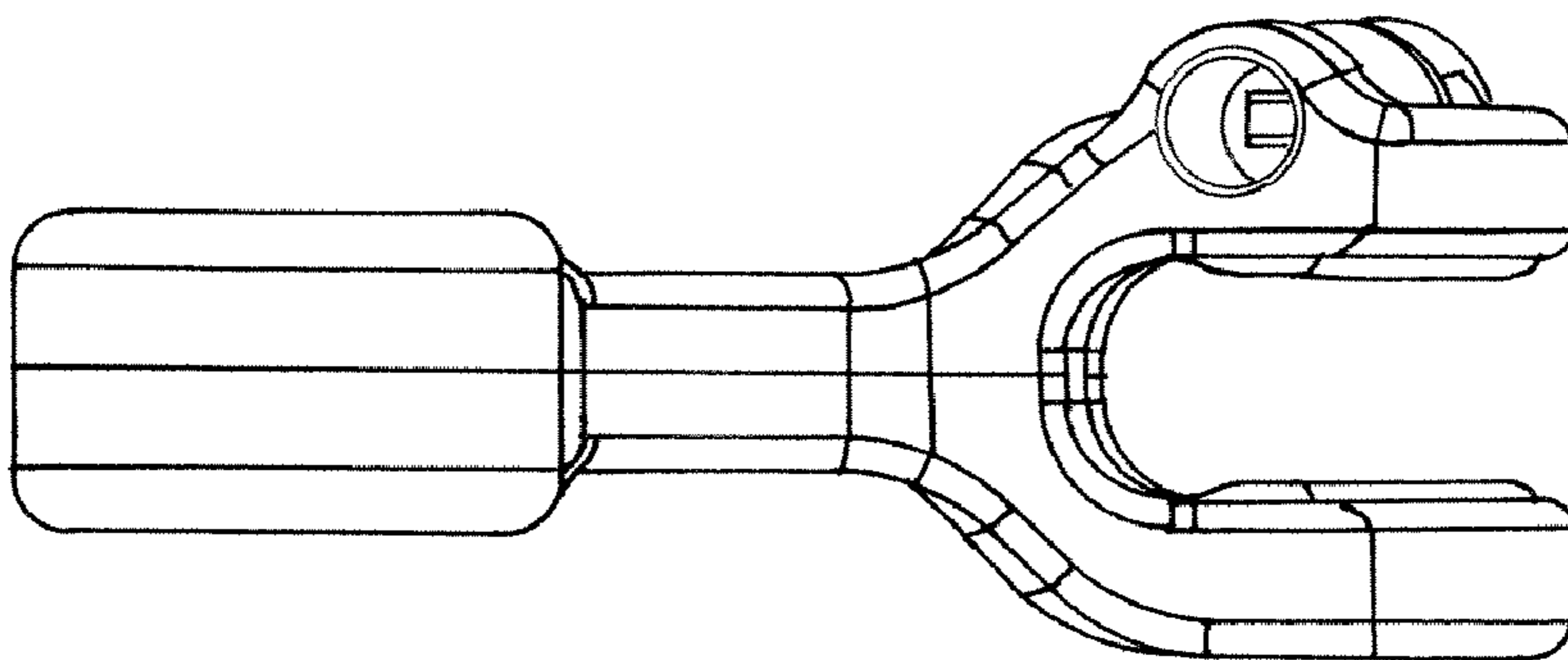

FIG. 6