



US00D645823S

(12) **United States Design Patent**
Dillon

(10) **Patent No.:** **US D645,823 S**

(45) **Date of Patent:** **** Sep. 27, 2011**

(54) **GROUNDING PORT CONNECTOR WITH THROUGH HOLE**

(76) Inventor: **Eddie P. Dillon**, Phoenix, AZ (US)

(**) Term: **14 Years**

(21) Appl. No.: **29/367,306**

(22) Filed: **Aug. 5, 2010**

(51) **LOC (9) Cl.** **13-03**

(52) **U.S. Cl.** **D13/147**

(58) **Field of Classification Search** D13/133,
D13/147, 154, 184, 199; 439/374, 378, 379,
439/380, 527, 533, 540.1, 607.01, 607.04,
439/607.07, 607.08, 607.09, 607.11, 607.13,
439/607.14, 607.25, 607.31, 607.32, 607.36,
439/607.4, 607.46, 660, 680, 892
See application file for complete search history.

(56) **References Cited**

U.S. PATENT DOCUMENTS

D235,552 S *	6/1975	Derr et al.	D13/146
3,945,711 A	3/1976	Hohorst et al.		
D308,511 S *	6/1990	Makita et al.	D13/146
D319,625 S *	9/1991	Nagasaka et al.	D13/146
D326,084 S *	5/1992	Nagasaka et al.	D13/147

D344,714 S	3/1994	Kulbersh		
6,132,238 A	10/2000	Hartmann et al.		
6,364,698 B1	4/2002	Tsai		
D508,677 S *	8/2005	Chau et al.	D13/146
7,384,319 B2	6/2008	Kirstein et al.		
7,507,106 B2	3/2009	Keswani et al.		
D597,958 S *	8/2009	Sakamoto	D13/147
D630,585 S *	1/2011	Sakamoto	D13/147

* cited by examiner

Primary Examiner — Daniel Bui

(57) **CLAIM**

The ornamental design for a grounding port connector with through hole, as shown and described.

DESCRIPTION

FIG. 1 is a perspective view of a grounding port connector with through hole showing my new design; FIG. 2 is a front view thereof; FIG. 3 is a back view thereof; FIG. 4 is a side elevation view thereof, the opposite side elevation view is a mirror image thereto; and, FIG. 5 is a top plan view thereof, the bottom plan view is a mirror image thereto. The broken lines shown in FIG. 1 are included for the purpose of illustrating environment and form no part of the claim.

1 Claim, 3 Drawing Sheets

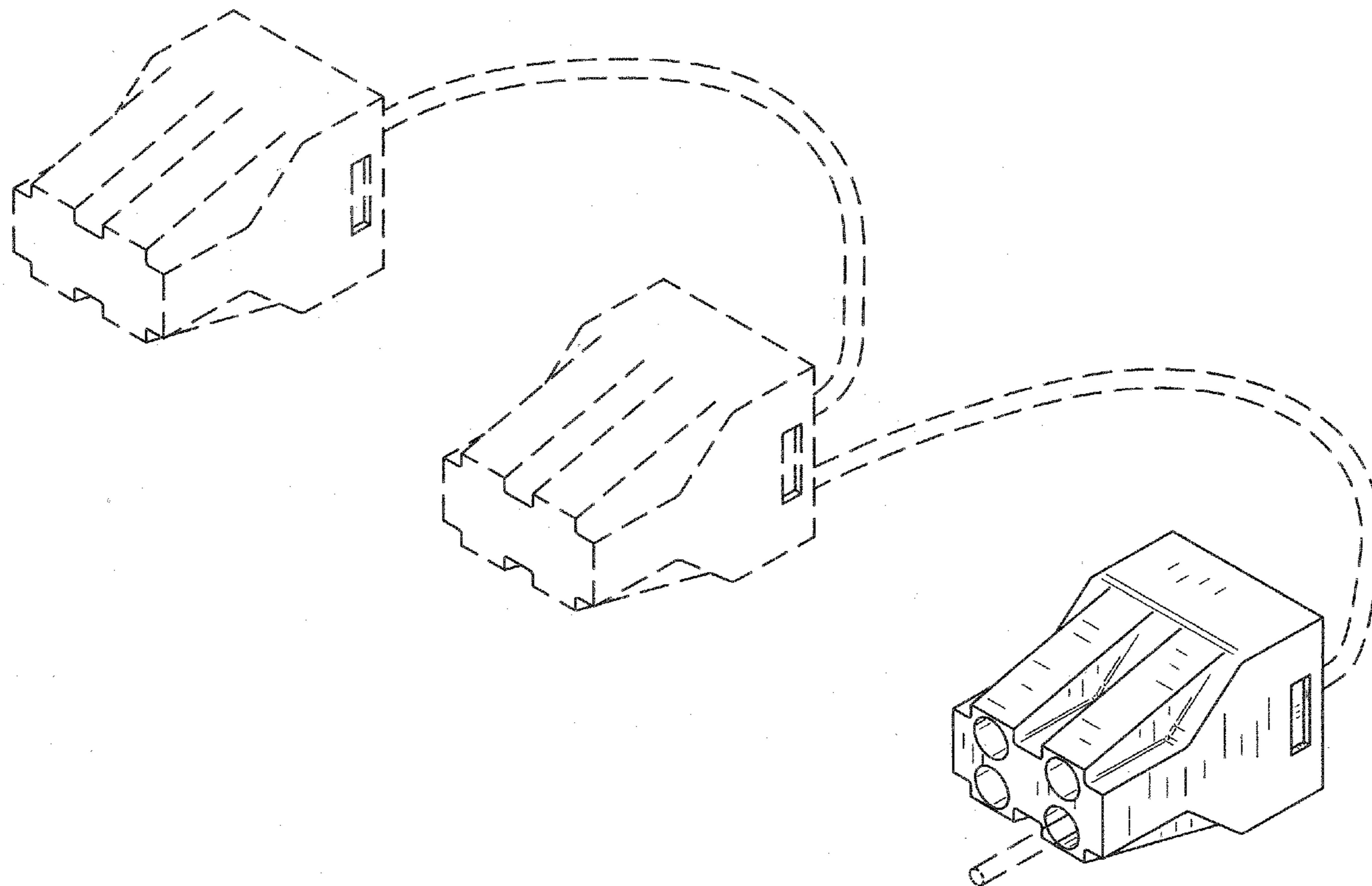

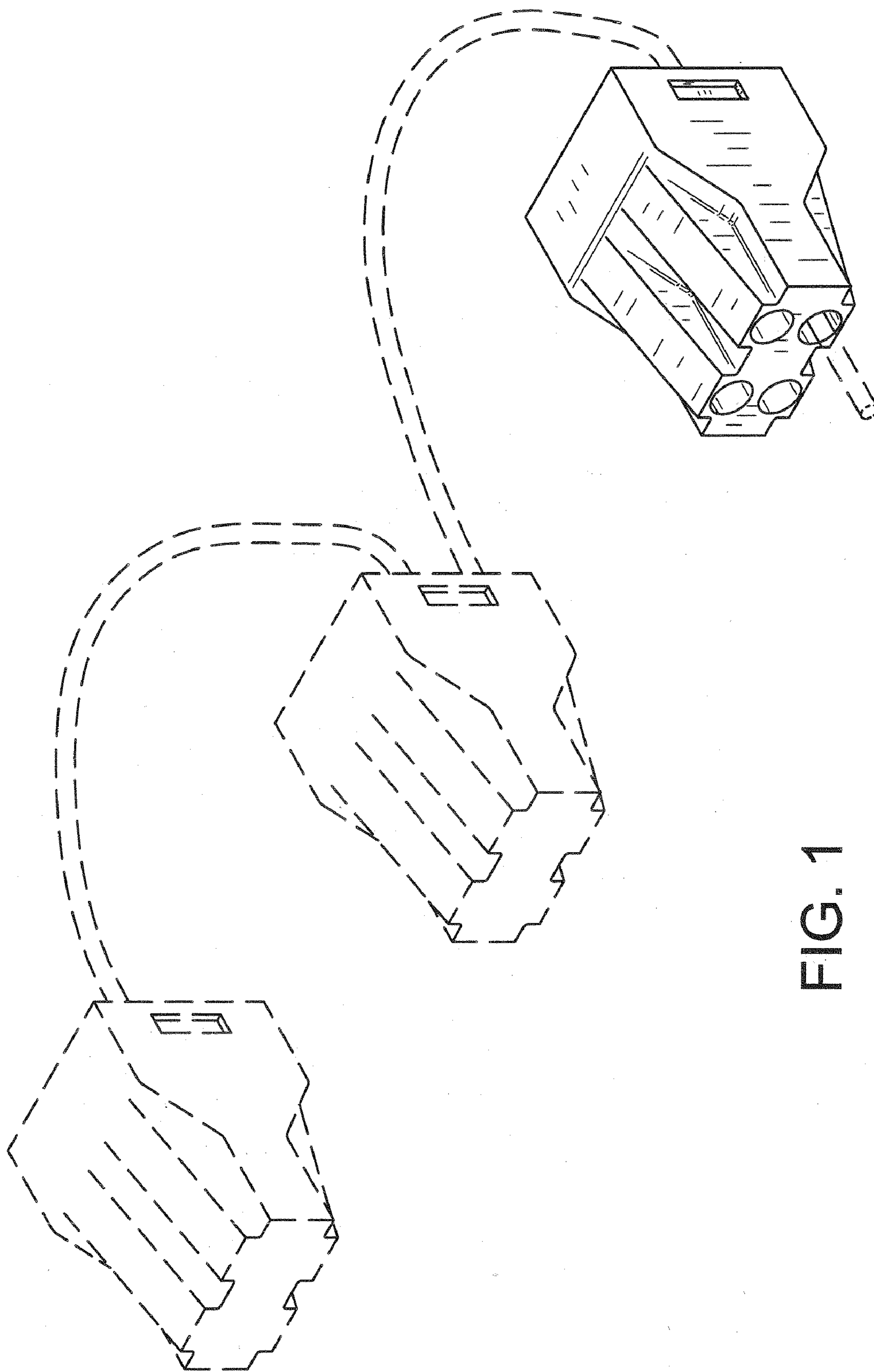

FIG. 1

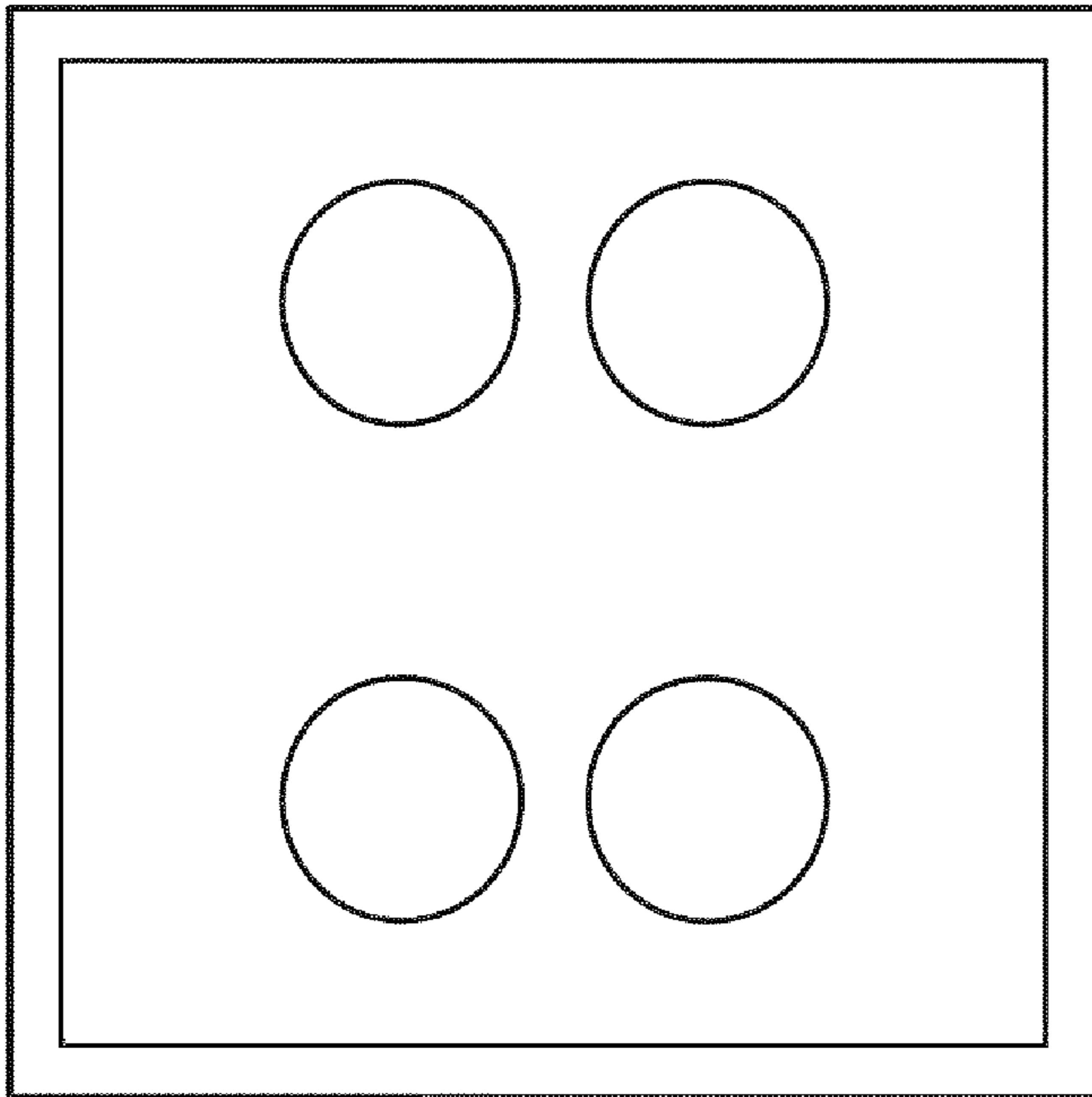

FIG. 3

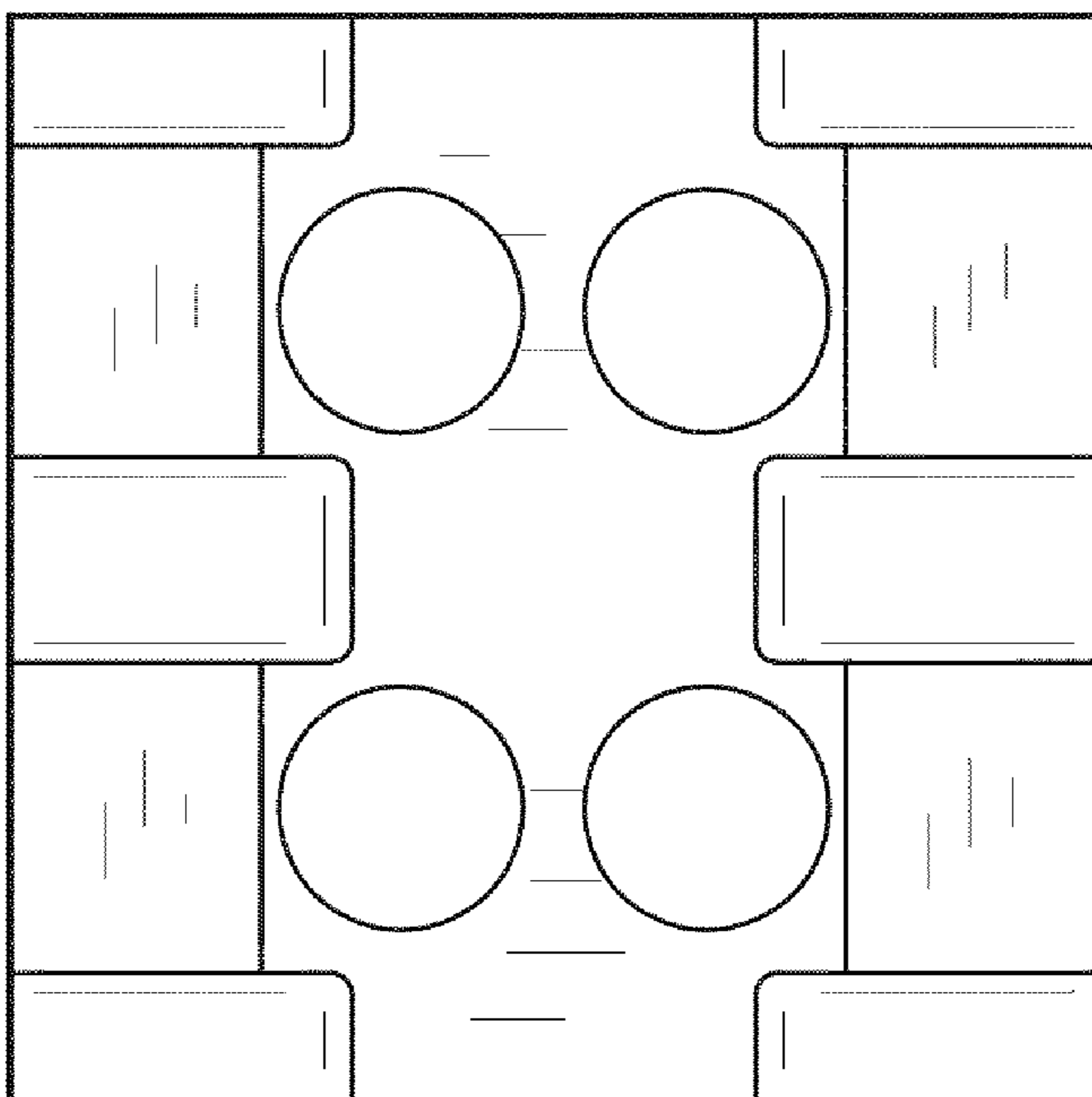

FIG. 2

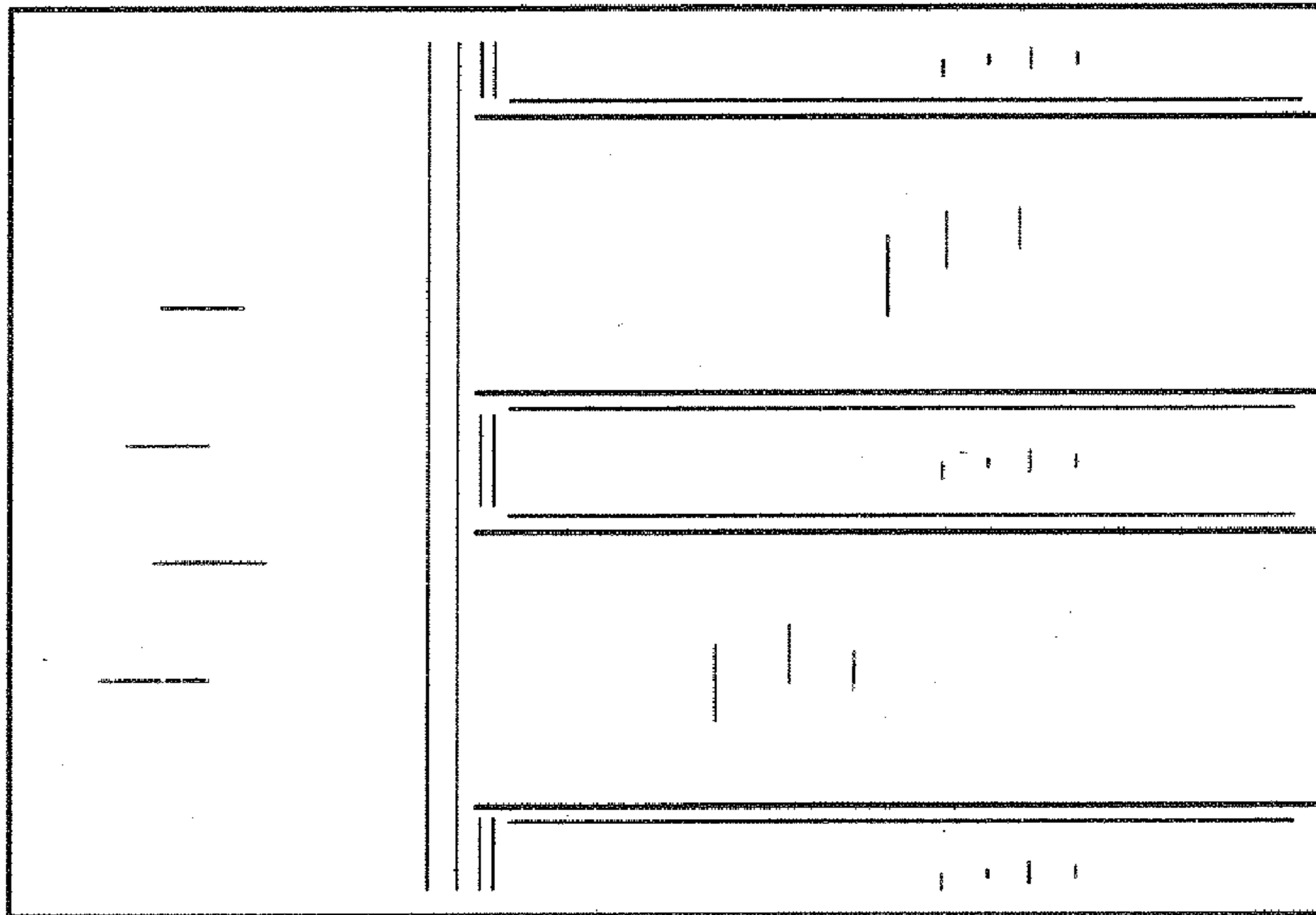

FIG. 4

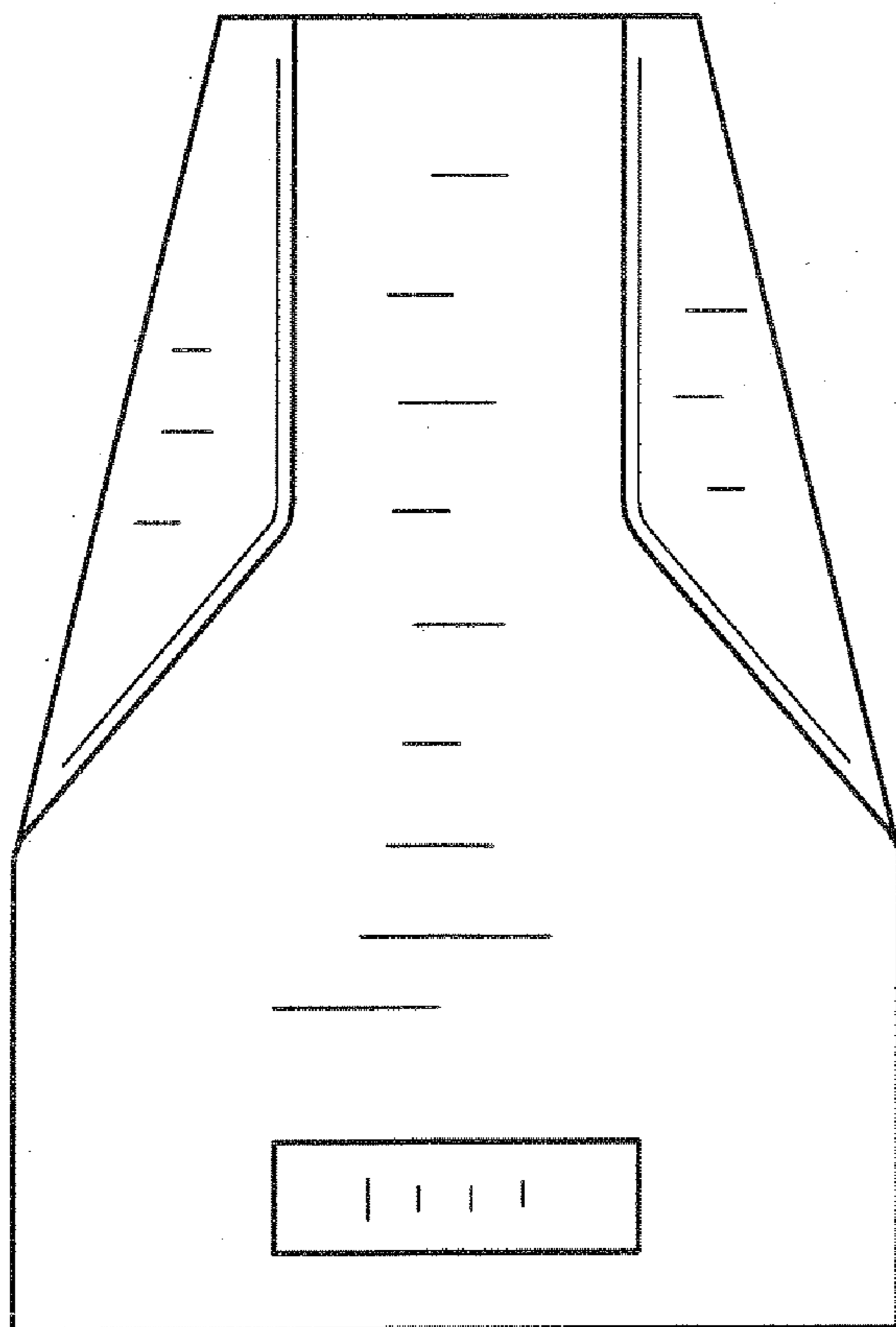

FIG. 5