



US00D645661S

(12) **United States Design Patent**
Marsh

(10) **Patent No.:** **US D645,661 S**

(45) **Date of Patent:** **** Sep. 27, 2011**

(54) **TRUCK AND TRAILER CONTAINER**

(75) Inventor: **Ian Marsh**, Mosgiel (NZ)

(73) Assignee: **Rinnon Products Lintied**, Dunedin (NZ)

(**) Term: **14 Years**

(21) Appl. No.: **29/341,678**

(22) Filed: **Aug. 11, 2009**

(51) **LOC (9) Cl.** **03-01**

(52) **U.S. Cl.** **D3/272**

(58) **Field of Classification Search** D3/201,
D3/272, 273, 276, 304; D6/430-435, 440,
D6/443, 449, 559; 206/386, 599, 600, 503;
312/902

See application file for complete search history.

(56) **References Cited**

U.S. PATENT DOCUMENTS

| | | | | | | |
|--------------|----|---|---------|----------------|-------|---------|
| D221,522 | S | * | 8/1971 | Meller et al. | | D3/272 |
| D363,162 | S | * | 10/1995 | Bunger | | D3/272 |
| D370,780 | S | * | 6/1996 | Bunger | | D3/272 |
| 5,642,827 | A | * | 7/1997 | Madsen | | 220/1.5 |
| D403,153 | S | * | 12/1998 | Martineau | | D3/272 |
| D426,382 | S | * | 6/2000 | Martineau | | D3/272 |
| D580,653 | S | * | 11/2008 | Robaina | | D3/272 |
| D599,548 | S | * | 9/2009 | Bech | | D3/272 |
| 7,731,459 | B2 | * | 6/2010 | Bell | | 410/68 |
| 2008/0179319 | A1 | * | 7/2008 | Nielsen et al. | | 220/1.5 |

2010/0147728 A1* 6/2010 Guiles et al. 206/521
* cited by examiner

Primary Examiner — Prabhakar Deshmukh

(74) *Attorney, Agent, or Firm* — Greer, Burns & Crain, Ltd.

(57) **CLAIM**

The ornamental design for a truck and trailer container, as shown and described.

DESCRIPTION

FIG. 1 is a perspective view of a truck and trailer container showing my new design;

FIG. 2 is a front elevational view thereof;

FIG. 3 is a rear elevational view thereof;

FIG. 4 is an enlarged fragmentary perspective view of the front thereof;

FIG. 5 is a side elevational view thereof;

FIG. 6 is an enlarged fragmentary sectional view taken at portion 6 of FIG. 1,

FIG. 7 is an enlarged fragmentary sectional view taken along line 7-7 of FIG. 1;

FIG. 8 is an enlarged fragmentary sectional view taken along line 8-8 of FIG. 1; and,

FIG. 9 is an enlarged fragmentary sectional view taken along line 9-9 of FIG. 1.

The broken lines are for illustrative purpose only and form no part of the claimed design.

1 Claim, 3 Drawing Sheets

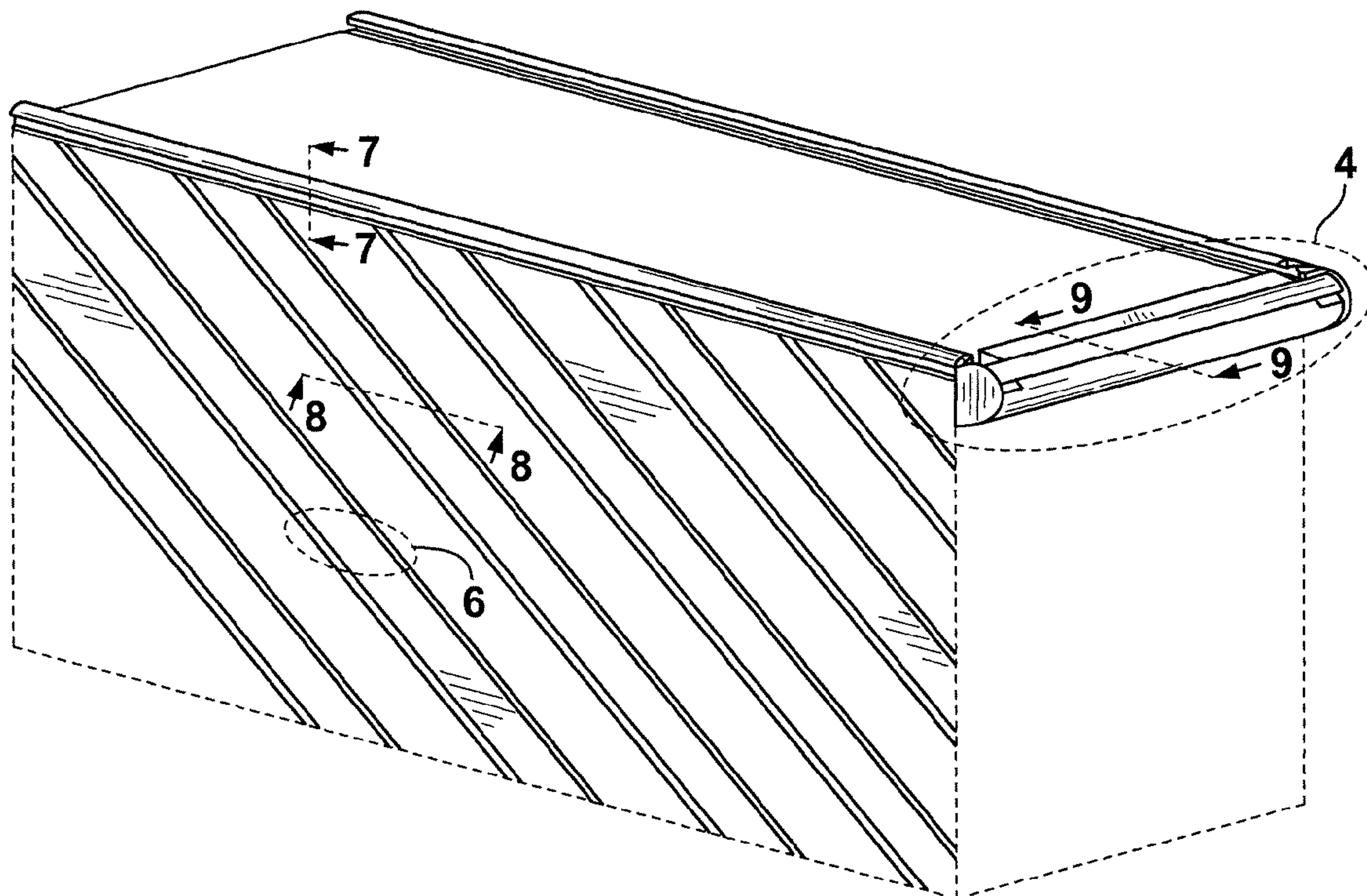

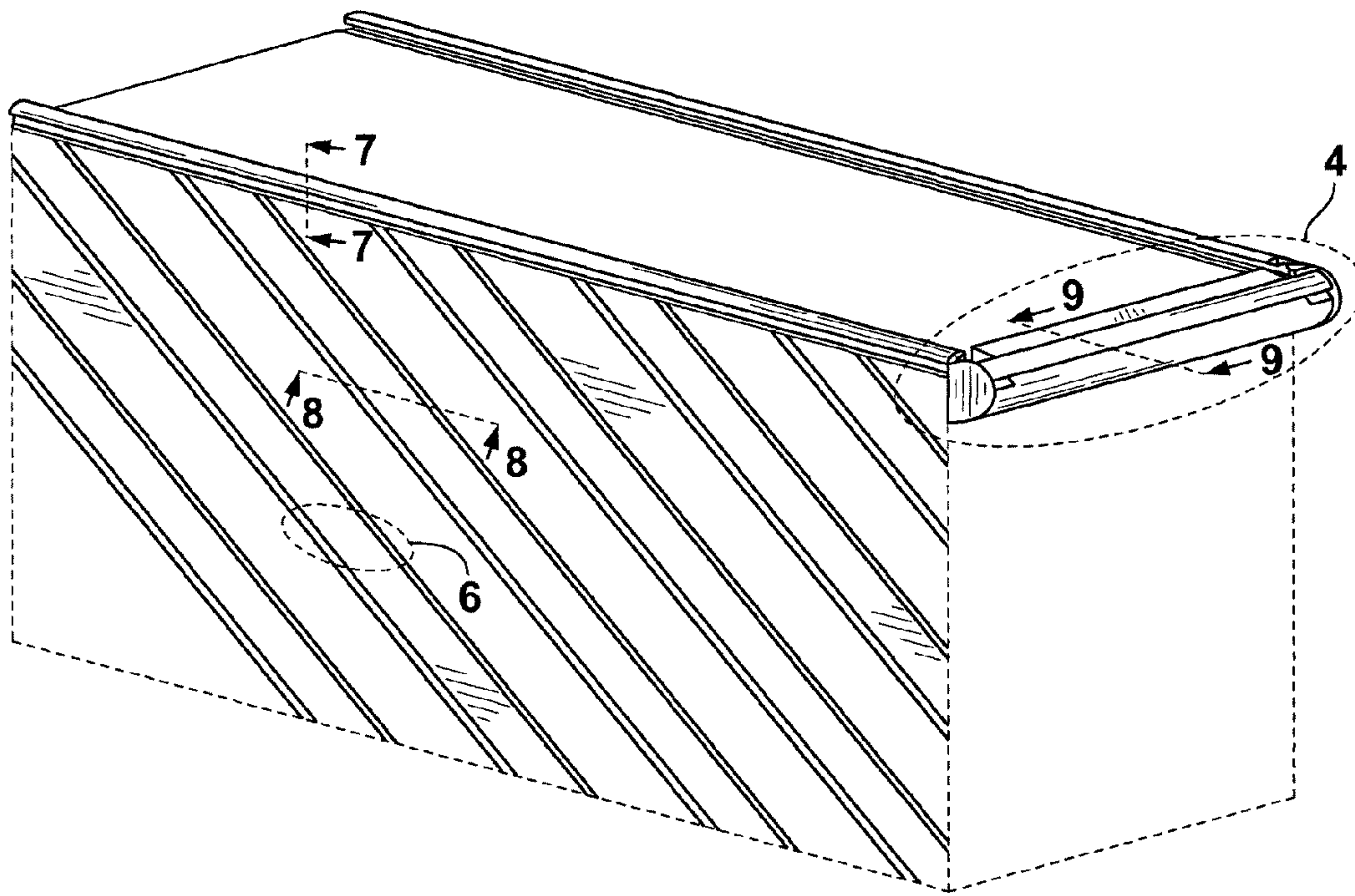

FIG. 1

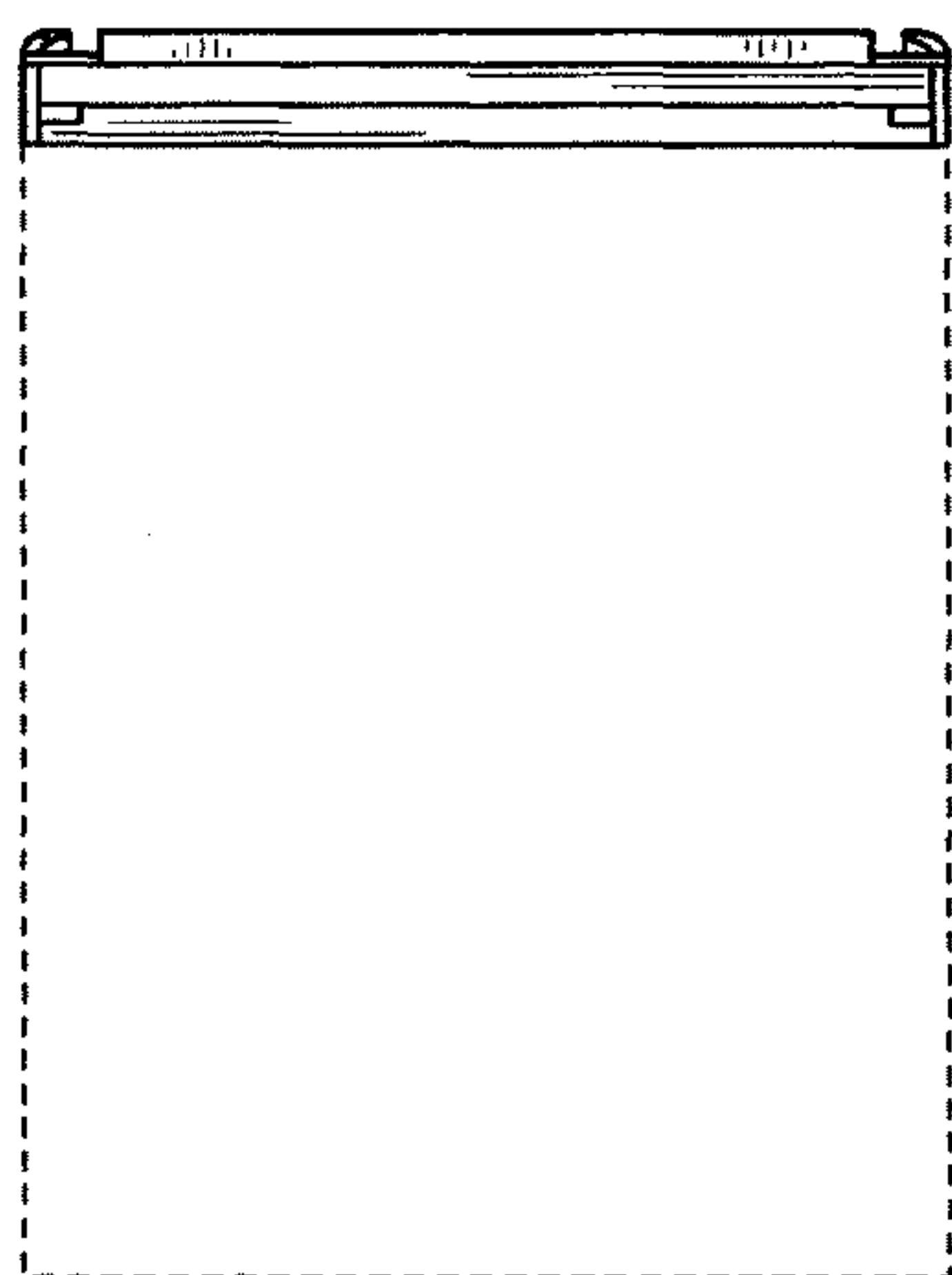

FIG. 2

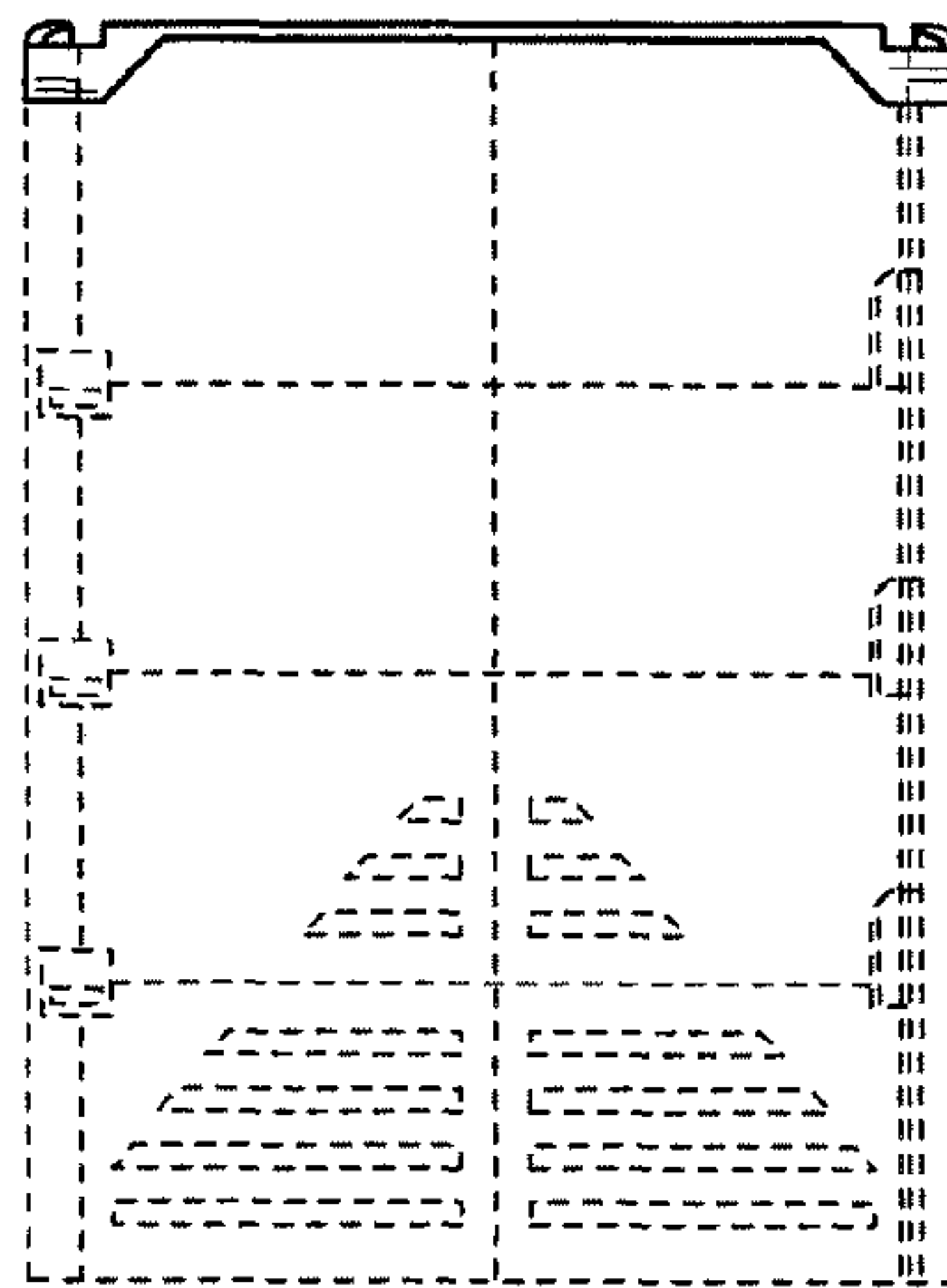

FIG. 3

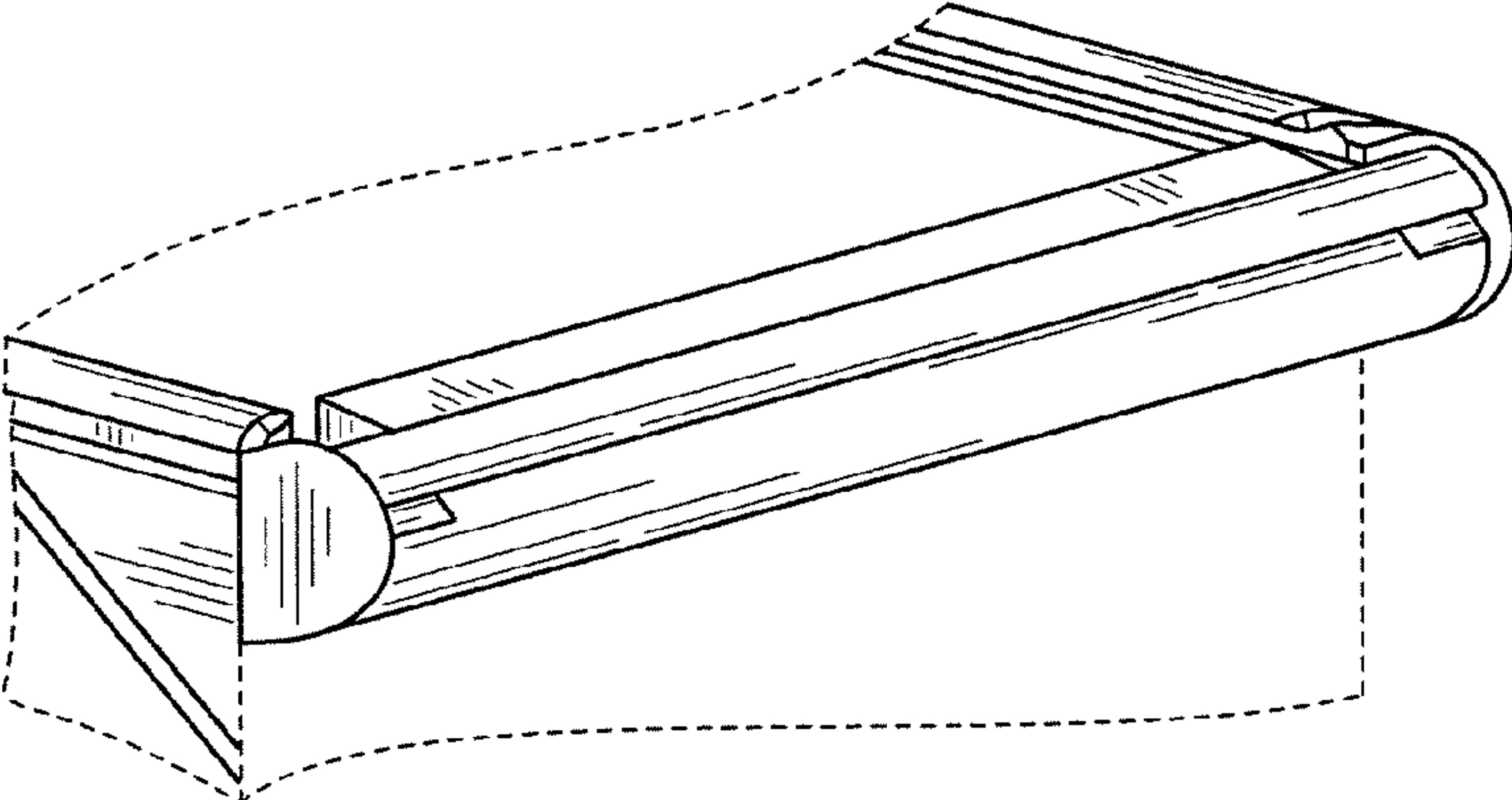

FIG. 4

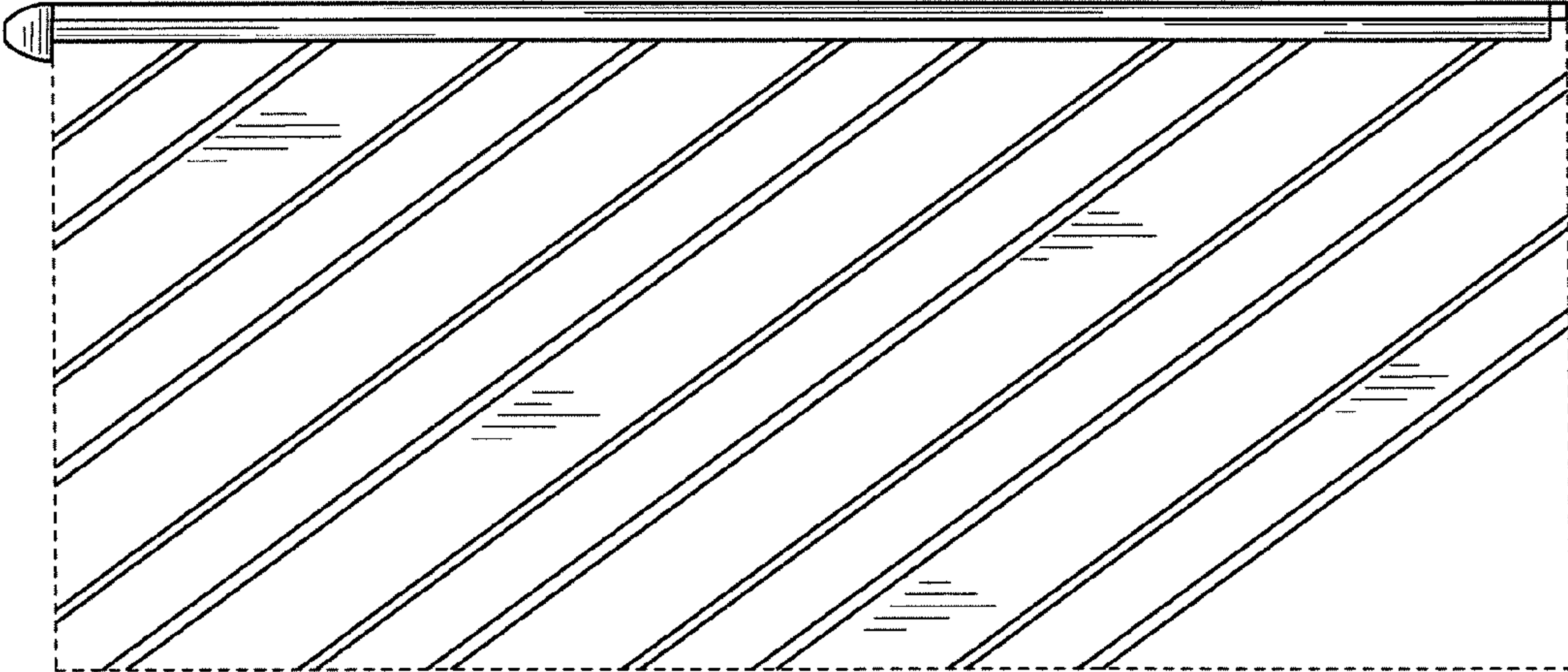

FIG. 5

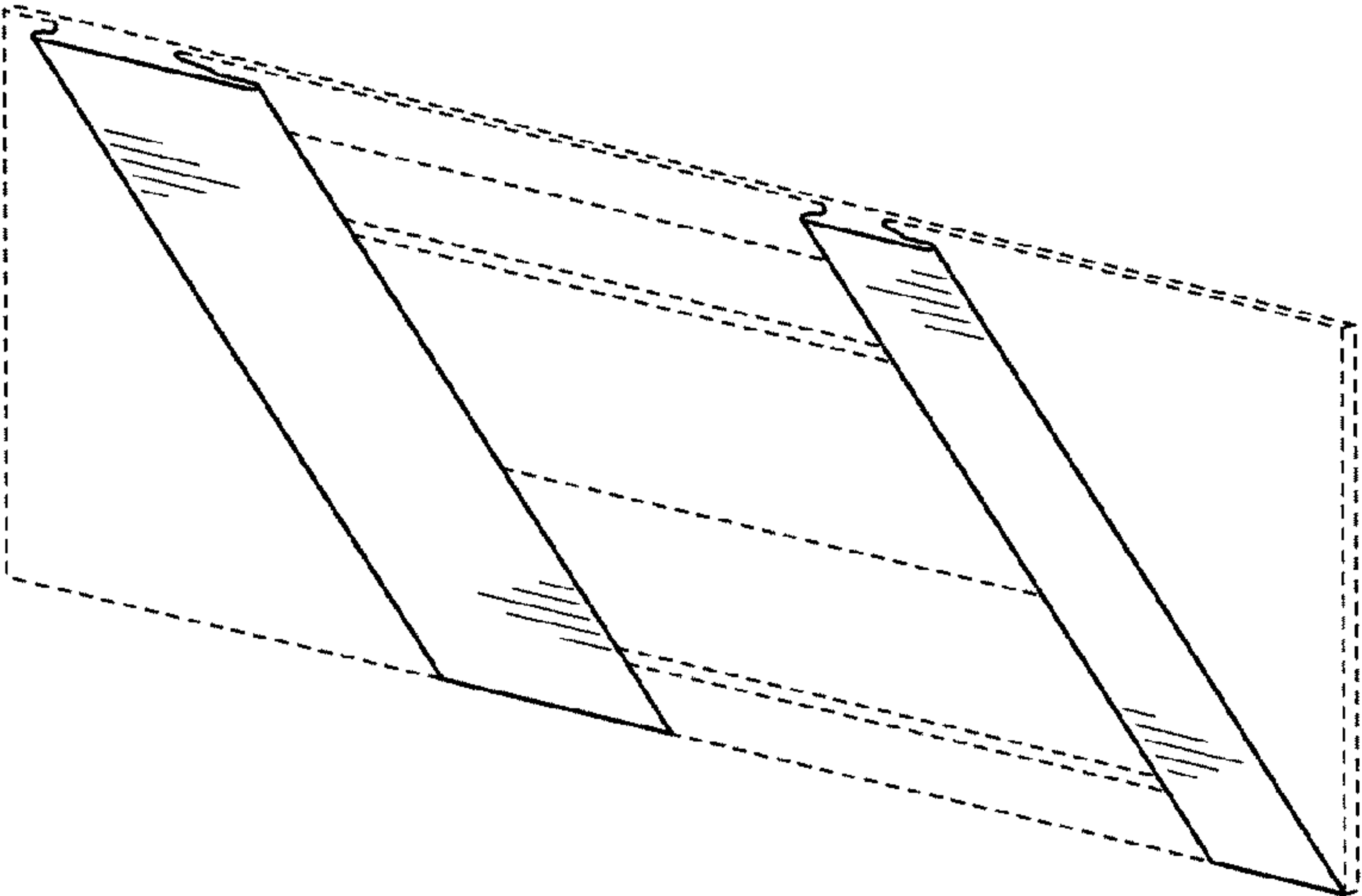

FIG. 6

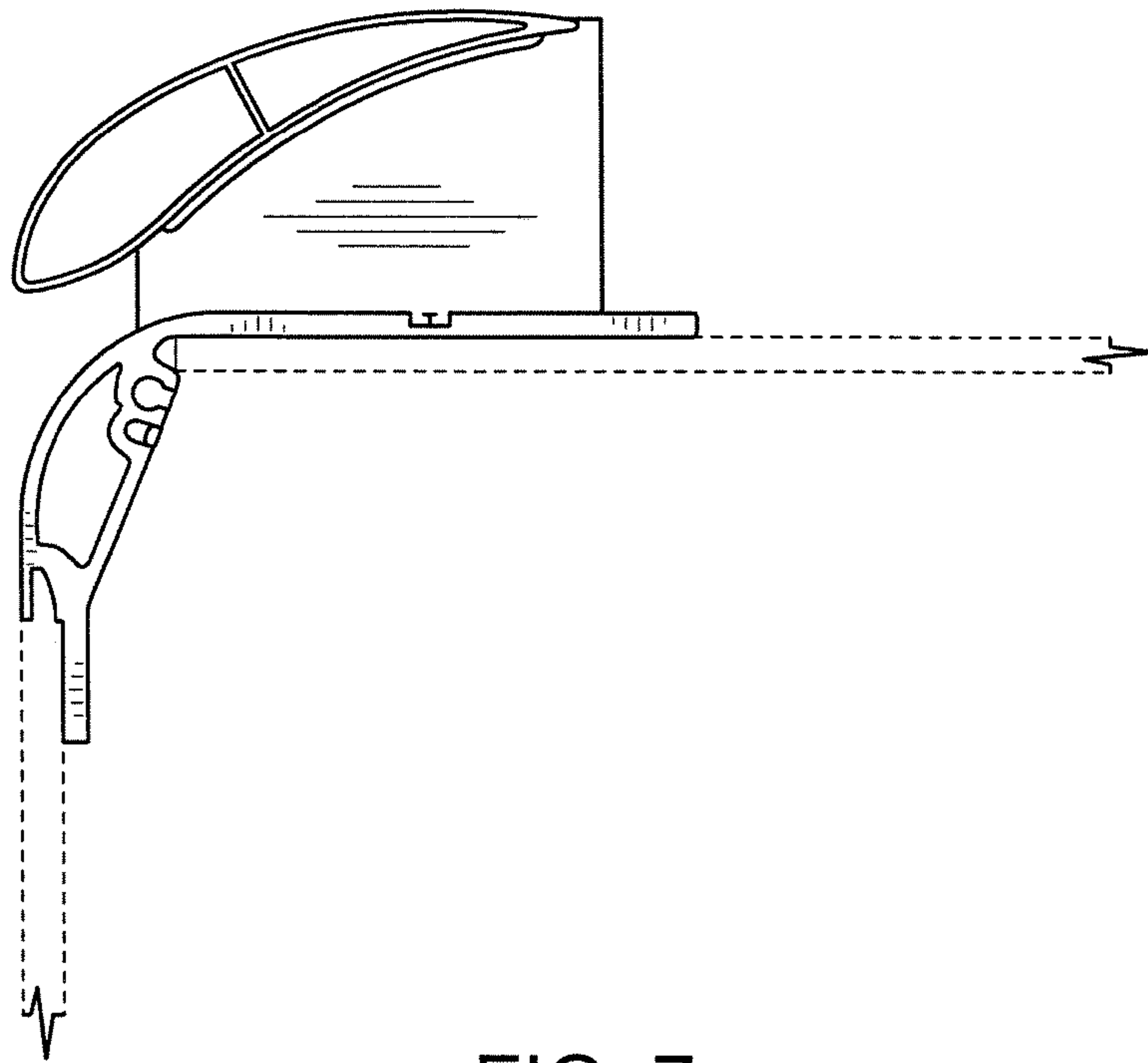

FIG. 7

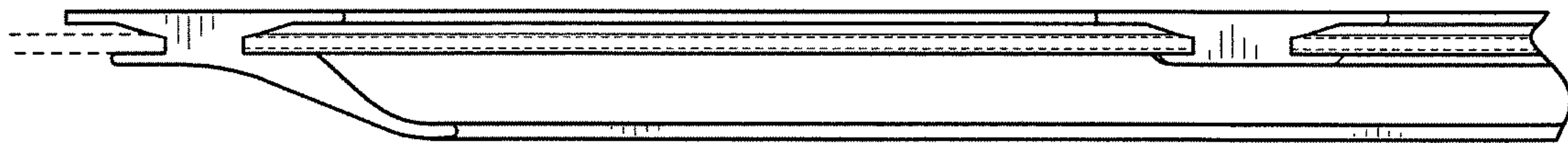

FIG. 8

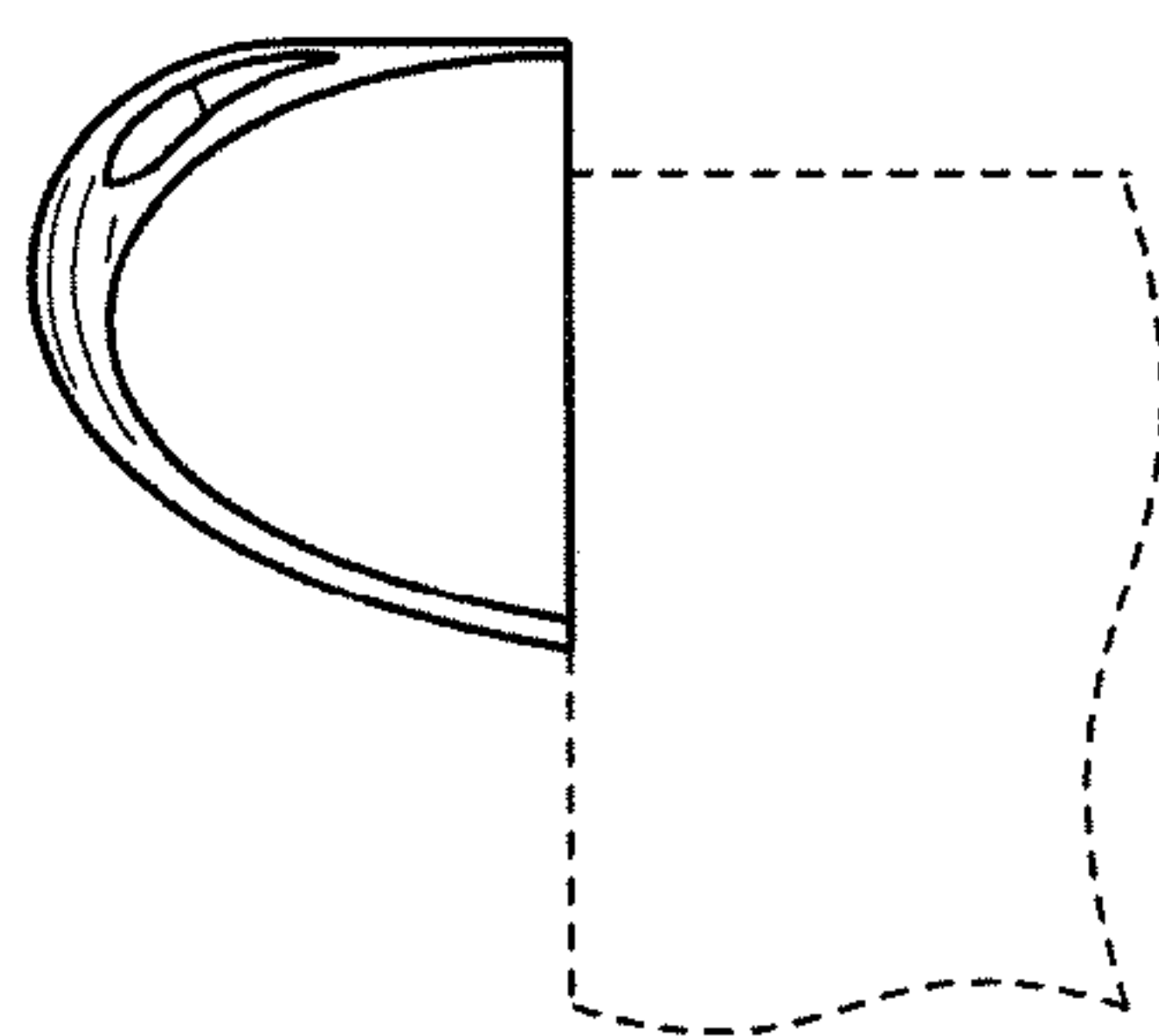

FIG. 9