



US00D645533S

(12) **United States Design Patent**
Peterson et al.

(10) **Patent No.:** **US D645,533 S**

(45) **Date of Patent:** **** Sep. 20, 2011**

(54) **MODULAR BUTTSTOCK SYSTEM FOR TACTICAL FIREARMS**

(75) Inventors: **Morris Peterson**, Earlysville, VA (US); **Matthew Peterson**, Crozet, VA (US); **Gary Vance**, Bristol, VA (US); **William McCormick**, Bluff City, TN (US); **Charles Robert Overbey, Jr.**, Deland, FL (US)

(73) Assignee: **Ashbury International Group, Inc.**, Ruckersville, VA (US)

(**) Term: **14 Years**

(21) Appl. No.: **29/340,270**

(22) Filed: **Jul. 15, 2009**

Related U.S. Application Data

(63) Continuation-in-part of application No. 12/251,384, filed on Oct. 14, 2008.

(51) **LOC (9) Cl.** **22-01**

(52) **U.S. Cl.** **D22/108**

(58) **Field of Classification Search** D22/100, D22/101, 103, 104, 108, 199; D21/572, D21/573; 42/51, 71.01, 75.01, 75.02, 90, 42/94, 134, 136, 139, 125, 72, 111; 362/110; 33/241, 277; 313/105 R; 89/40.06, 41.19, 89/37.04, 33.04, 191.01, 200-204; 124/67, 124/66, 74

See application file for complete search history.

(56) **References Cited**

U.S. PATENT DOCUMENTS

D517,637 S *	3/2006	Murello et al.	D22/103
D567,895 S *	4/2008	Cauley	D22/108
D600,307 S *	9/2009	Fitzpatrick et al.	D22/109
D603,013 S *	10/2009	Fitzpatrick et al.	D22/108
D606,614 S *	12/2009	Fitzpatrick et al.	D22/103
D607,078 S *	12/2009	Chu	D22/109
2008/0236016 A1 *	10/2008	Fitzpatrick et al.	42/71.01
2008/0236017 A1 *	10/2008	Fitzpatrick et al.	42/73

FOREIGN PATENT DOCUMENTS

DE 3743092 7/1988

OTHER PUBLICATIONS

“AW Rifle System”, Sales Brochure, Accuracy International Ltd. (Apr. 7, 2006) available at http://www.accuracyinternational.com/assets/assets/aw_brochure.pdf. “AICS (Accuracy International Chassis System) Upgrade Kit for Remington 700”, Sales Brochure, Accuracy International Ltd. (Apr. 7, 2006) available at http://www.accuracyinternational.com/assets/assets/aics_brochure.pdf. “Timerwolf 338 Lapua”, Webpage, Colt Canada Corp. (Jun. 25, 2007) available at <http://www.coltcanada.com/timberwolf-page.htm>. “Colt Canada”, Sales Catalog, Colt Canada Corp. (Feb. 21, 2008) available at <http://www.coltcanada.com/PDF%20Forms/CC-cat-web.pdf>. “Owner’s and Maintenance Manual for Sako TRG 22/42 Sharpshooting System”, Owner’s Manual, Sako Ltd (Sep. 2, 1993) available at http://www.sako.fi/pdf/manuals/TRG22_42.pdf. “Specification—Sako TRG Sharpshooting System”, Specification, Sako Ltd. (Sep. 28, 2001) available at <http://www.sako.fi/pdf/specs/TRG.pdf>. “Specification—Sako TRG Sharpshooting System”, Specification, Sako Ltd. (Dec. 19, 2008) available at <http://www.sako.fi/pdf/specs/TRG.pdf>. “Hecate II: Long-Range Anti-Material Rifle”, Sales Brochure, PGM Precision (Dec. 12, 2008) available at http://www.pgmprecision.com/uploads/pdf/hecate_2008_en.pdf. “A.M.S.D. Sniper Rifle”, Specification, Advanced Military System Design (Apr. 21, 2006) available at <http://www.amsd.ch/products/nemesis/om50nemesis.pdf>. “Sako Export 2008”, Sales Catalog, 2008, Sako Ltd. (Apr. 1, 2008) available at http://www.sako.fi/pdf/sako_export_2008.pdf. “JP MOR-07 Manually Operated Rifle”, Webpage, J.P. Enterprises, Inc. (Jan. 5, 2007) available at <http://www.jp Rifles.com/1.2.6.php>. “MBAR”, Webpage, Halo Arms, LLC (Dec. 12, 2006) available at <http://www.haloarms.com/MBAR.html>. “MP-MODSS (Mcree’s Precision Modular Stock System)”, Webpage, McCre’e’s Multi Services (Aug. 16, 2007) available at <http://www.mcreeprecision.net/index.htm>. “A.R.M.S. #50 M-CV, and #58 M-CV MOD SIR System”, Sales Brochure, A.R.M.S., Inc. (Nov. 5, 2009) available at <http://www.armsmounts.com/manuals/50M-CV%20Manual.pdf>.

* cited by examiner

Primary Examiner — T. Chase Nelson

Assistant Examiner — Michael Pratt

(74) *Attorney, Agent, or Firm* — Troutman Sanders LLP; Robert R. Elliott, Jr.

(57) **CLAIM**

The ornamental design for a modular buttstock system for tactical firearms, as shown and described.

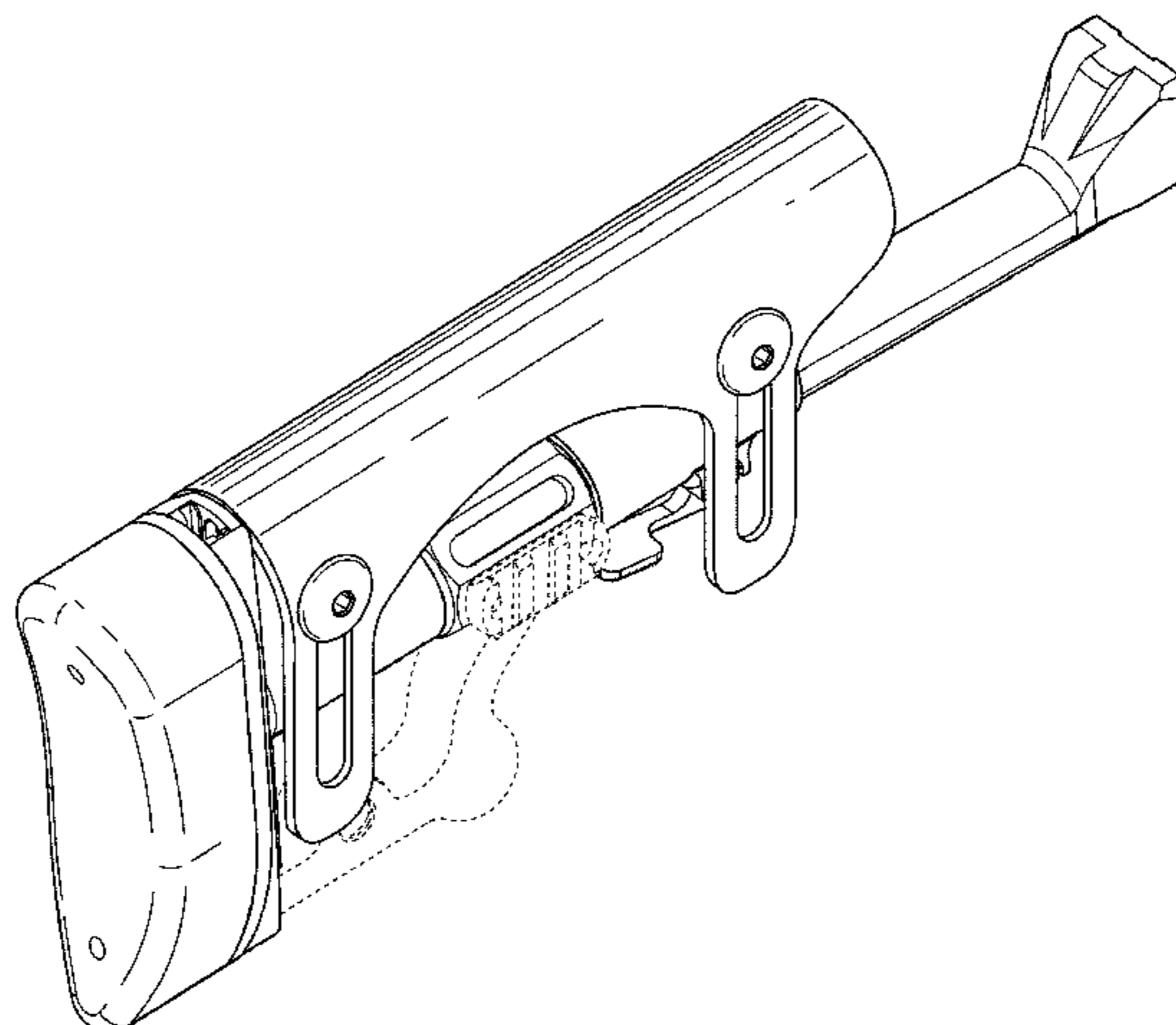

DESCRIPTION

FIG. 1 illustrates a perspective, side view of a new design for a modular buttstock system for tactical rifles depicting a modular buttstock with an adjustable length of pull, comb/cheekpiece, and butt plate/recoil pad, wherein an optional butthook and attachment rail surface are coupled to the buttstock system;

FIG. 2 is a side view of the design shown in FIG. 1 depicting a modular buttstock with an adjustable length of pull, an adjustable comb/cheekpiece, and an adjustable butt plate/recoil pad;

FIG. 3 is a side view of the design shown in FIG. 1 depicting a modular buttstock with an adjustable length of pull, comb/cheekpiece, and butt plate/recoil pad;

FIG. 4 is a top view of the design shown in FIG. 1 depicting a modular buttstock with an adjustable length of pull, comb/cheekpiece, and butt plate/recoil pad;

FIG. 5 is a bottom view of the design shown in FIG. 1 depicting a modular buttstock with an adjustable length of pull, comb/cheekpiece, and butt plate/recoil pad;

FIG. 6 is a rear view of the design shown in FIG. 1 depicting a modular buttstock with an adjustable length of pull, comb/cheekpiece, and butt plate/recoil pad;

FIG. 7 is a front view of the design shown in FIG. 1 depicting a modular buttstock with an adjustable length of pull, comb/cheekpiece, and butt plate/recoil pad;

FIG. 8 is a perspective, side view of the design shown in FIG. 1 depicting a modular buttstock with an adjustable length of pull, comb/cheekpiece, and butt plate/recoil pad, wherein an optional monopod and attachment rail surface are coupled to the buttstock system;

FIG. 9 is a side view of the design shown in FIG. 1 depicting a modular buttstock with an adjustable length of pull, comb/cheekpiece, and butt plate/recoil pad;

FIG. 10 is a side view of the design shown in FIG. 1 depicting a modular buttstock with an adjustable length of pull, comb/cheekpiece, and butt plate/recoil pad;

FIG. 11 is a top view of the design shown in FIG. 1 depicting a modular buttstock with an adjustable length of pull, comb/cheekpiece, and butt plate/recoil pad;

FIG. 12 is a bottom view of the design shown in FIG. 1 depicting a modular buttstock with an adjustable length of pull, comb/cheekpiece, and butt plate/recoil pad;

FIG. 13 is a cross-sectional view of the design shown in FIG. 1 depicting a modular buttstock with an adjustable length of

pull, comb/cheekpiece, and butt plate/recoil pad, wherein an optional monopod is coupled to the buttstock system;

FIG. 14 is a cross-sectional view of the design shown in FIG. 1 depicting a modular buttstock with an adjustable length of pull, comb/cheekpiece, and butt plate/recoil pad, wherein an optional monopod is coupled to the buttstock assembly;

FIG. 15 is a perspective, side view of the design shown in FIG. 1 depicting a modular buttstock with an adjustable length of pull, comb/cheekpiece, and butt plate/recoil pad, wherein the comb/cheekpiece is shown in an raised position;

FIG. 16 is a perspective, side view of the design shown in FIG. 1 depicting a modular buttstock with an adjustable length of pull, comb/cheekpiece, and butt plate/recoil pad, wherein the comb/cheekpiece is shown in an raised position;

FIG. 17 is a perspective, side view of the design shown in FIG. 1 depicting a modular buttstock folded with an adjustable length of pull, comb/cheekpiece, and butt plate/recoil pad, wherein the modular buttstock is shown in context with a stock-firearm chassis system;

FIG. 18 is a side view of the design shown in FIG. 1 depicting a modular buttstock with an adjustable length of pull, comb/cheekpiece, and butt plate/recoil pad, wherein the modular buttstock is shown in context with a stock-firearm chassis system;

FIG. 19 is an exploded, perspective, side view of the design shown in FIG. 1 depicting a modular buttstock with an adjustable length of pull, comb/cheekpiece, and butt plate/recoil pad, wherein an optional rail attachment surface is shown in an exploded position from the modular buttstock;

FIG. 20 is an exploded, perspective, side view of the design shown in FIG. 1 depicting a modular buttstock with an adjustable length of pull, comb/cheekpiece, and butt plate/recoil pad, wherein an optional monopod and rail attachment surface are shown in an exploded position from the modular buttstock; and,

FIG. 21 is an exploded, perspective, side view of the design shown in FIG. 1 depicting a modular buttstock with an adjustable length of pull, comb/cheekpiece, and butt plate/recoil pad, wherein an optional butthook and rail attachment surface are shown in an exploded position from the modular buttstock.

The broken, dashed lines shown in the various figures depicting embodiments of the invention are included for the purpose of illustrating environment and do not form any part of the claimed design.

1 Claim, 15 Drawing Sheets

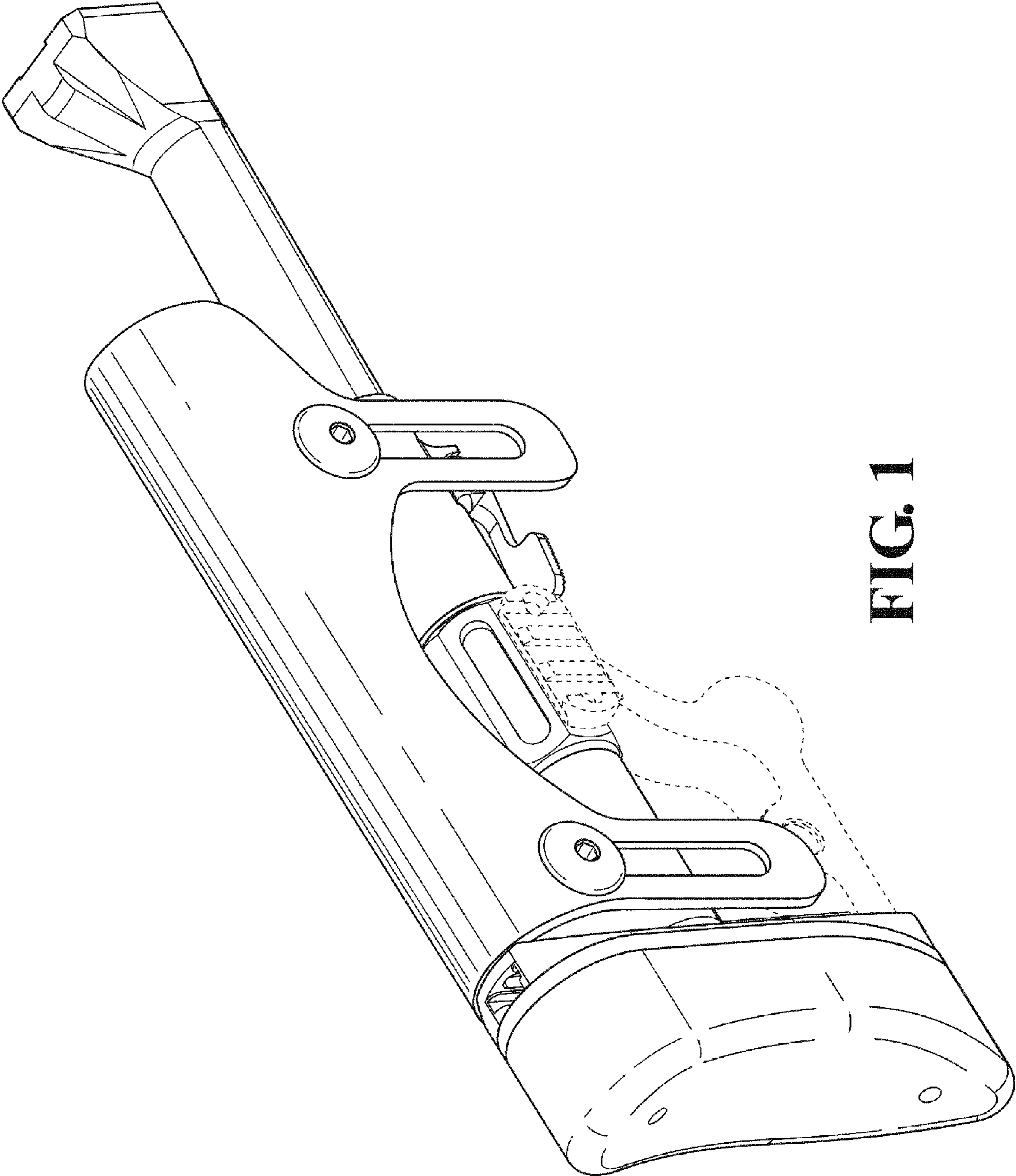

FIG. 1

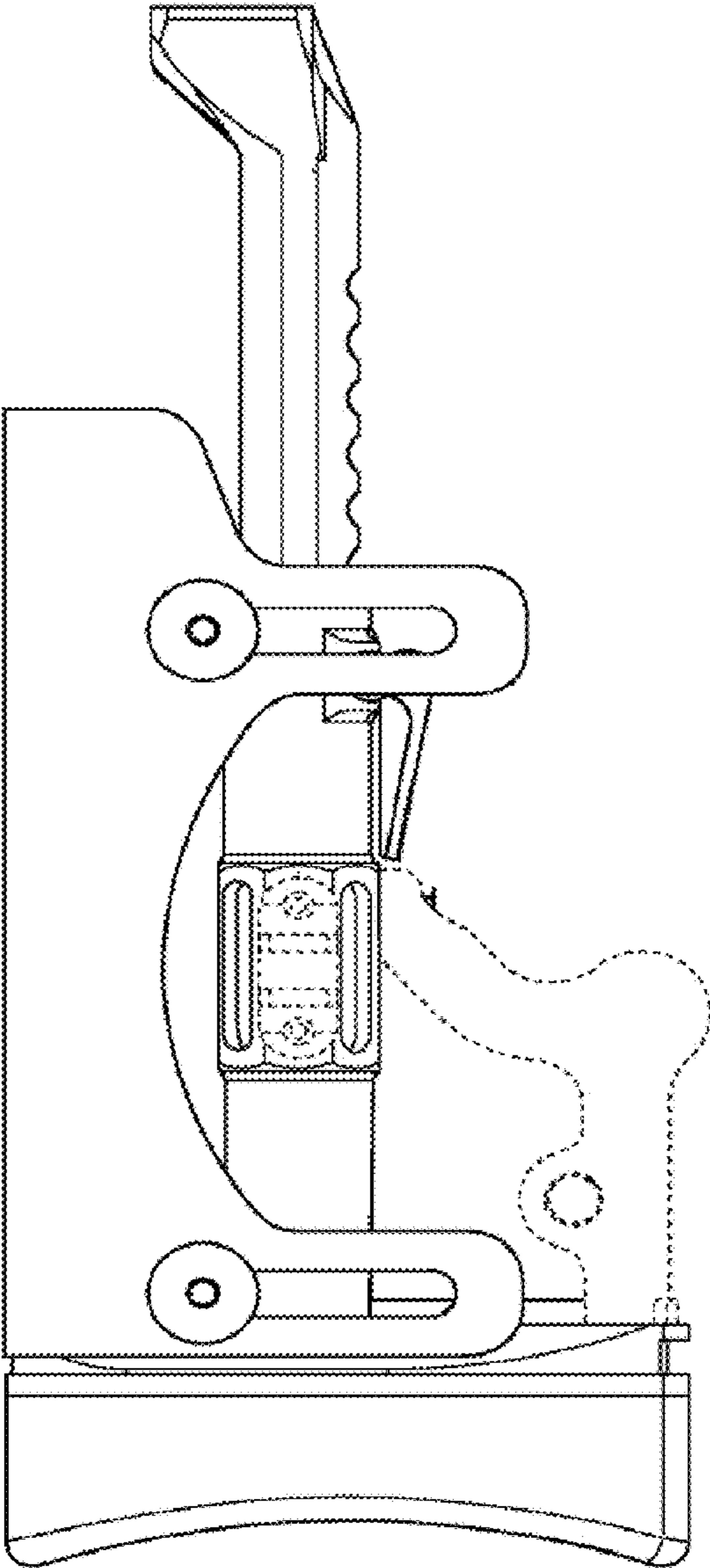

FIG. 2

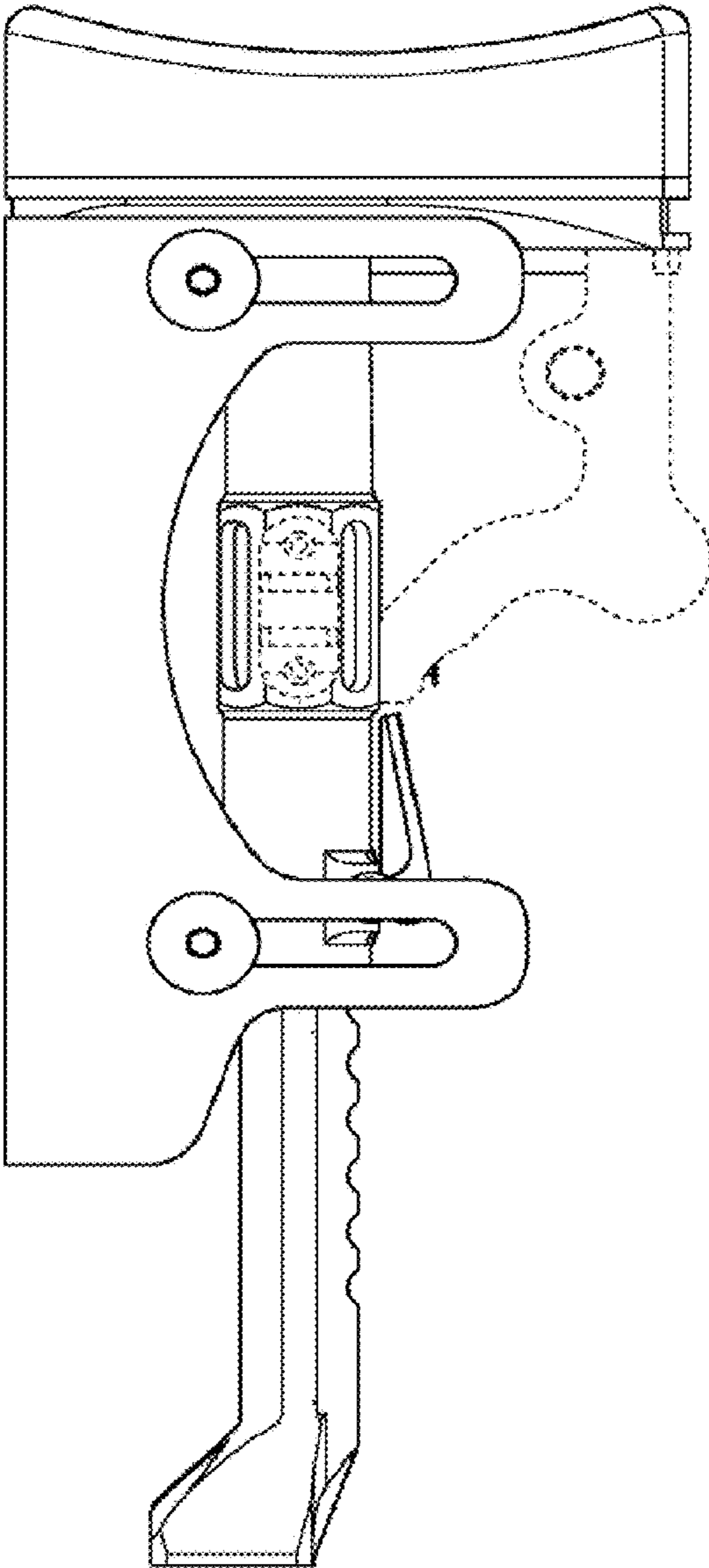

FIG. 3

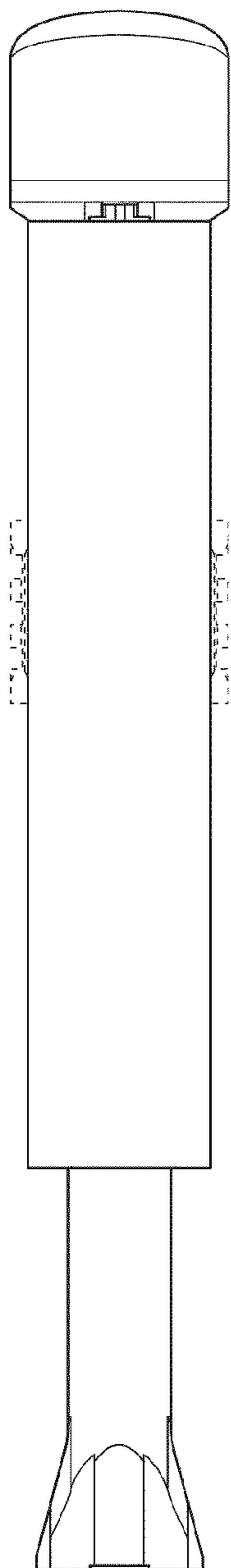

FIG. 4

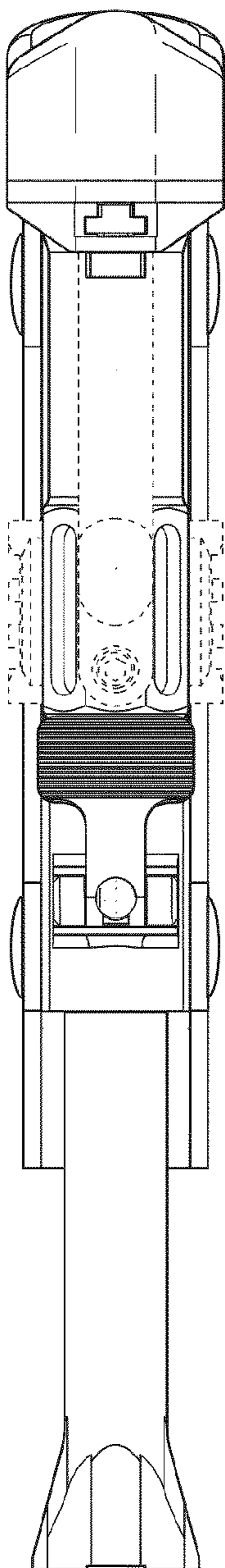

FIG. 5

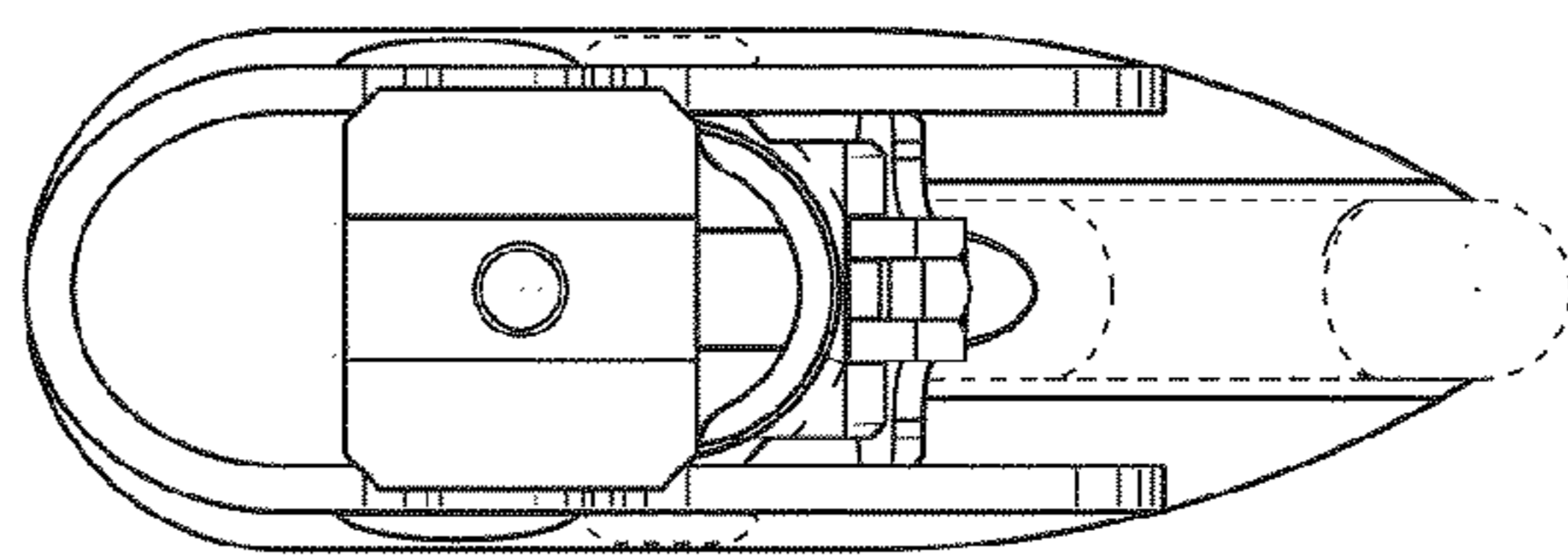

FIG. 7

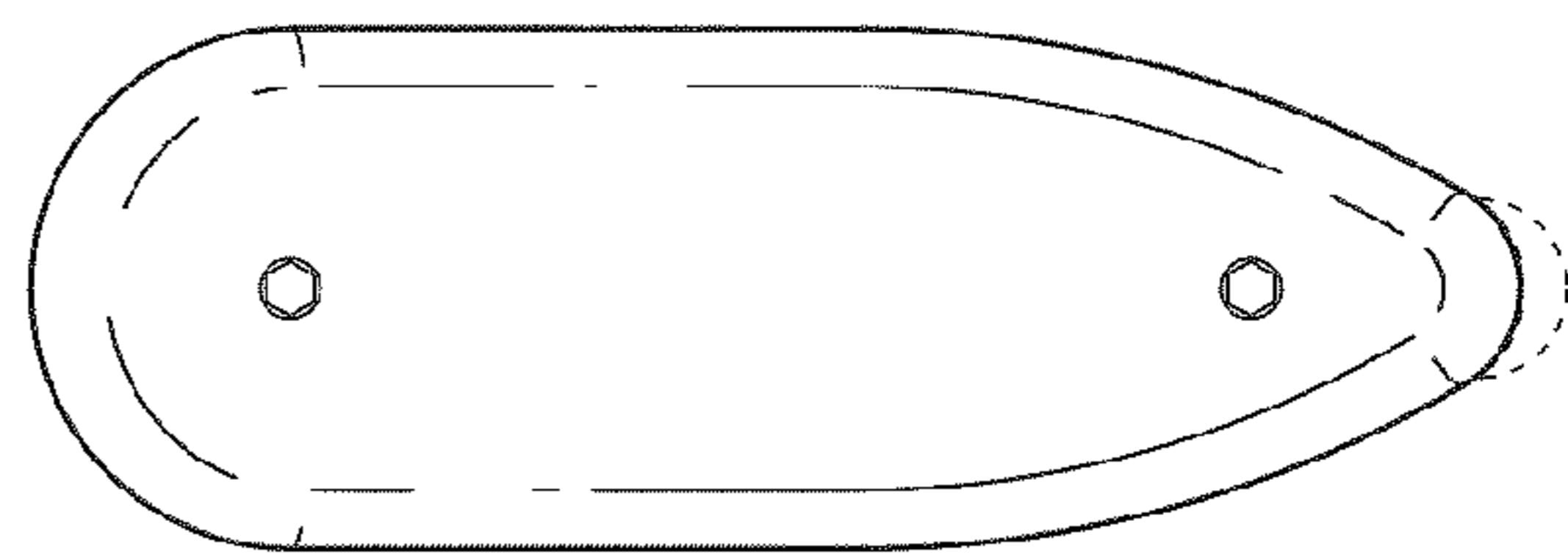

FIG. 6

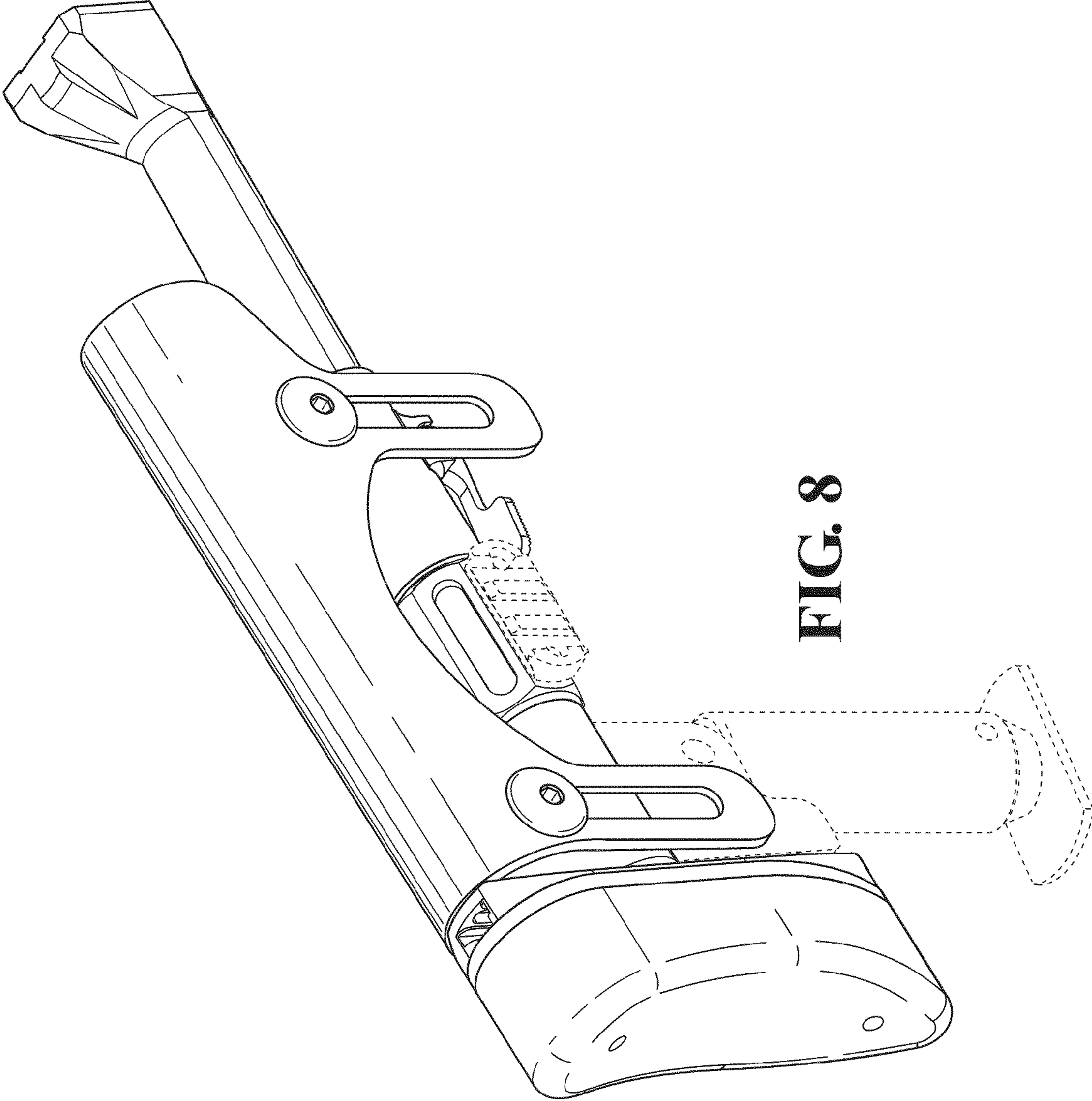

FIG. 8

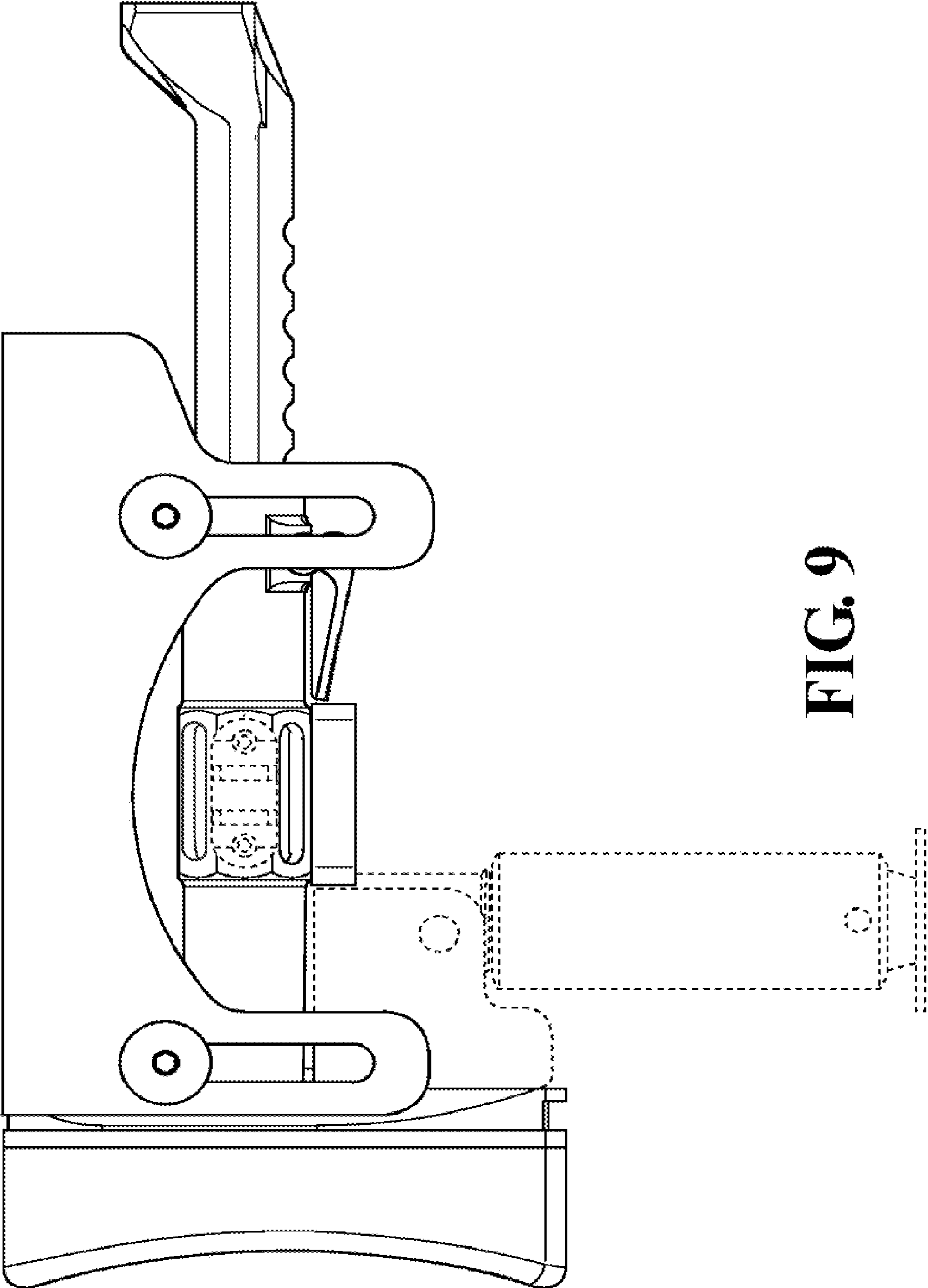

FIG. 9

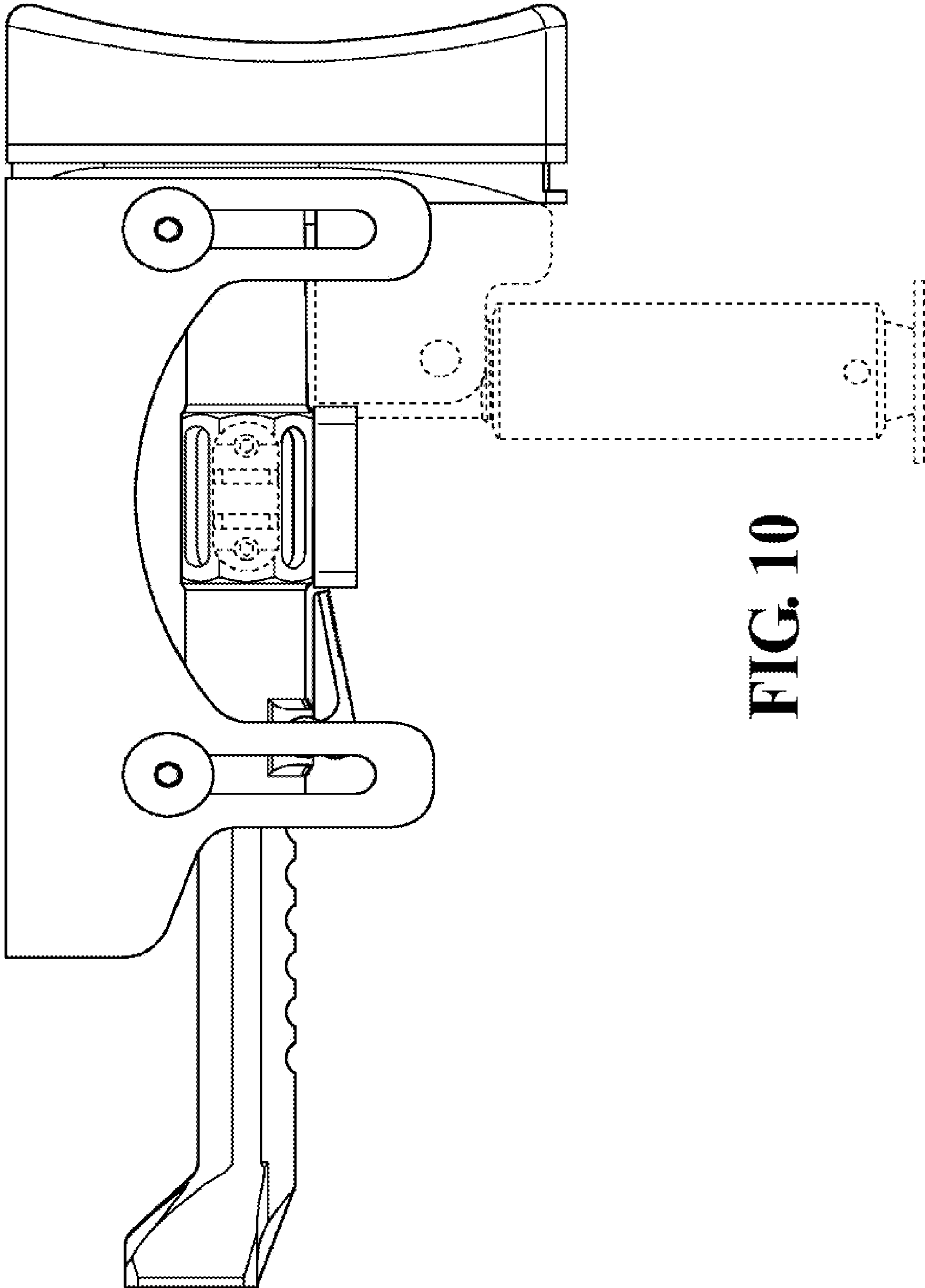

FIG. 10

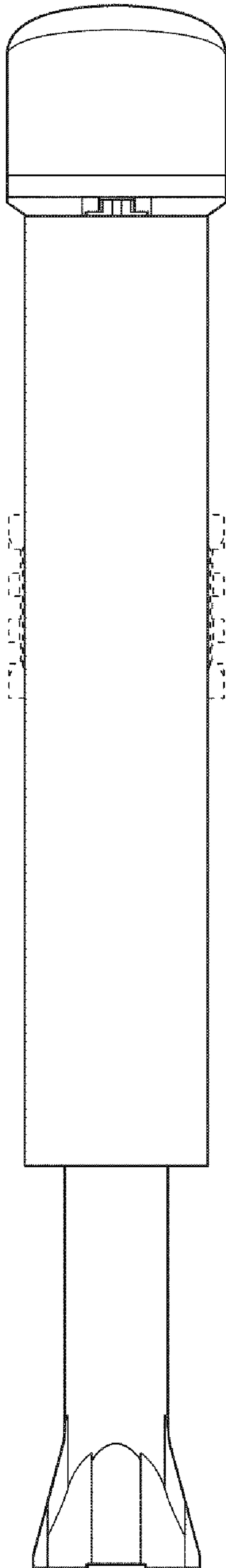

FIG. 11

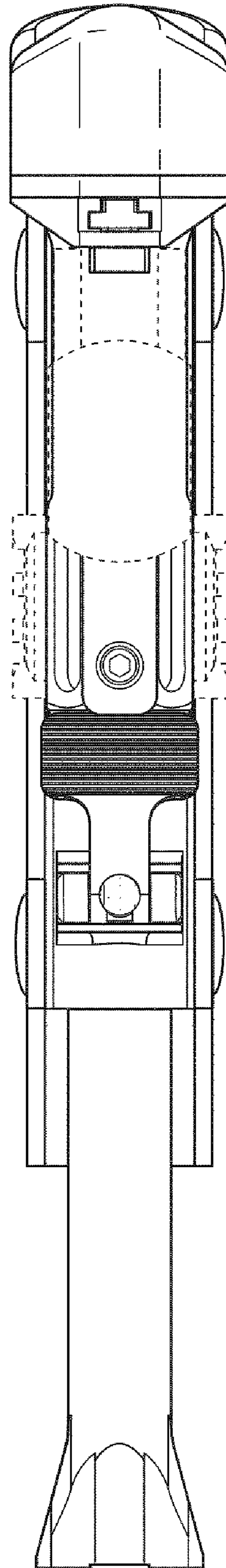

FIG. 12

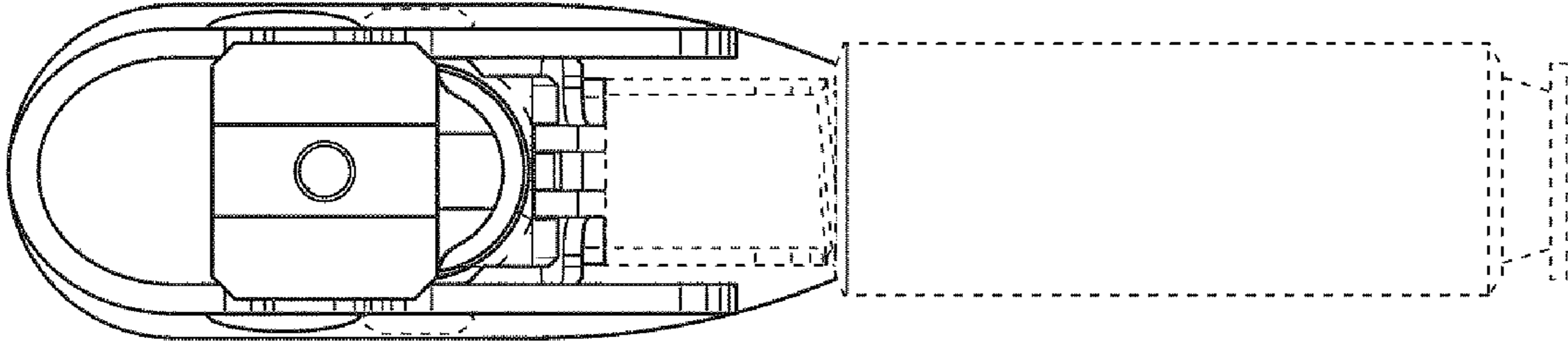

FIG. 14

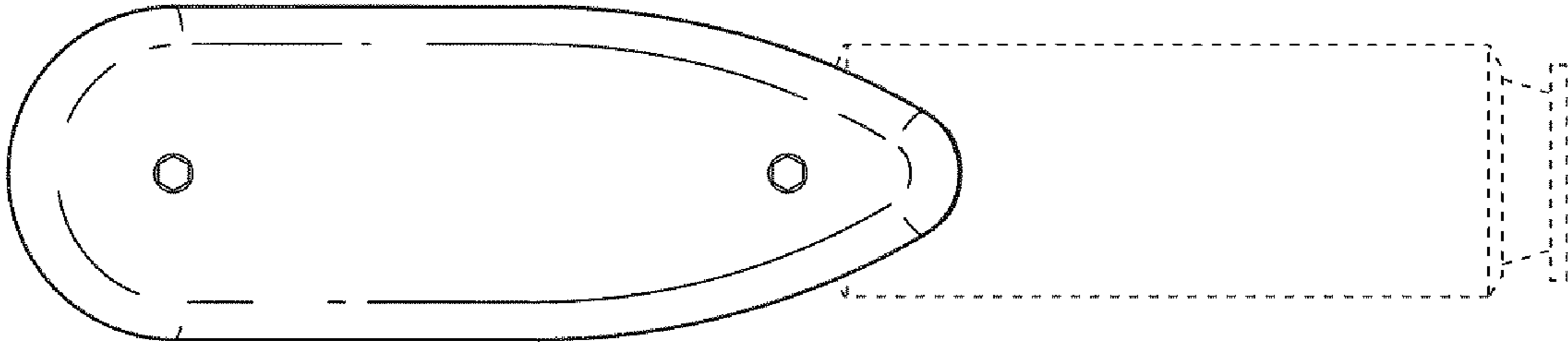

FIG. 13

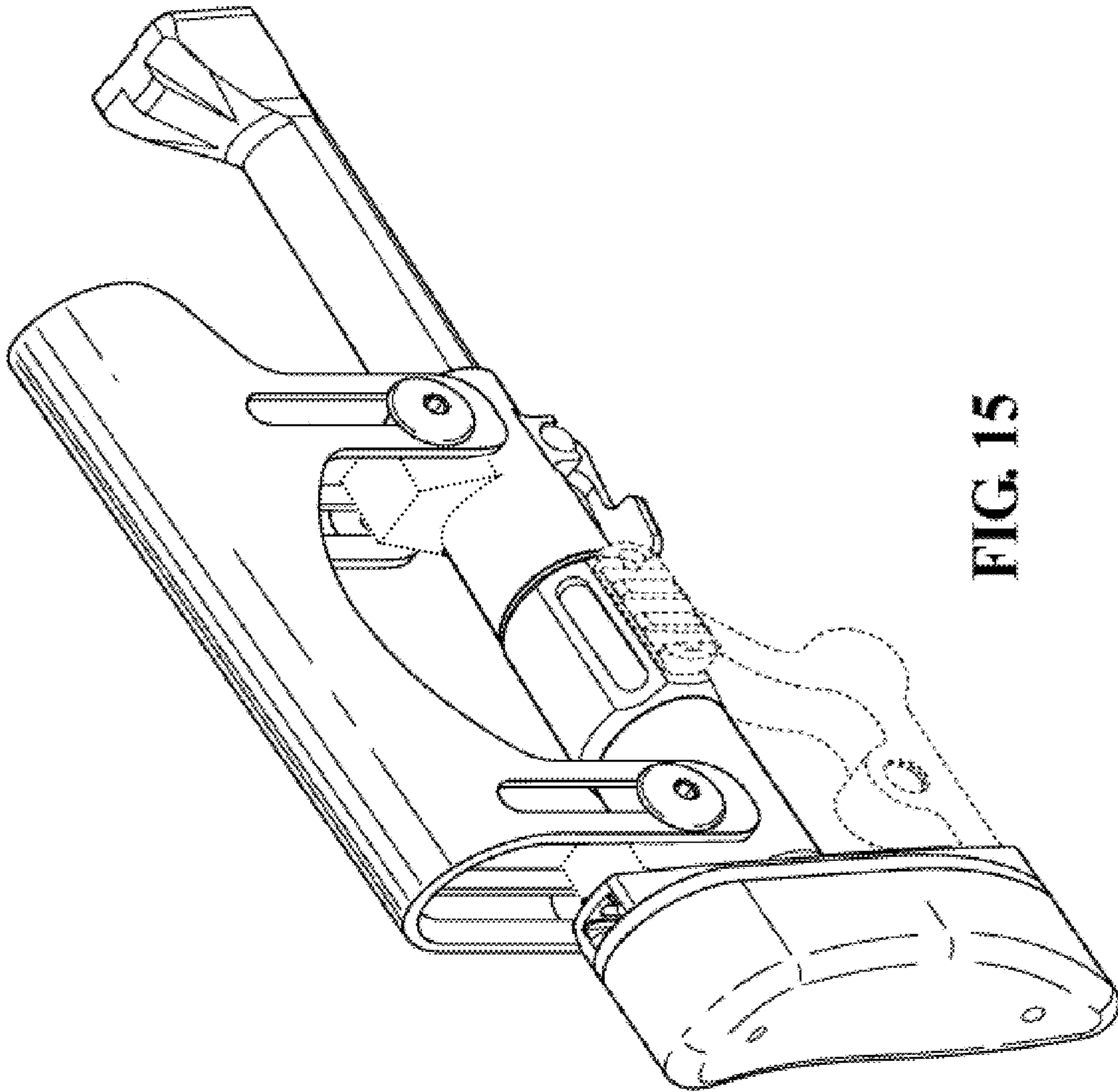

FIG. 15

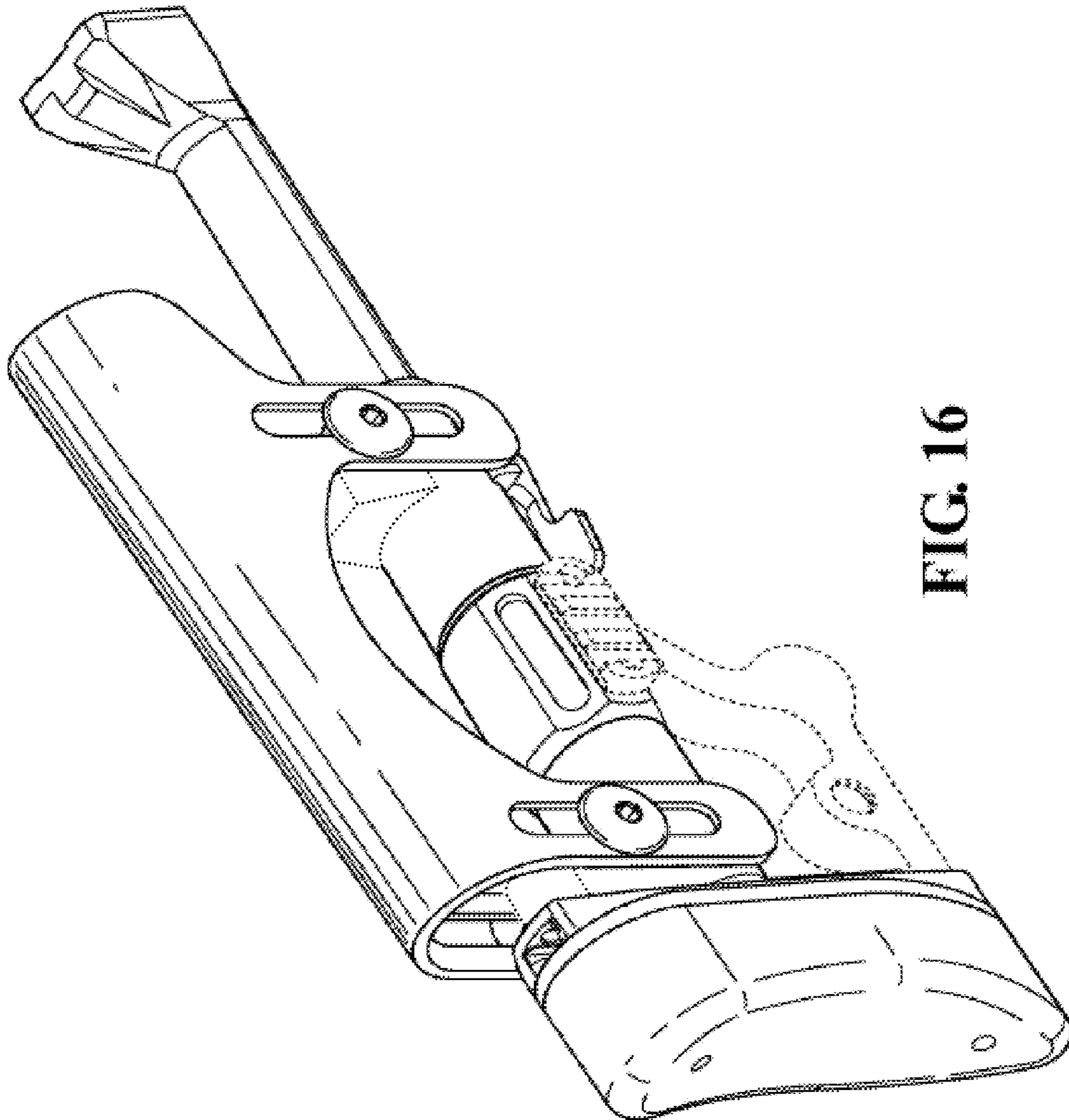

FIG. 16

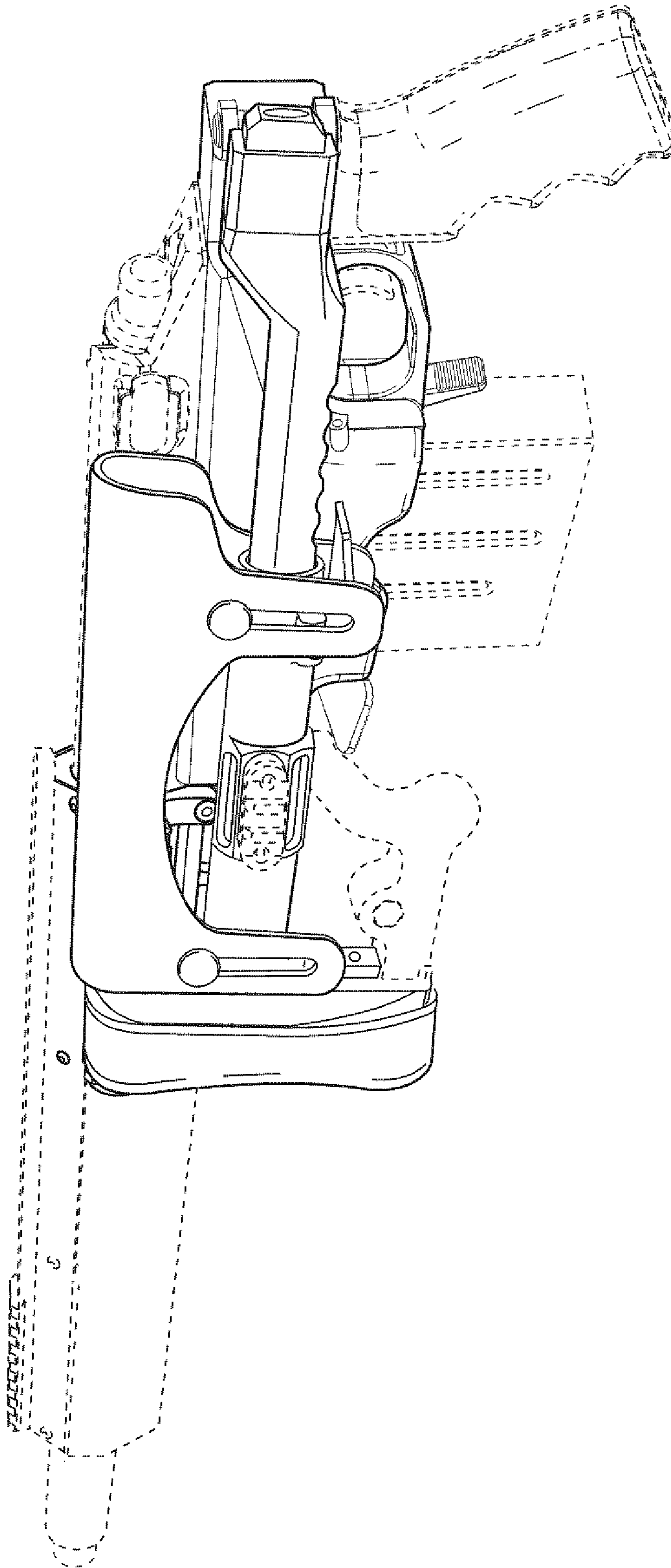

FIG. 17

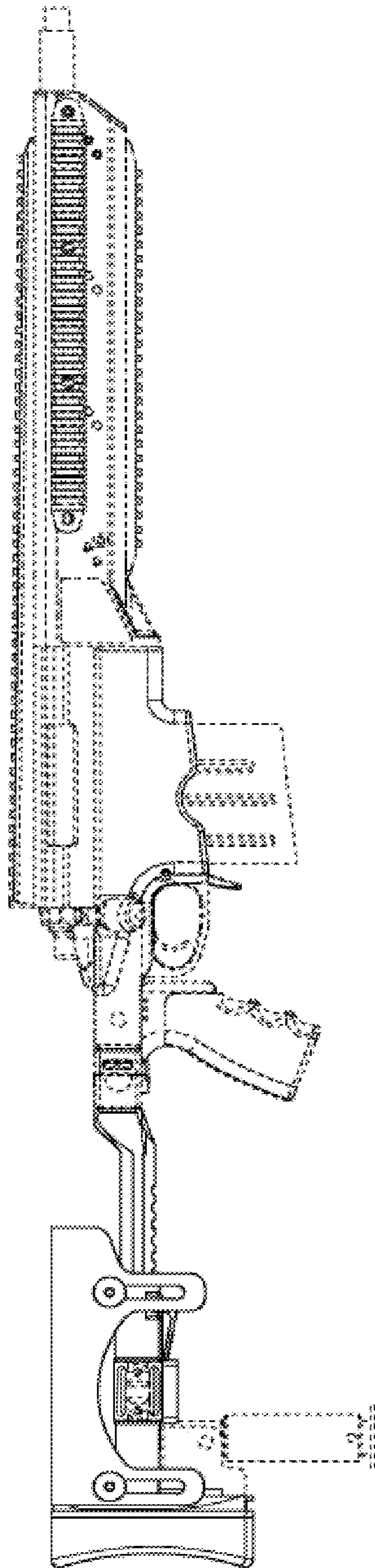

FIG. 18

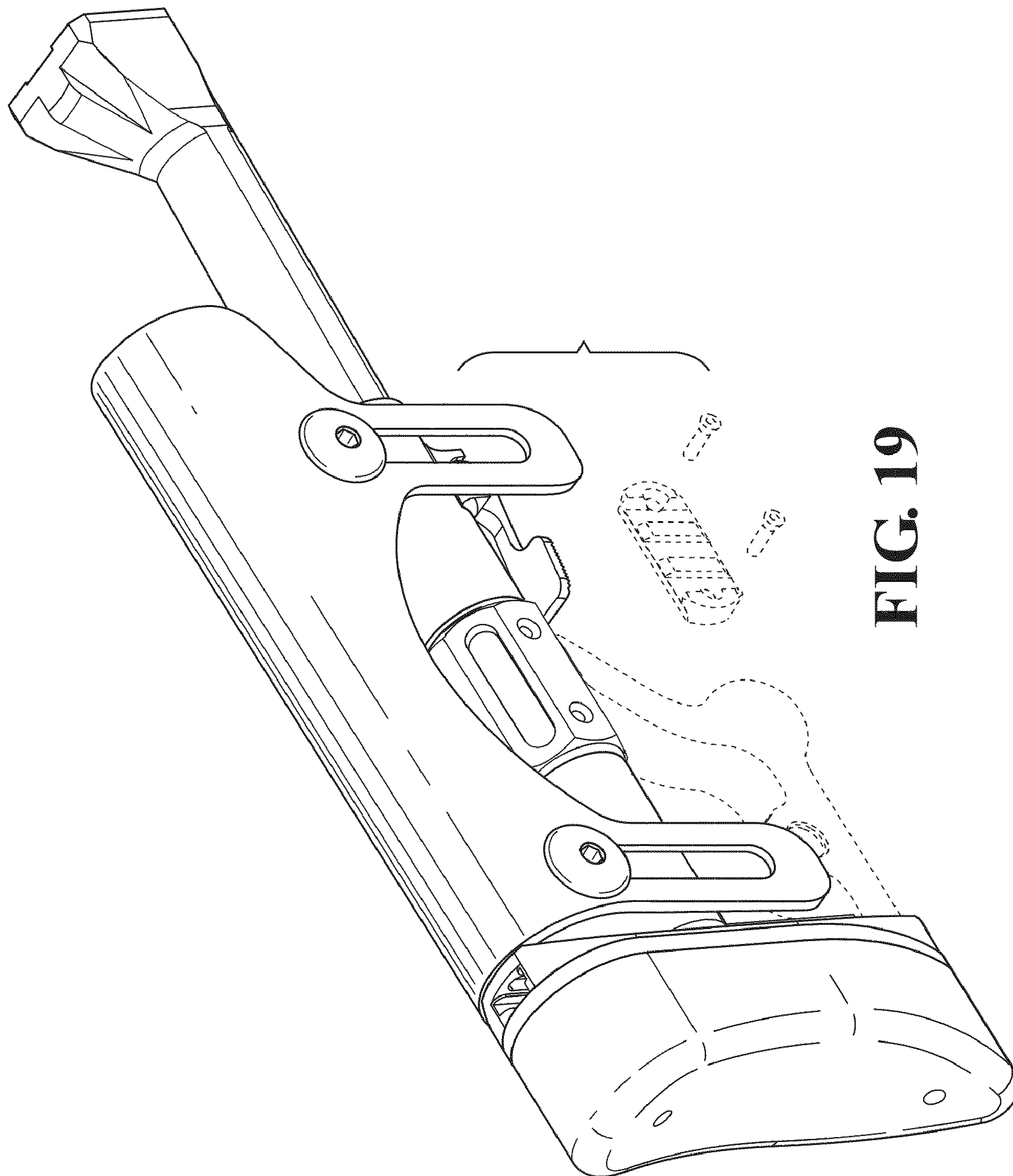

FIG. 19

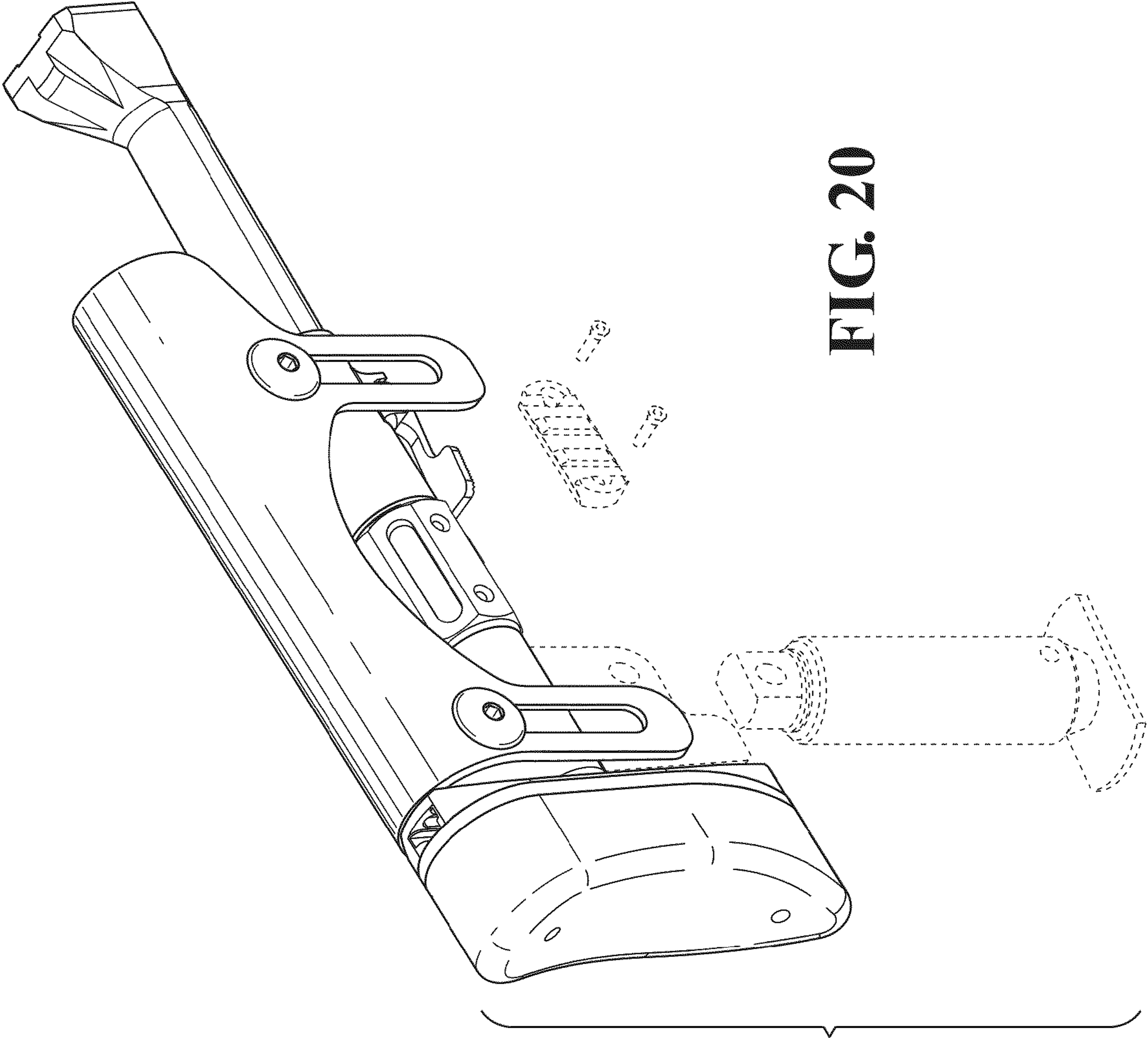

FIG. 20

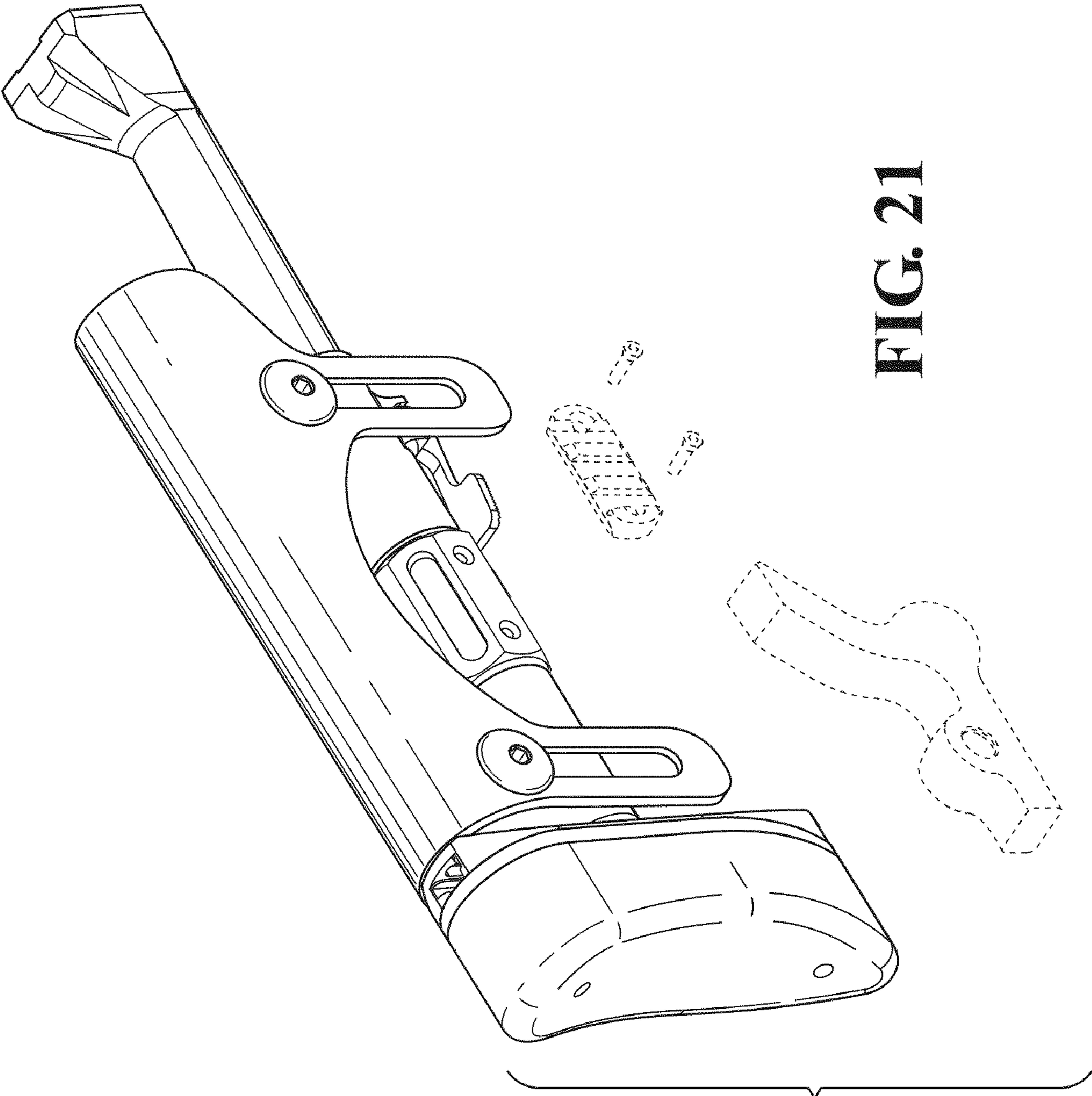

FIG. 21