



US00D645367S

(12) **United States Design Patent**
Hayashi et al.

(10) **Patent No.:** **US D645,367 S**

(45) **Date of Patent:** **** Sep. 20, 2011**

(54) **AUTOMATED ANALYZER**

DESCRIPTION

- (75) Inventors: **Yoshihiro Hayashi**, Shizuoka (JP);
Shigeru Fujii, Shizuoka (JP)
- (73) Assignee: **Beckman Coulter, Inc.**, Brea, CA (US)
- (**) Term: **14 Years**
- (21) Appl. No.: **29/376,231**
- (22) Filed: **Oct. 4, 2010**
- (30) **Foreign Application Priority Data**

Apr. 5, 2010 (JP) 2010-8573
 Apr. 5, 2010 (JP) 2010-8574
 Apr. 5, 2010 (JP) 2010-8575

(51) **LOC (9) Cl.** **10-04**

(52) **U.S. Cl.** **D10/81**

(58) **Field of Classification Search** D10/78,
 D10/94, 81; D24/216, 232, 234; 702/32,
 702/19; 600/300; 455/569.2; 324/72.5,
 324/110, 114, 115, 149, 151 A, 158 F, 156,
 324/556, 133, 503, 543, 555, 66, 72, 754;
 340/653, 660, 635; 439/482; 422/63-83,
 422/99, 100, 58, 61, 82.05; 423/43; 436/164,
 436/166, 169, 605; 356/246, 336, 410, 417,
 356/335, 340, 28.5; 362/119; 435/14, 283.1,
 435/287.1, 4, 970; 73/865.5; 377/10, 37,
 377/53; 430/137.14

See application file for complete search history.

(56) **References Cited**

U.S. PATENT DOCUMENTS

D294,948 S * 3/1988 Pogue et al. D15/147
 (Continued)

Primary Examiner — Antoine D Davis

(74) *Attorney, Agent, or Firm* — Kilpatrick Townsend & Stockton LLP

(57) **CLAIM**

The ornamental design for an automated analyzer, as shown and described.

FIG. 1 is a left-side perspective view of a first embodiment of the automated analyzer showing our new design.
 FIG. 2 is a right-side perspective view thereof.
 FIG. 3 is a front view thereof.
 FIG. 4 is a back view thereof.
 FIG. 5 is a top view thereof.
 FIG. 6 is a bottom view thereof.
 FIG. 7 is a left-side view thereof.
 FIG. 8 is a right-side view thereof.
 FIG. 9 is a left-side perspective view with the sample analyzing section's covers open.
 FIG. 10 is a right-side perspective view with the sample analyzing section's covers open.
 FIG. 11 is a reference view showing the sections of the automated analyzer.
 FIG. 12 is a left-side perspective view of second embodiment of the analyzer showing our new design.
 FIG. 13 is a right-side perspective view thereof.
 FIG. 14 is a front view thereof.
 FIG. 15 is a back view thereof.
 FIG. 16 is a top view thereof.
 FIG. 17 is a bottom view thereof.
 FIG. 18 is a left-side view thereof.
 FIG. 19 is a right-side view thereof.
 FIG. 20 is a left-side perspective view with the sample analyzing section's covers open.
 FIG. 21 is a right-side perspective view with the sample analyzing section's covers open.
 FIG. 22 is a reference view showing the sections of the automated analyzer.
 FIG. 23 is a left-side perspective view of a third embodiment of the automated analyzer showing our new design.
 FIG. 24 is a right-side perspective view thereof.
 FIG. 25 is a front view thereof.
 FIG. 26 is a back view thereof.
 FIG. 27 is a top view thereof.
 FIG. 28 is a bottom view thereof.
 FIG. 29 is a left-side view thereof.
 FIG. 30 is a right-side view thereof.
 FIG. 31 is a left-side perspective view with the sample analyzing section's covers open.
 FIG. 32 is a right-side perspective view with the sample analyzing section's covers open; and,
 FIG. 33 is a reference view showing the sections of the automated analyzer.

1 Claim, 16 Drawing Sheets

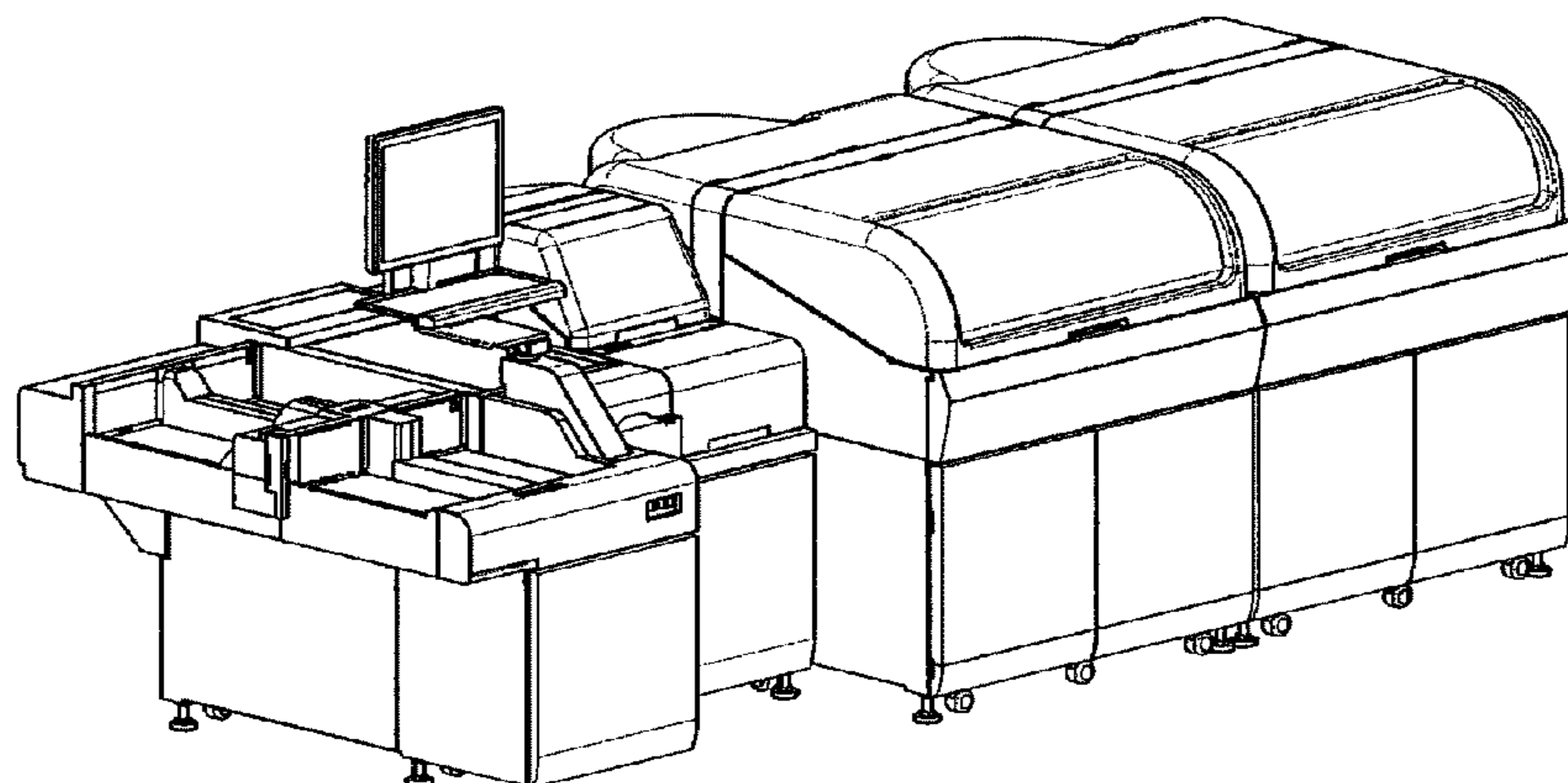

US D645,367 S

Page 2

U.S. PATENT DOCUMENTS

D303,095 S *	8/1989	Nagai et al.	D10/81	D354,354 S *	1/1995	Yamashita et al.	D24/186
D304,307 S *	10/1989	Nagai et al.	D10/81	7,931,861 B2 *	4/2011	Kitagawa	422/63
D338,419 S *	8/1993	Frenkel et al.	D10/81	7,943,383 B2 *	5/2011	Uchihashi et al.	436/63

* cited by examiner

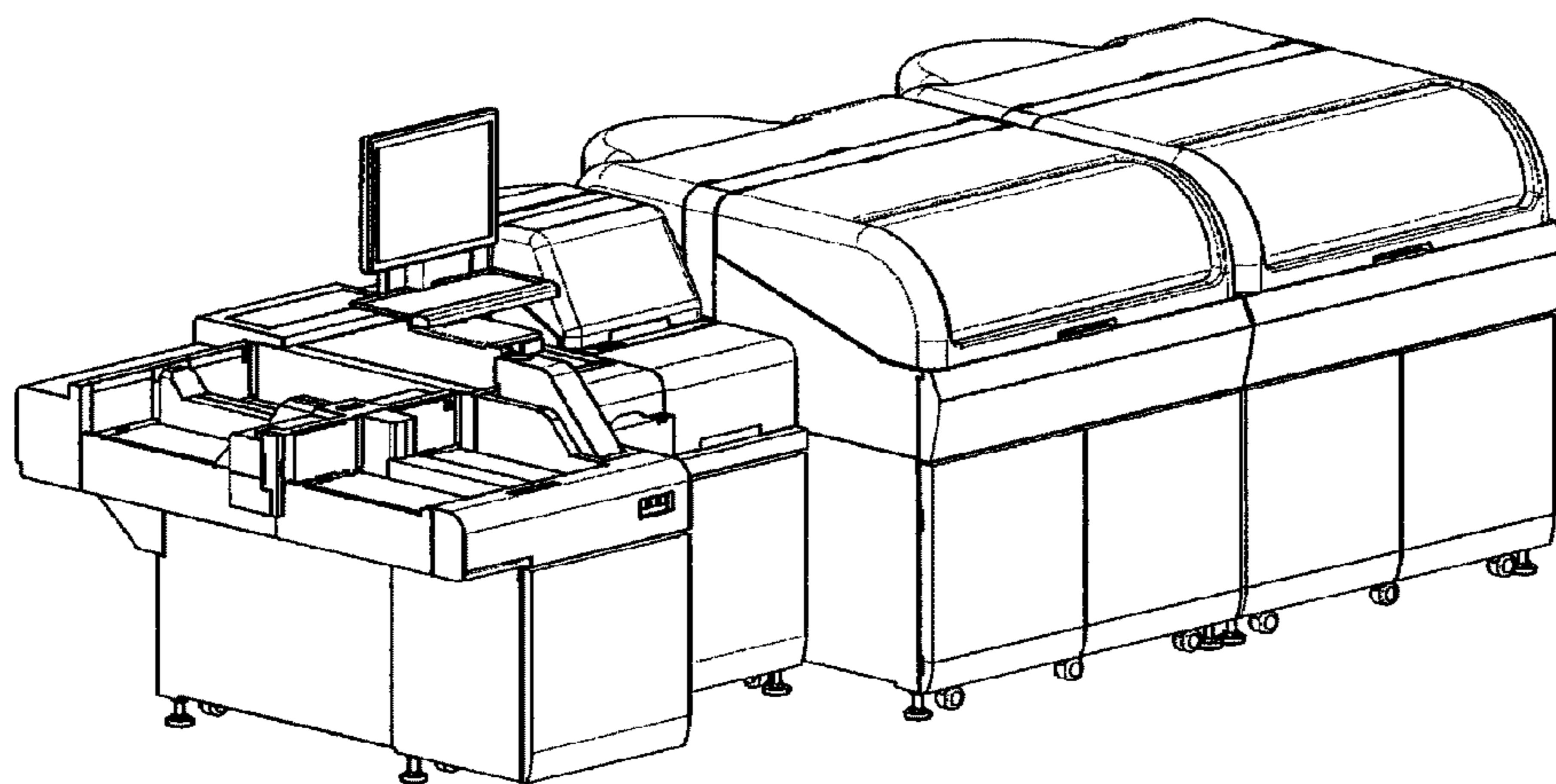

FIG. 1

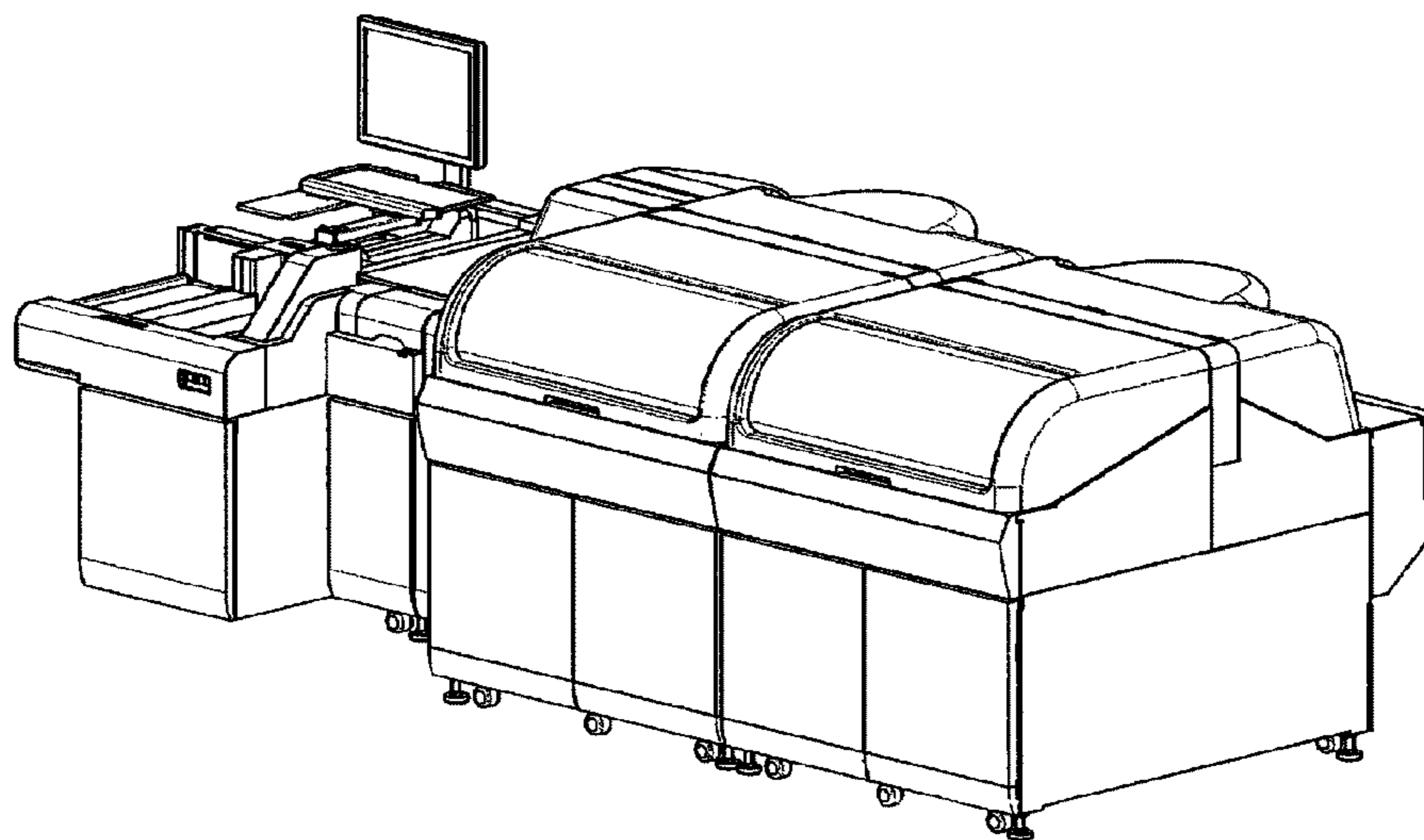

FIG. 2

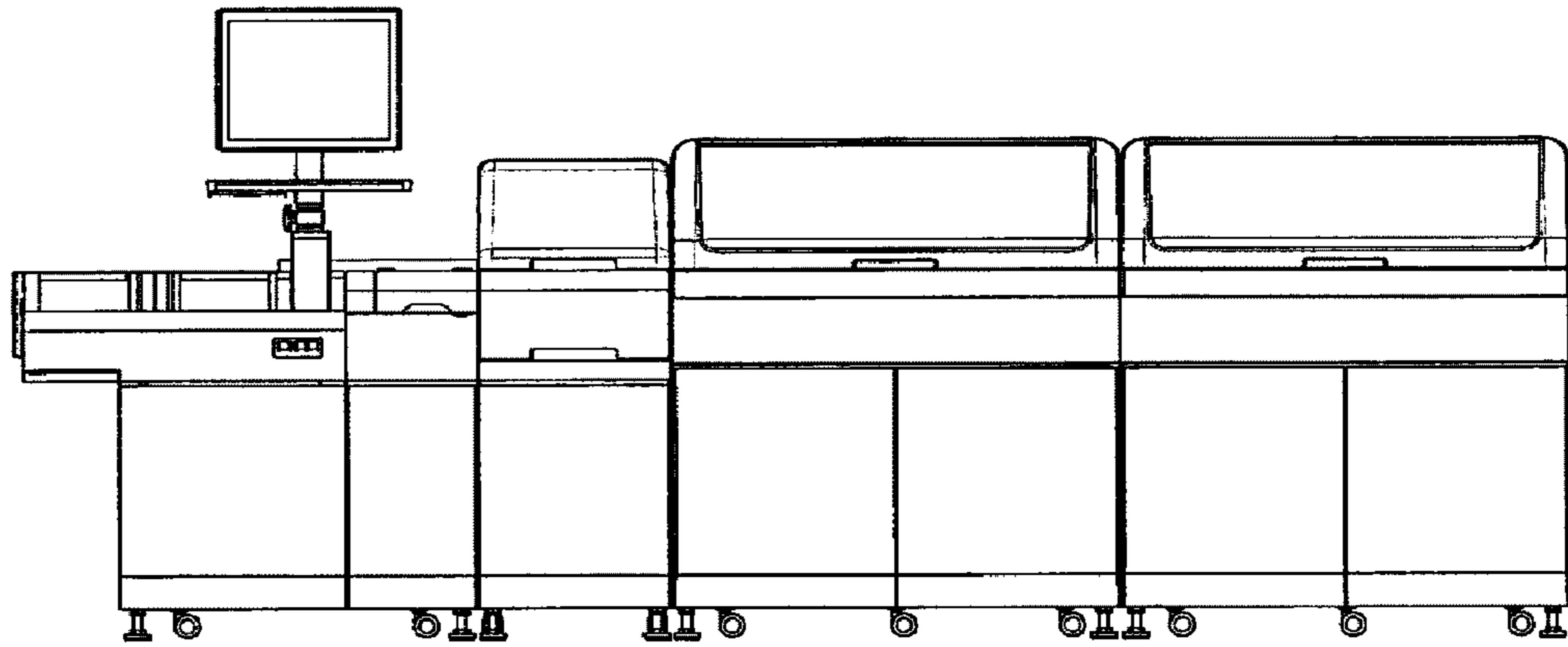

FIG. 3

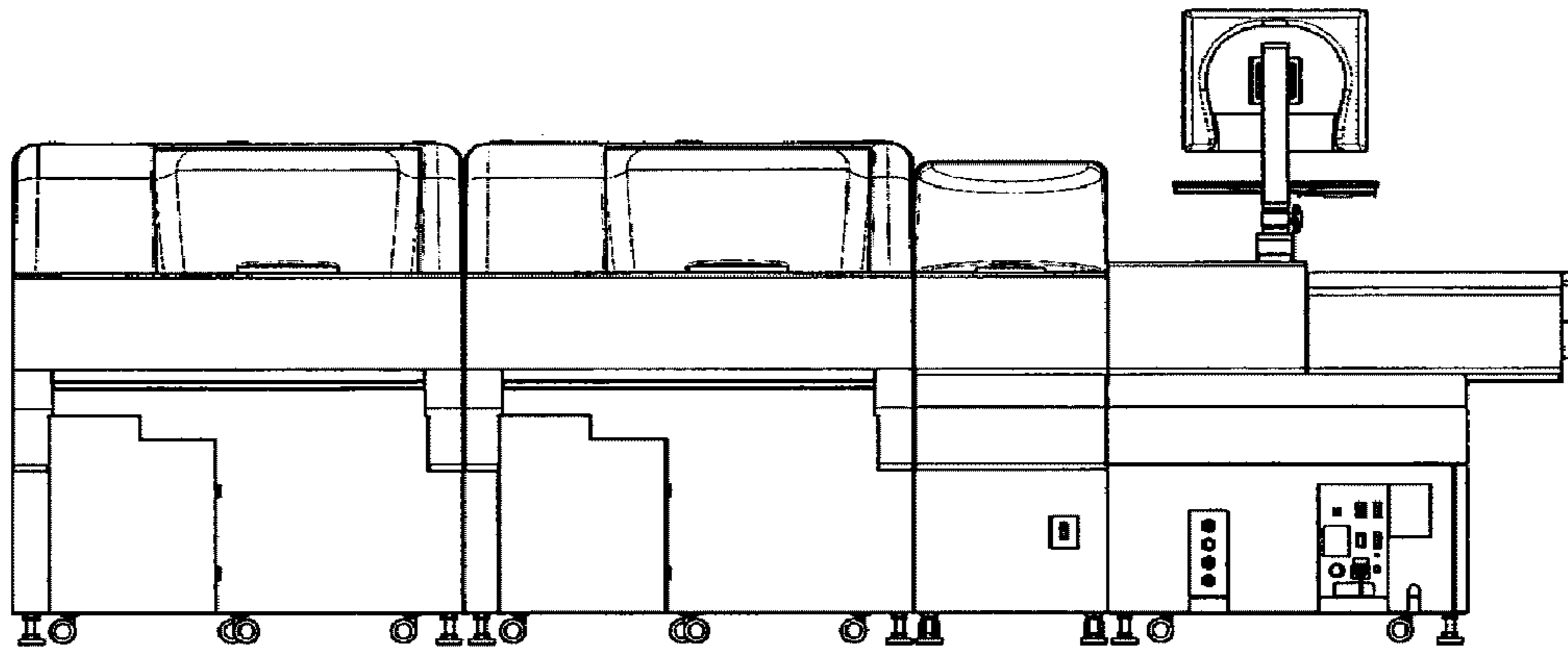

FIG. 4

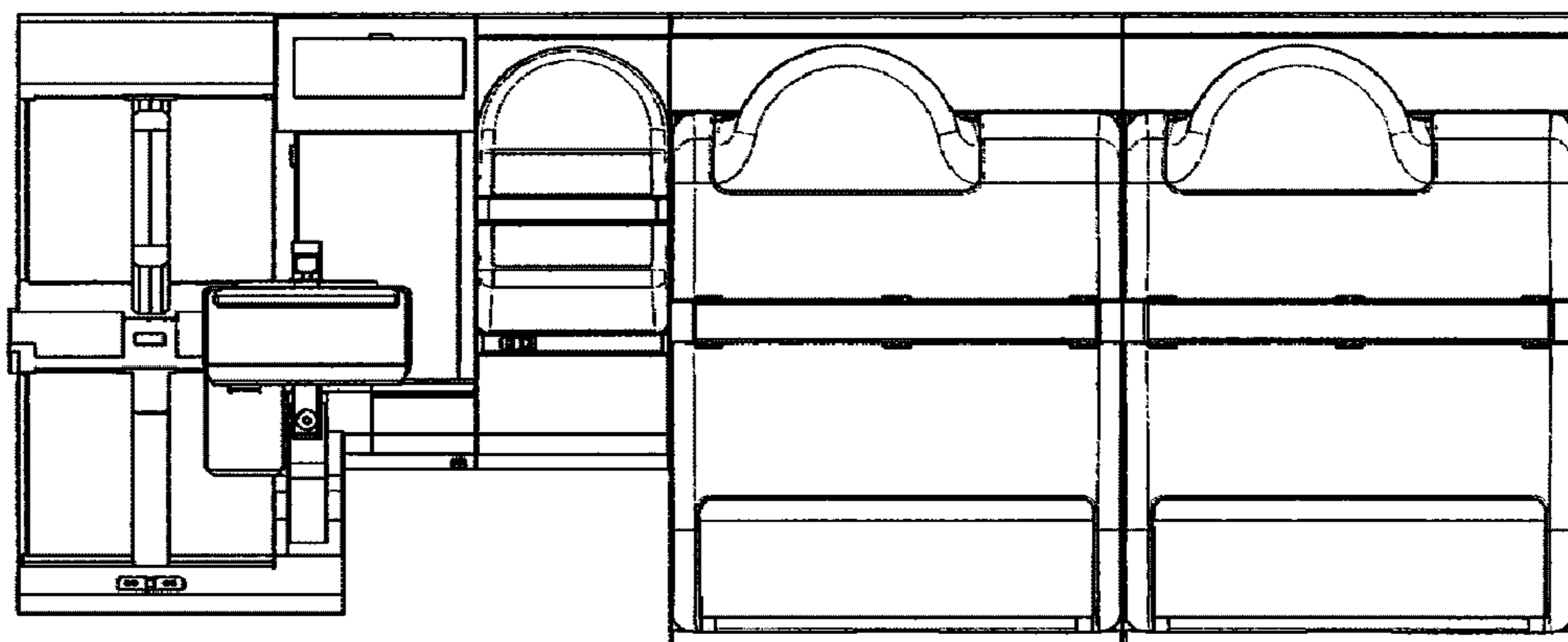

FIG. 5

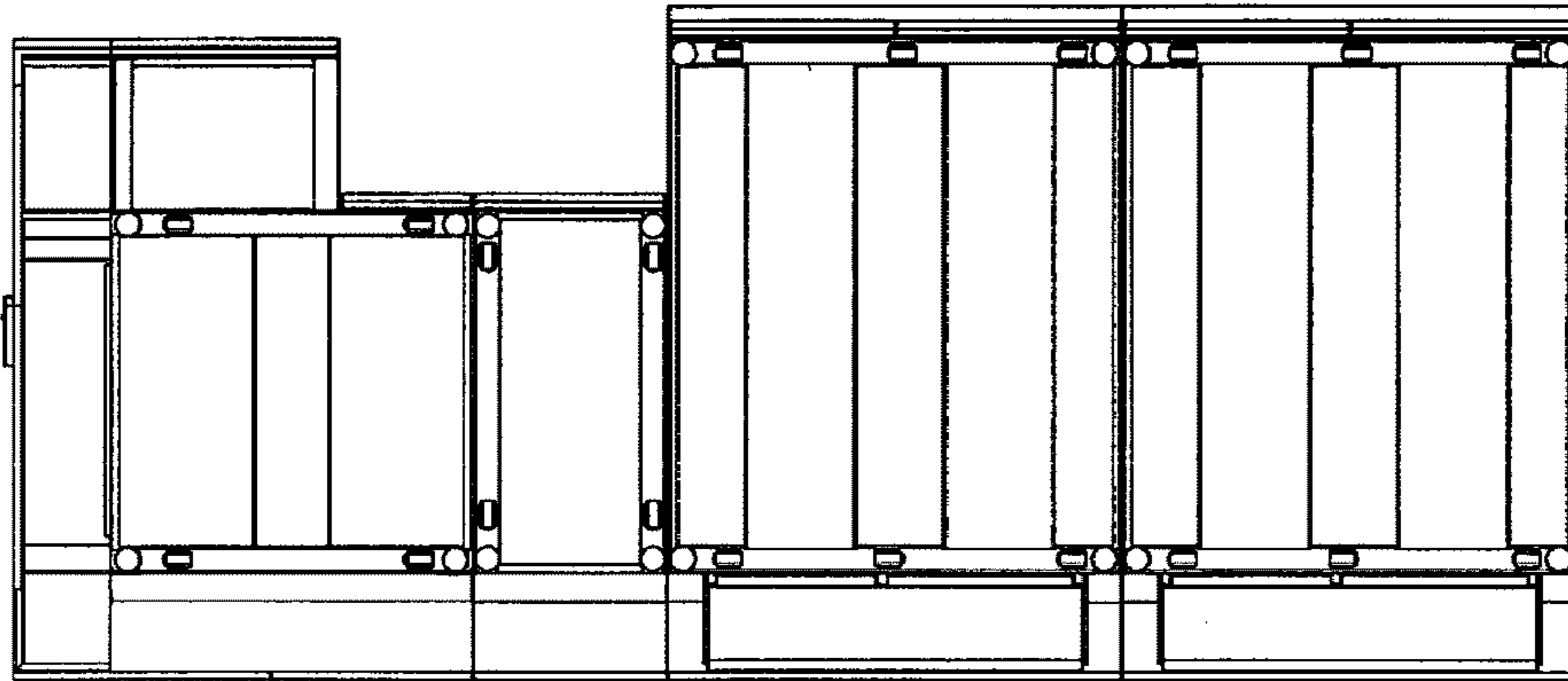

FIG. 6

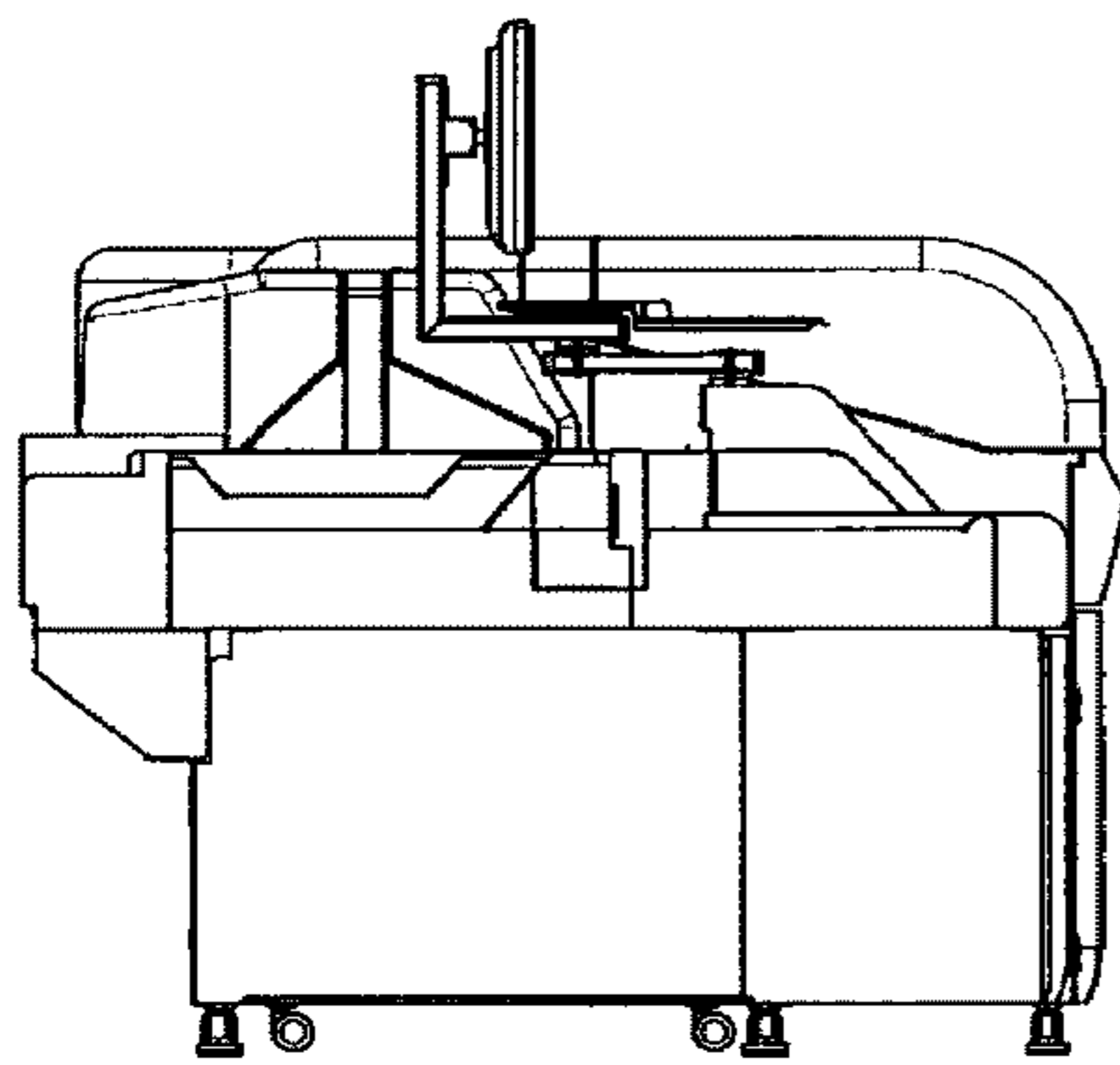

FIG. 7

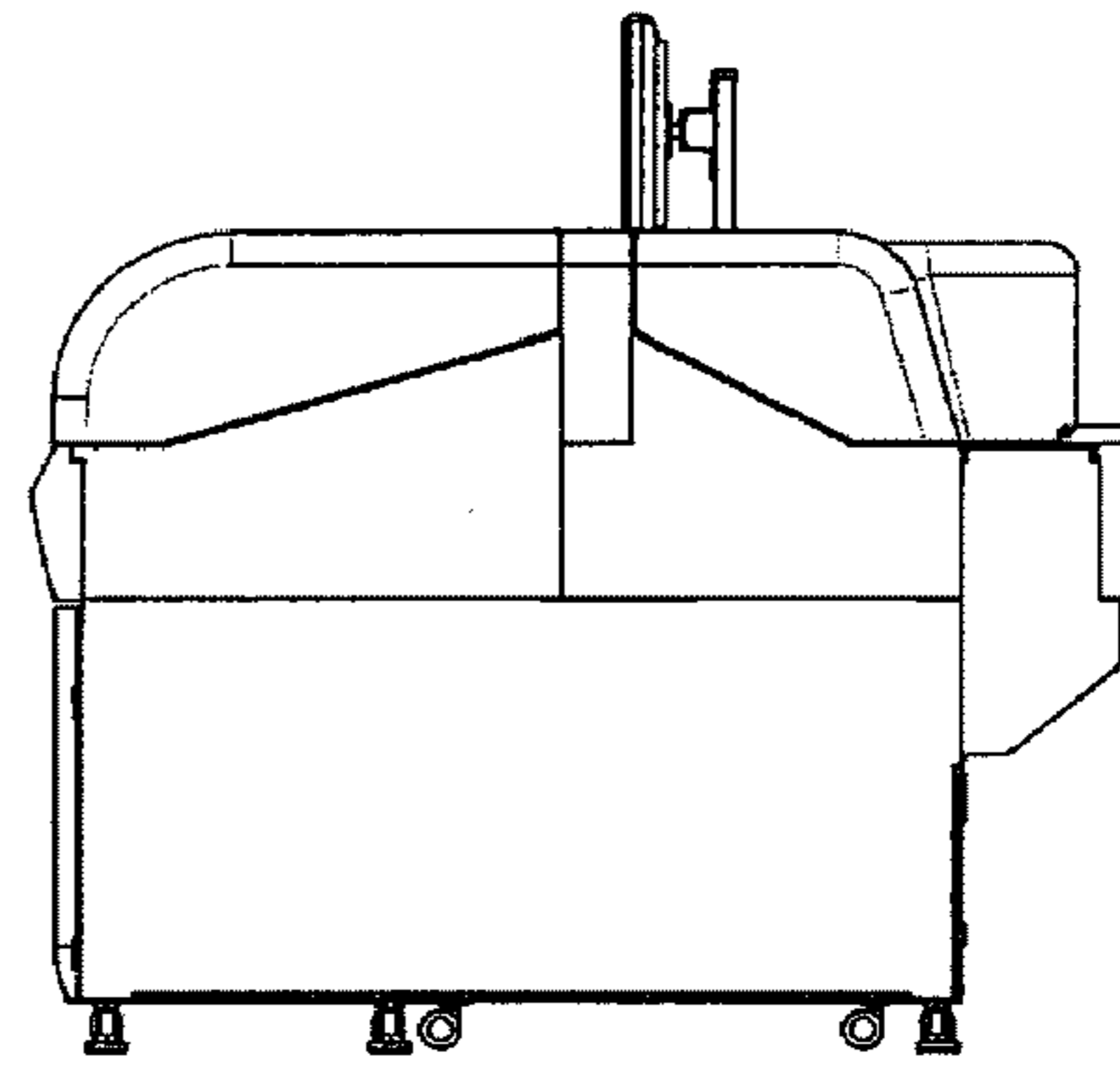

FIG. 8

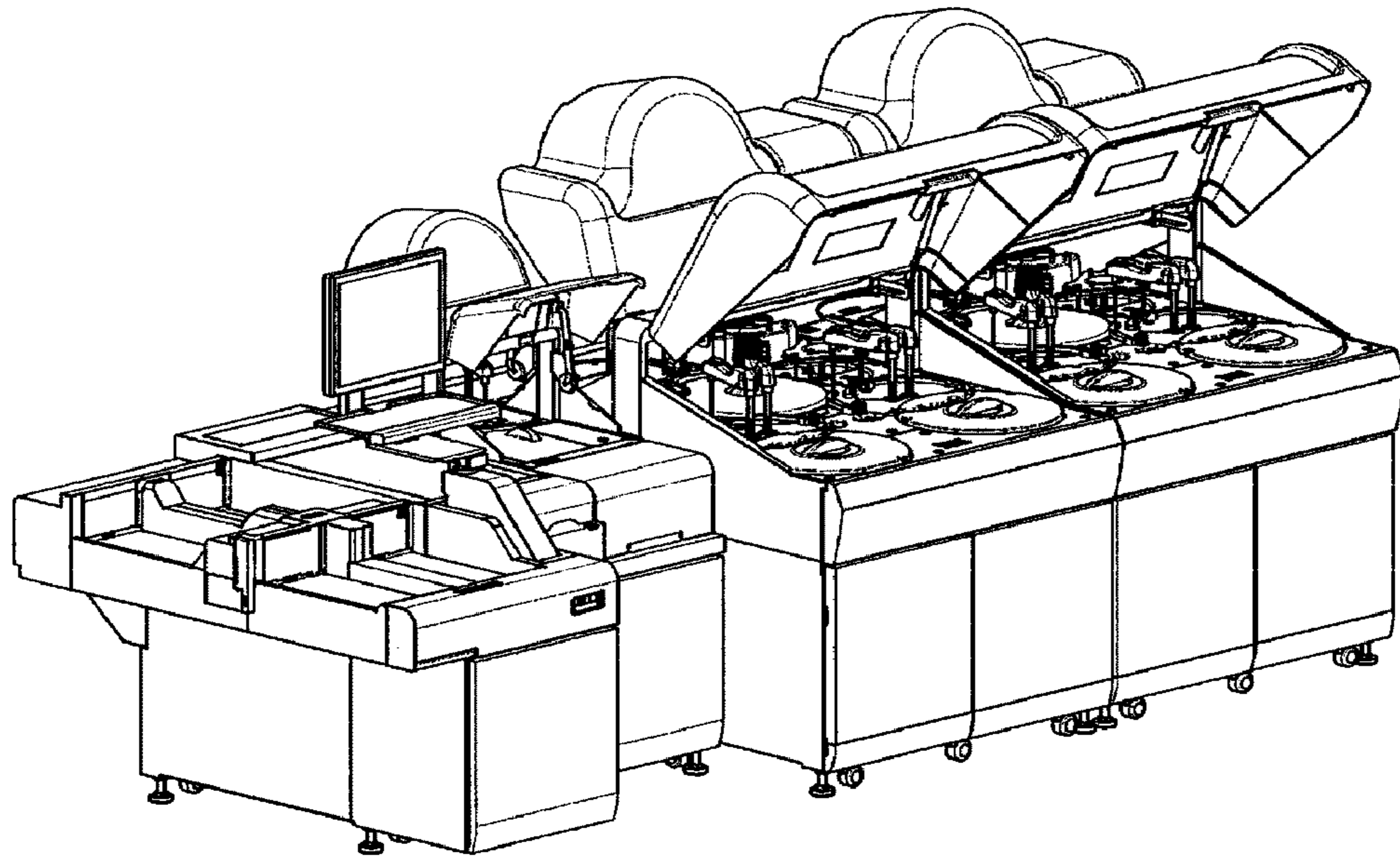

FIG. 9

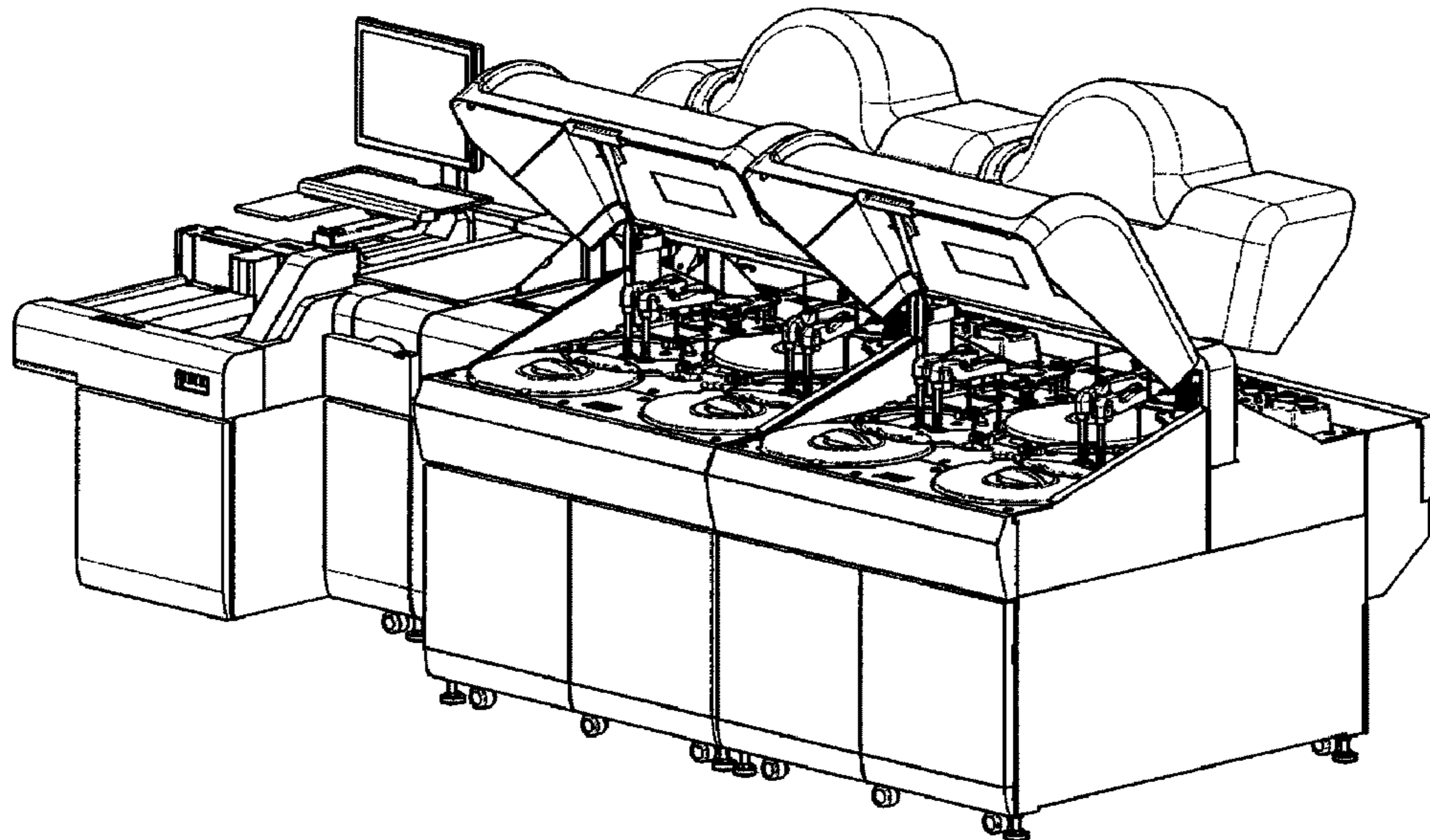

FIG. 10

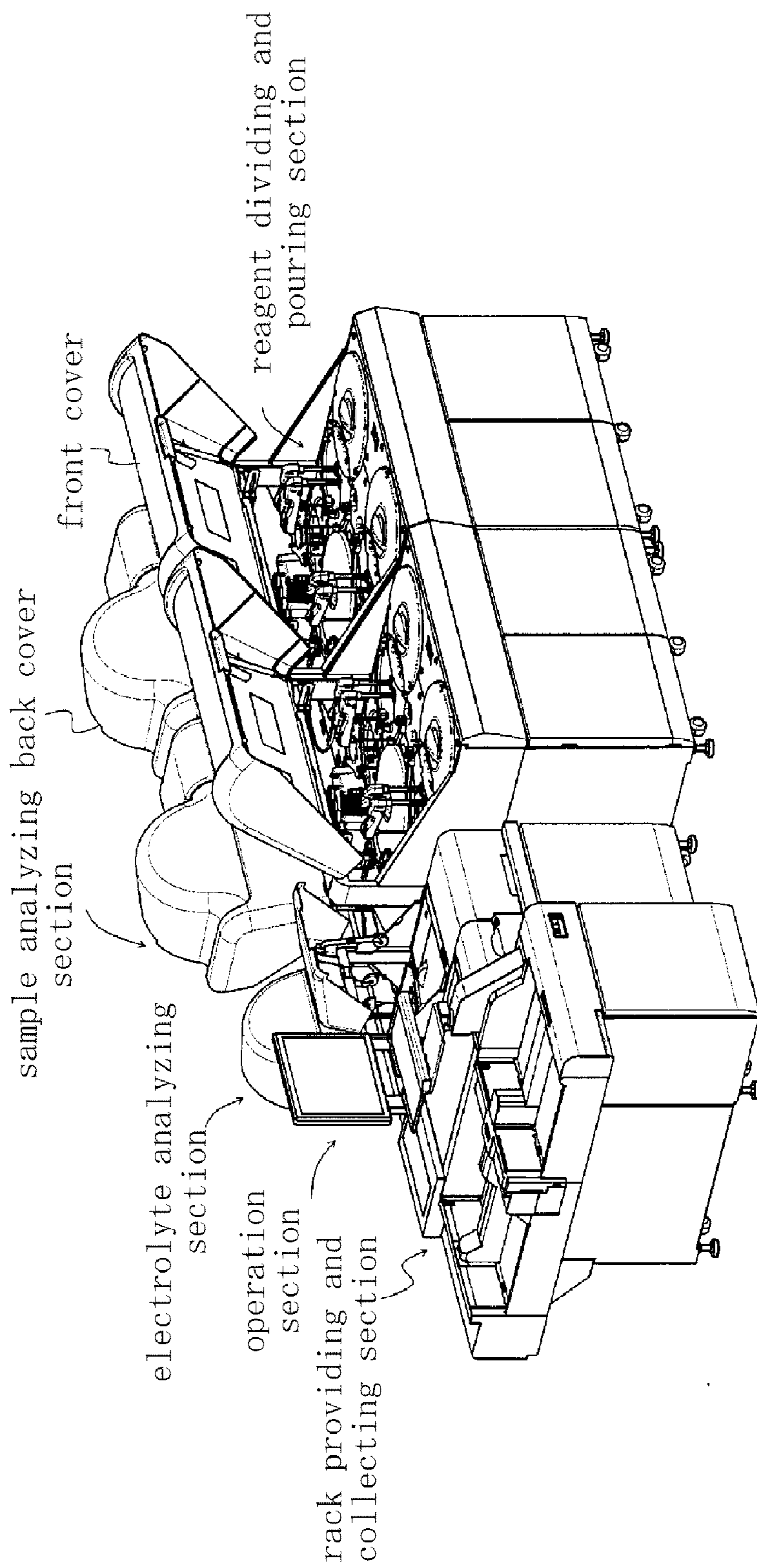

FIG. 11

FIG. 12

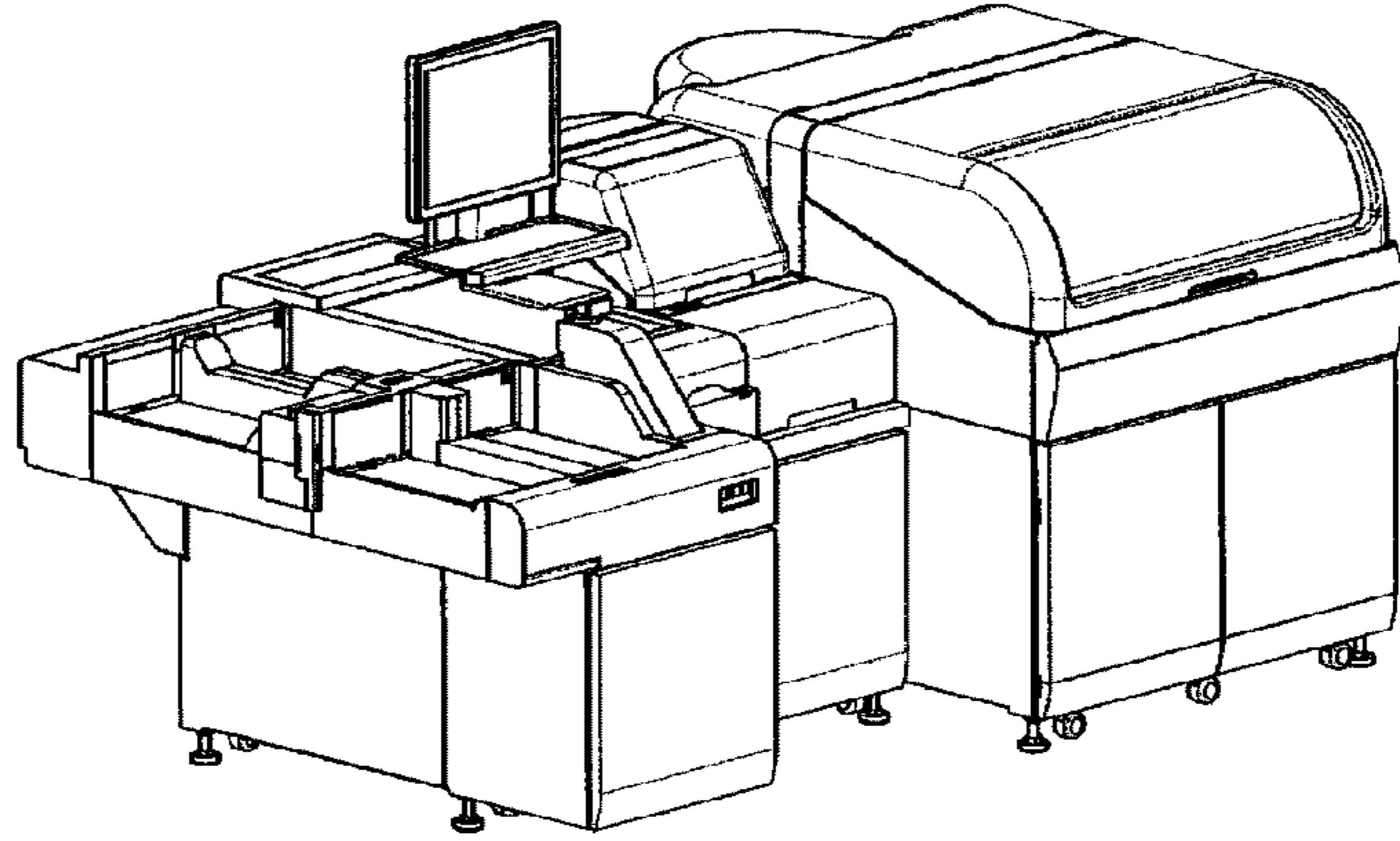

FIG. 13

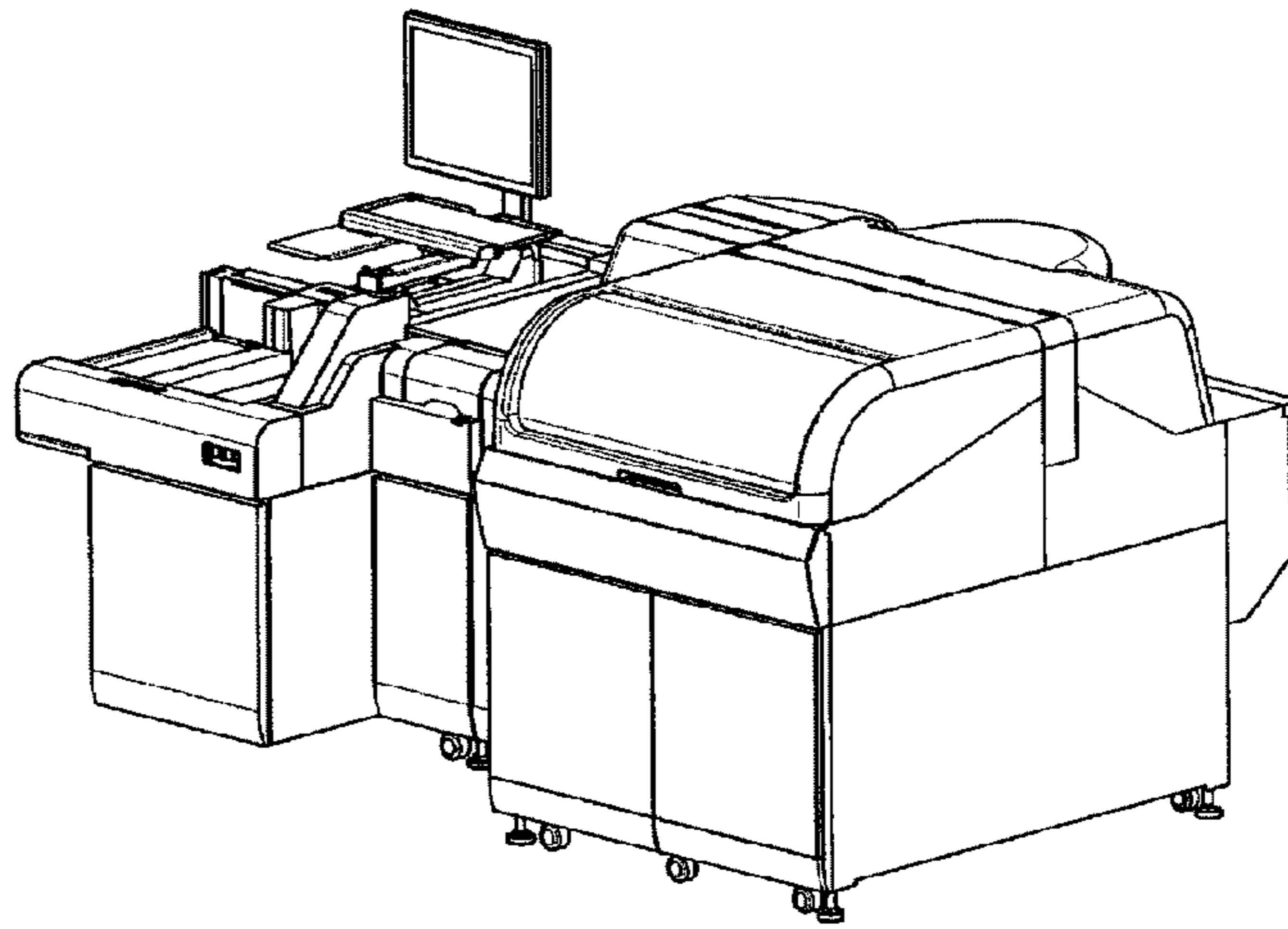

FIG. 14

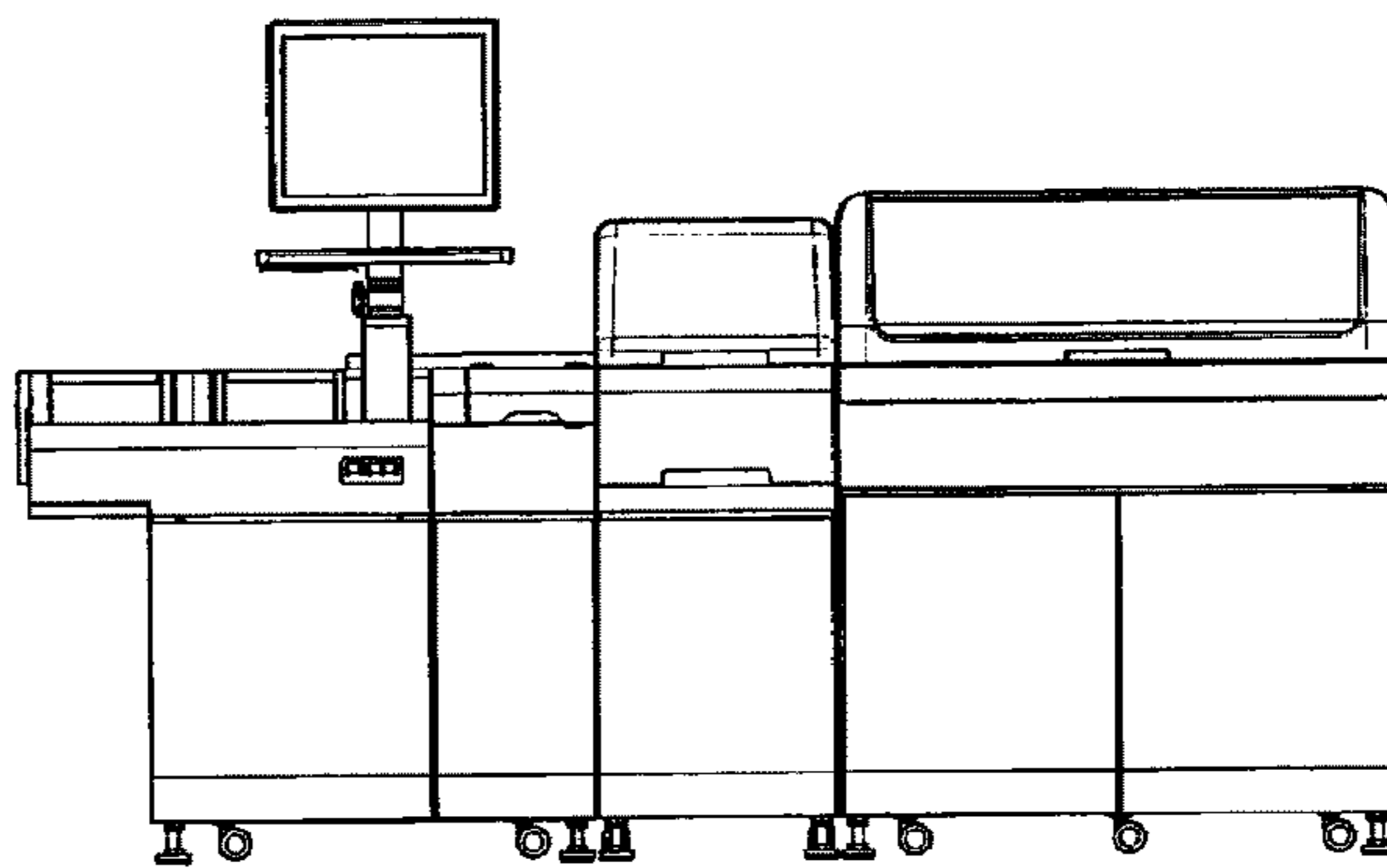

FIG. 15

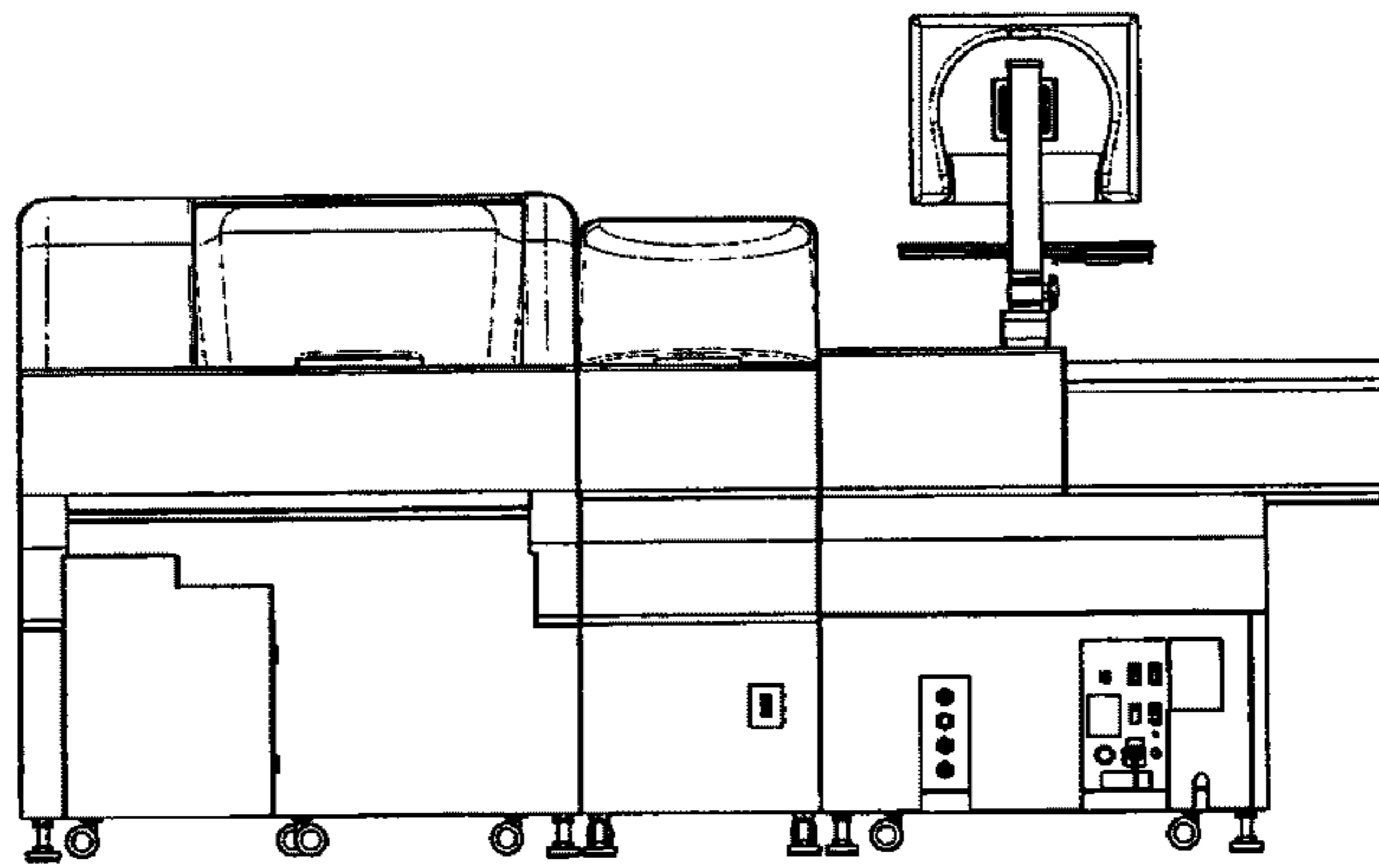

FIG. 16

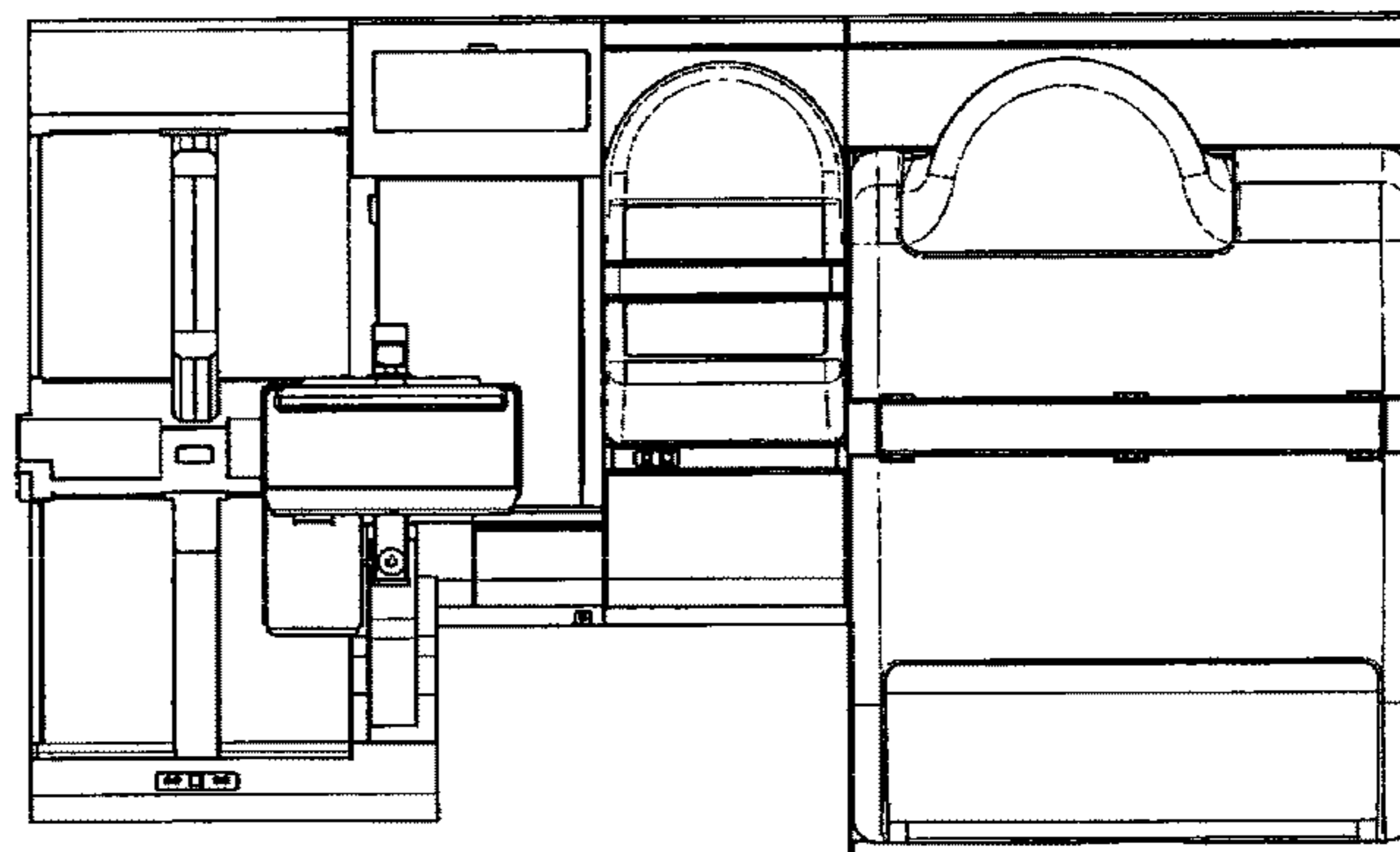
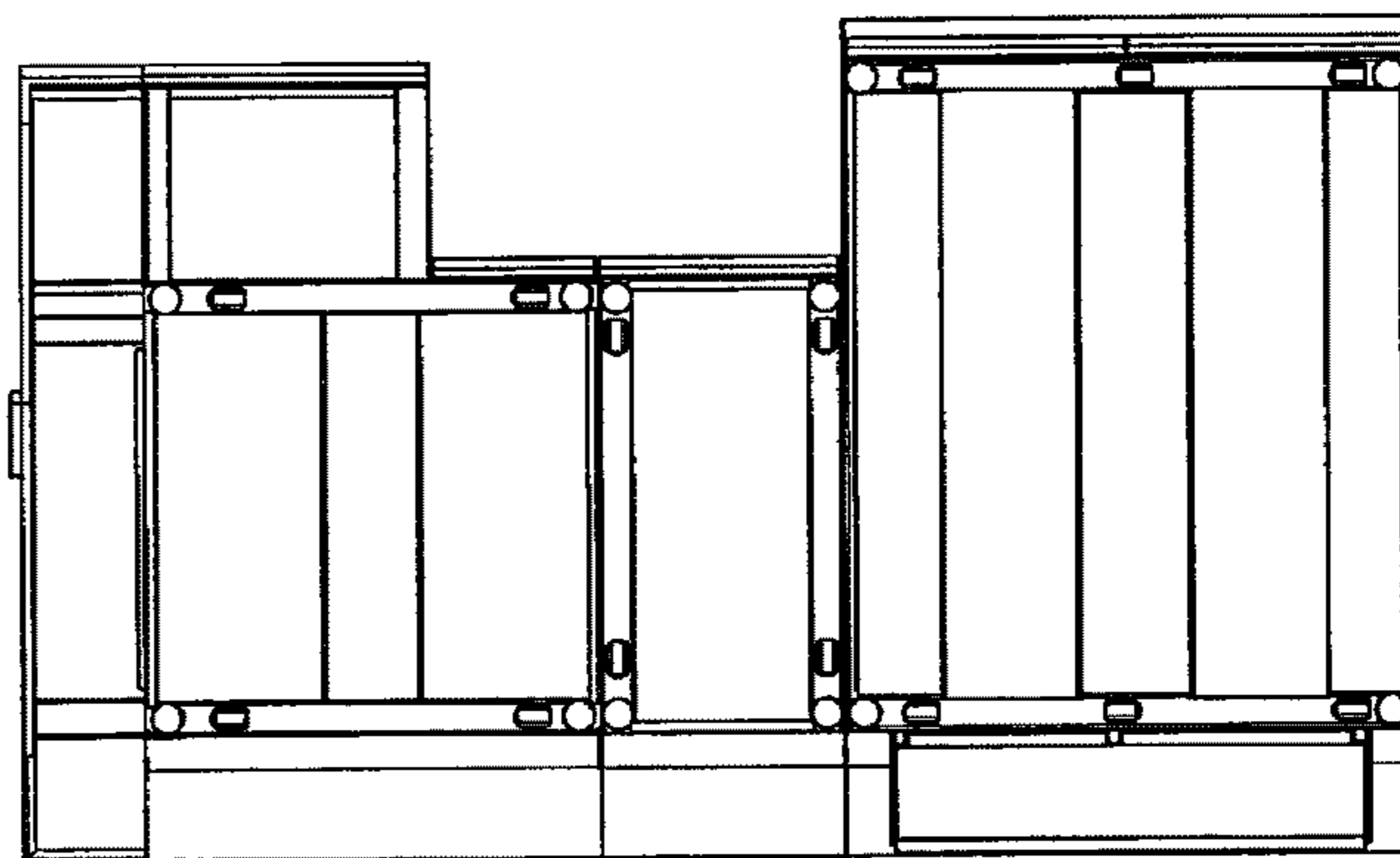

FIG. 17



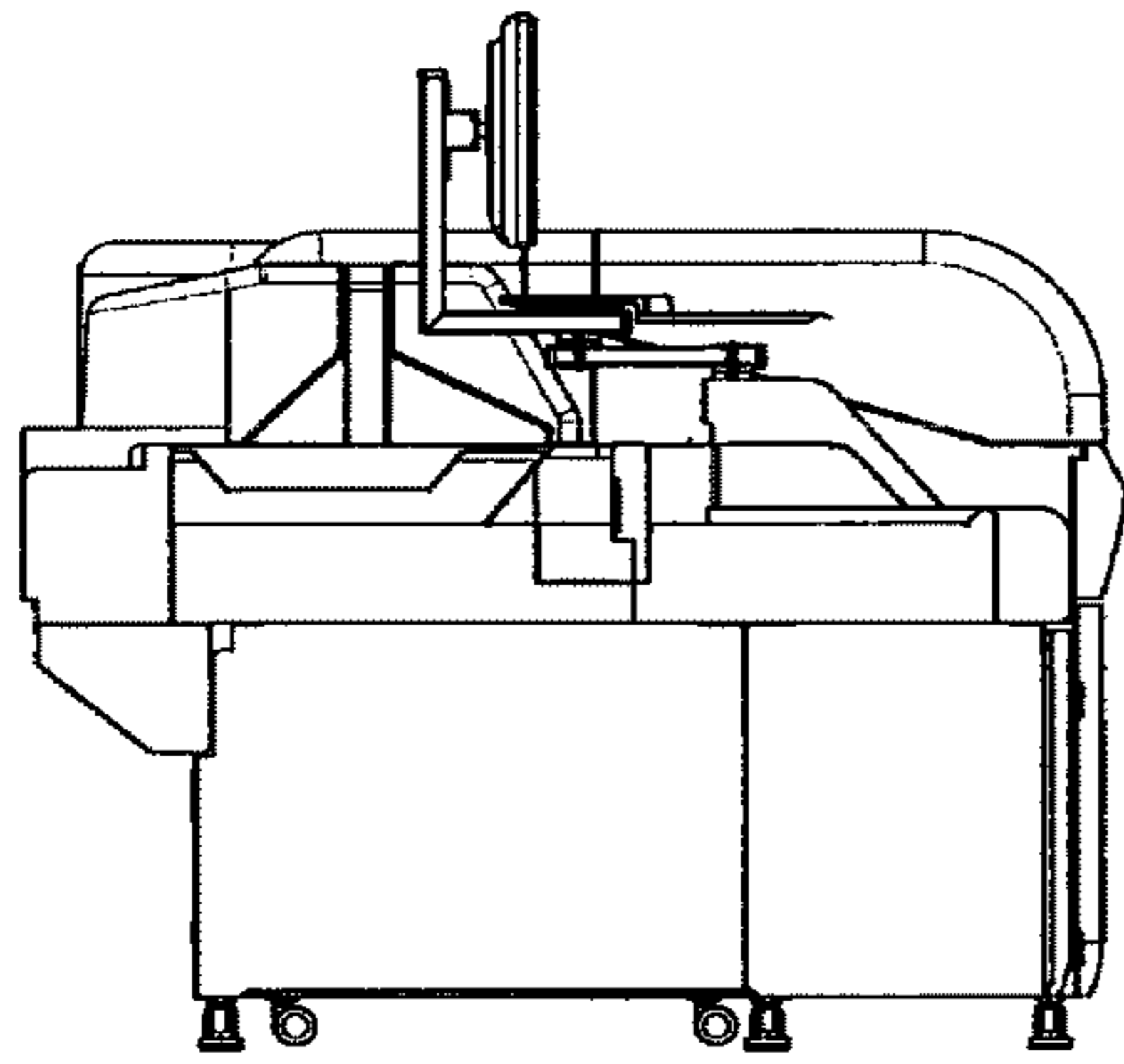

FIG. 18

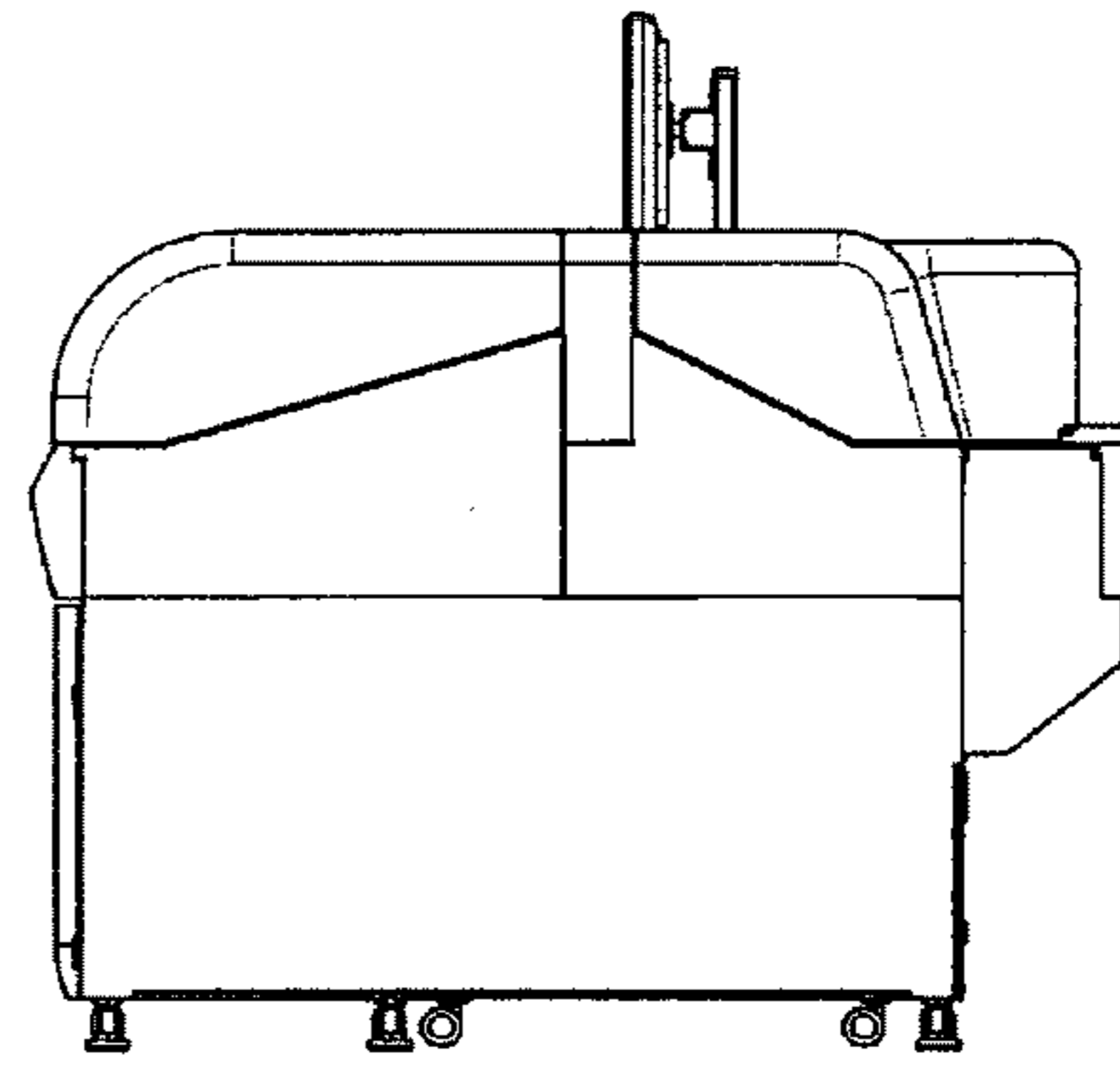

FIG. 19

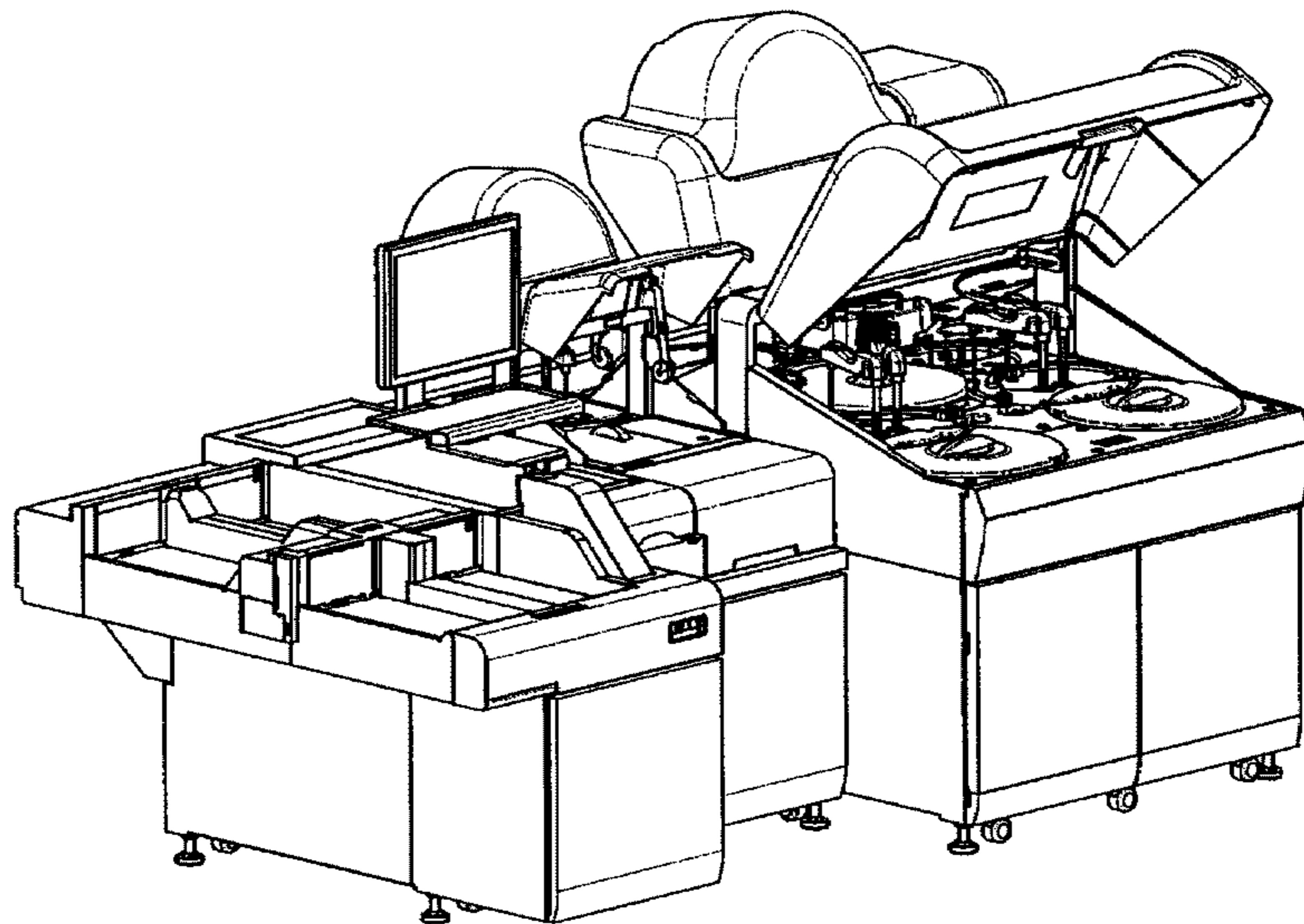

FIG. 20

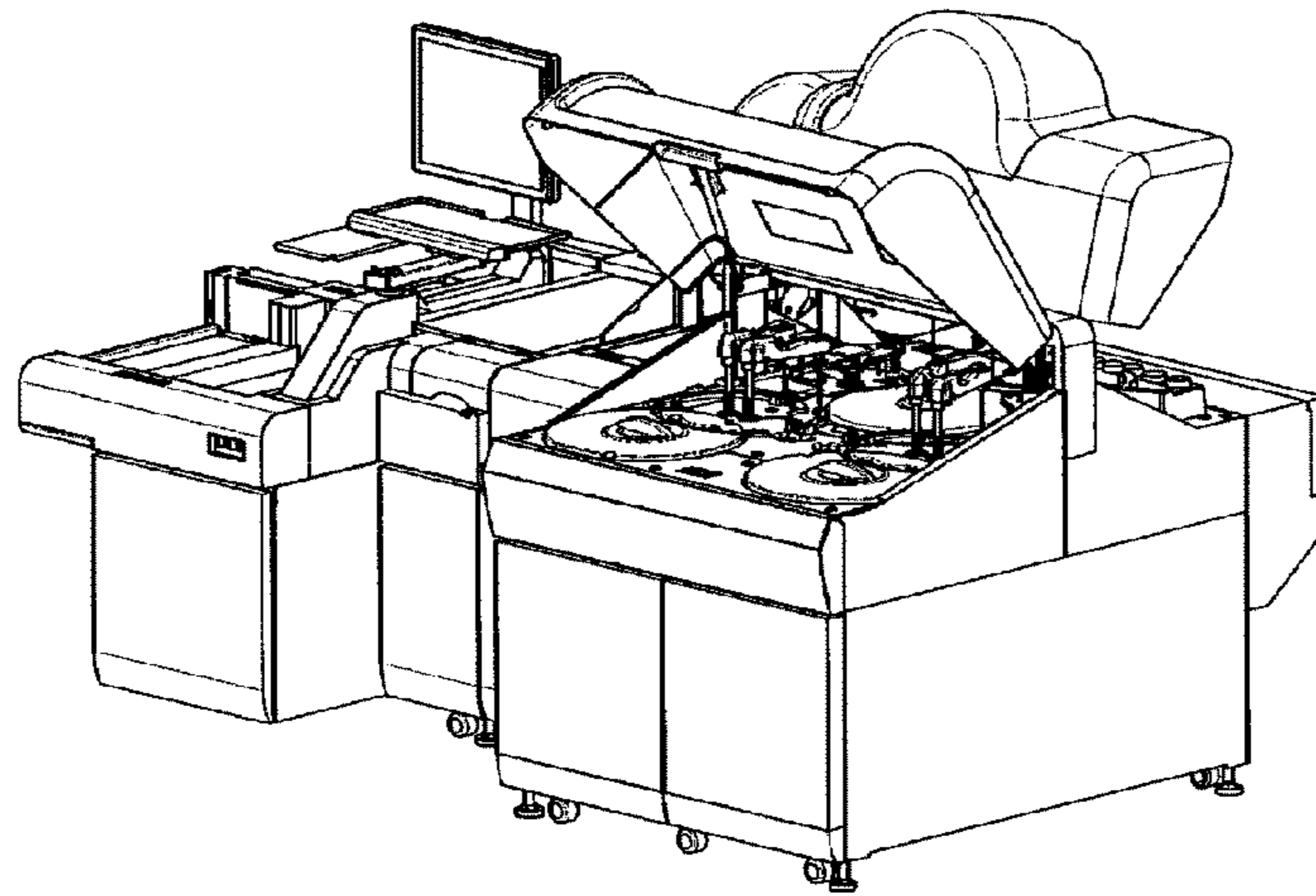

FIG. 21

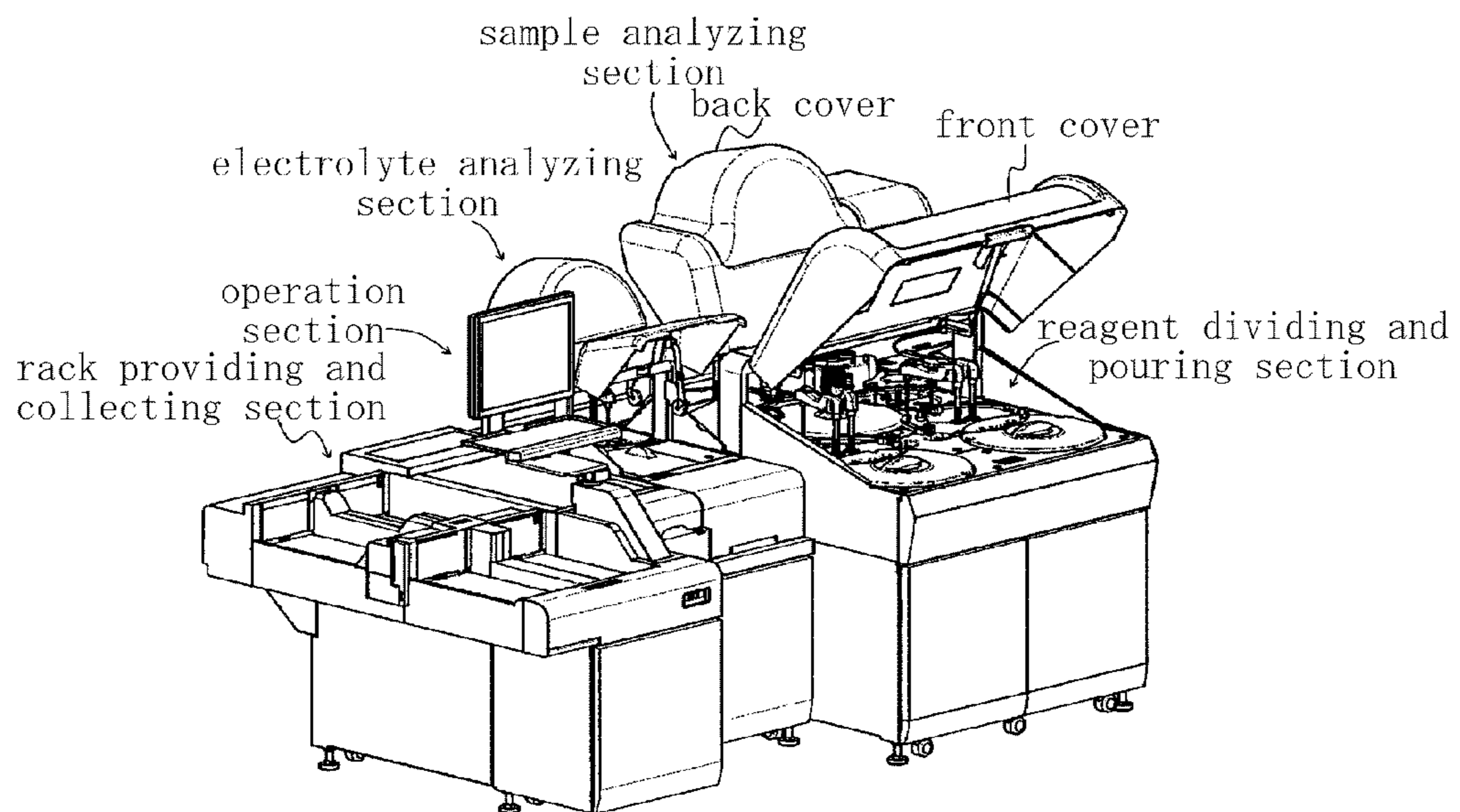

FIG. 22

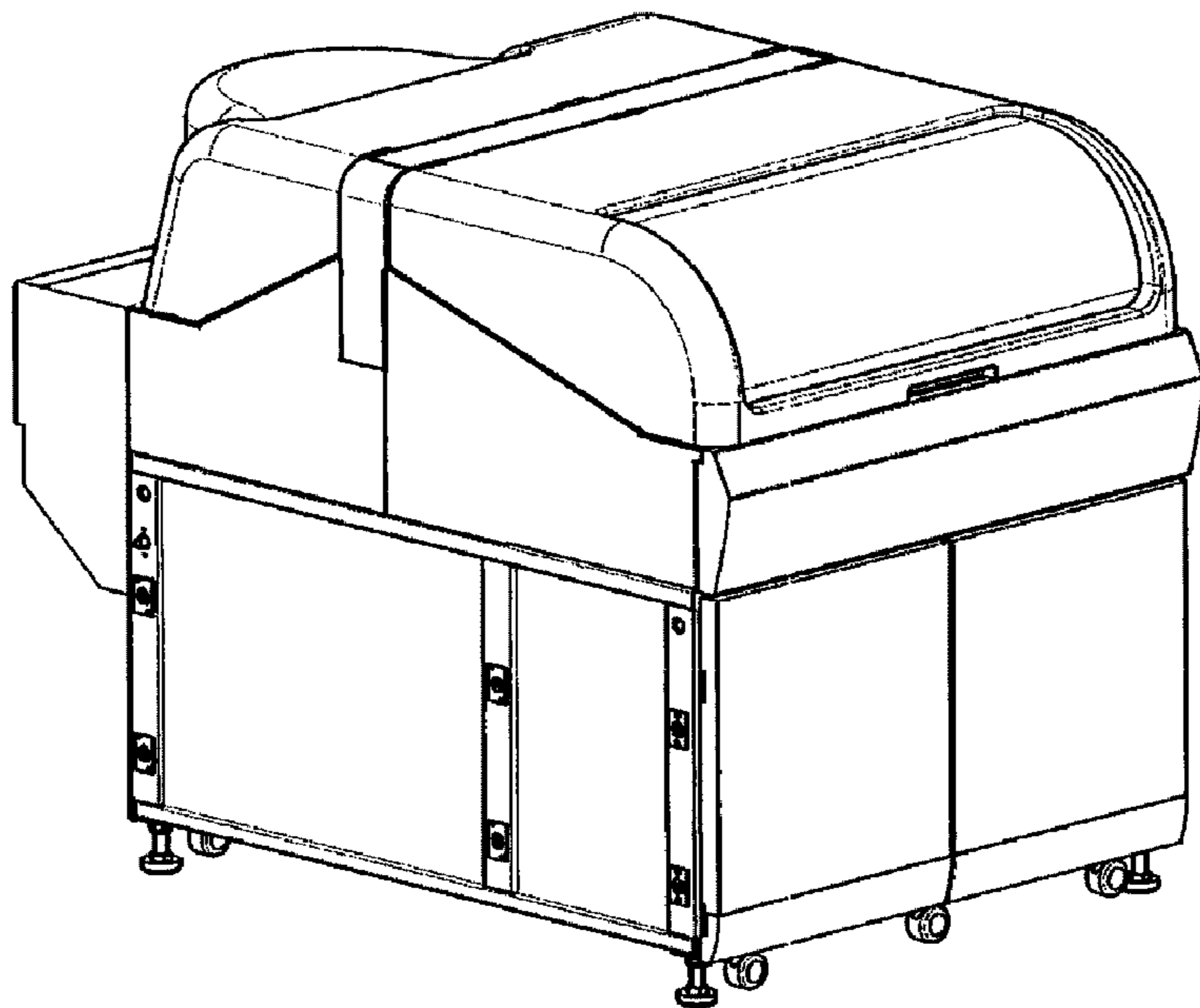

FIG. 23

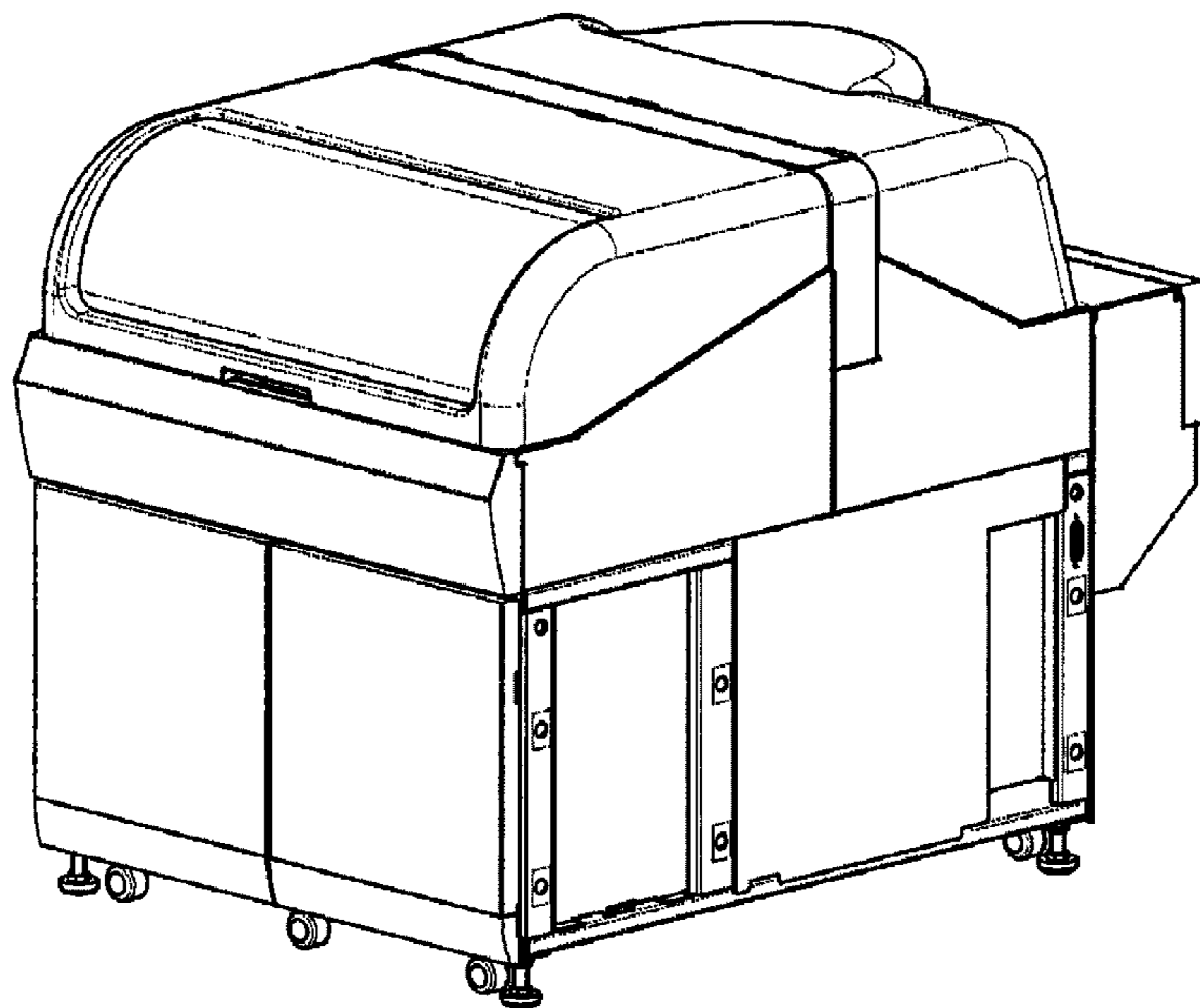

FIG. 24

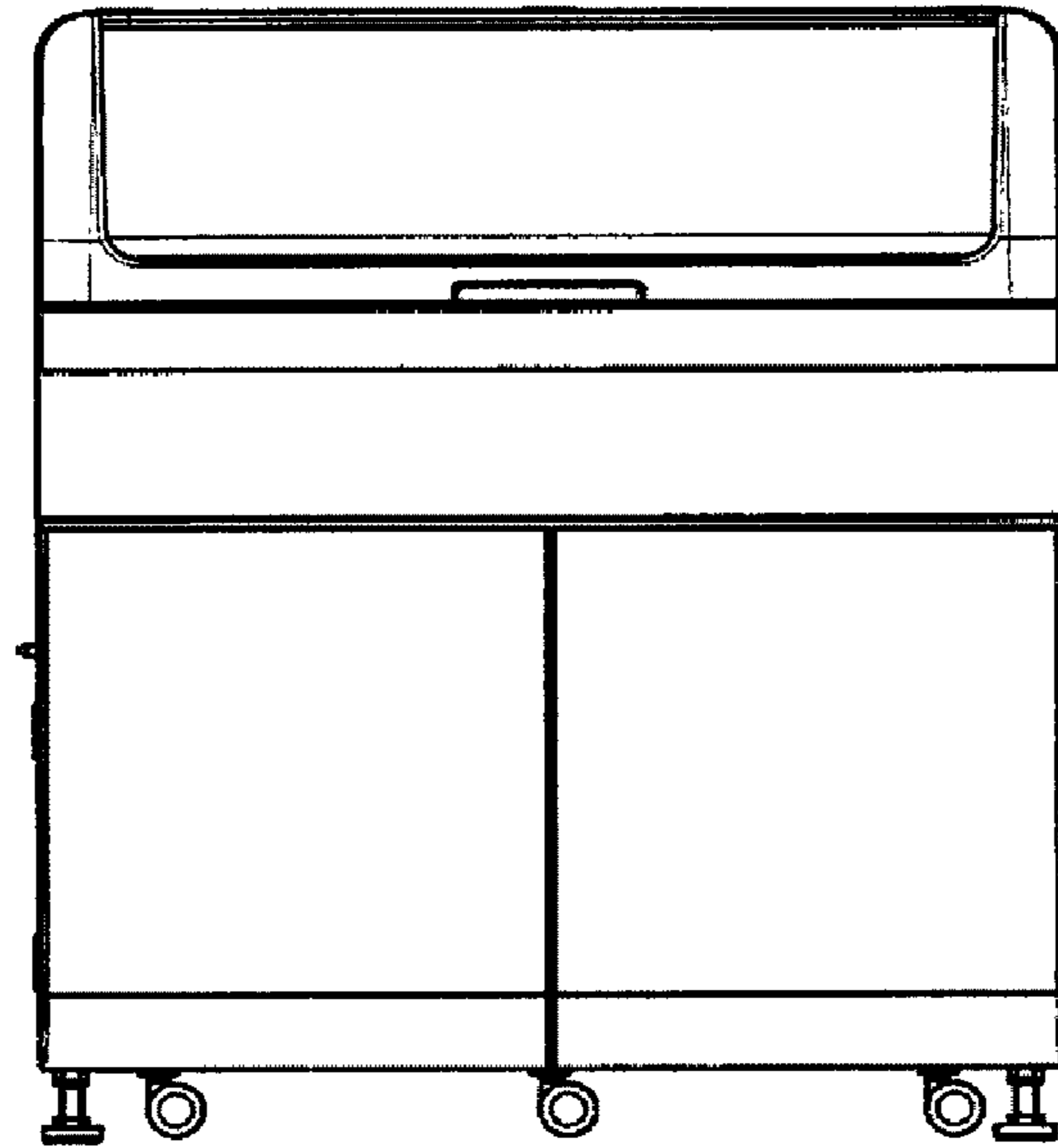

FIG. 25

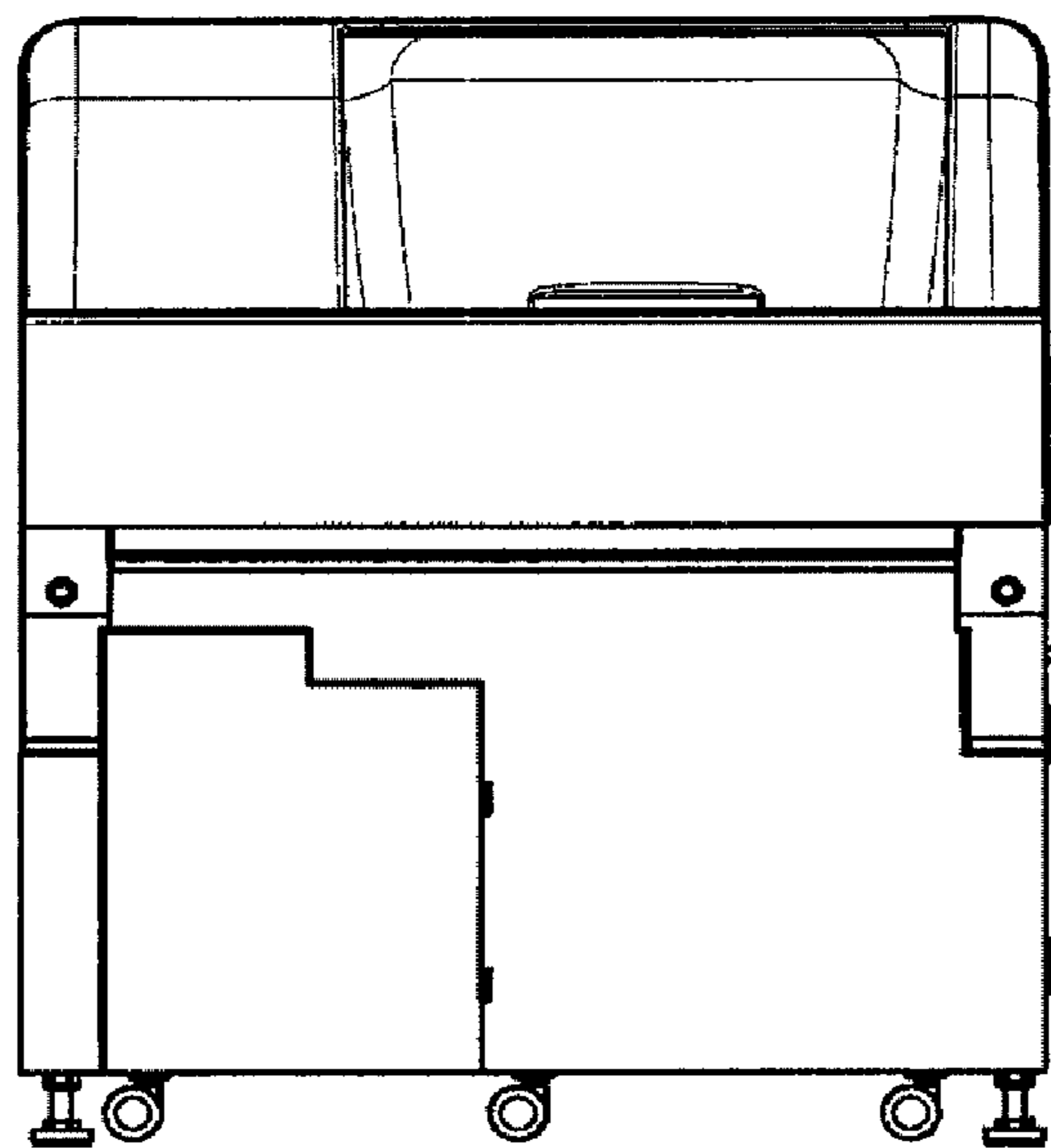

FIG. 26

FIG. 27

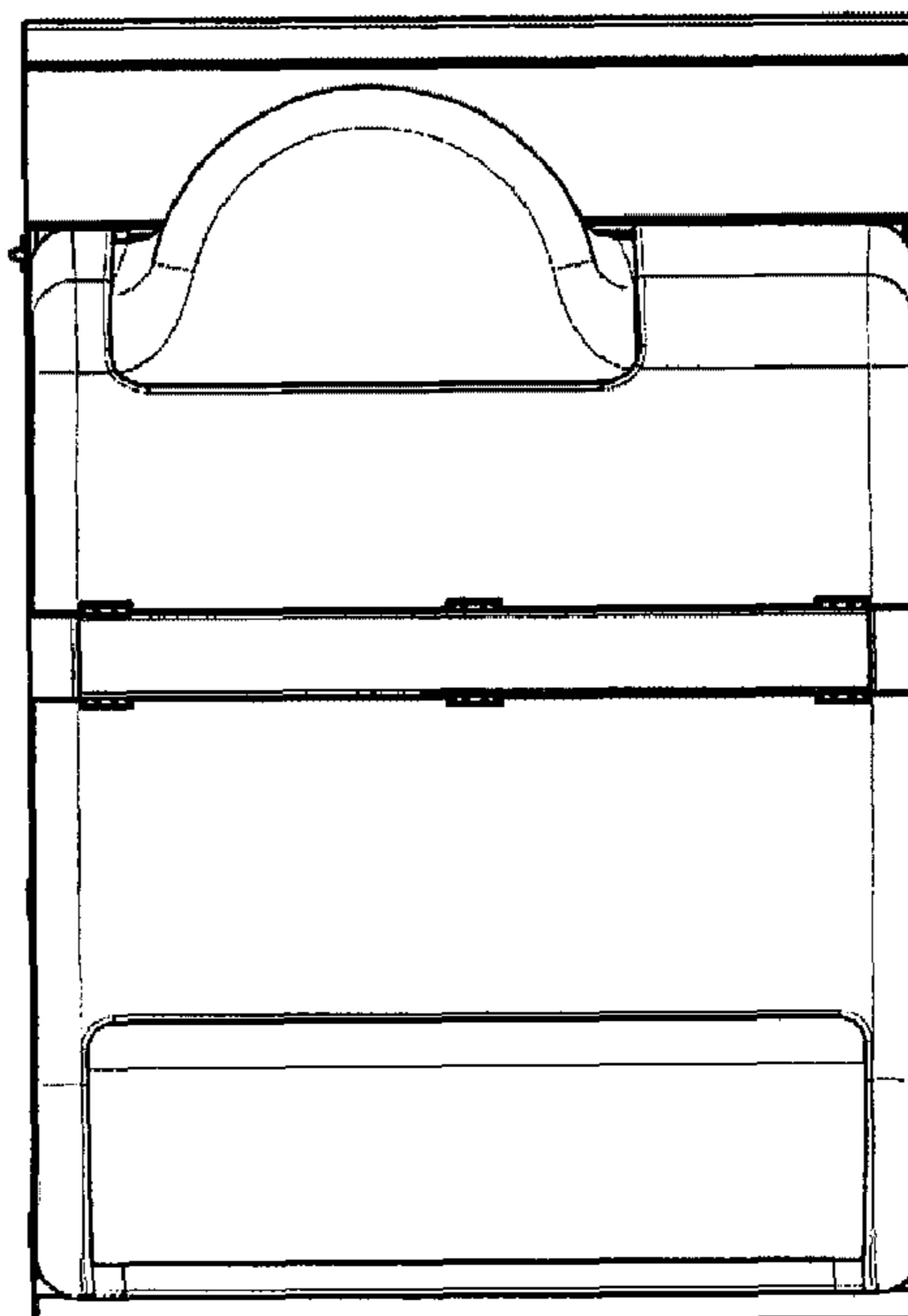
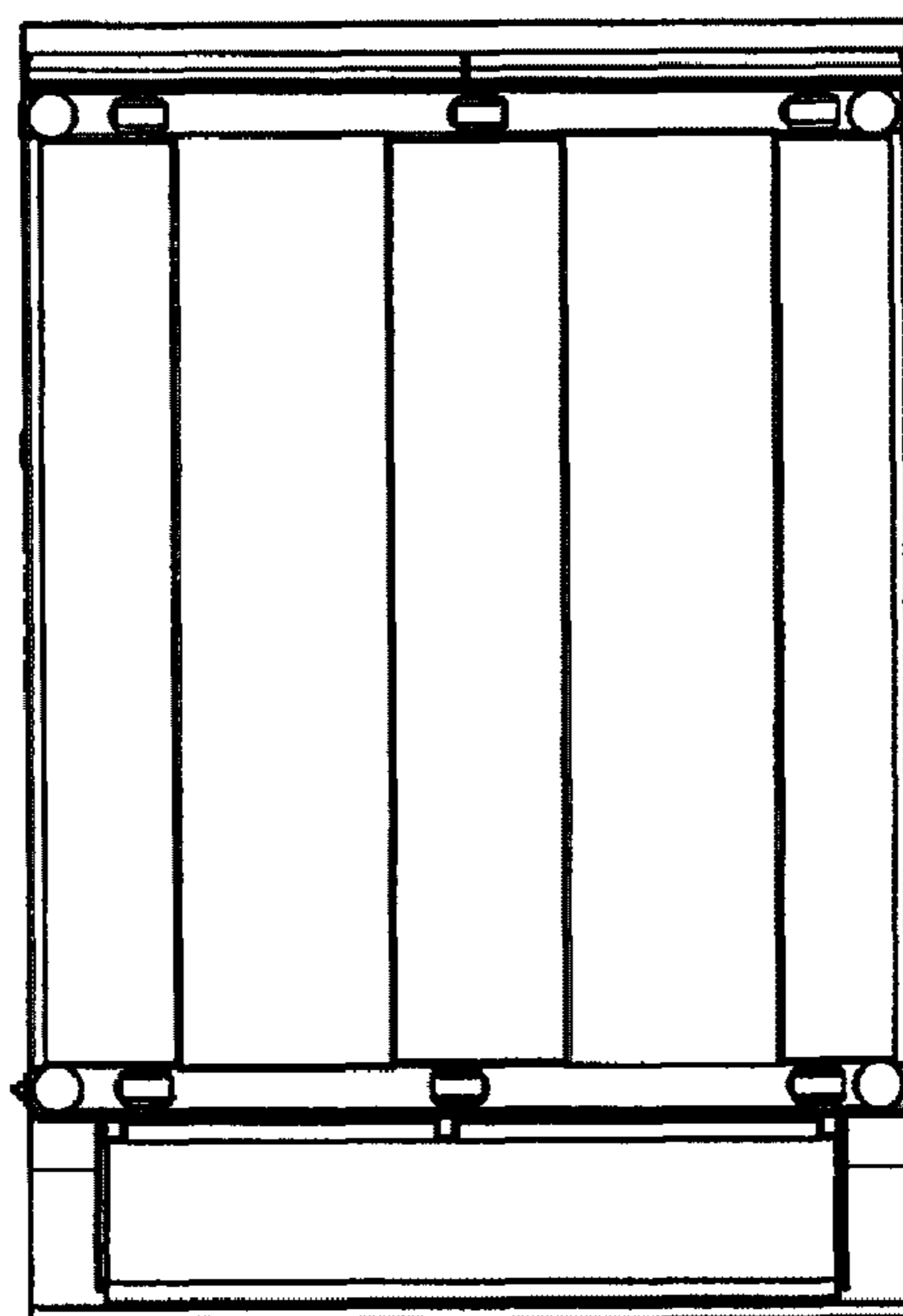

FIG. 28



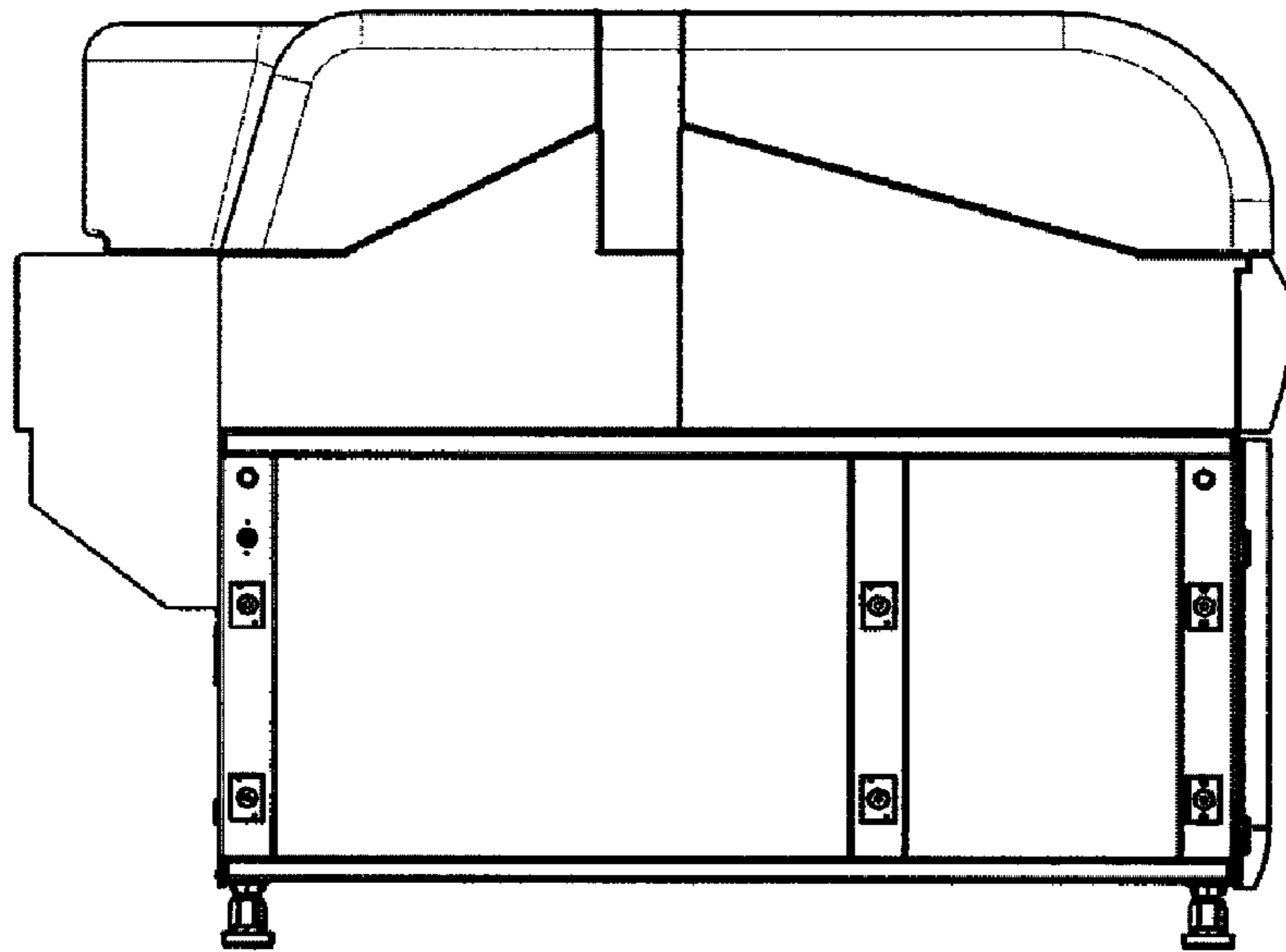

FIG. 29

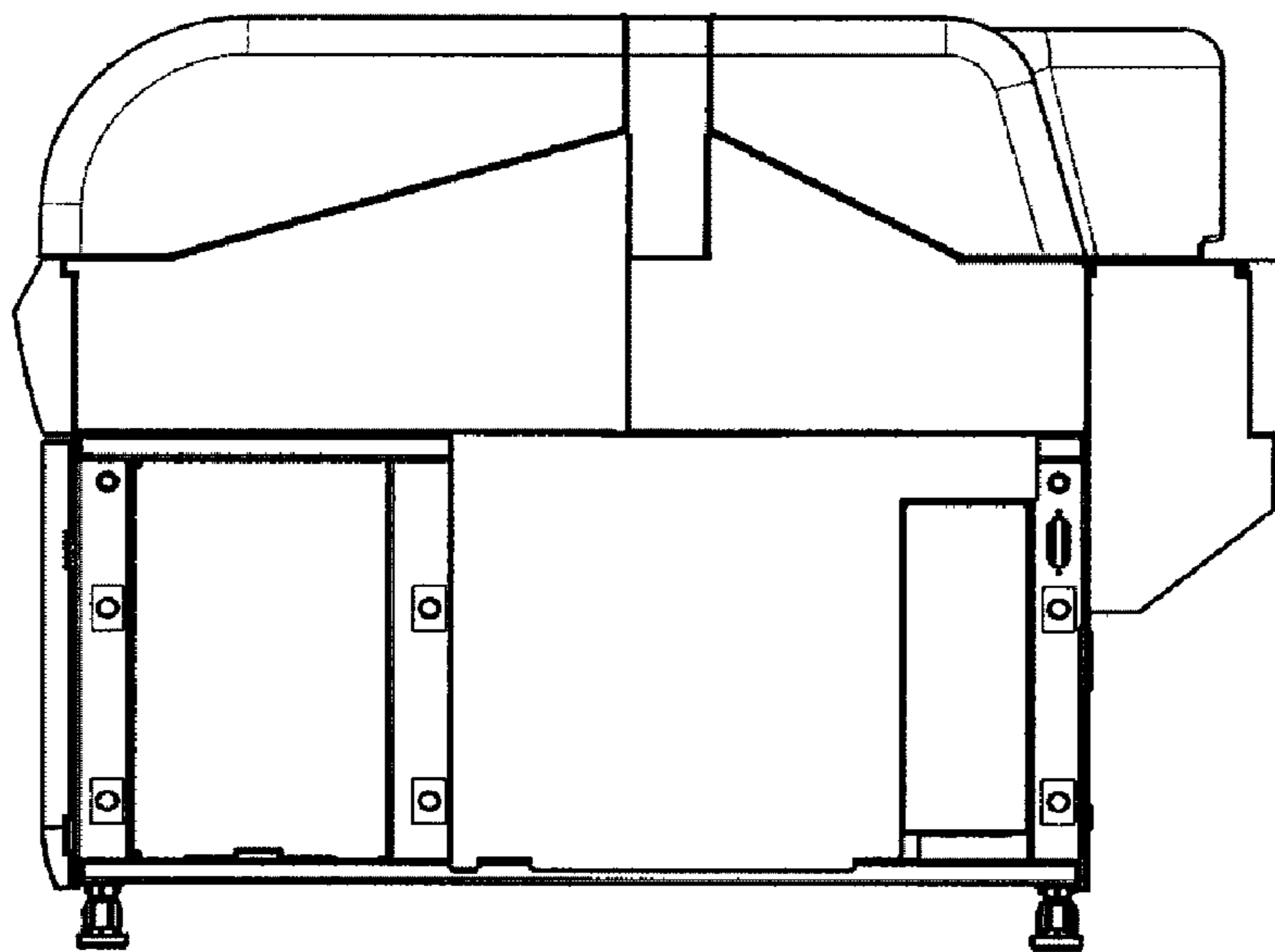

FIG. 30

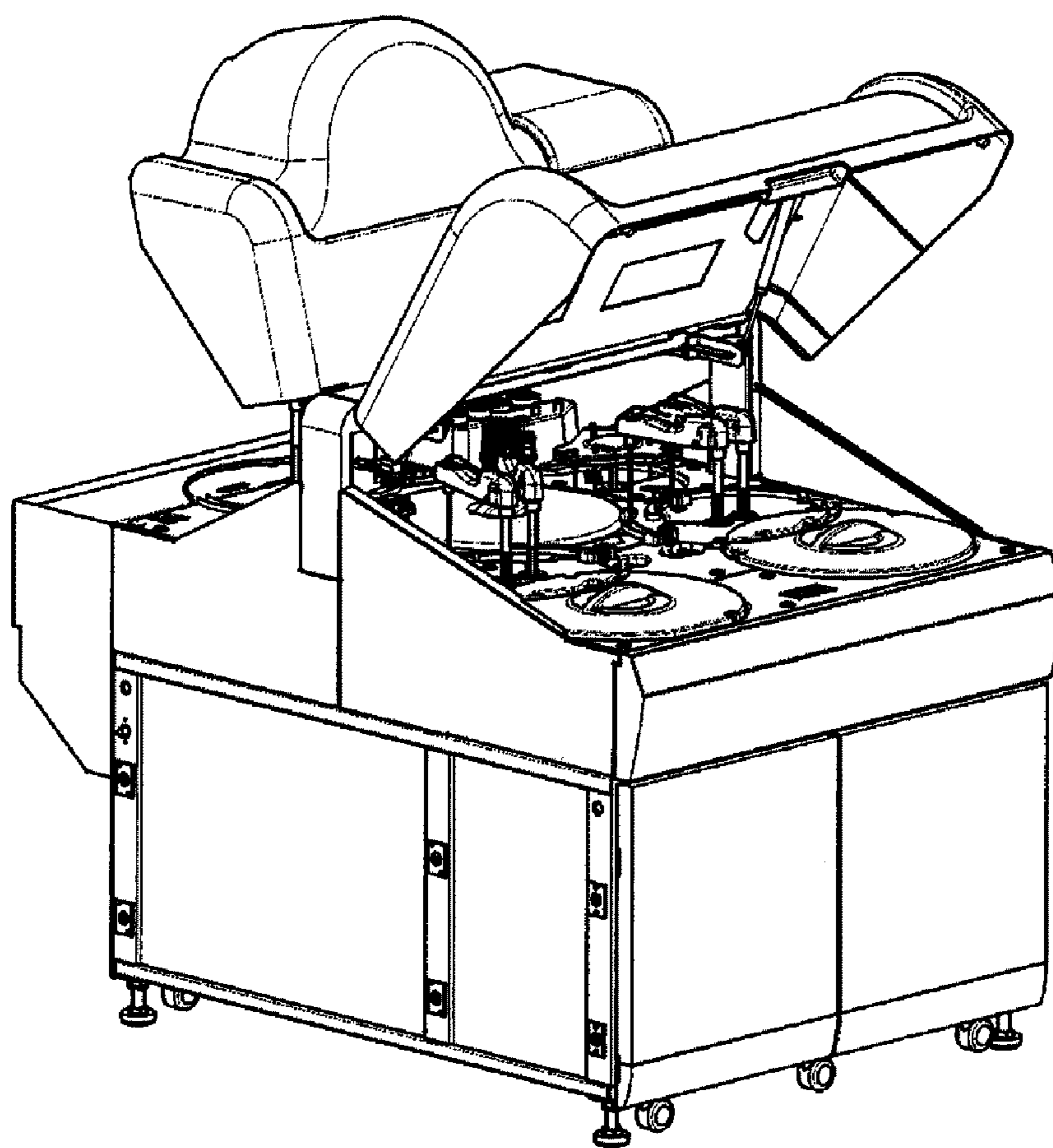

FIG. 31

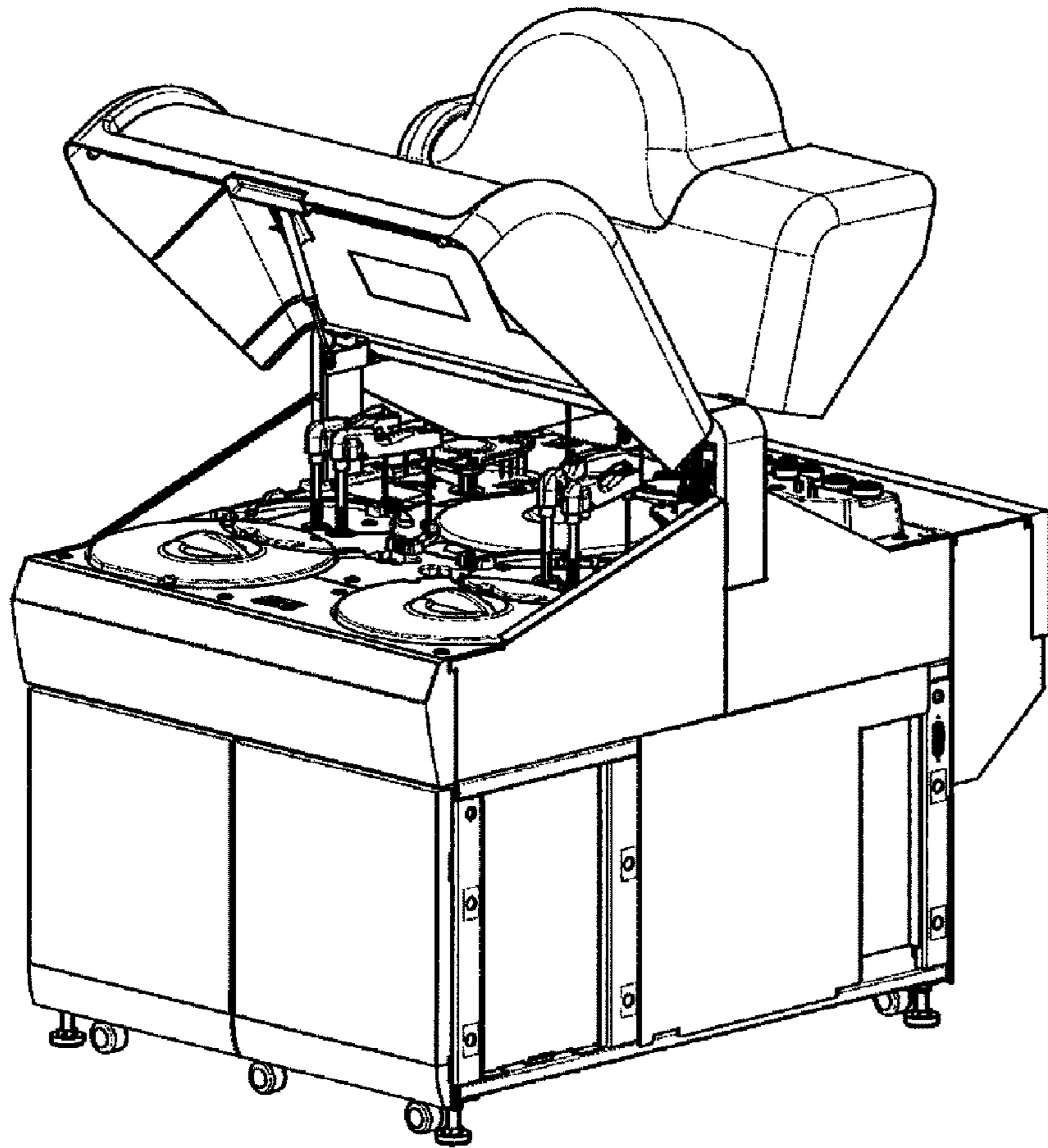

FIG. 32

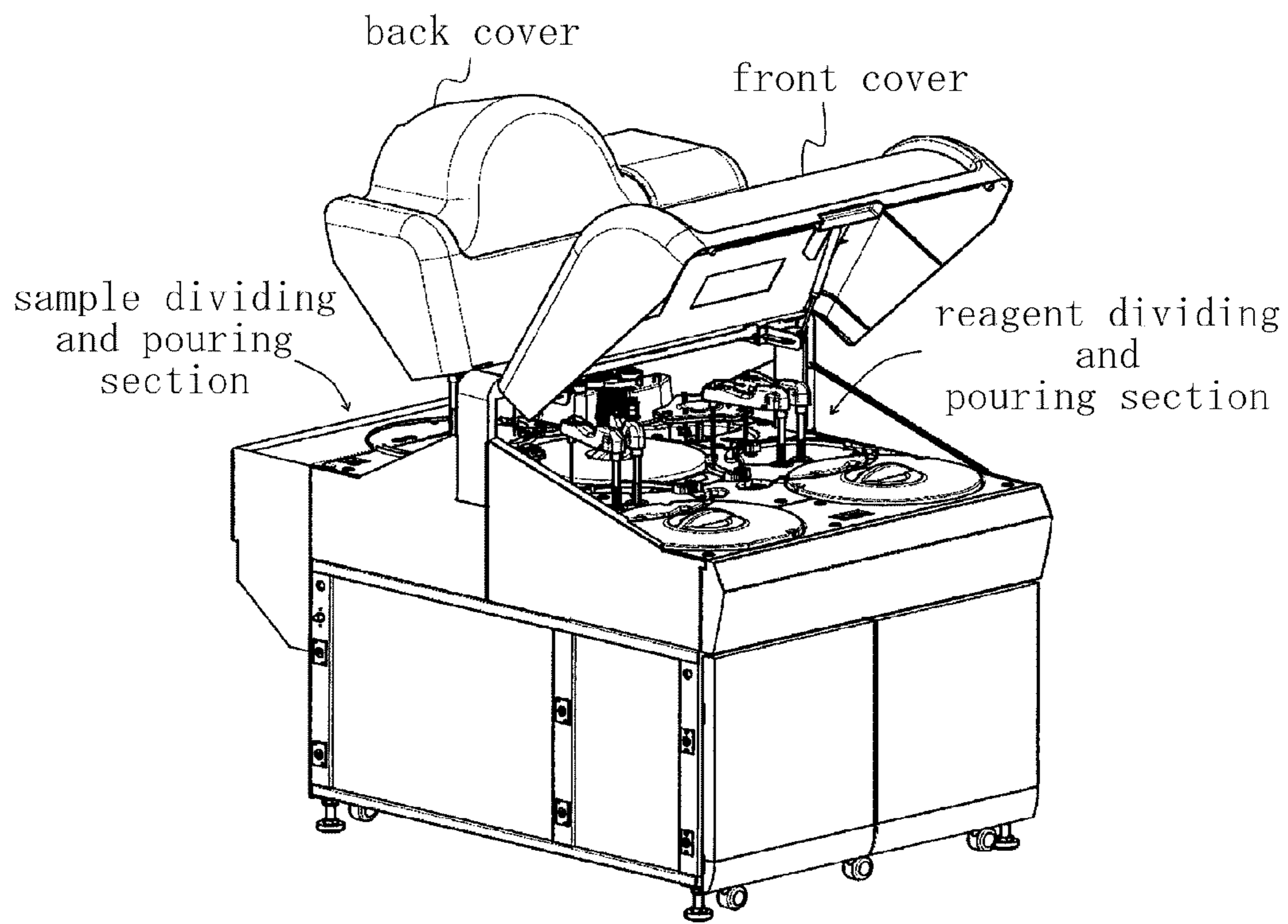

FIG. 33