



US00D645116S

(12) **United States Design Patent**
McKean et al.

(10) **Patent No.:** **US D645,116 S**

(45) **Date of Patent:** **** Sep. 13, 2011**

(54) **MOVING BED BIOFILM REACTOR MEDIA**

(75) Inventors: **Colin McKean**, Wauwatosa, WI (US);
Todd Schwingle, Mukwonago, WI (US);
Michael Casey Whittier, Waukesha, WI (US)

(73) Assignee: **Siemens Industry, Inc.**, Alpharetta, GA (US)

(**) Term: **14 Years**

(21) Appl. No.: **29/375,844**

(22) Filed: **Sep. 28, 2010**

(51) **LOC (9) Cl.** **23-01**

(52) **U.S. Cl.** **D23/207**

(58) **Field of Classification Search** D23/207,
D23/209, 269; 261/94, DIG. 72; 210/150,
210/151, 616, 617

See application file for complete search history.

(56) **References Cited**

U.S. PATENT DOCUMENTS

3,957,931	A *	5/1976	Ellis et al.	261/98
D337,148	S *	7/1993	Burns	D23/207
D353,438	S	12/1994	Yuksel	
D354,544	S *	1/1995	Erwes	D23/207
5,458,779	A	10/1995	Odegaard	
5,534,202	A	7/1996	Roberts et al.	
5,543,039	A *	8/1996	Odegaard	210/150
5,673,481	A	10/1997	Roberts et al.	
5,690,819	A	11/1997	Chianh	
5,779,886	A	7/1998	Couture	
5,833,867	A	11/1998	Hensley	
6,007,915	A *	12/1999	Rukovena	428/397
6,036,863	A	3/2000	Brockdorff	
D465,257	S	11/2002	Van Olst et al.	
6,524,849	B1	2/2003	Swift et al.	
6,889,963	B2	5/2005	Niknafs et al.	
7,468,134	B2	12/2008	Hoang	
D611,120	S	3/2010	Brockdorff	
D611,568	S *	3/2010	Westrum	D23/207
D612,007	S	3/2010	Brockdorff	
D618,760	S *	6/2010	Flournoy et al.	D23/207
7,775,507	B2 *	8/2010	Niknafs et al.	261/94
7,862,013	B2 *	1/2011	Miller et al.	261/94

OTHER PUBLICATIONS

<http://www.wateronline.com/product.mvc/AnoxKaldnes-MBBR-0001?VNETCOOKIE=NO>; AnoxKaldnes MBBR; N.A. Water , undated.

HIT™ Process, Headworks® Integrated Treatment Process™, Headworks BIO™; 2009.

Infilco; Headworks brochure; 2009.

Infilco, METEOR® Brochure; 2009.

Aqwise; Integrated Water & Wastewater Treatment Solutions; "Extending Nature's Capacity," www.aqwise.com; 2010.

http://www.createchaqua.com/bio_elements.php; Bio-Elements, undated.

<http://www.entexinc.com/solutions/bioportz>; BioPortz Moving Media System, 2010.

GEA 2H Water Technologies Ltd.; Product Profile, Random Media 2H-BCN / 2H-BCP; Sep. 2009.

* cited by examiner

Primary Examiner — Robin V Webster

(57) **CLAIM**

The ornamental design for a moving bed biofilm reactor media, as shown and described.

DESCRIPTION

FIG. 1 is a perspective view of a first embodiment of a moving bed biofilm reactor media design;

FIG. 2 is a side view thereof, with the opposite side being a minor image thereof; and

FIG. 3 is a top plan view thereof, with the bottom plan view being a mirror image thereof;

FIG. 4 is a perspective view of a second embodiment of a moving bed biofilm reactor media design;

FIG. 5 is a side view thereof, with the opposite side being a minor image thereof; and,

FIG. 6 is a top plan view thereof, with the bottom plan view being a mirror image thereof.

All broken lines shown in the drawings are for illustrative purposes only and form no part of the claimed design.

1 Claim, 4 Drawing Sheets

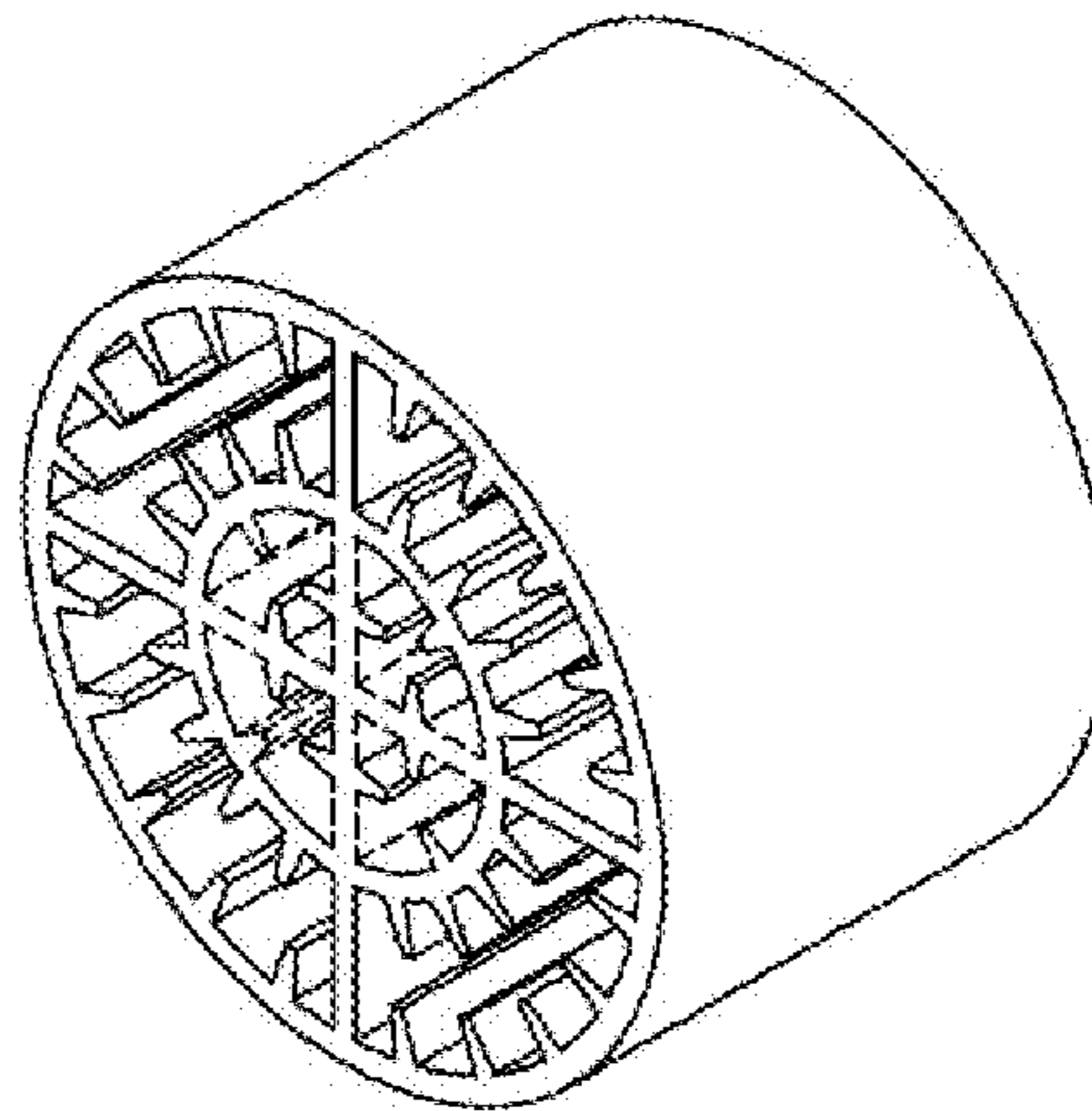
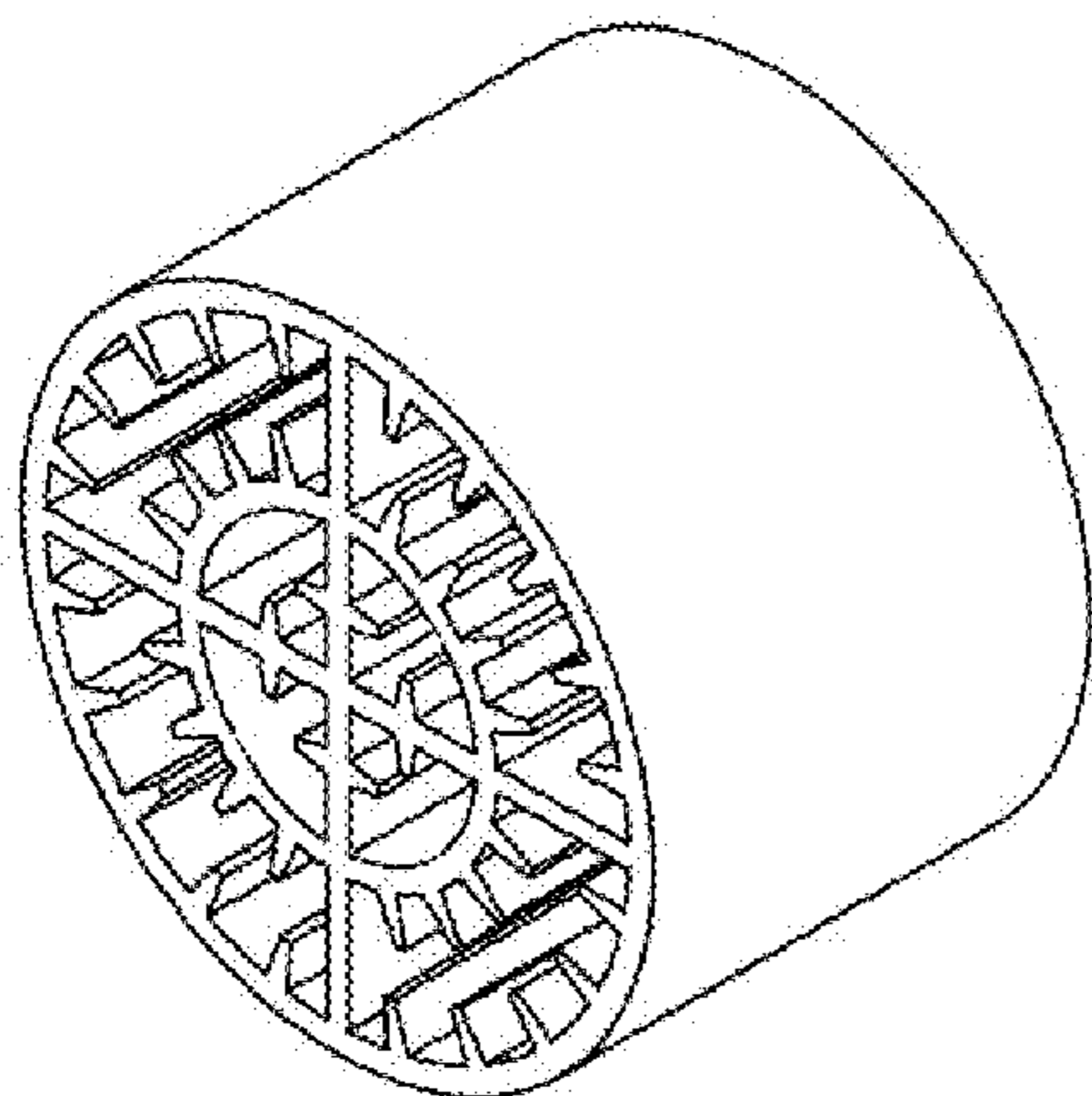

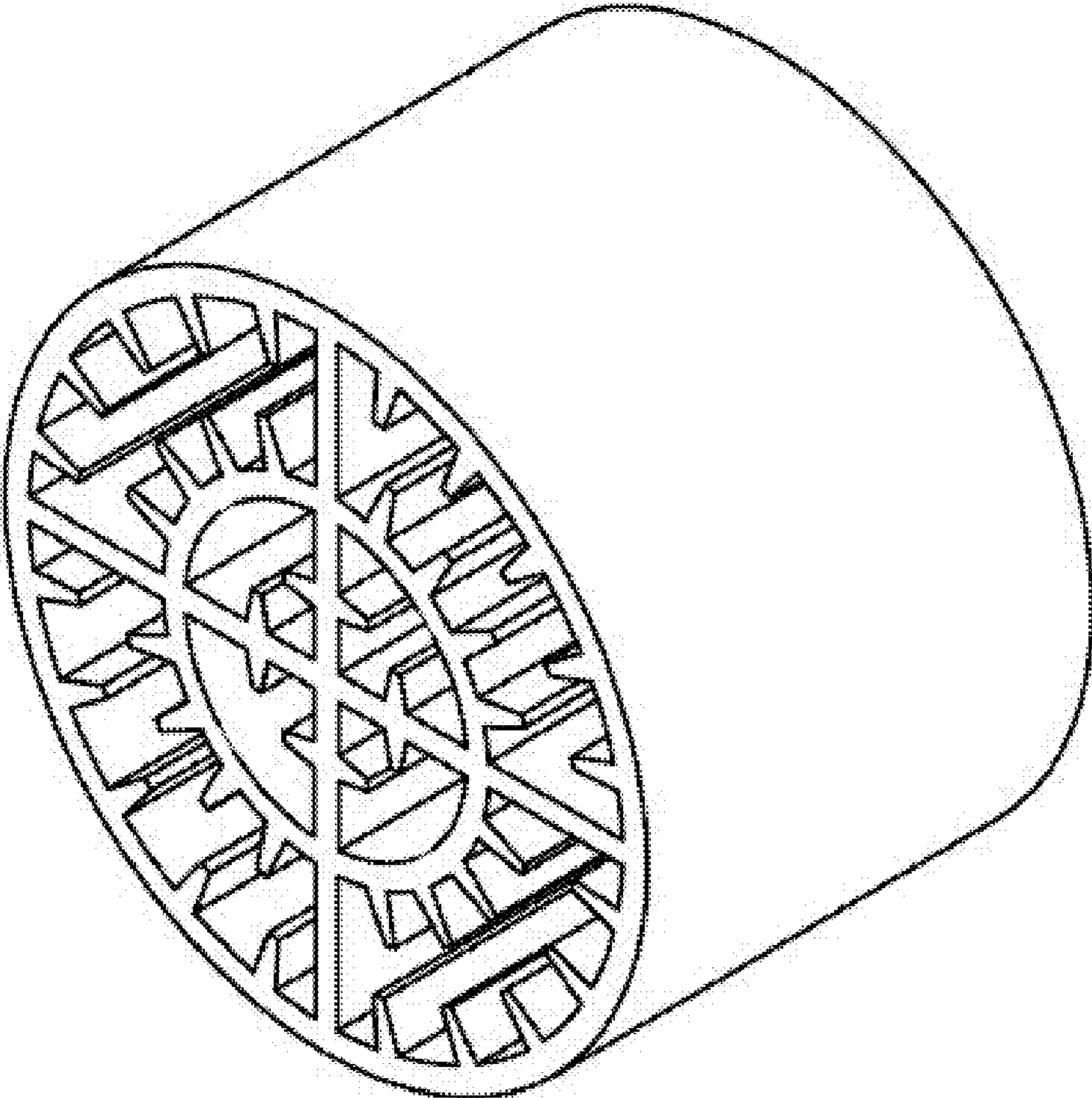

FIG. 1

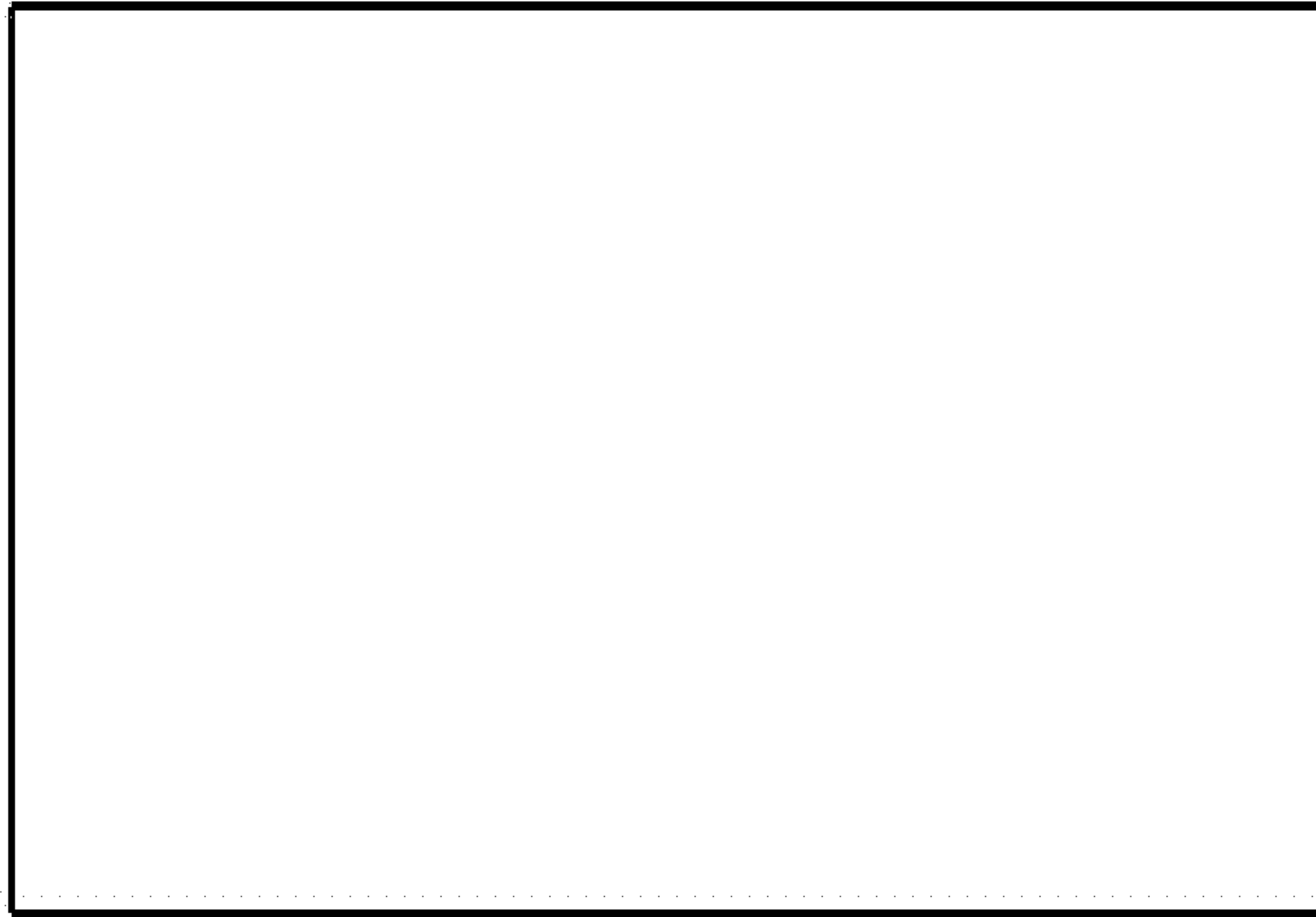

FIG. 2

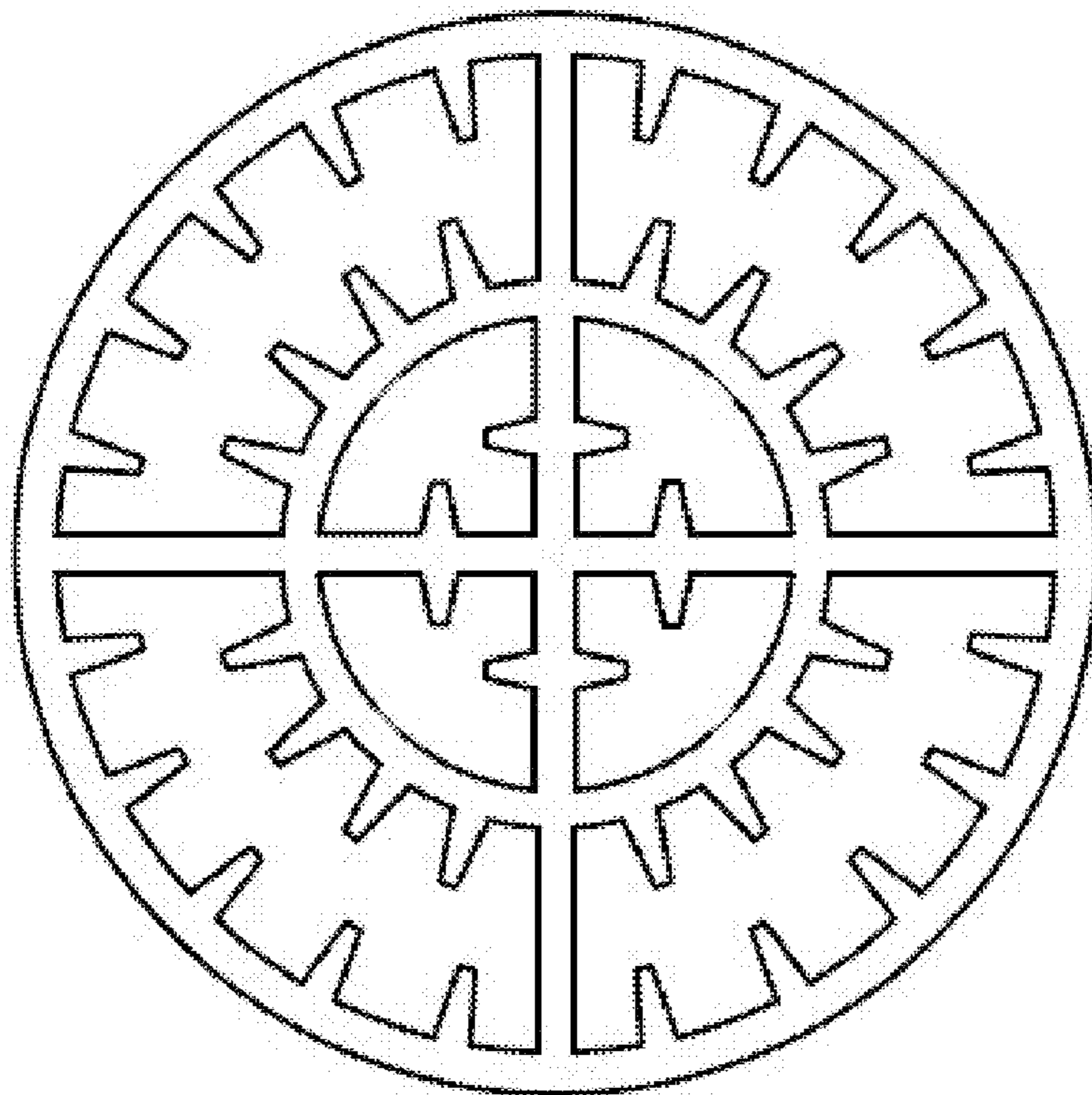

FIG. 3

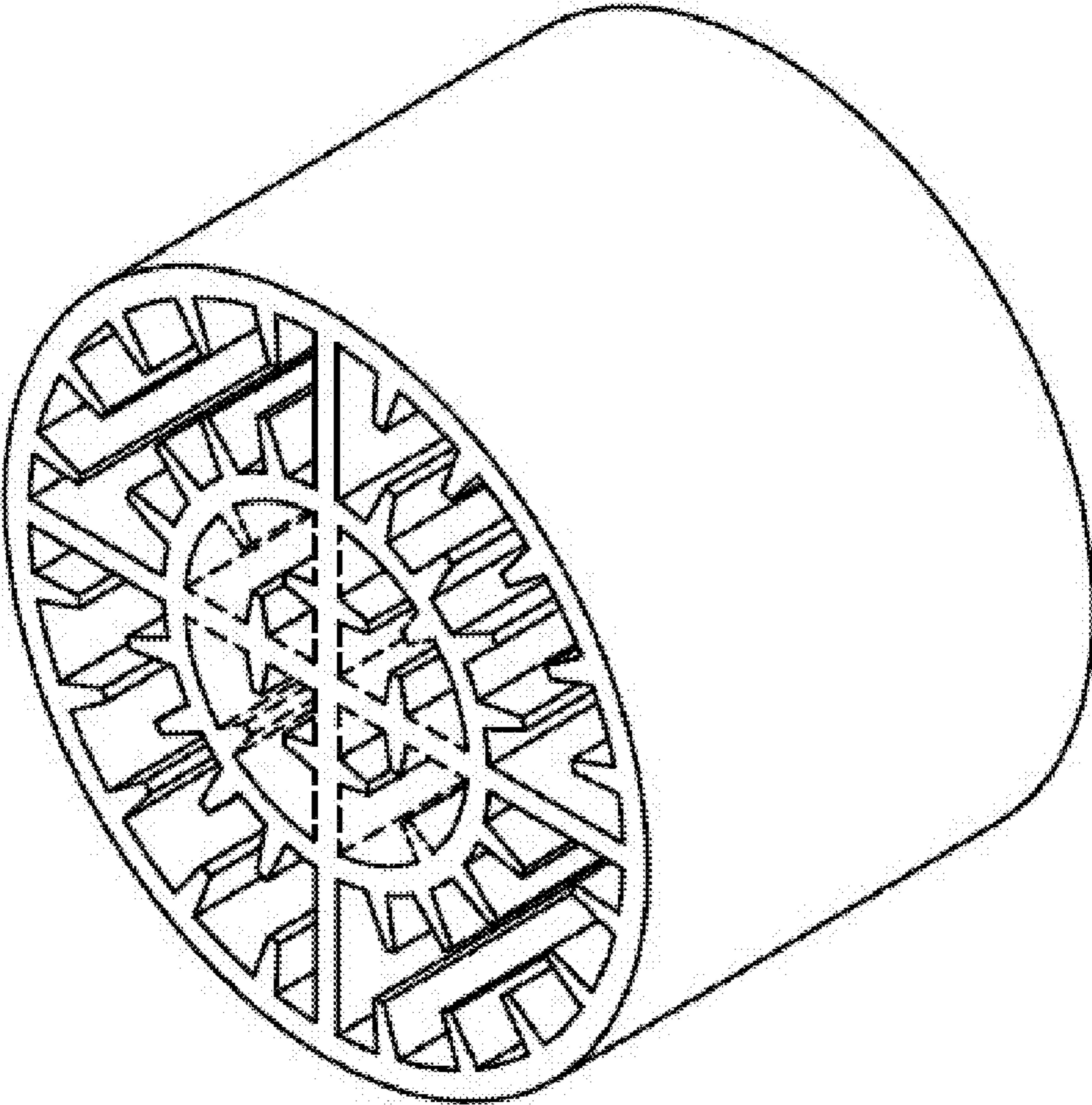

FIG. 4

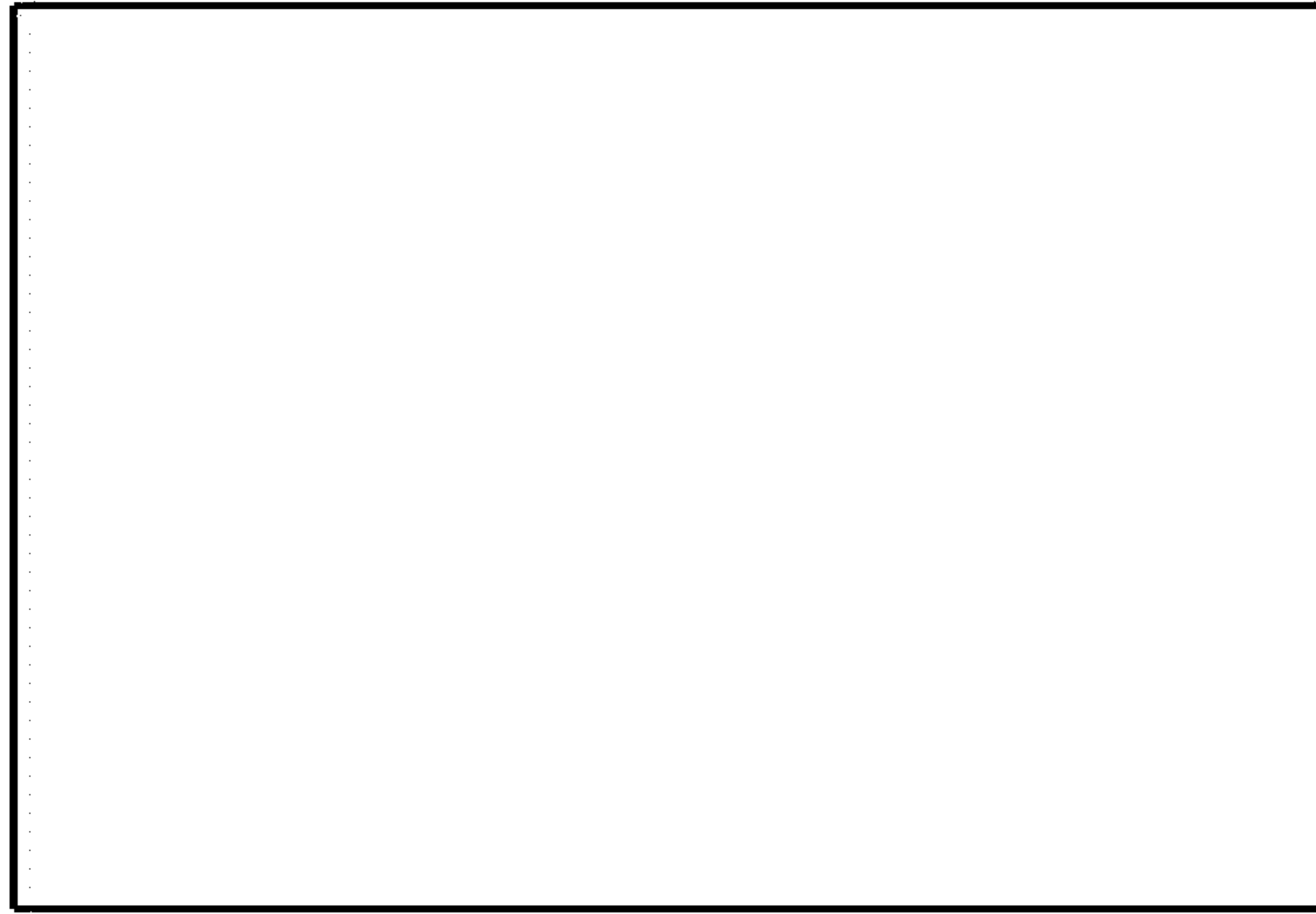

FIG. 5

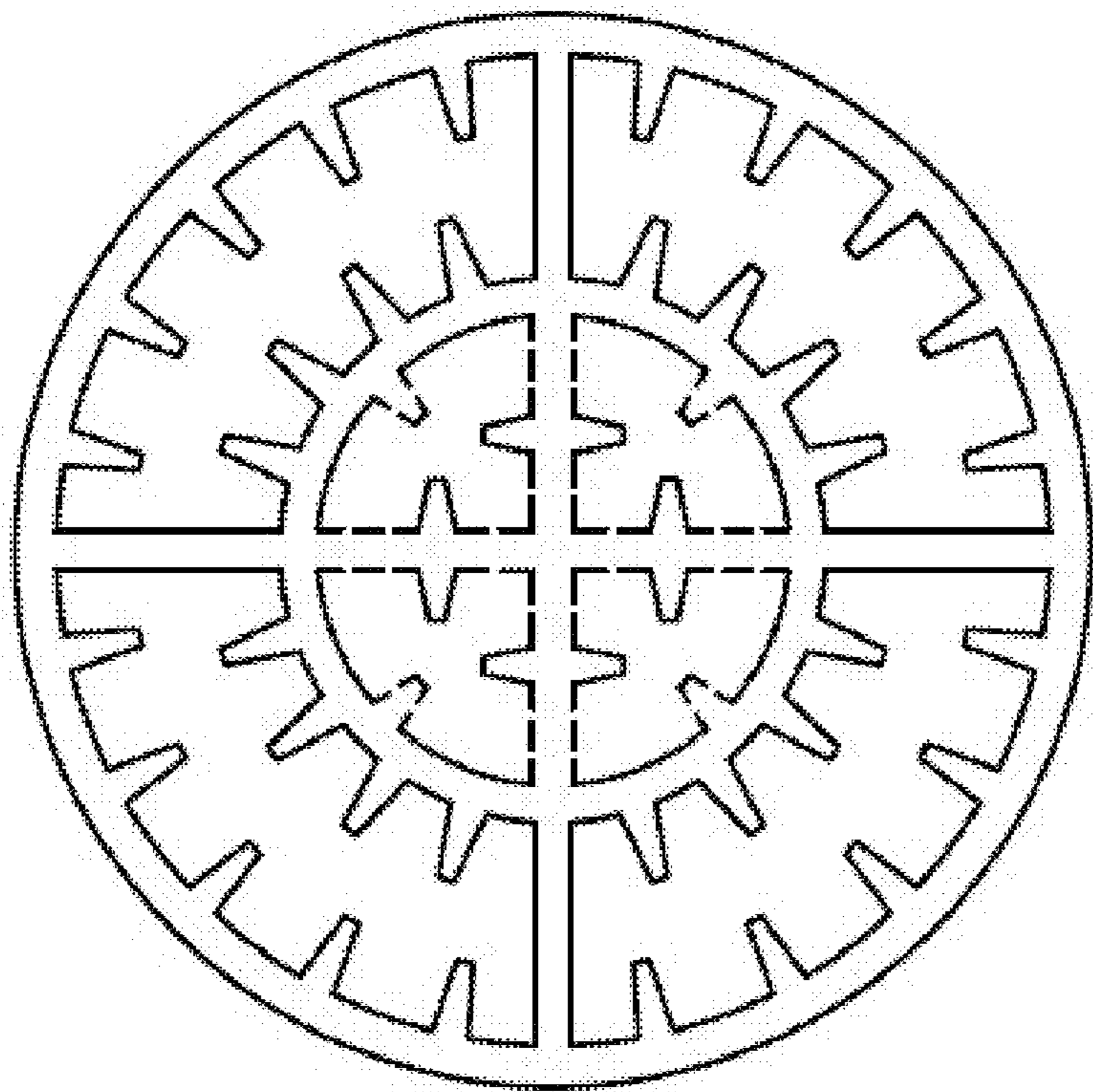

FIG. 6