



US00D645053S

(12) **United States Design Patent**
Shea et al.

(10) **Patent No.:** **US D645,053 S**

(45) **Date of Patent:** **** Sep. 13, 2011**

(54) **VALVE CAP FOR A FUEL CELL**

(75) Inventors: **Maureen L. Shea**, Wilmette, IL (US);
Eric S. Gibson, Round Lake, IL (US);
Robert S. Buetow, Lake in the Hills, IL (US)

(73) Assignee: **Illinois Tool Works Inc.**, Glenview, IL (US)

(**) Term: **14 Years**

(21) Appl. No.: **29/334,345**

(22) Filed: **Mar. 25, 2009**

Related U.S. Application Data

(62) Division of application No. 29/306,898, filed on Apr. 18, 2008, now Pat. No. Des. 590,840.

(51) **LOC (9) Cl.** **15-01**

(52) **U.S. Cl.** **D15/5**

(58) **Field of Classification Search** D15/1-5;
55/337; 123/41.67, 198 E; 418/91; 60/299,
60/274, 324; 23/288 F; 222/1, 94; 227/10

See application file for complete search history.

(56) **References Cited**

U.S. PATENT DOCUMENTS

D299,950 S	2/1989	Canaan et al.
5,115,944 A	5/1992	Nikolich
6,302,297 B1	10/2001	Richardson et al.
6,796,478 B2	9/2004	Shkolnikov et al.
D590,840 S *	4/2009	Shea et al. D15/5

* cited by examiner

Primary Examiner — Lisa Lichtenstein

(74) *Attorney, Agent, or Firm* — Greer, Burns & Crain, Ltd.

(57) **CLAIM**

The ornamental design for a valve cap for a fuel cell, as shown and described.

DESCRIPTION

FIG. 1 is a top perspective view of an embodiment of the present valve cap design;

FIG. 2 is a front view of same, the rear view being identical;

FIG. 3 is a side view of same, both sides being identical; and,

FIG. 4 is a top view of same.

The broken line showing of a portion of a valve cap for a fuel cell is included for the purpose of illustrating environmental structure and forms no part of the claimed design.

1 Claim, 2 Drawing Sheets

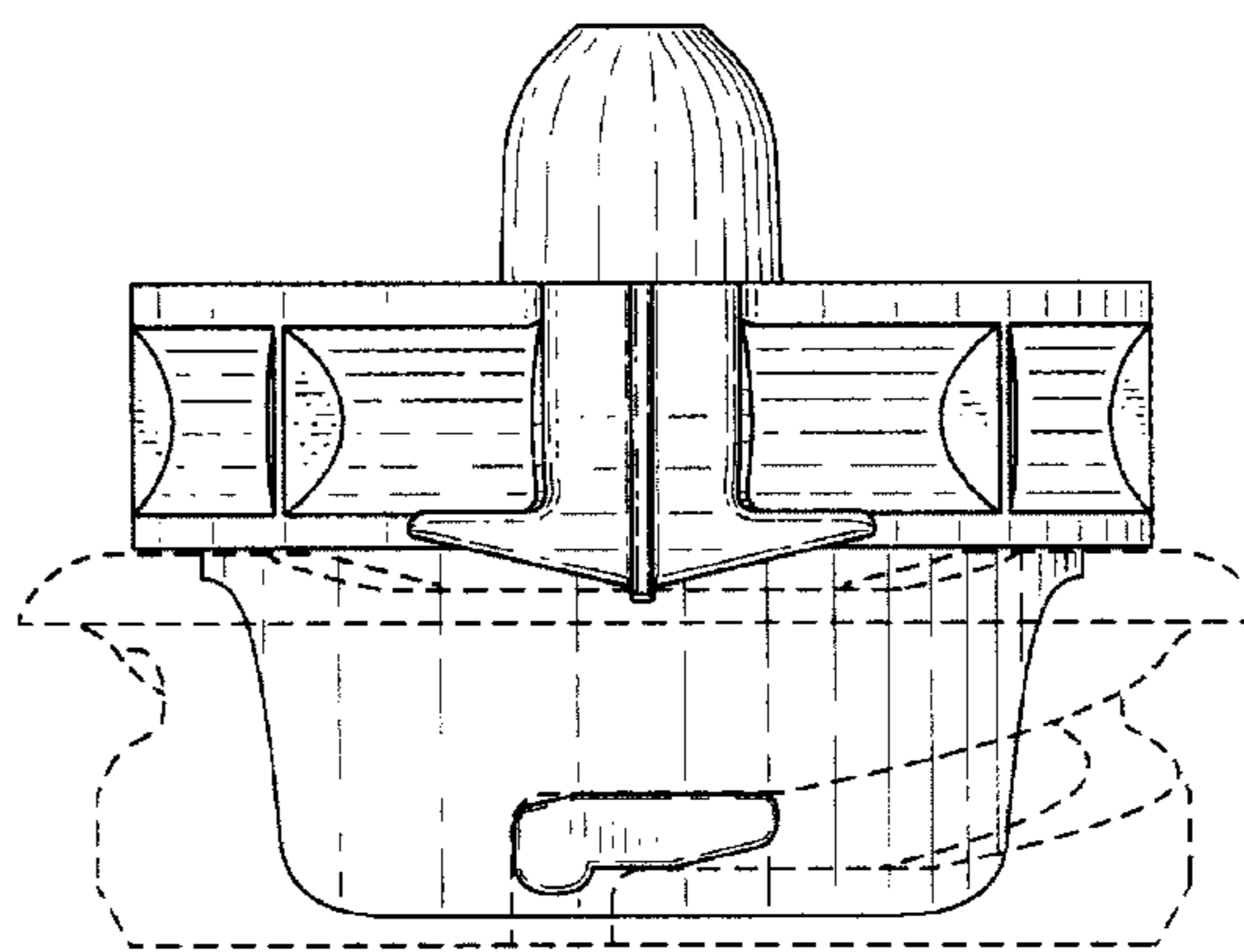
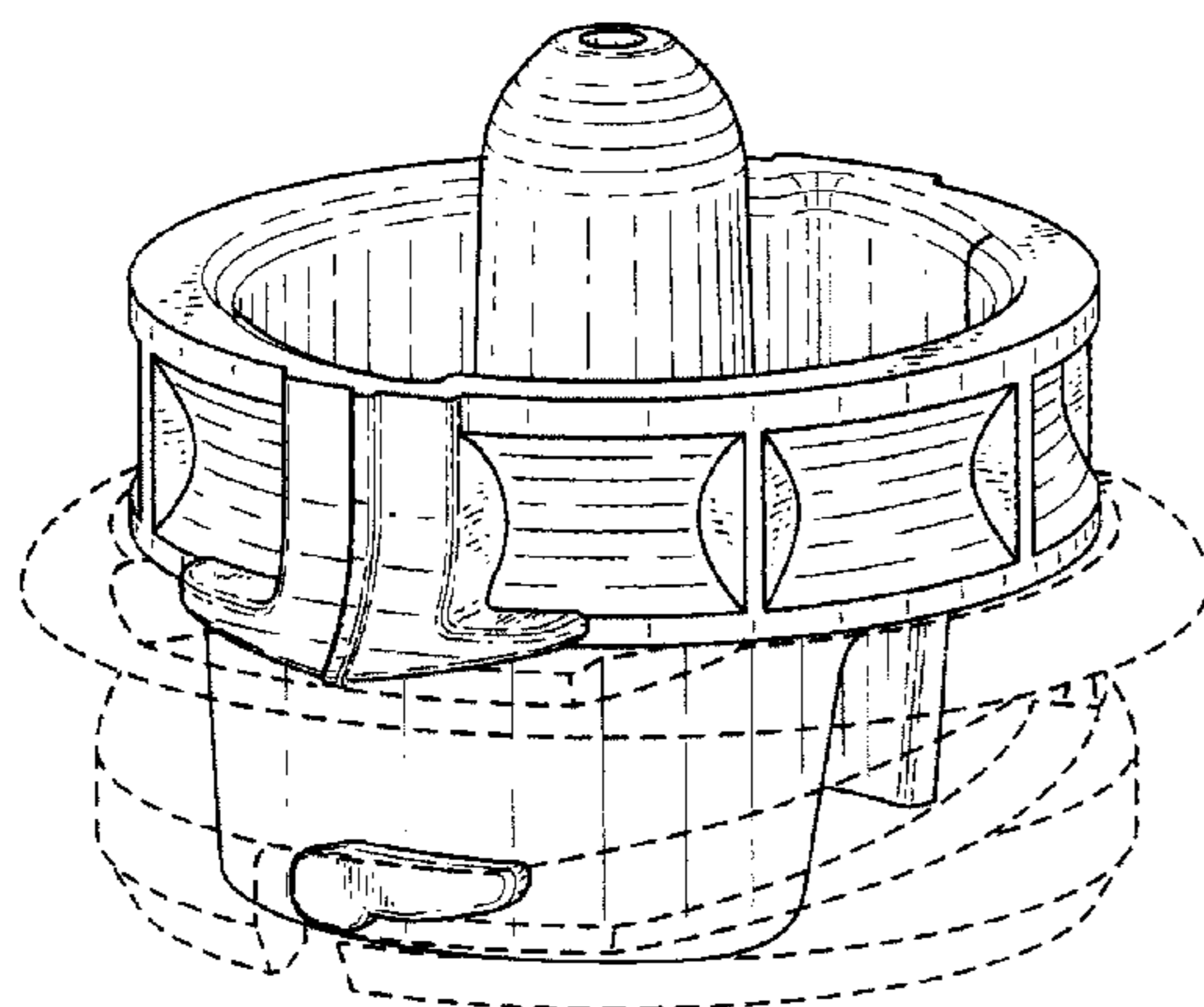

FIG.1

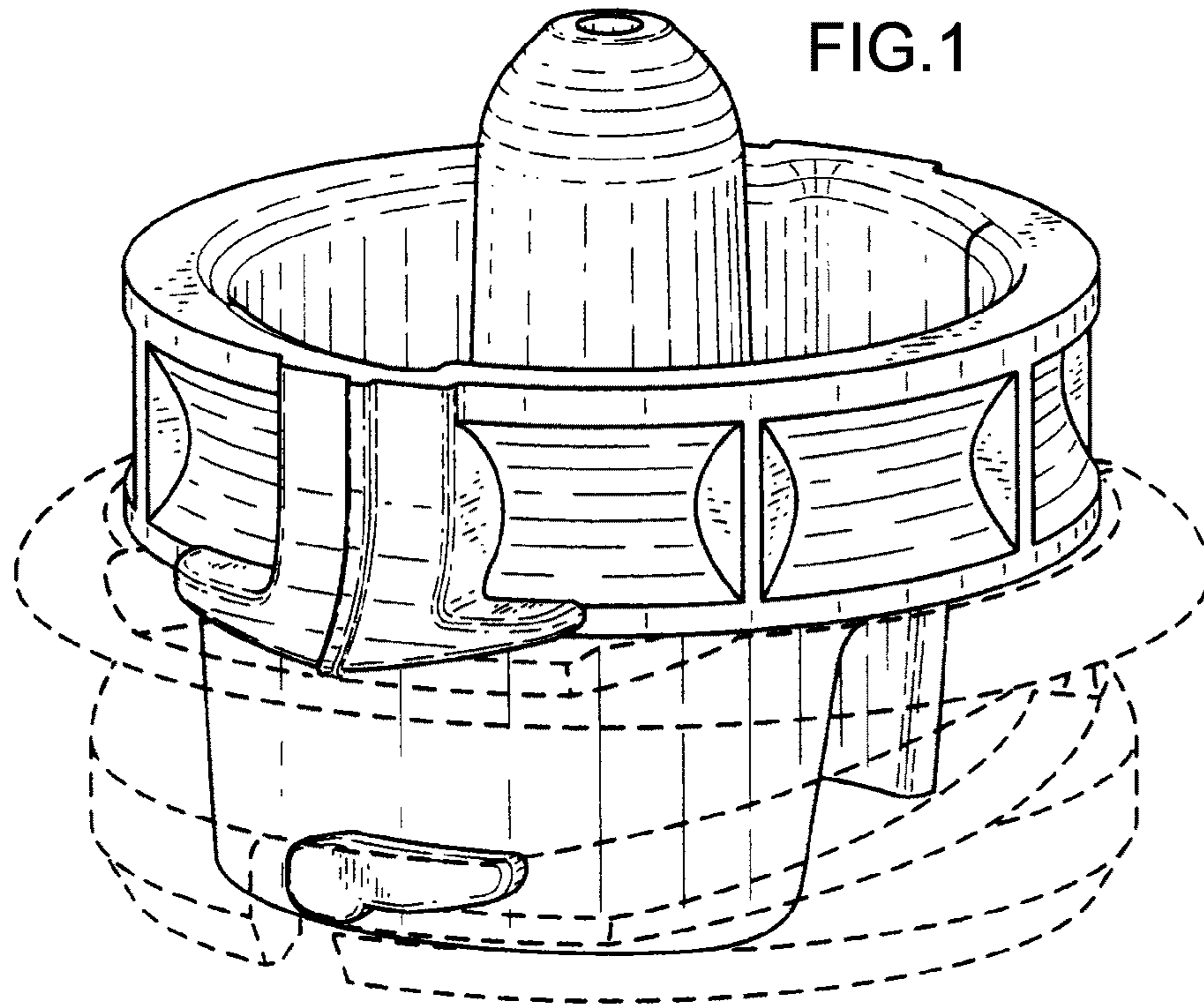

FIG.2

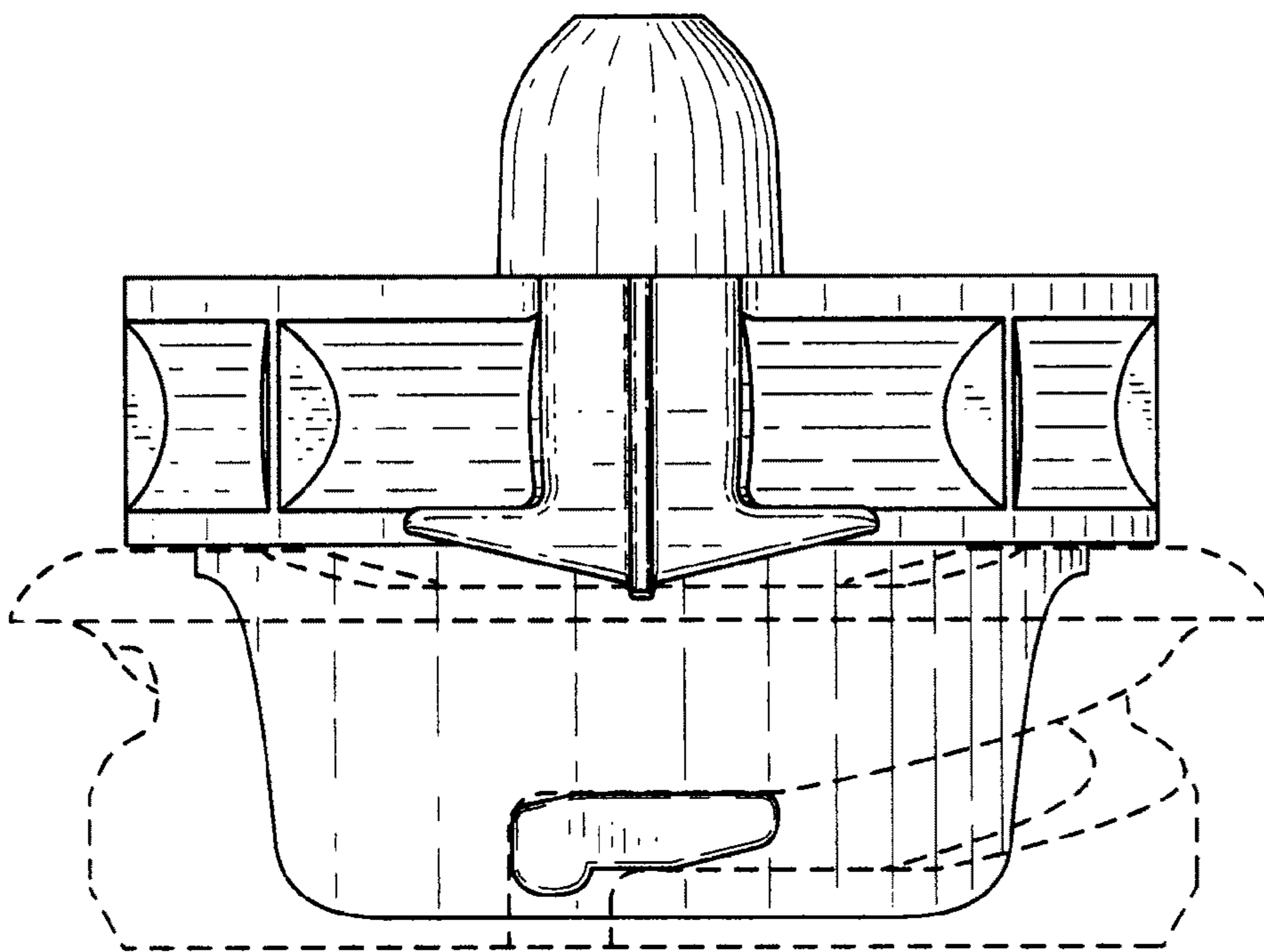

FIG.3

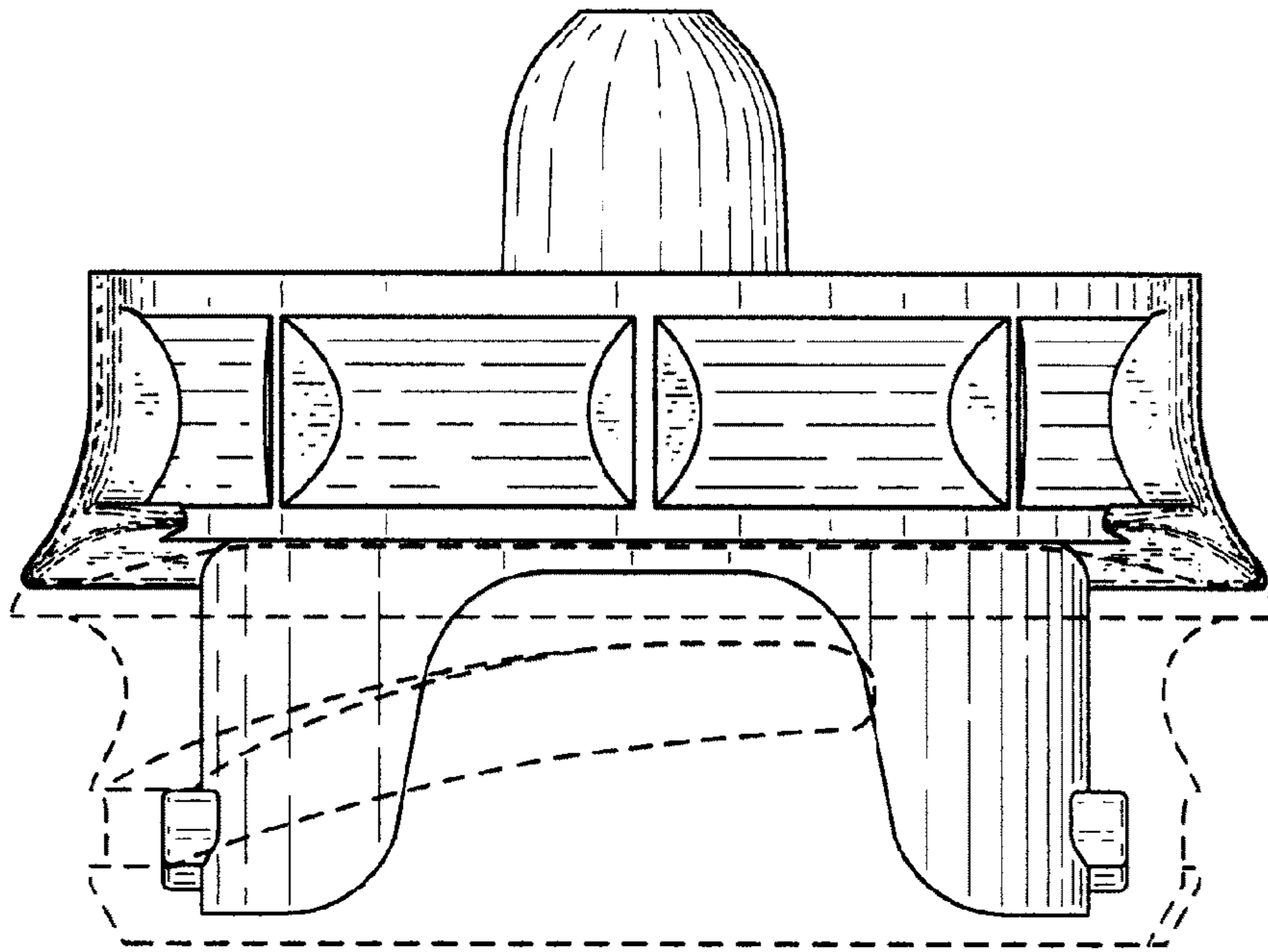

FIG.4

