



US00D645020S

(12) **United States Design Patent**
Chen et al.

(10) **Patent No.:** **US D645,020 S**

(45) **Date of Patent:** **** Sep. 13, 2011**

(54) **BIDIRECTIONAL BONE CONDUCTION
TACTICAL COMMUNICATION SYSTEM**

(75) Inventors: **Qigang Chen**, Shenzhen (CN);
Zengfeng Li, Shenzhen (CN)

(73) Assignee: **Shenzhen Qili Technology
Development Co., Ltd.**, Shenzhen (CN)

(**) Term: **14 Years**

(21) Appl. No.: **29/364,458**

(22) Filed: **Jun. 24, 2010**

(51) **LOC (9) Cl.** **14-01**

(52) **U.S. Cl.** **D14/205**

(58) **Field of Classification Search** D14/205,
D14/206, 225, 226, 192, 218, 137, 185; D29/112;
2/209, 423; 181/129, 130; 379/430, 431,
379/433.03, 433.02; 381/91, 361, 380, 381;
455/90.3; D13/168

See application file for complete search history.

(56) **References Cited**

U.S. PATENT DOCUMENTS

4,325,142	A	*	4/1982	Nakazawa	455/90.3
D280,096	S	*	8/1985	Meister	D14/226
D282,661	S	*	2/1986	Imazeki	D14/194
D286,632	S	*	11/1986	Teunis	D14/205
4,754,484	A	*	6/1988	Larkin et al.	379/430
D355,915	S	*	2/1995	Chan	D14/225
D388,094	S	*	12/1997	Tokiyama et al.	D14/226
D415,767	S	*	10/1999	Page et al.	D14/226
5,974,304	A	*	10/1999	Chen	455/90.2
D453,506	S	*	2/2002	Liou et al.	D14/225
D477,816	S	*	7/2003	Yahaya et al.	D14/137
D493,175	S	*	7/2004	Schmidt et al.	D14/433
D497,357	S	*	10/2004	Allum et al.	D14/206
D549,694	S	*	8/2007	Viduya et al.	D14/223
D556,155	S	*	11/2007	Andre et al.	D13/168
D565,023	S	*	3/2008	Yamagishi	D14/205
D576,157	S	*	9/2008	Nishizawa	D14/225
D583,806	S	*	12/2008	Okazaki et al.	D14/225
D595,262	S	*	6/2009	Nousiainen	D14/206
D602,002	S	*	10/2009	Asai	D14/206
D605,168	S	*	12/2009	Jaakkola et al.	D14/205
D607,855	S	*	1/2010	Nakagawa	D14/137

D613,266	S	*	4/2010	Barry et al.	D14/205
D617,771	S	*	6/2010	Groves et al.	D14/206
D622,697	S	*	8/2010	Kolton	D14/205

* cited by examiner

Primary Examiner — Paula Greene

(74) *Attorney, Agent, or Firm* — WPAT, P.C.; Anthony King

(57) **CLAIM**

The ornamental design for a bidirectional bone conduction tactical communication system, as shown and described.

DESCRIPTION

FIG. 1 is a perspective view of a bidirectional bone conduction tactical communication system showing our new design; FIG. 2 is a front view of set 1 thereof; FIG. 3 is a back view of set 1 thereof; FIG. 4 is a top view of set 1 thereof; FIG. 5 is a bottom view of set 1 thereof; FIG. 6 is a left side view of set 1 thereof; FIG. 7 is a right side view of set 1 thereof; FIG. 8 is a perspective view of an intercom remote control module (set 2) of a bidirectional bone conduction tactical communication system shown separately for purposes of illustration; FIG. 9 is a front view of set 2 thereof; FIG. 10 is a back view of set 2 thereof; FIG. 11 is a top view of set 2 thereof; FIG. 12 is a bottom view of set 2 thereof; FIG. 13 is a left view of set 2 thereof; FIG. 14 is a right view of set 2 thereof; FIG. 15 is a perspective view of an intercom control (set 3) of a bidirectional bone conduction tactical communication system shown separately for purposes of illustration; FIG. 16 is a front view of set 3 thereof; FIG. 17 is a back view of set 3 thereof; FIG. 18 is a top view of set 3 thereof; FIG. 19 is a bottom view of set 3 thereof; FIG. 20 is a left view of set 3 thereof; and, FIG. 21 is a right view of set 3 thereof.

The claimed bidirectional bone conduction tactical communication system as set forth in the following specification, comprising 3 sets: a bone conduction headset (set 1), an intercom remote control module (set 2), and an intercom control part (set 3).

1 Claim, 21 Drawing Sheets

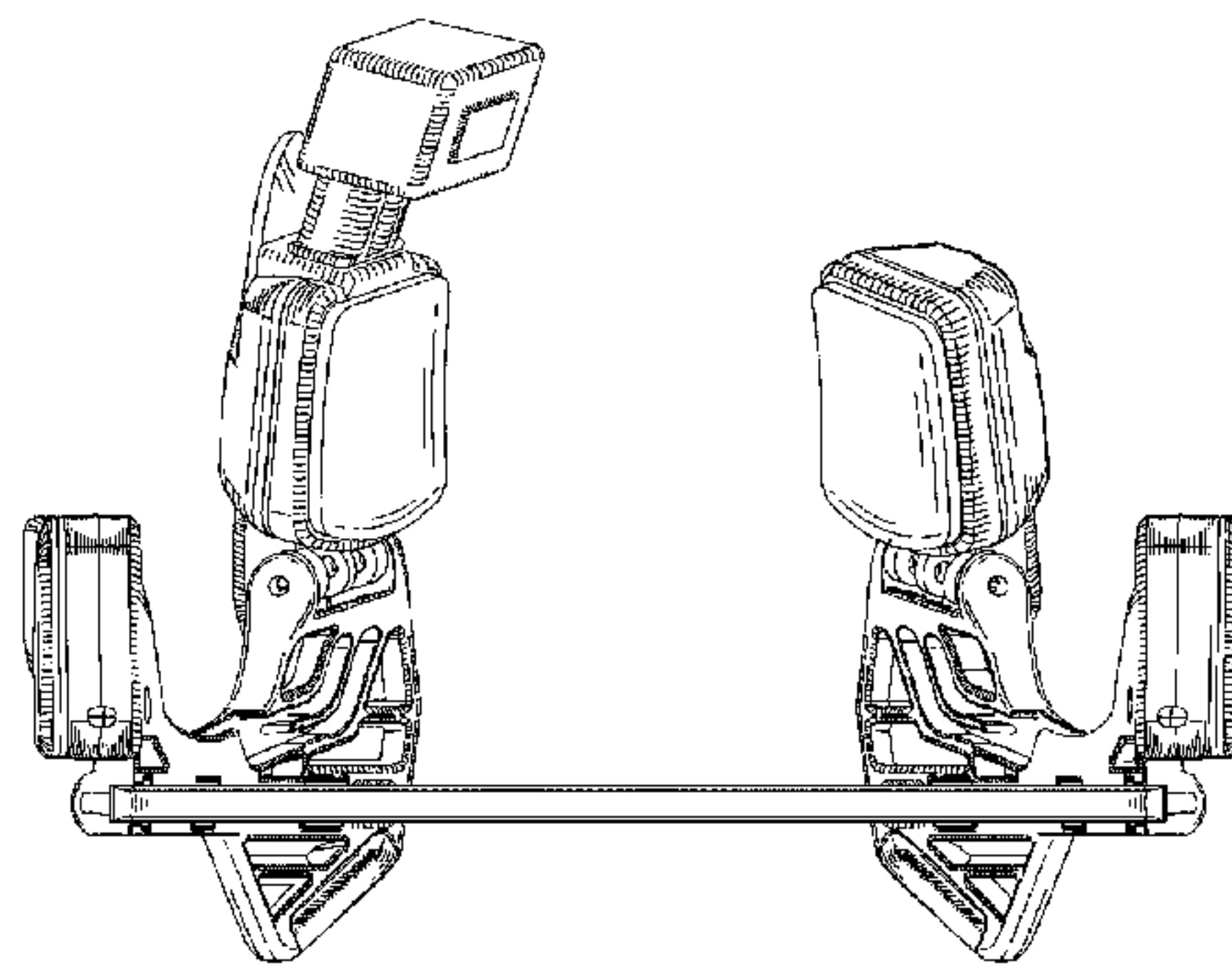
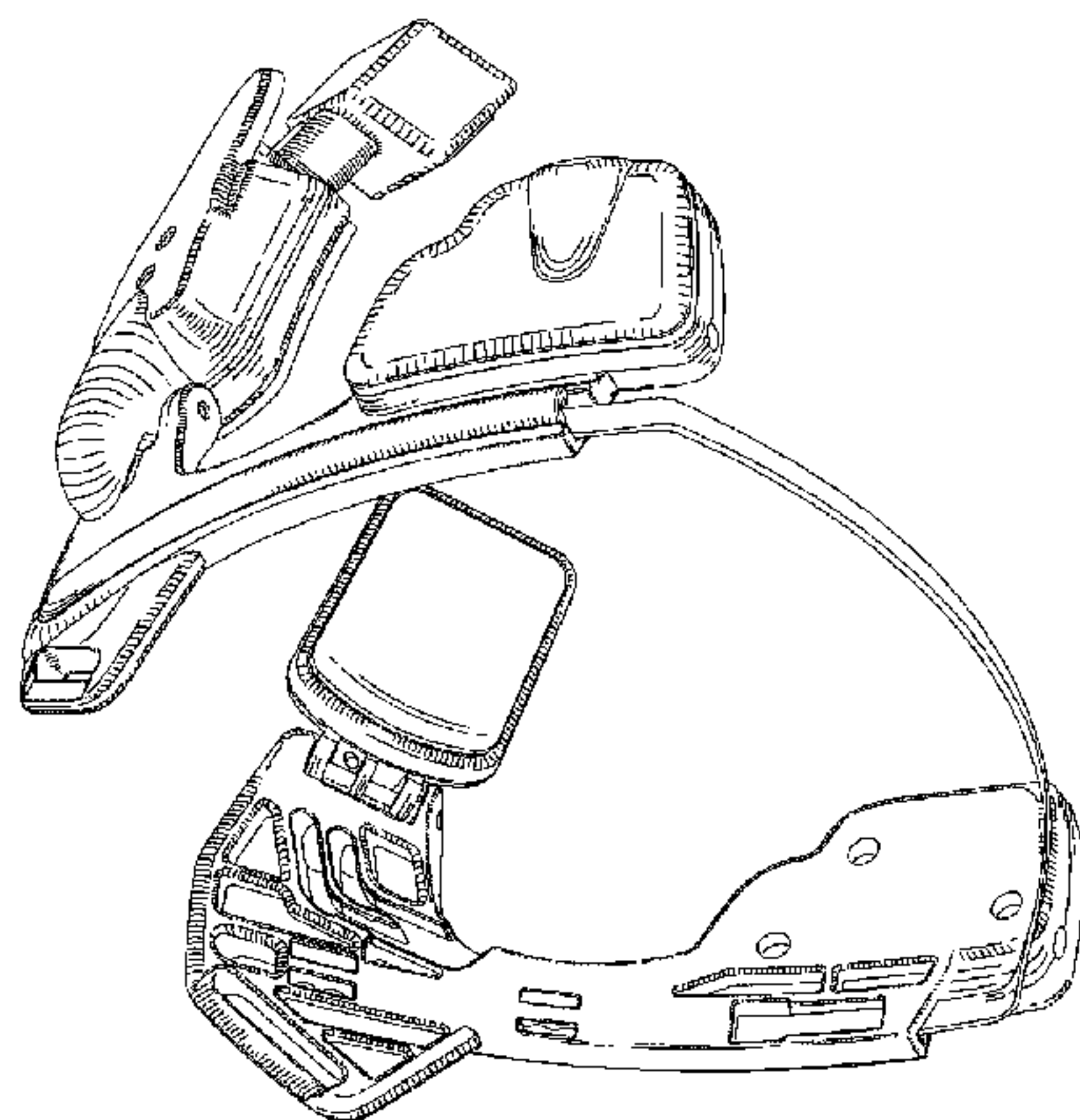

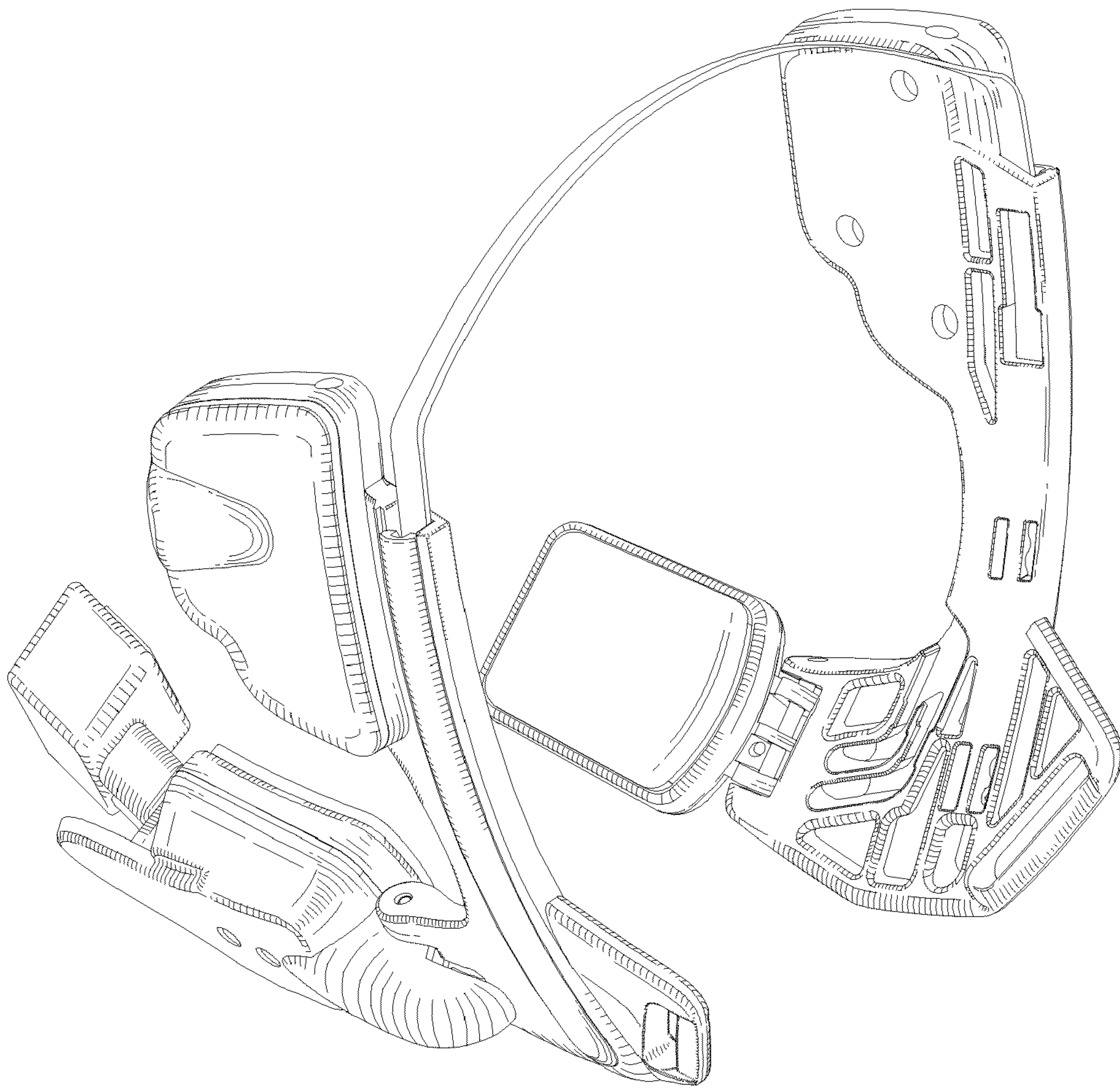

Figure 1

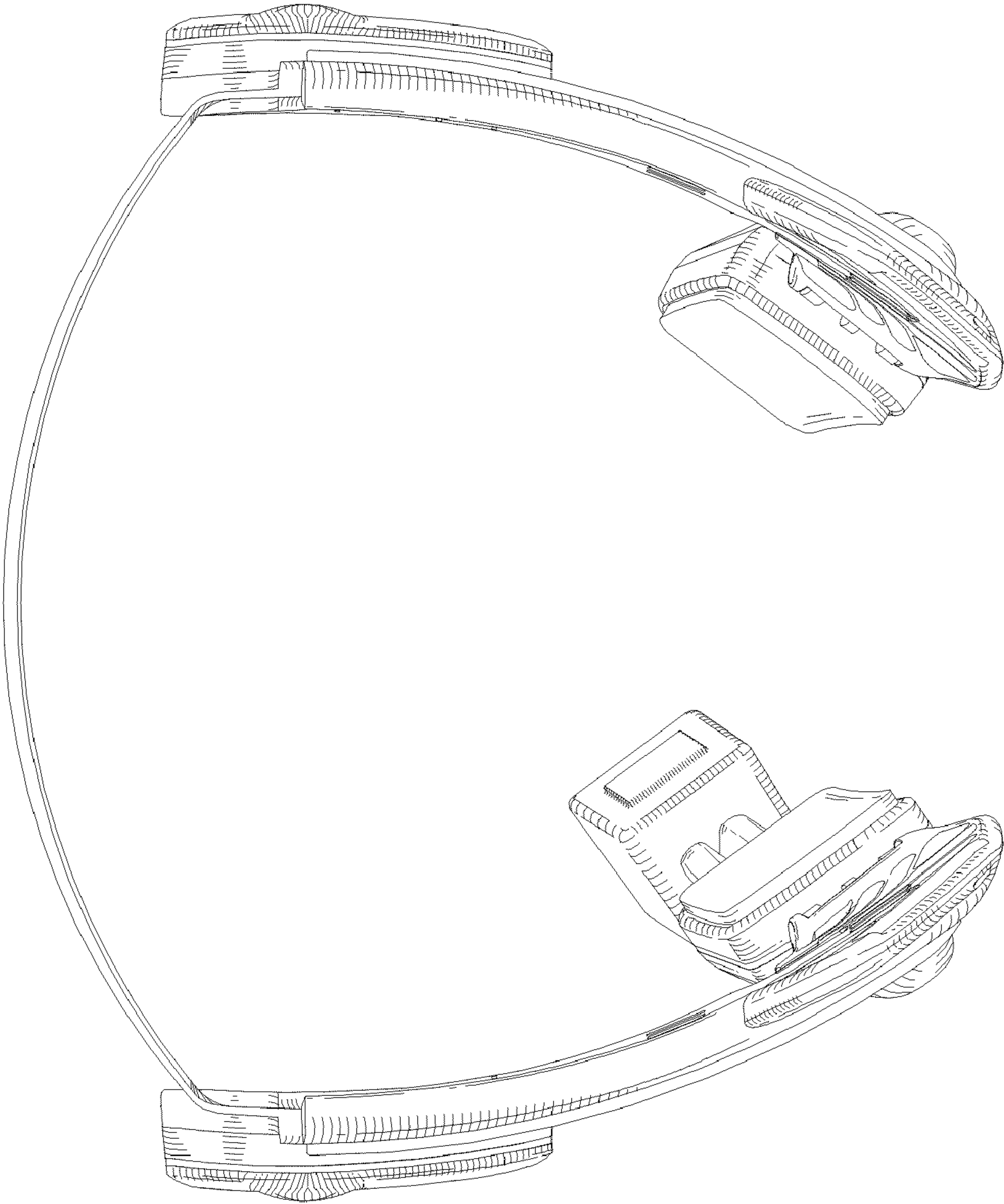

Figure 2

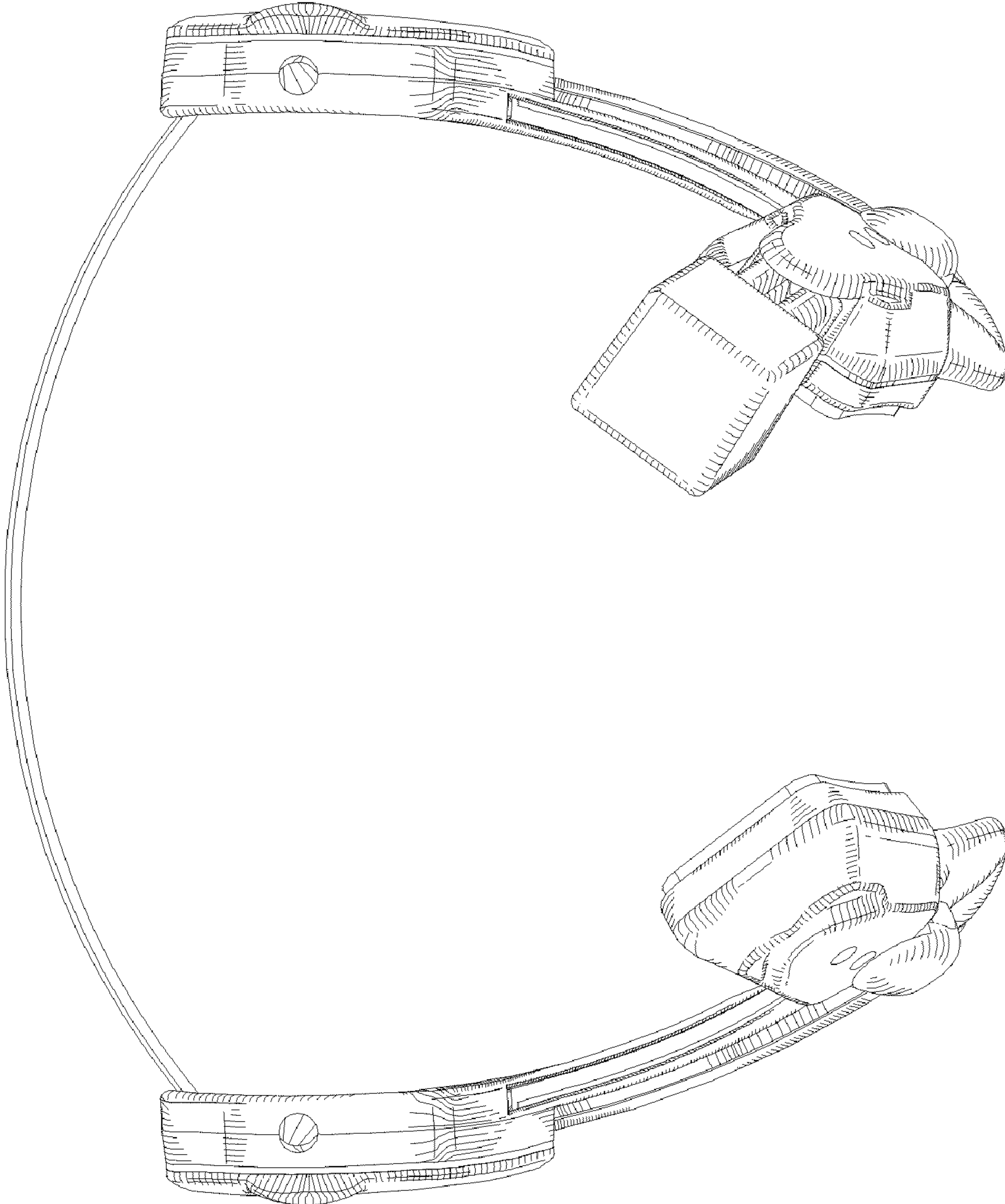

Figure 3

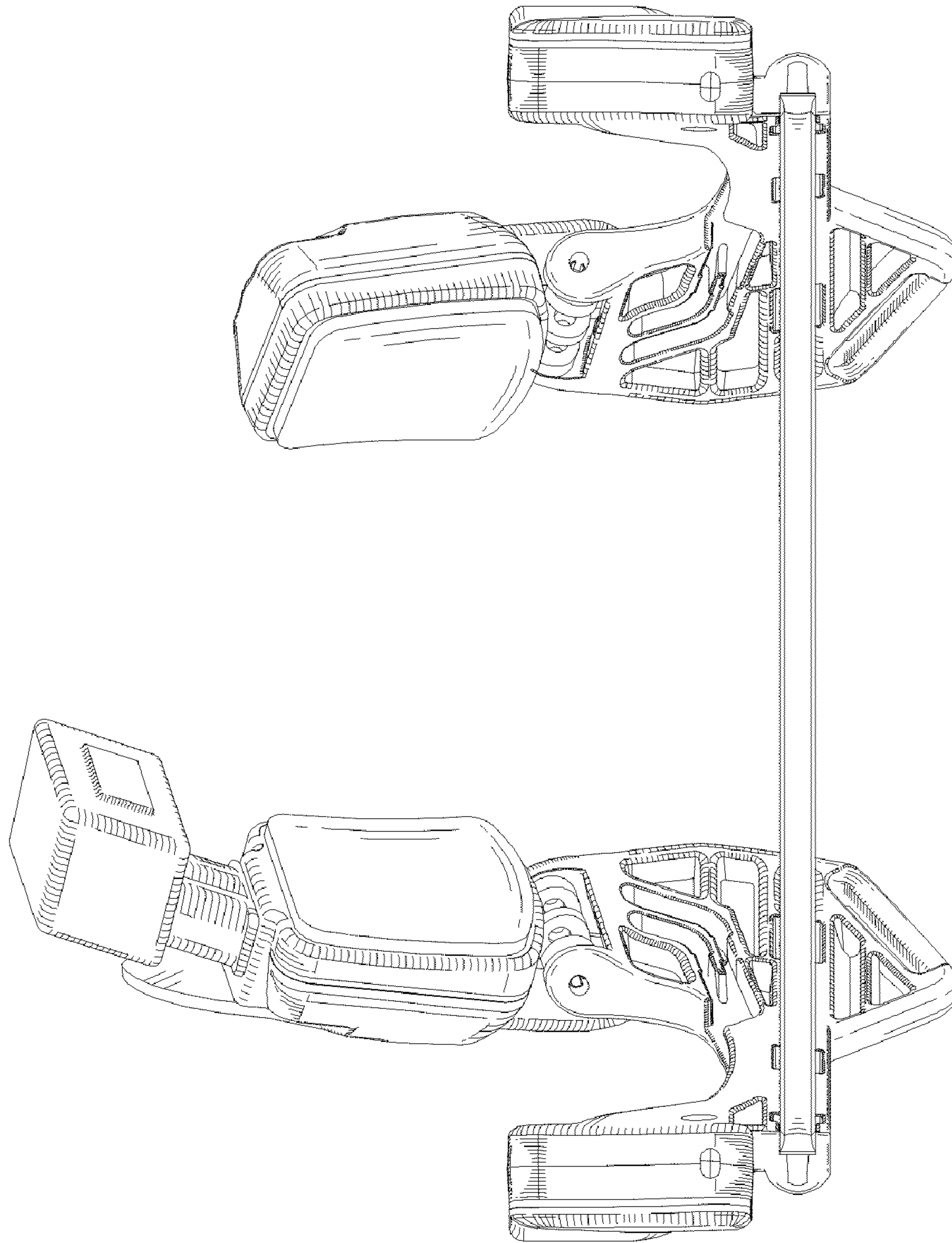

Figure 4

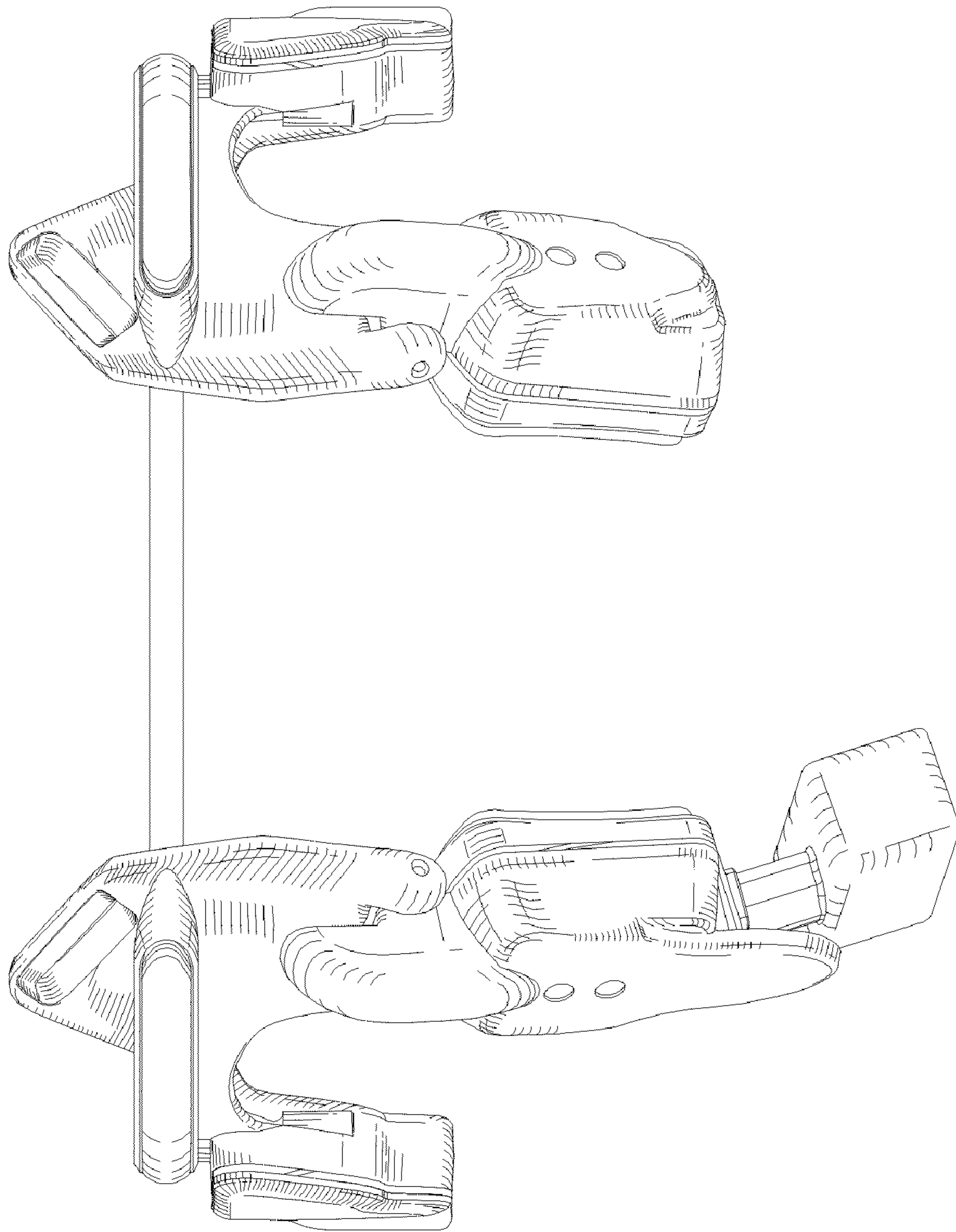

Figure 5

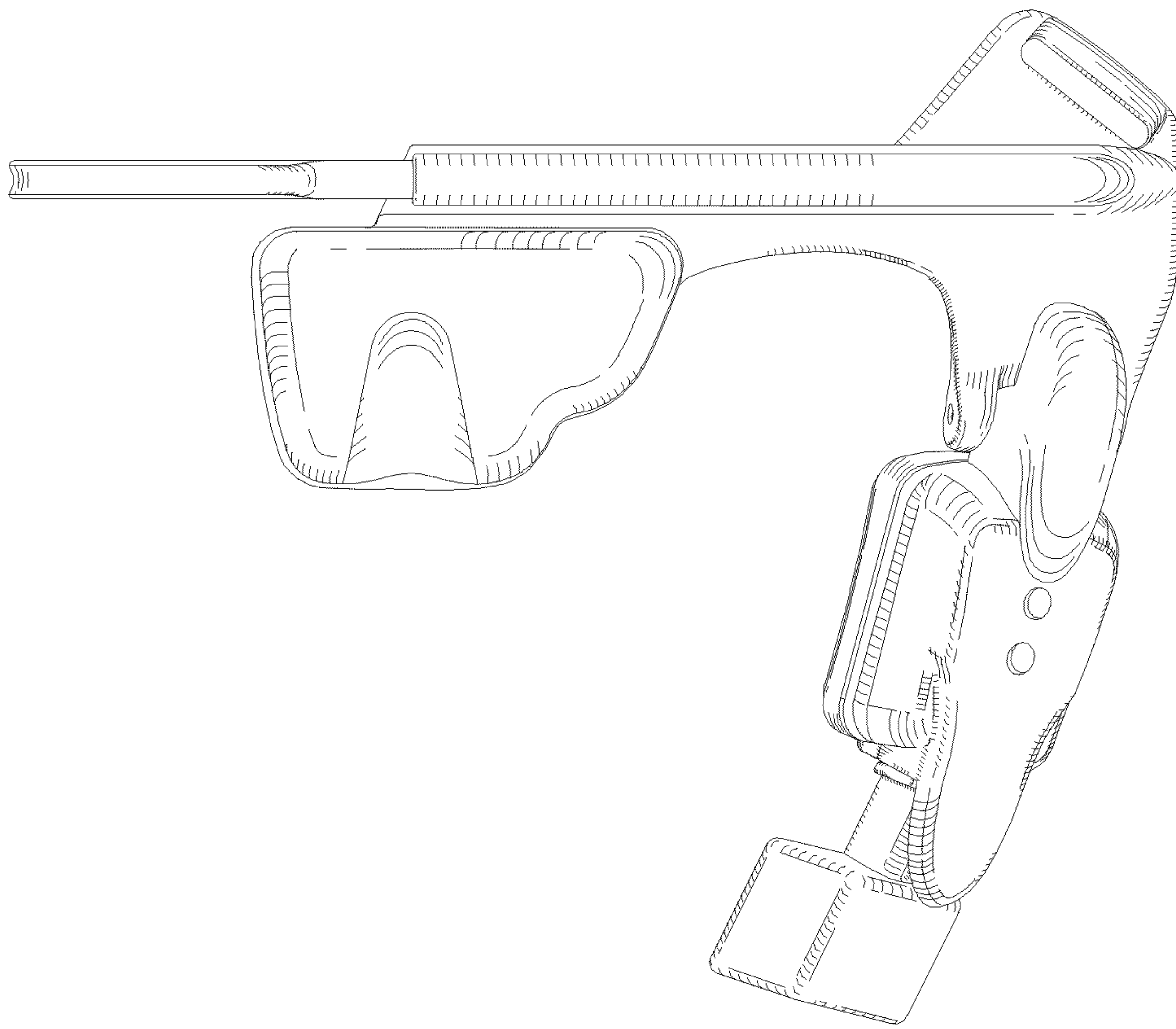

Figure 6

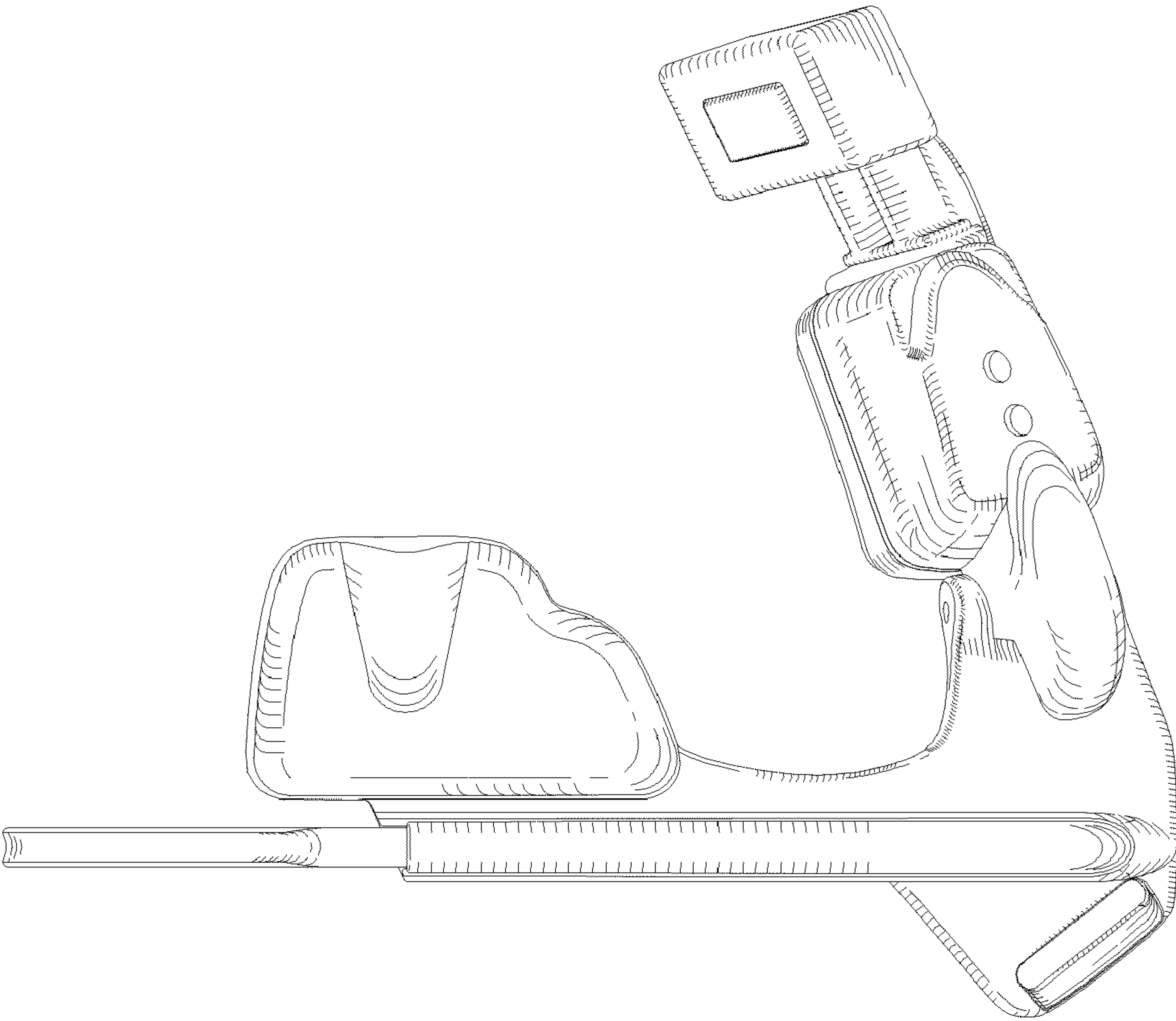

Figure 7

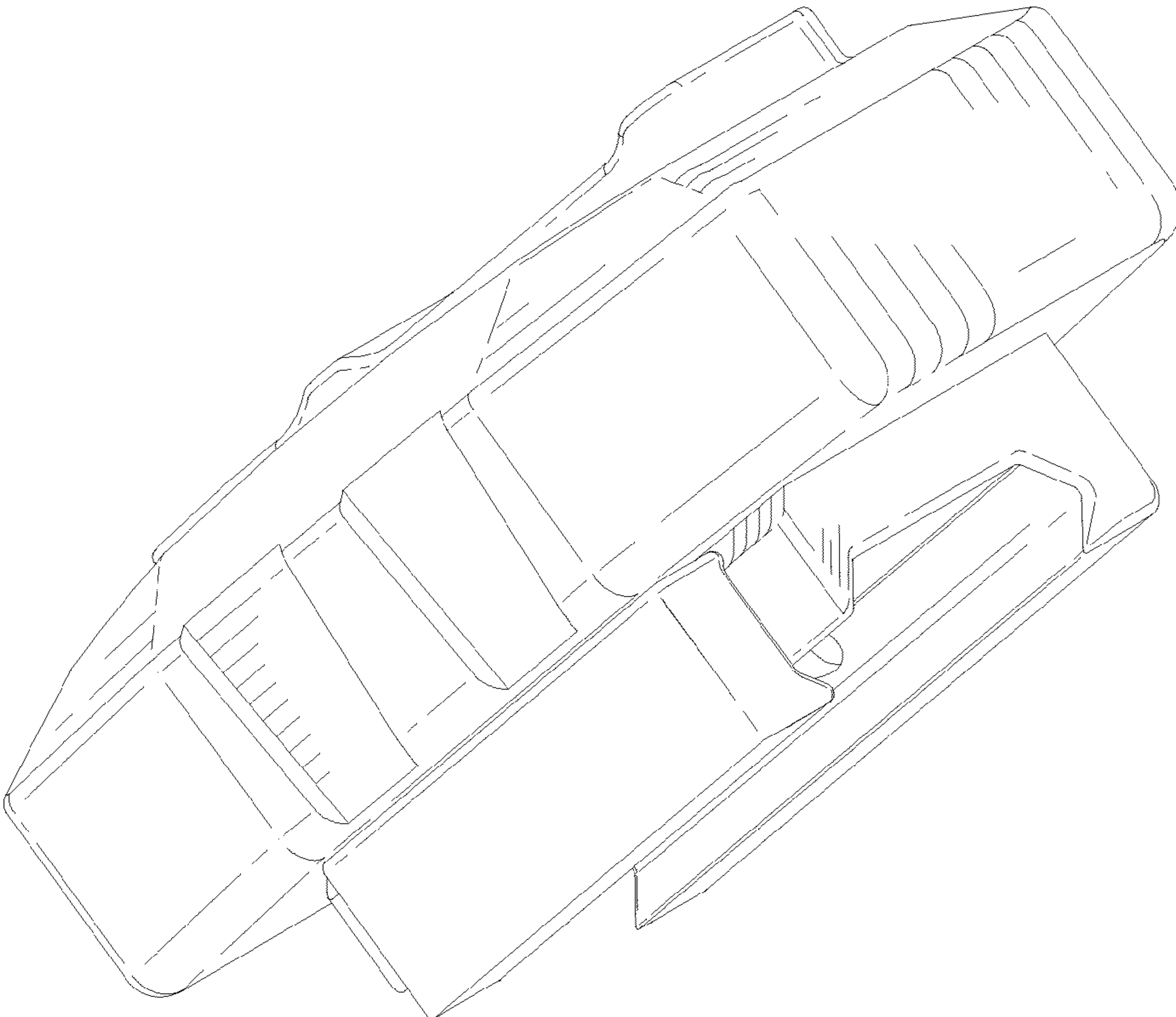

Figure 8

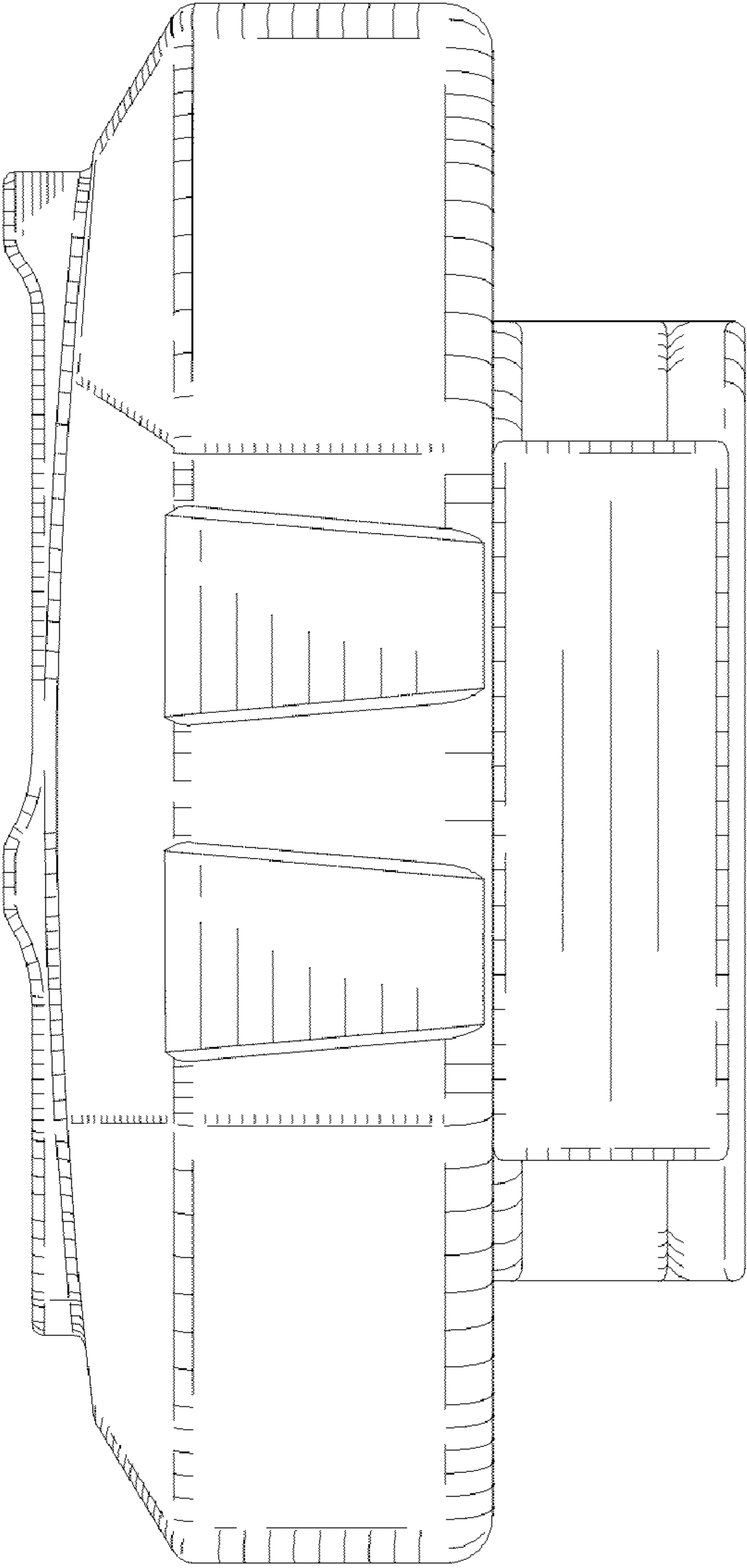

Figure 9

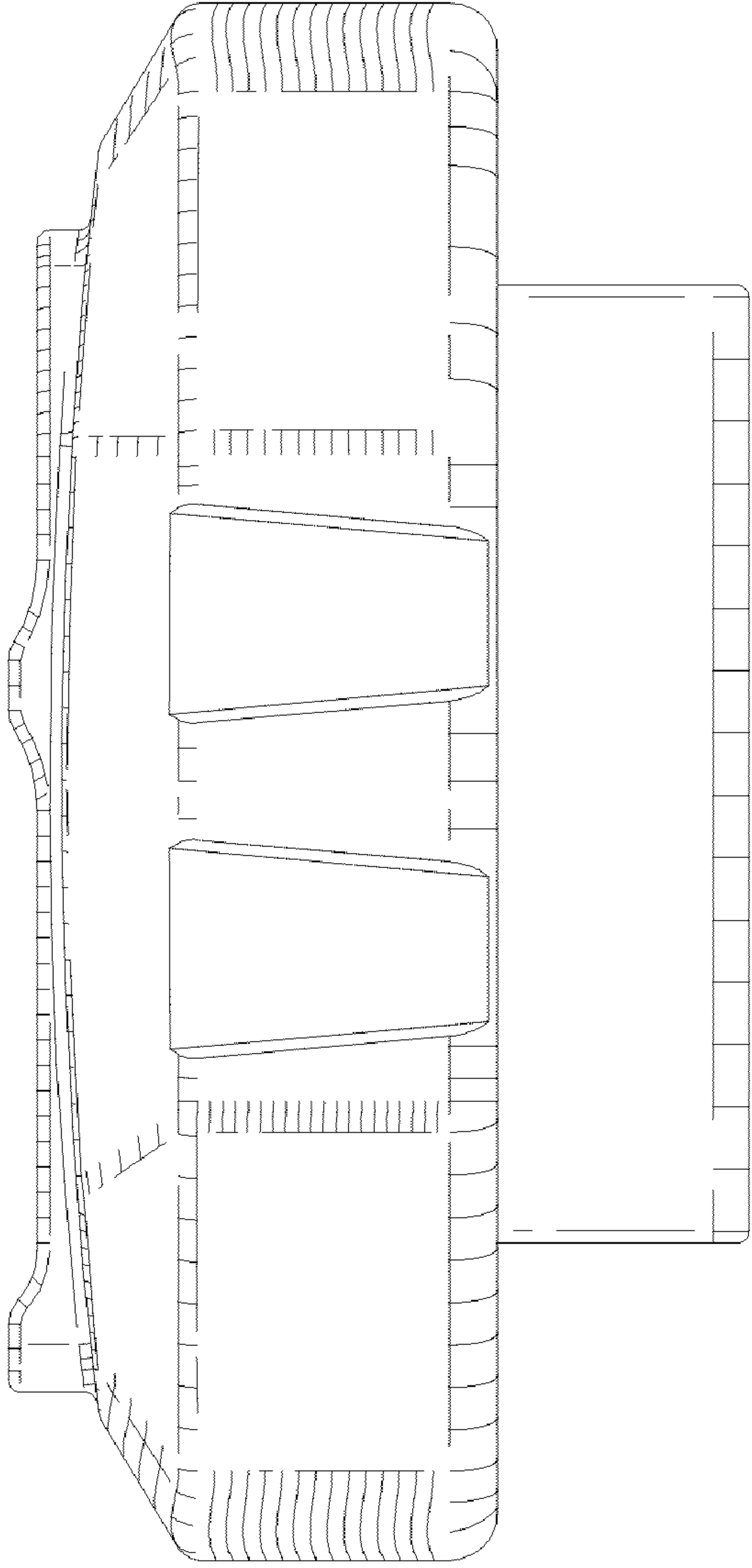

Figure 10

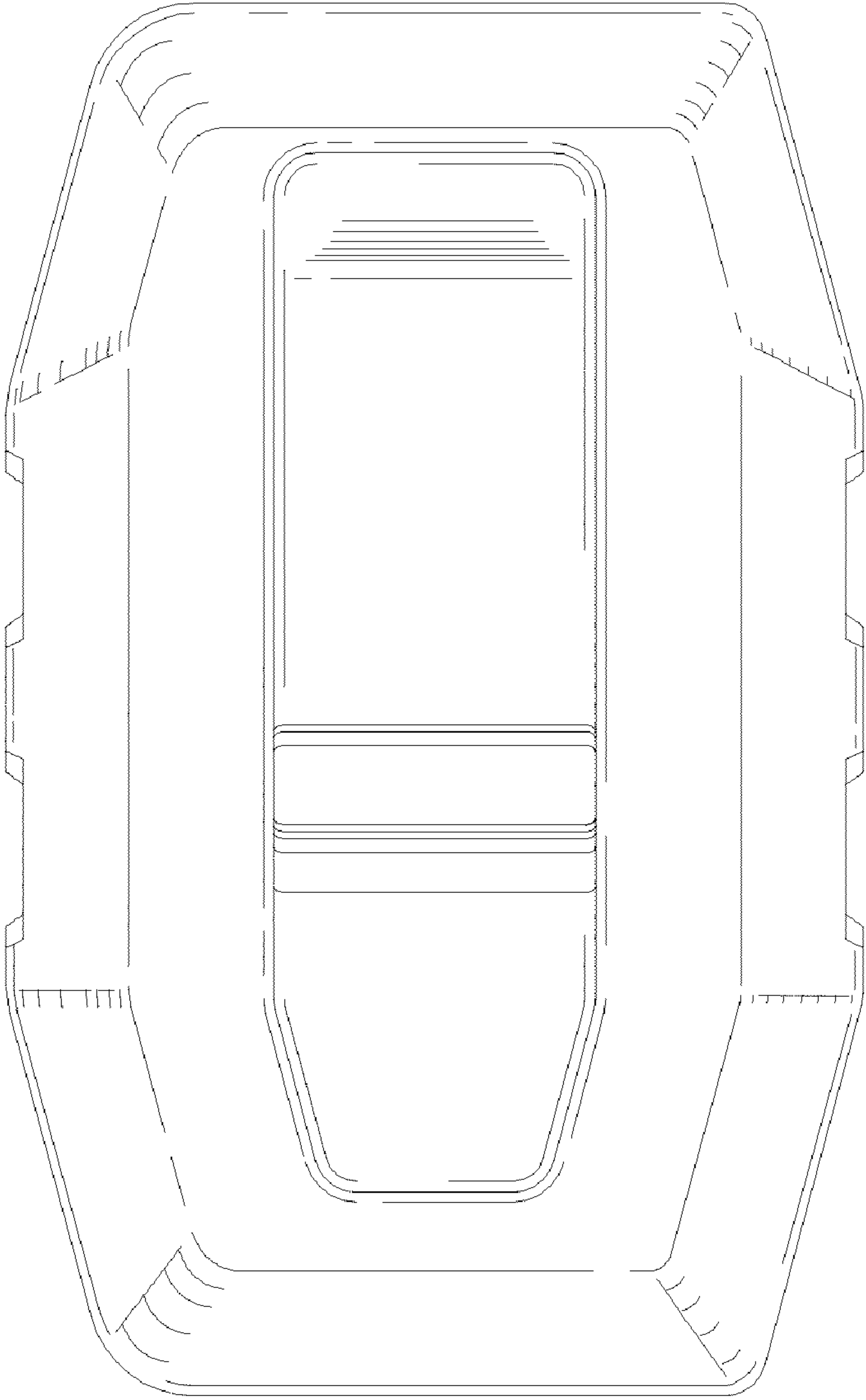

Figure 11

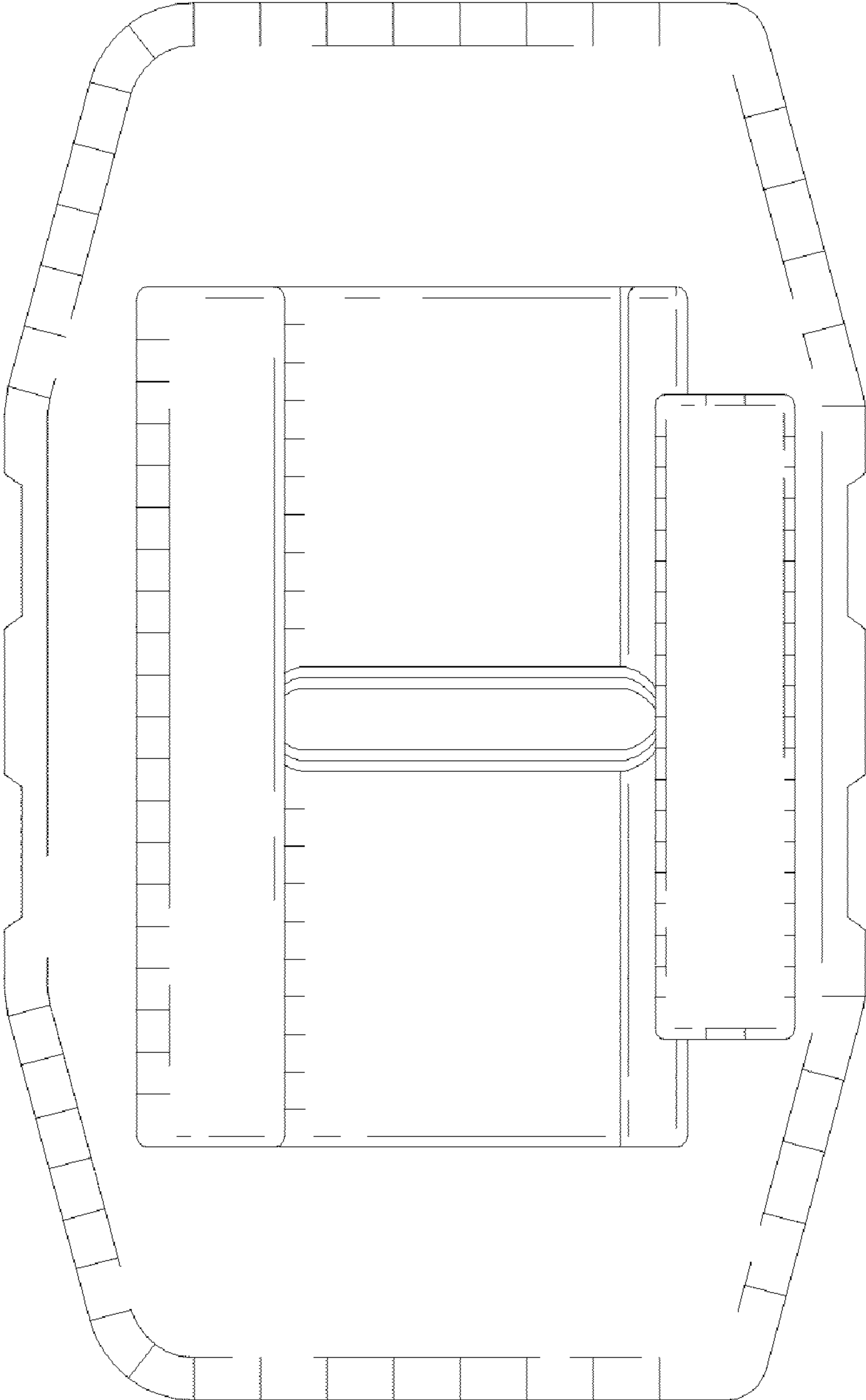

Figure 12

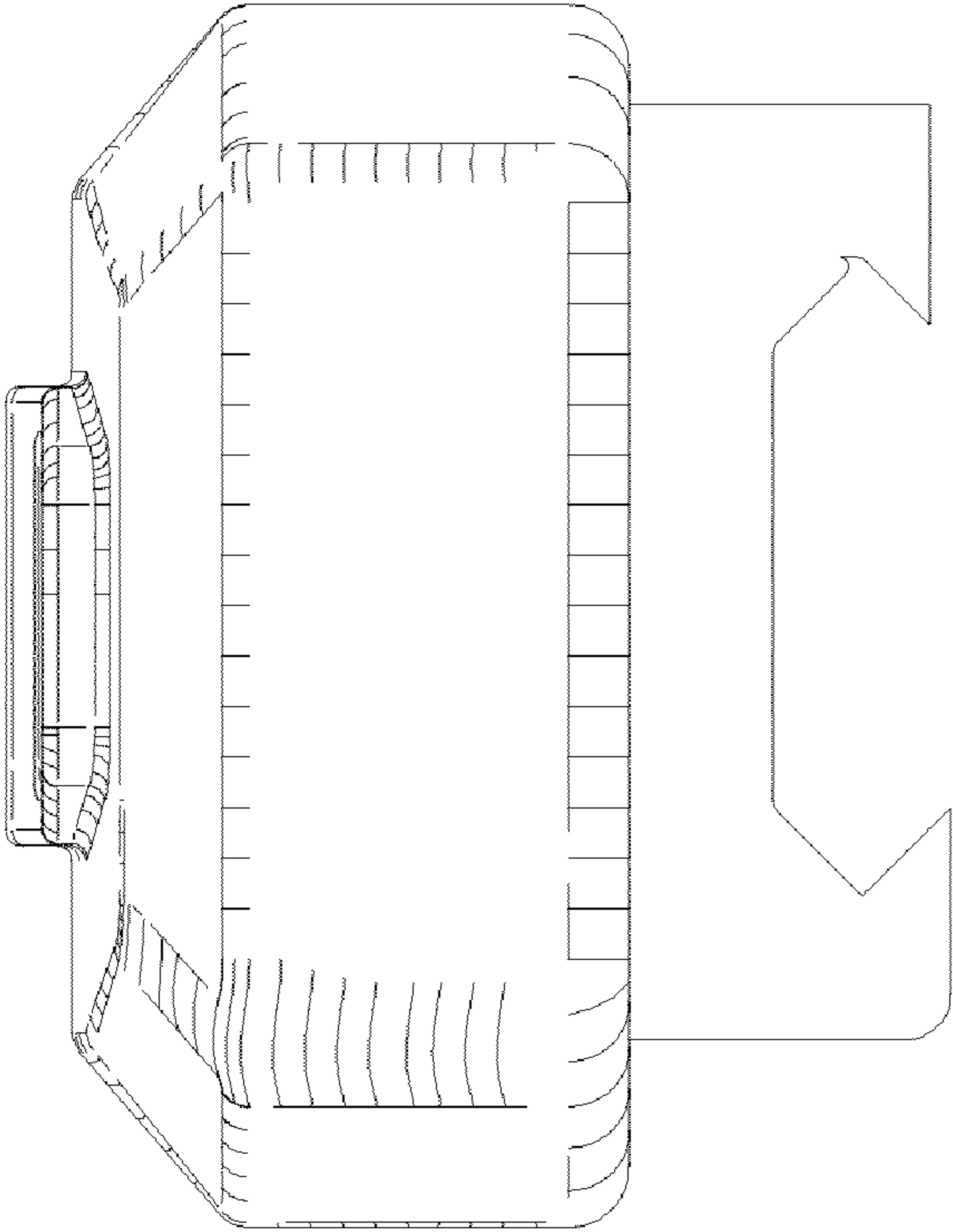

Figure 13

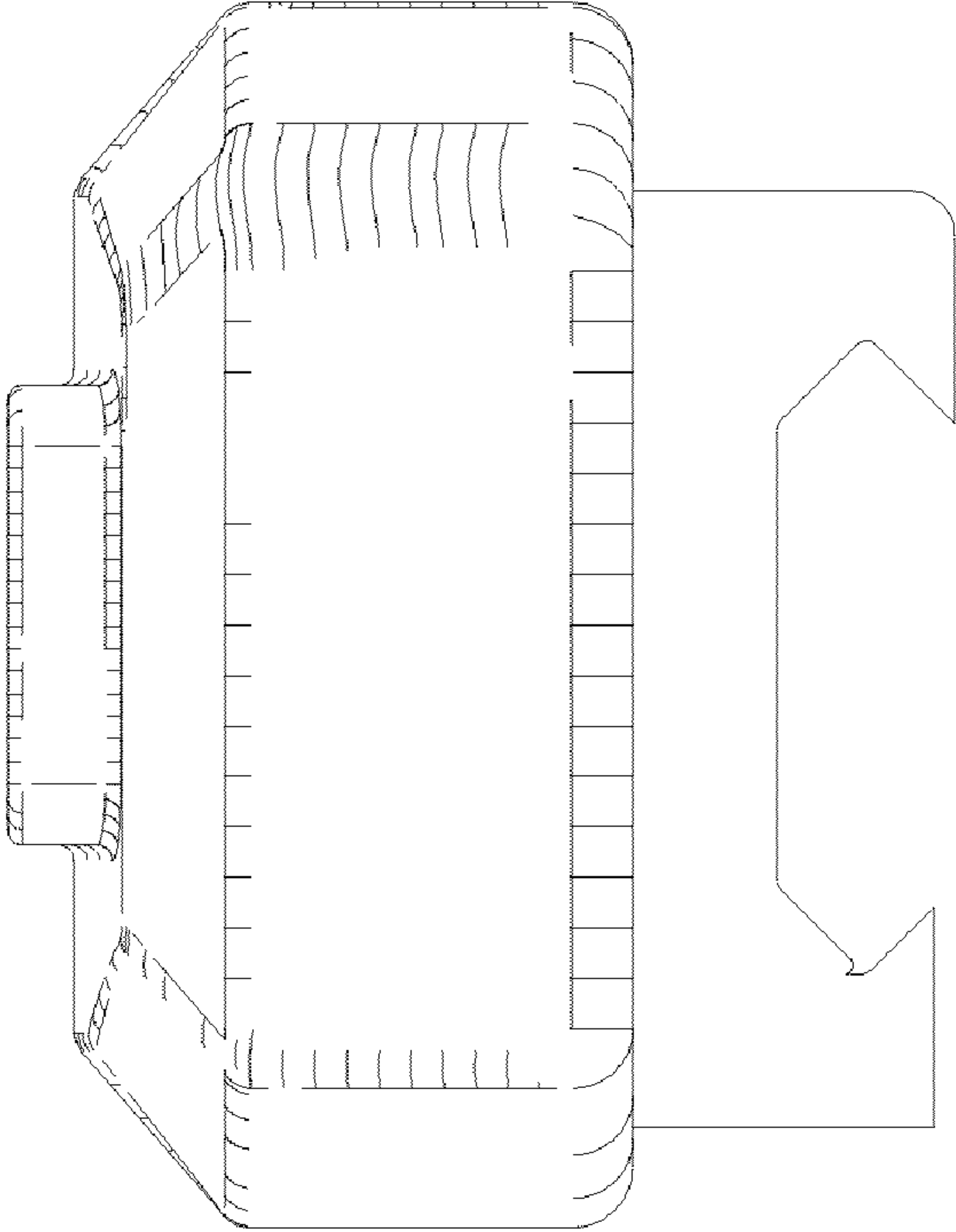

Figure 14

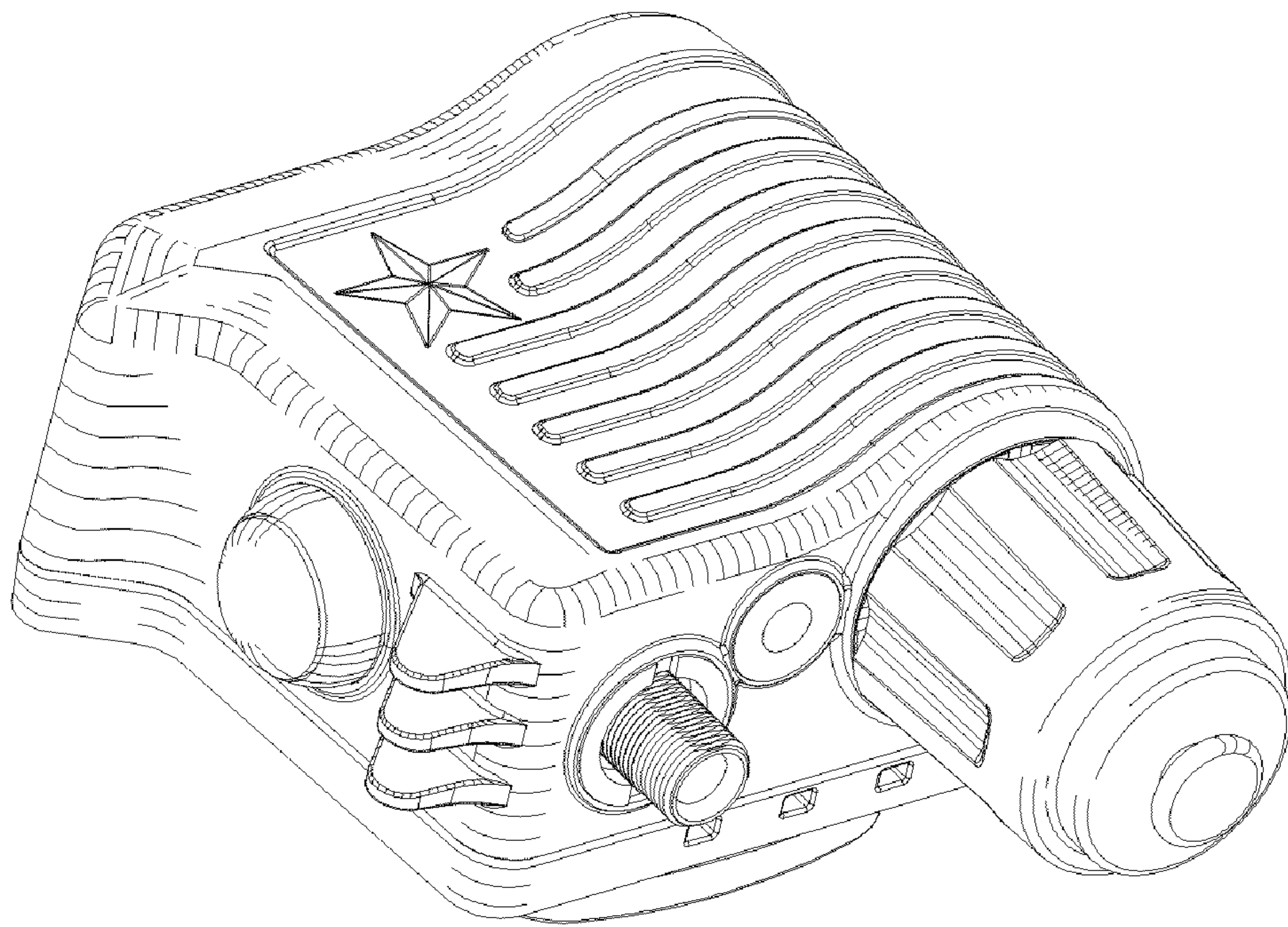

Figure 15

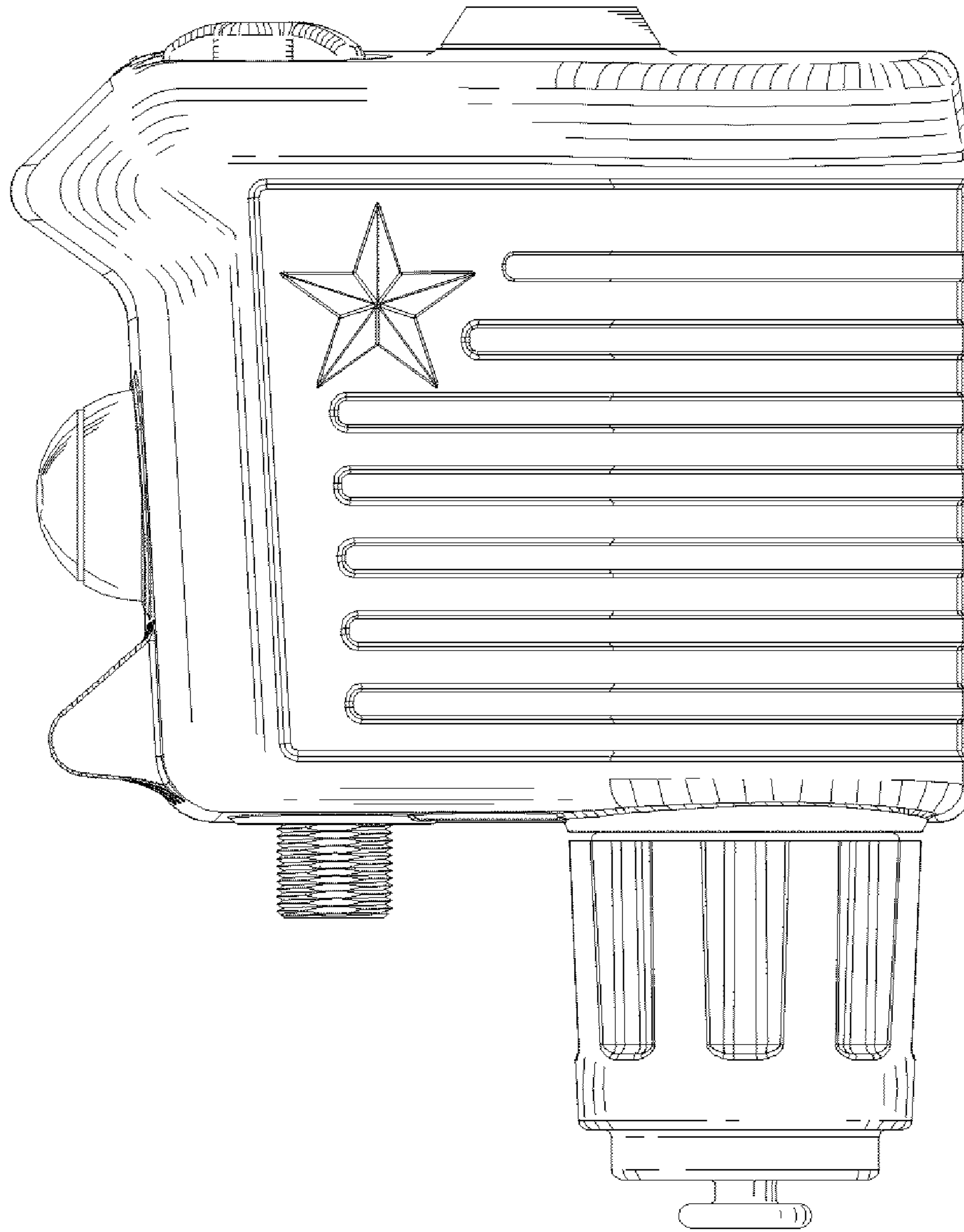

Figure 16

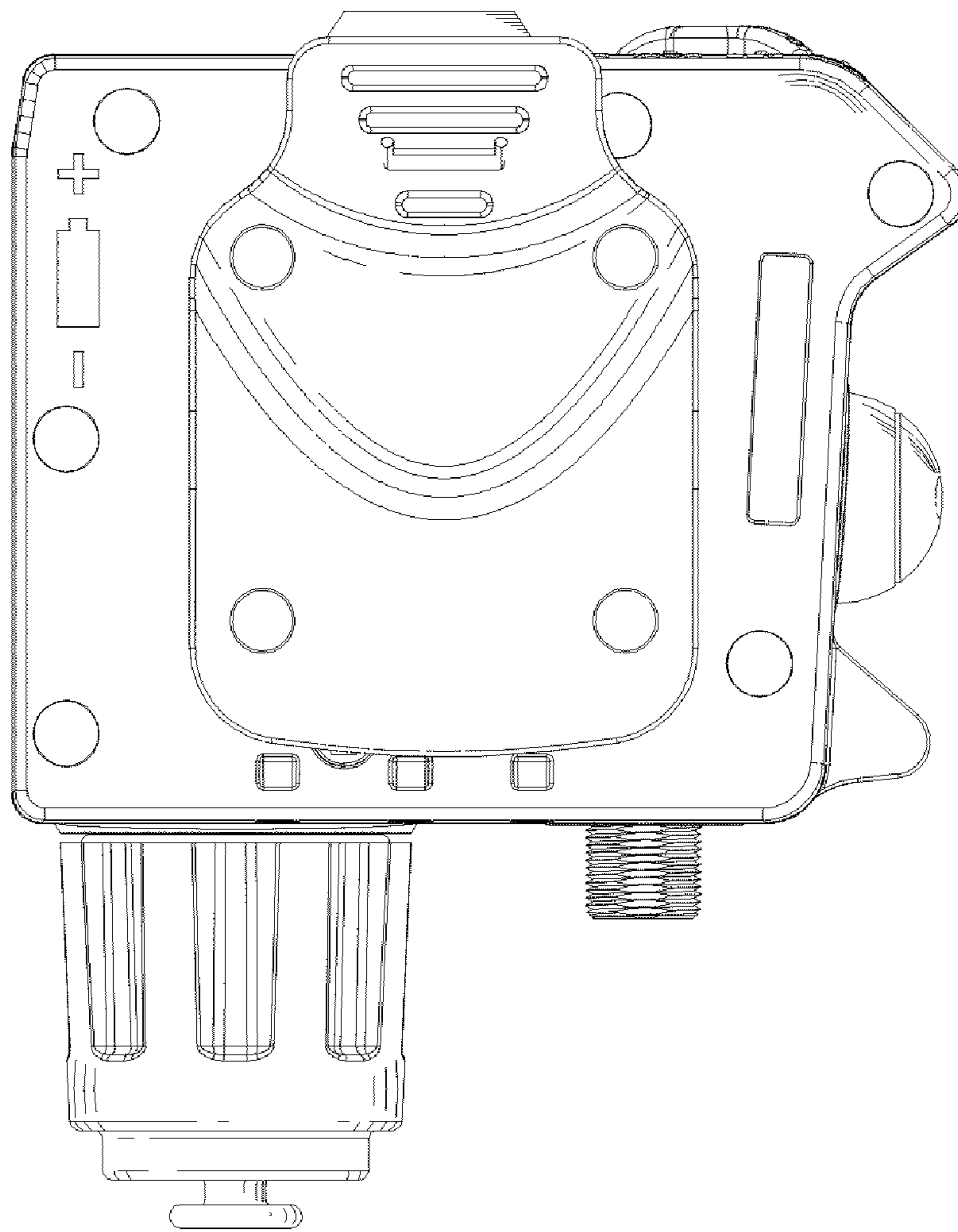

Figure 17

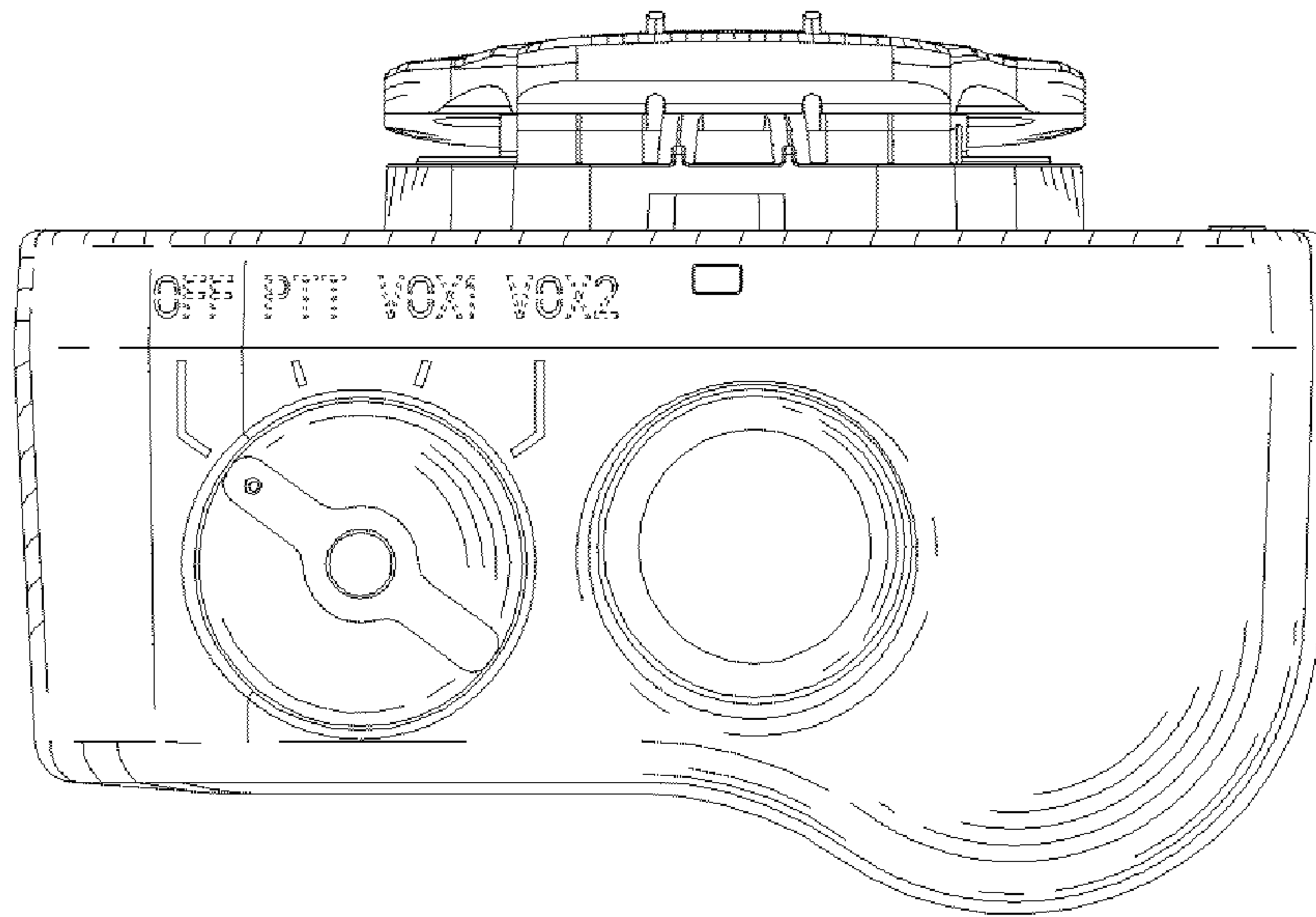

Figure 18

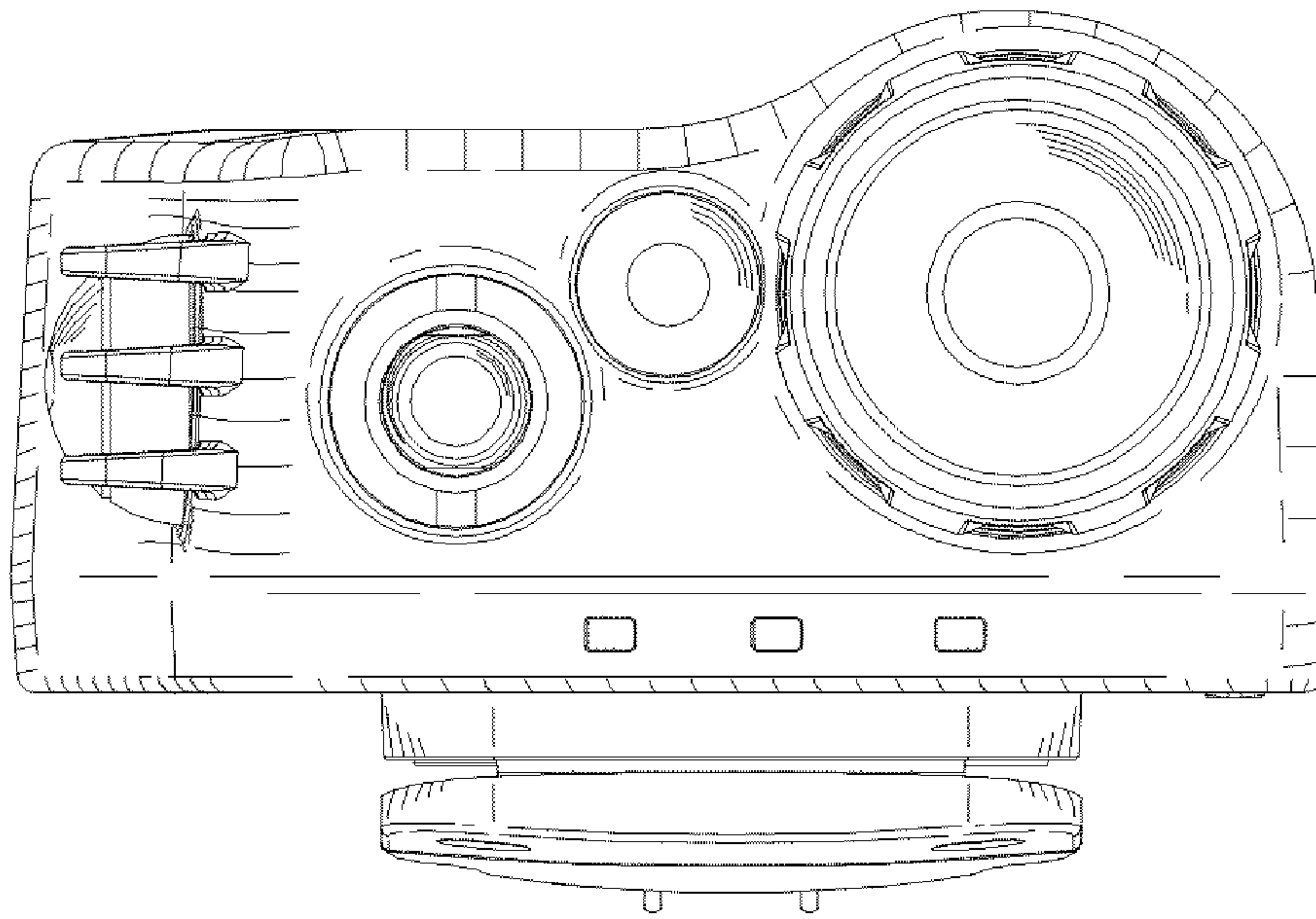

Figure 19

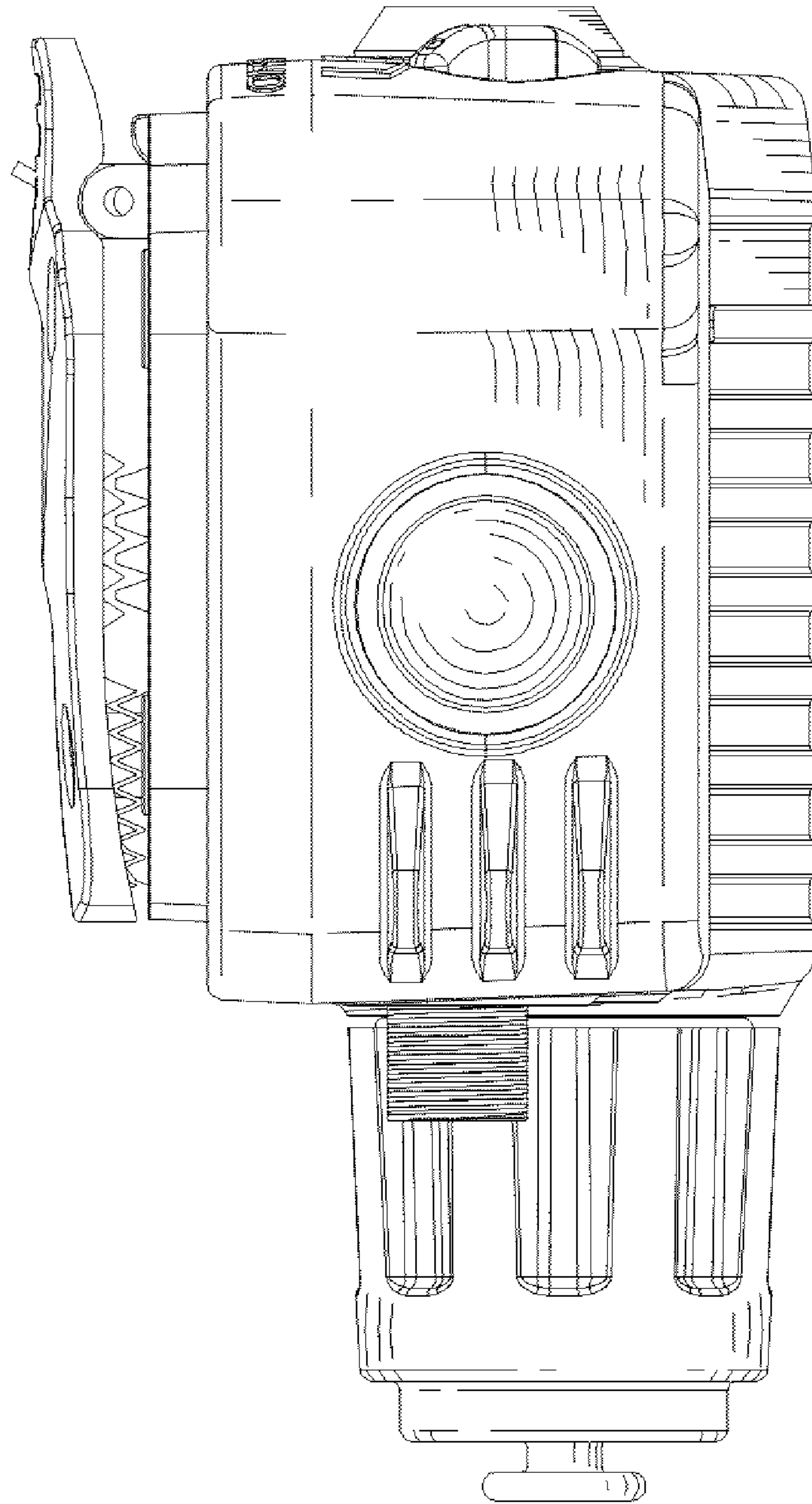

Figure 20

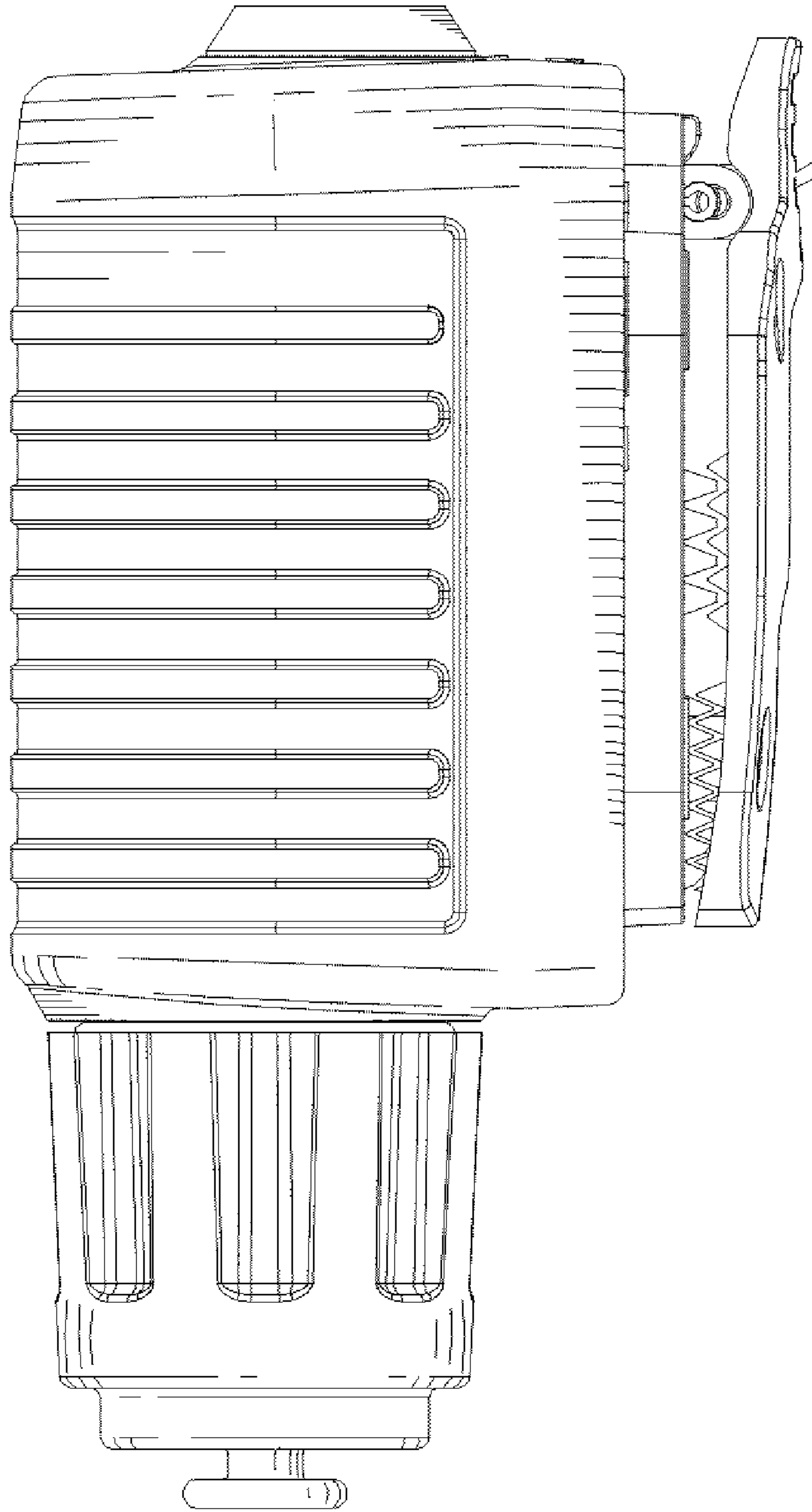

Figure 21