



US00D644147S

(12) **United States Design Patent**
Suh et al.

(10) **Patent No.:** **US D644,147 S**

(45) **Date of Patent:** **** Aug. 30, 2011**

(54) **VEHICLE BODY**

(75) Inventors: **Juho Suh**, Wiesbaden (DE); **Frank Saucedo**, Westlake Village, CA (US); **Robert F. McCann**, Newport Coast, CA (US)

(73) Assignee: **GM Global Technology Operations LLC**, Detroit, MI (US)

(**) Term: **14 Years**

(21) Appl. No.: **29/369,348**

(22) Filed: **Sep. 7, 2010**

(51) **LOC (9) Cl.** **12-08**

(52) **U.S. Cl.** **D12/91**

(58) **Field of Classification Search** D12/86,
D12/90-92, 88; D21/424, 433, 434; 296/181.1,
296/181.5

See application file for complete search history.

(56) **References Cited**

U.S. PATENT DOCUMENTS

D629,719 S * 12/2010 Reichman et al. D12/92
D630,132 S * 1/2011 Jang D12/91

D630,972 S * 1/2011 Fujiwara et al. D12/91
D631,397 S * 1/2011 Clottu D12/91
D633,822 S * 3/2011 Cha D12/91

* cited by examiner

Primary Examiner — Melody N Brown

(74) *Attorney, Agent, or Firm* — Reising Ethington P.C.

(57) **CLAIM**

The ornamental design for a vehicle body, as shown and described.

DESCRIPTION

FIG. 1 is a front view of a vehicle body showing the new design;

FIG. 2 is a left front perspective view thereof;

FIG. 3 is a left side view, the right side being a mirror image thereof;

FIG. 4 is a right rear perspective view thereof; and,

FIG. 5 is a rear view thereof.

In the drawings, the elements shown in broken lines are for illustrative purposes only and form no part of the claimed design.

1 Claim, 5 Drawing Sheets

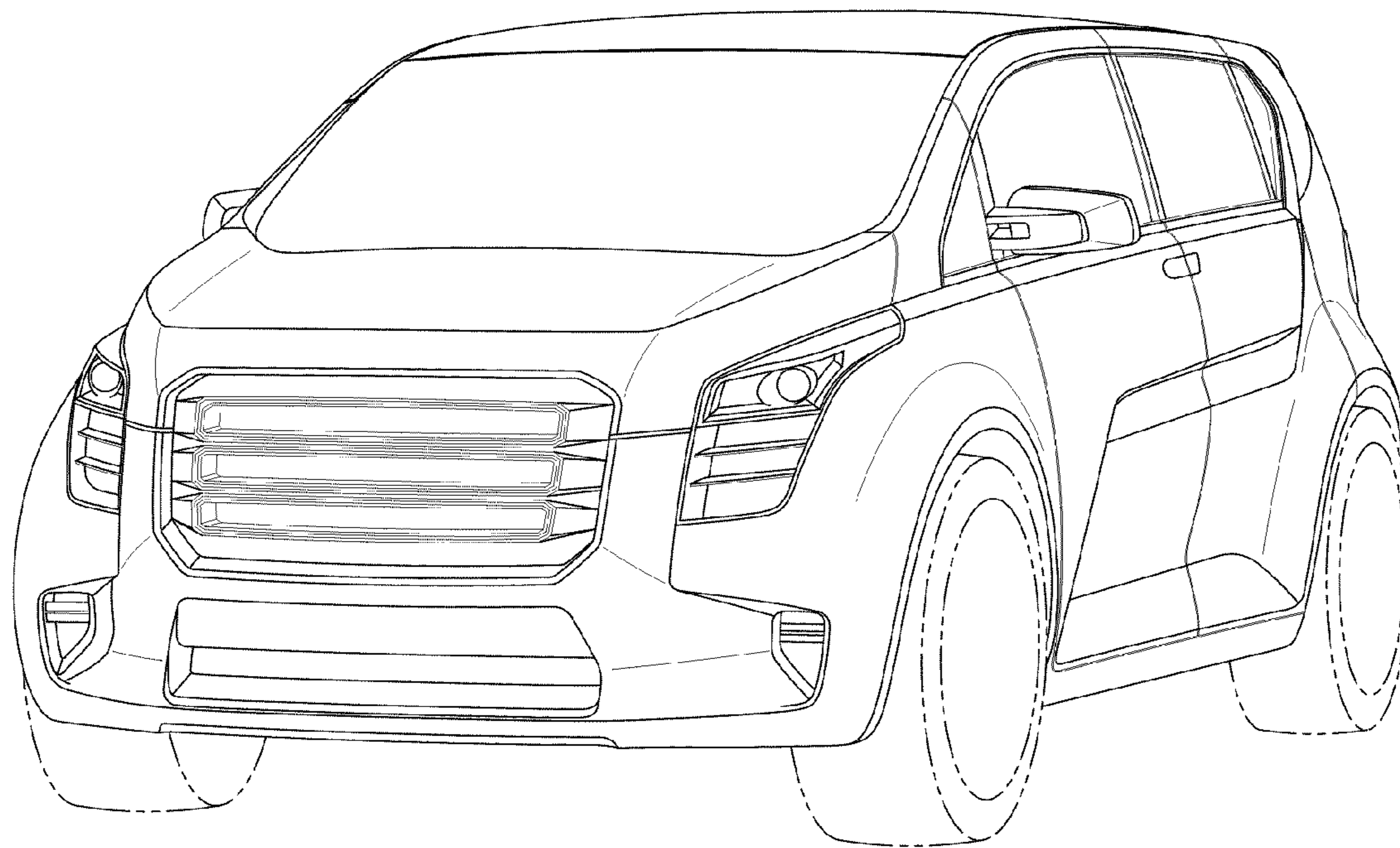

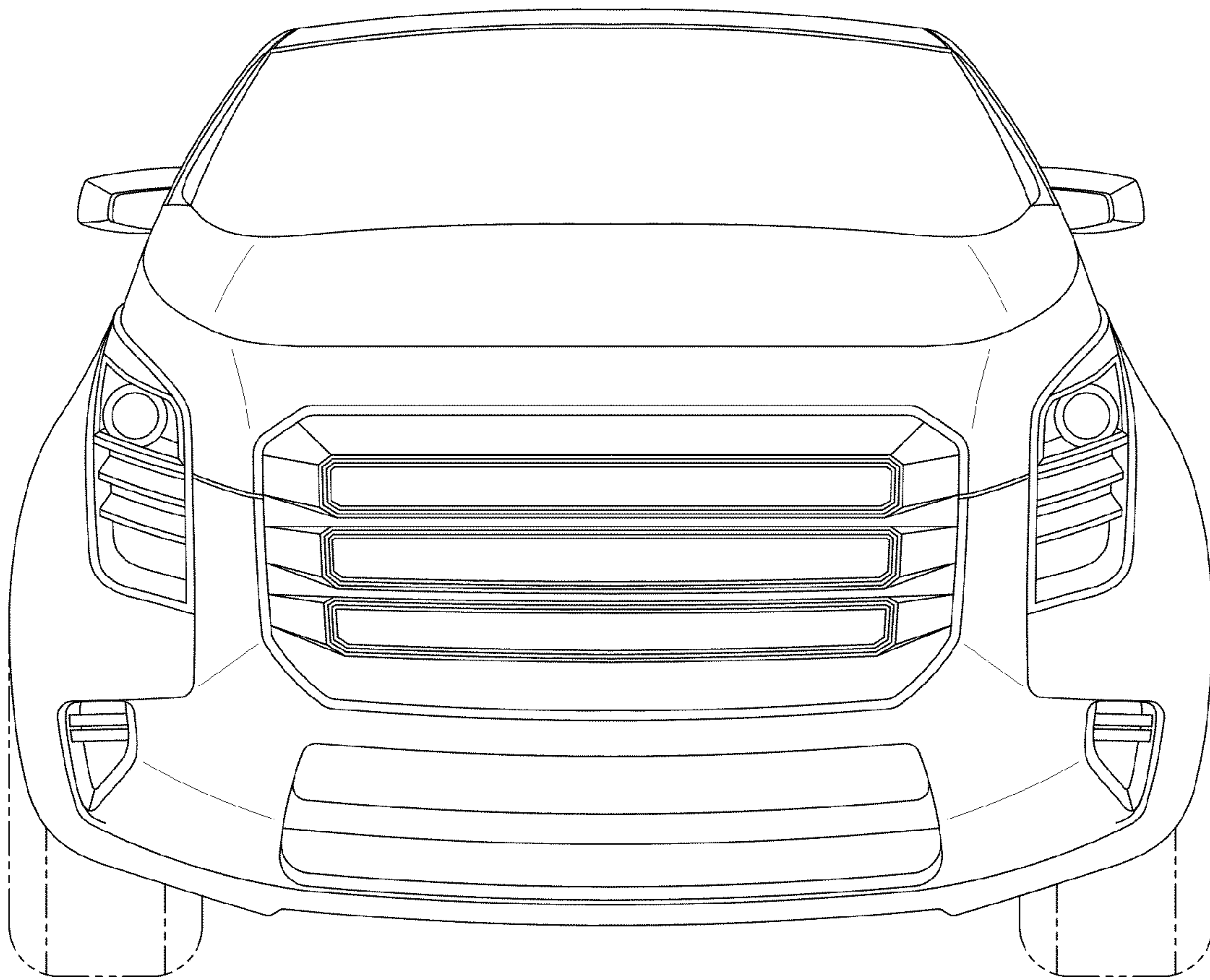

Fig-1

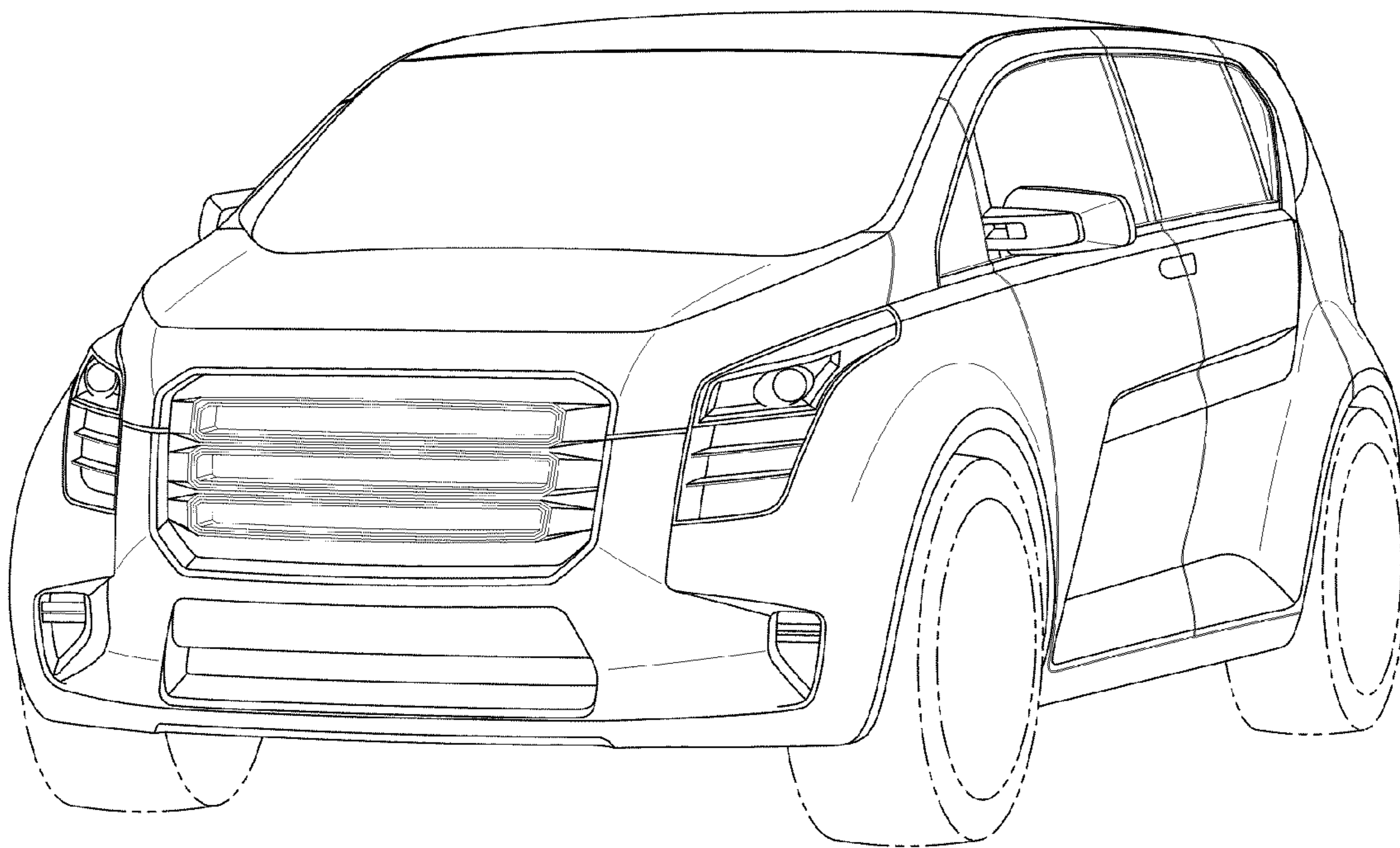

Fig-2

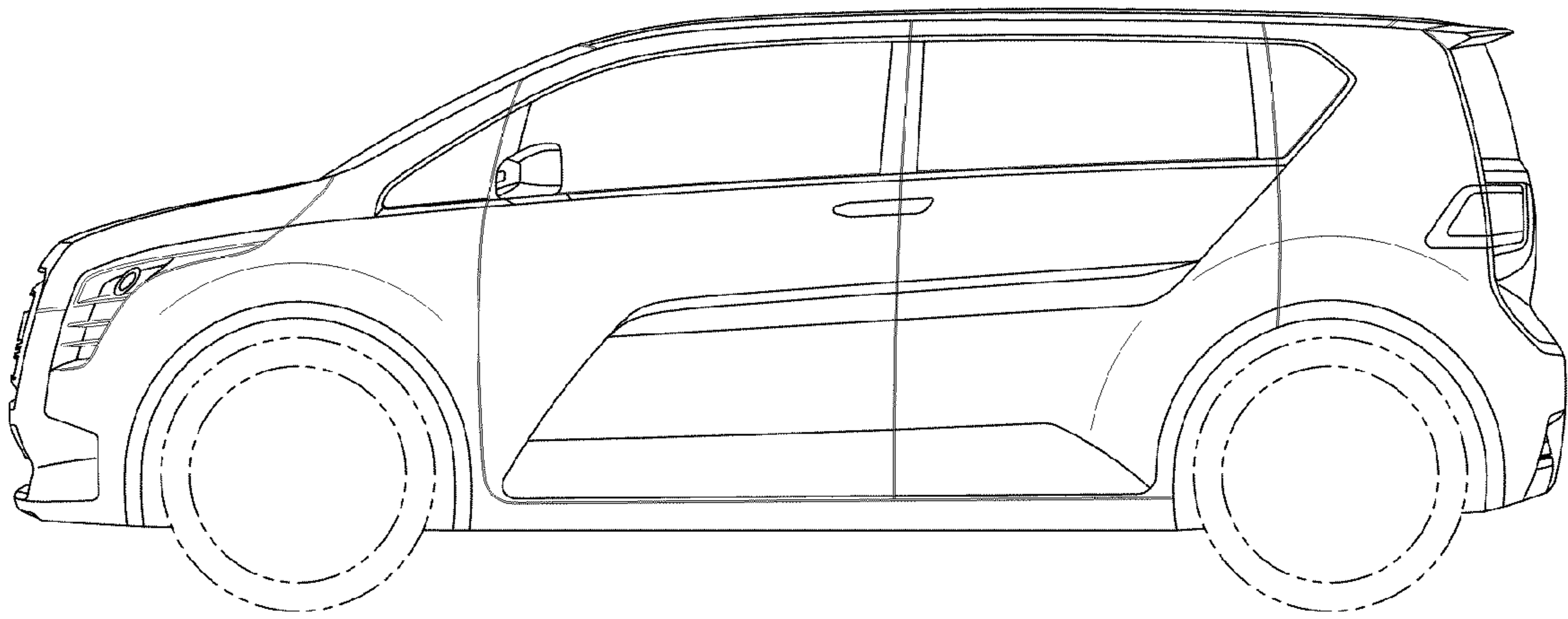

Fig-3

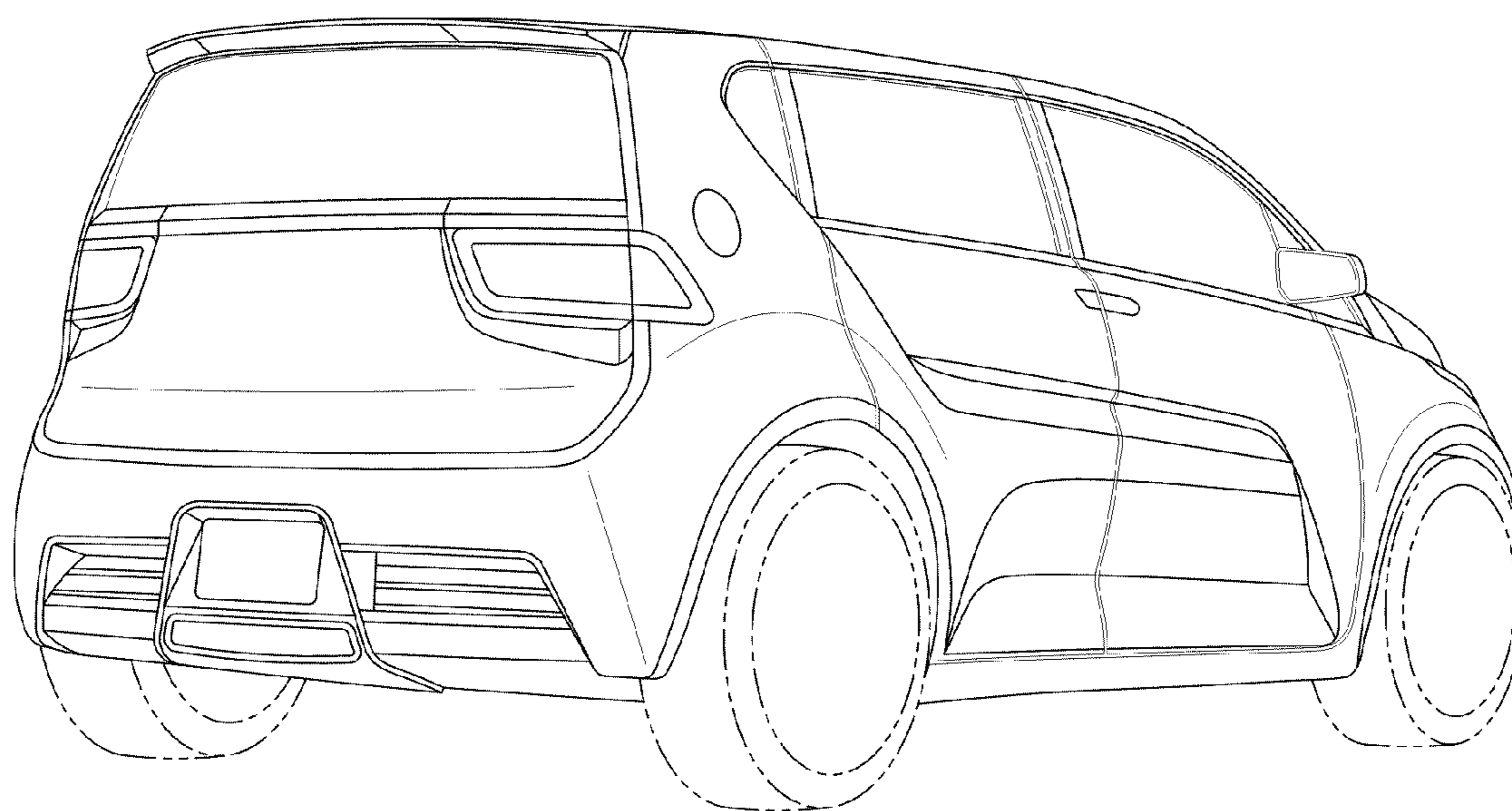

Fig-4

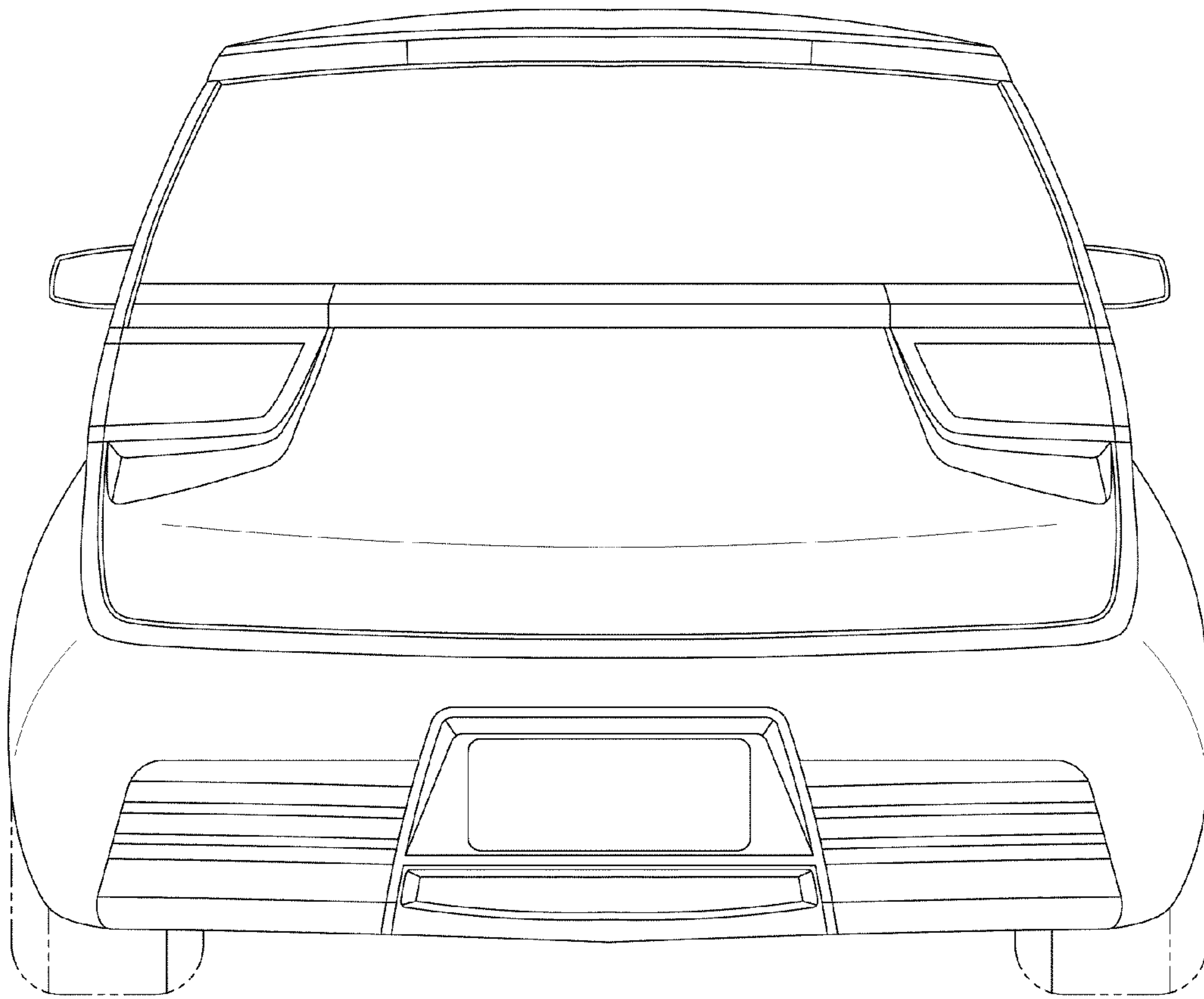

Fig-5