



US00D644057S

(12) **United States Design Patent**  
**Nielsen**

(10) **Patent No.:** **US D644,057 S**

(45) **Date of Patent:** **\*\* Aug. 30, 2011**

(54) **STORAGE APPARATUS FOR MULTIMEDIA ITEMS**

D622,981 S \* 9/2010 Nielsen ..... D6/457  
D625,124 S \* 10/2010 Campbell ..... D6/457  
D634,943 S \* 3/2011 Nielsen ..... D6/407

(75) Inventor: **Britta Claire Nielsen**, Seattle, WA (US)

\* cited by examiner

(73) Assignee: **Whalen Furniture Manufacturing, Inc.**, San Diego, CA (US)

*Primary Examiner* — Elizabeth Albert

*Assistant Examiner* — Kelley Donnelly

(\*\*) Term: **14 Years**

(74) *Attorney, Agent, or Firm* — Barlow, Josephs & Holmes, Ltd.

(21) Appl. No.: **29/386,406**

(22) Filed: **Feb. 28, 2011**

(57) **CLAIM**

The ornamental design for a storage apparatus for multimedia items, as shown and described.

(51) **LOC (9) Cl.** ..... **06-04**

(52) **U.S. Cl.** ..... **D6/629**

(58) **Field of Classification Search** ..... D6/629–630,  
D6/396, 407, 409–416, 449, 462–465; 108/29,  
108/31, 59–60; 211/34, 36–37, 40, 41.12,  
211/42

**DESCRIPTION**

See application file for complete search history.

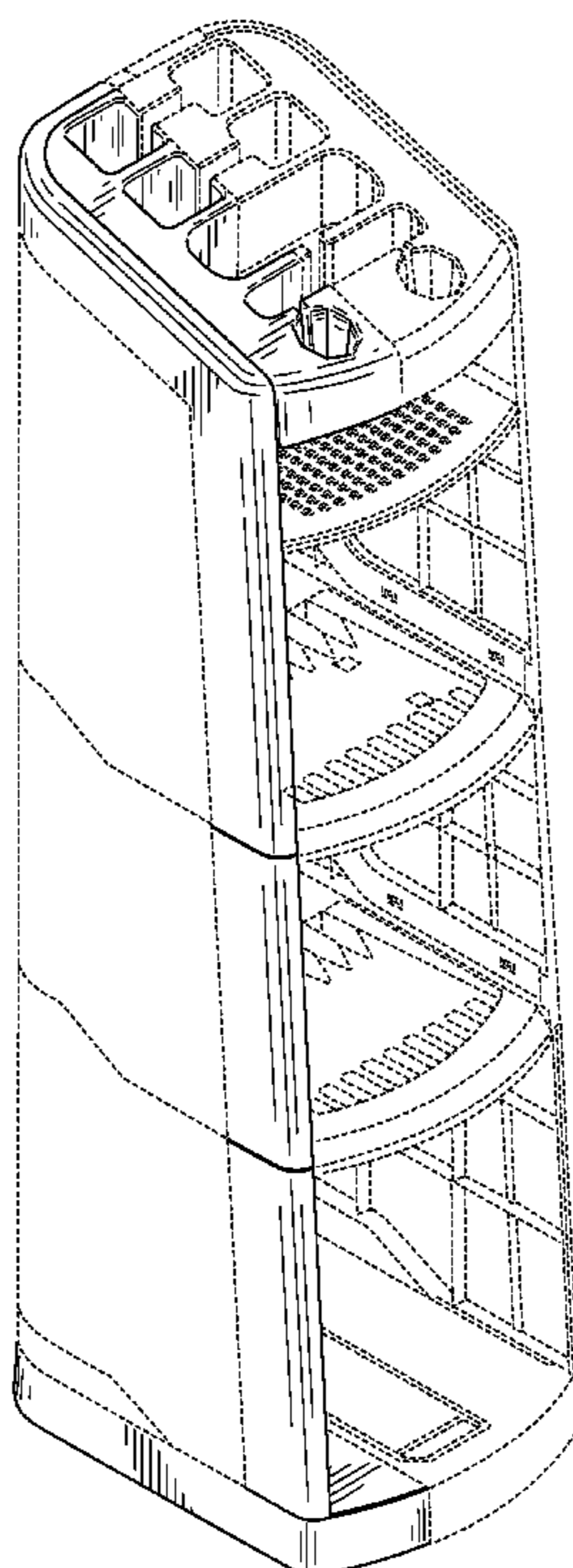
FIG. 1 is a first perspective view of a design for the storage apparatus for multimedia items;  
FIG. 2 is a second perspective view of the design therefor;  
FIG. 3 is a first side view of the design therefor;  
FIG. 4 is a second side view of the design therefor, opposite the first side view;  
FIG. 5 is a front side view of the design therefor;  
FIG. 6 is a rear side view of the design therefor, opposite the front side view;  
FIG. 7 is a top plan view of the design therefor; and,  
FIG. 8 is a bottom plan view of the design therefor.  
The dashed lines in the drawings are shown for environmental purposes and form no part of the claimed design.  
The heavy dashed lines that define the bounds of the claimed design form no part thereof.

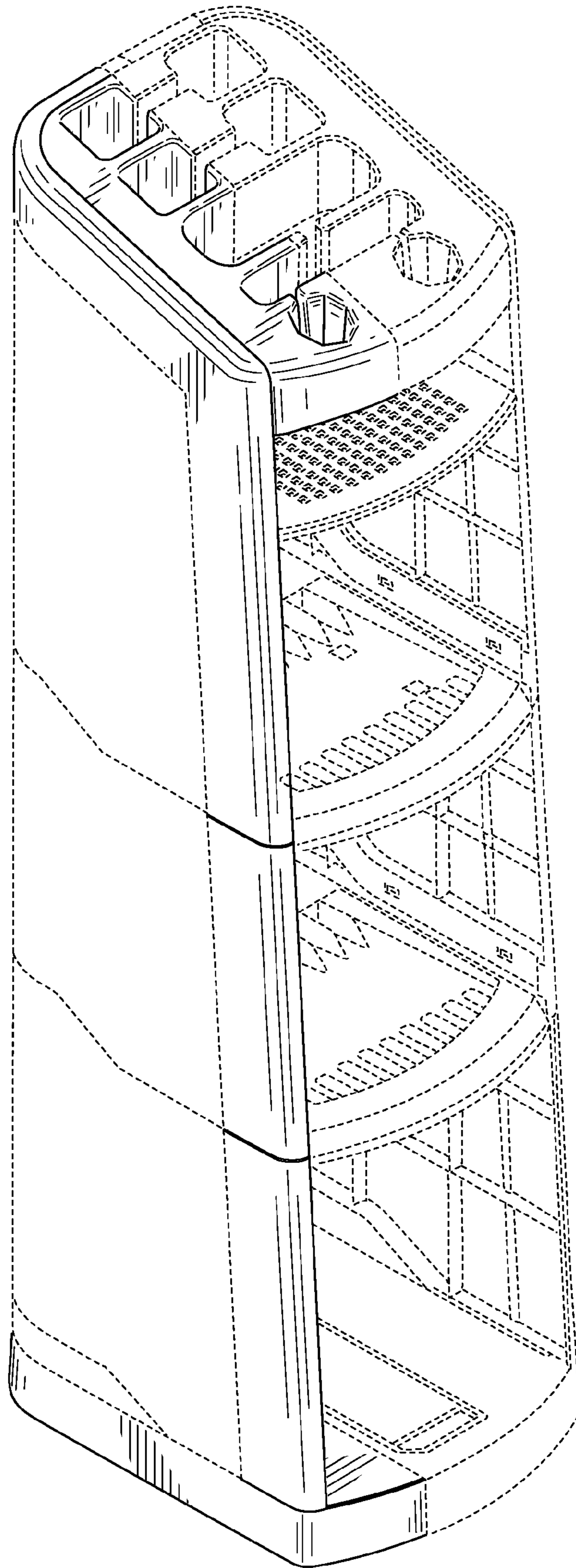
(56) **References Cited**

U.S. PATENT DOCUMENTS

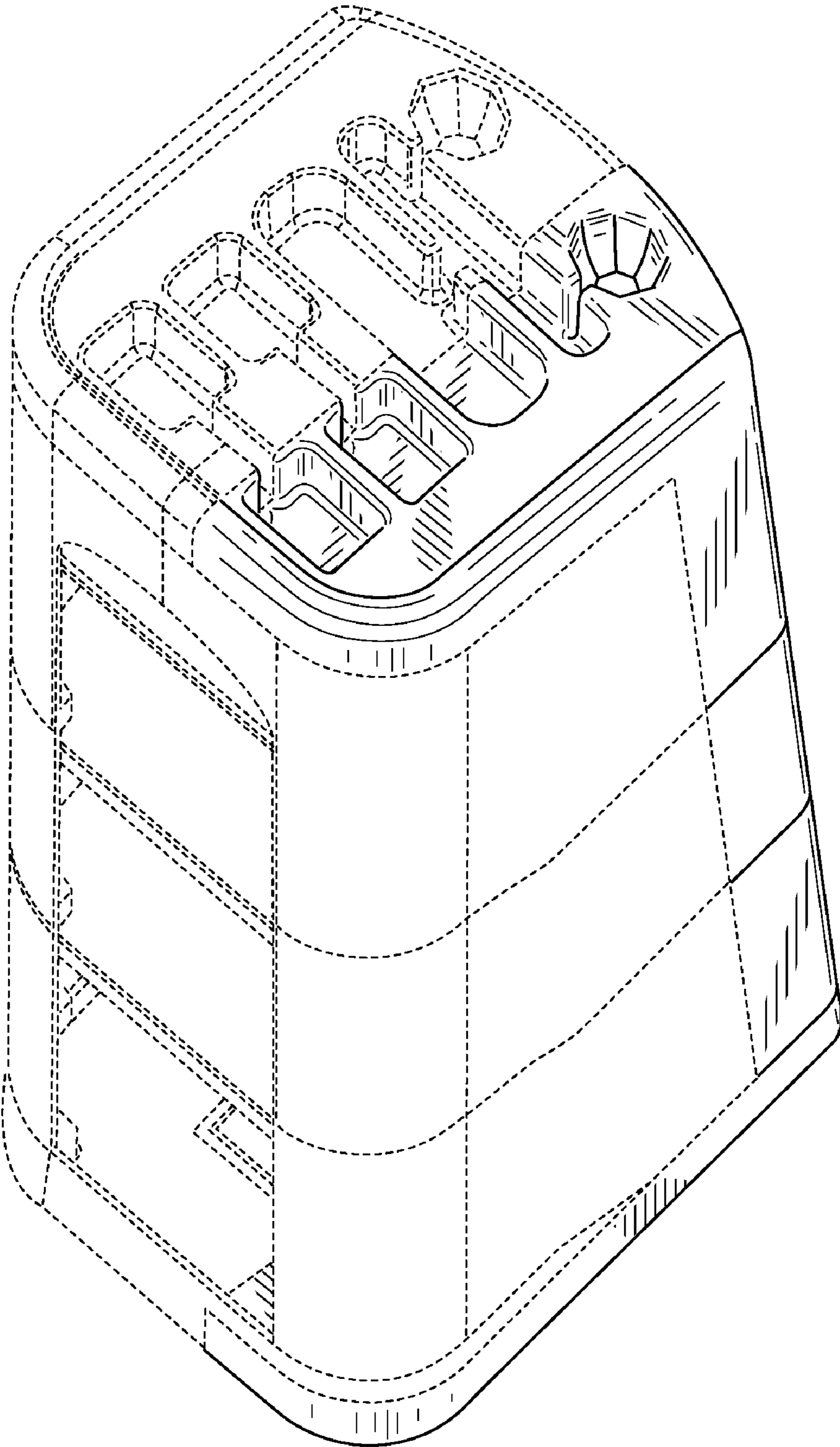
|           |   |   |         |              |       |        |
|-----------|---|---|---------|--------------|-------|--------|
| 4,345,802 | A | * | 8/1982  | Sorensen     | ..... | 312/42 |
| D409,865  | S | * | 5/1999  | West         | ..... | D6/509 |
| D452,389  | S | * | 12/2001 | Scala et al. | ..... | D6/408 |
| D528,341  | S | * | 9/2006  | Lau          | ..... | D6/630 |
| D610,371  | S | * | 2/2010  | Nielsen      | ..... | D6/457 |
| D616,220  | S | * | 5/2010  | Nielsen      | ..... | D6/457 |
| D616,221  | S | * | 5/2010  | Nielsen      | ..... | D6/457 |
| D616,222  | S | * | 5/2010  | Kohler       | ..... | D6/457 |
| D616,223  | S | * | 5/2010  | Nielsen      | ..... | D6/457 |
| D618,480  | S | * | 6/2010  | Kohler       | ..... | D6/629 |
| D619,406  | S | * | 7/2010  | Nielsen      | ..... | D6/629 |
| D619,407  | S | * | 7/2010  | Nielsen      | ..... | D6/629 |
| D622,532  | S | * | 8/2010  | Moore        | ..... | D6/629 |

**1 Claim, 7 Drawing Sheets**

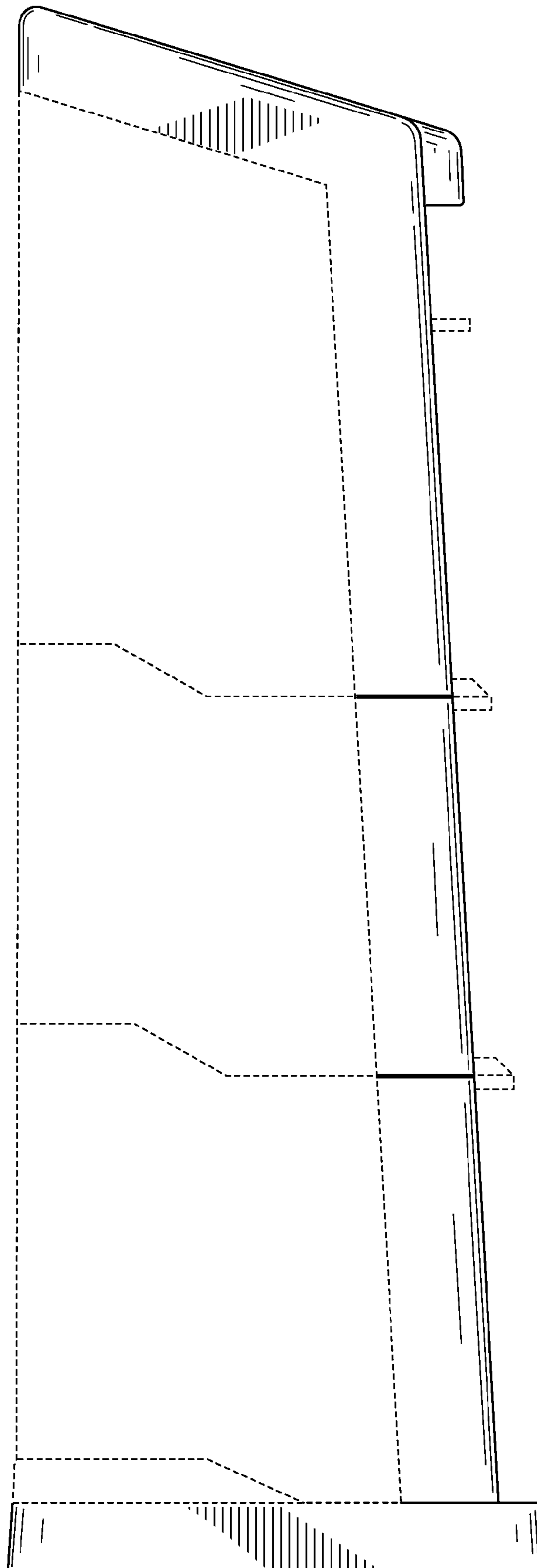




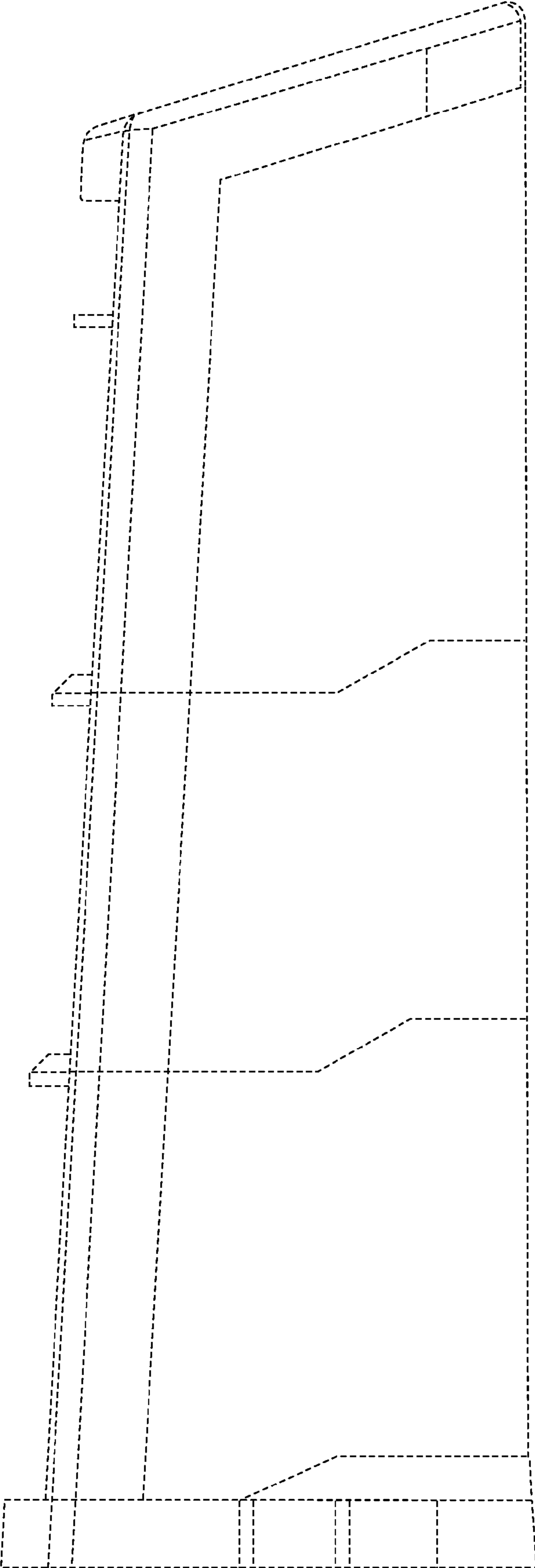
**FIG. 1**



**FIG. 2**

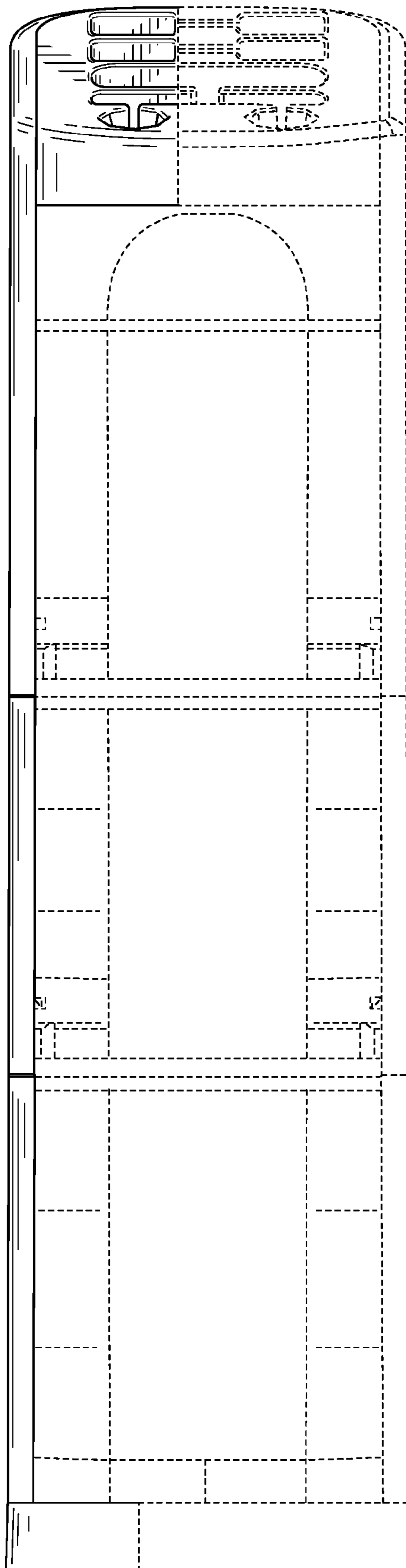


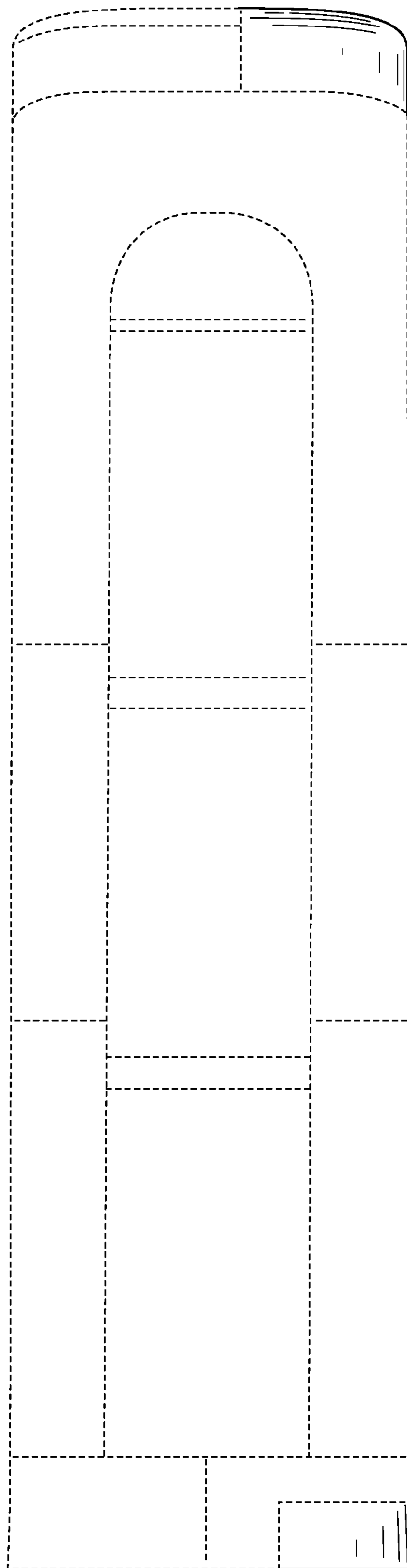
**FIG. 3**



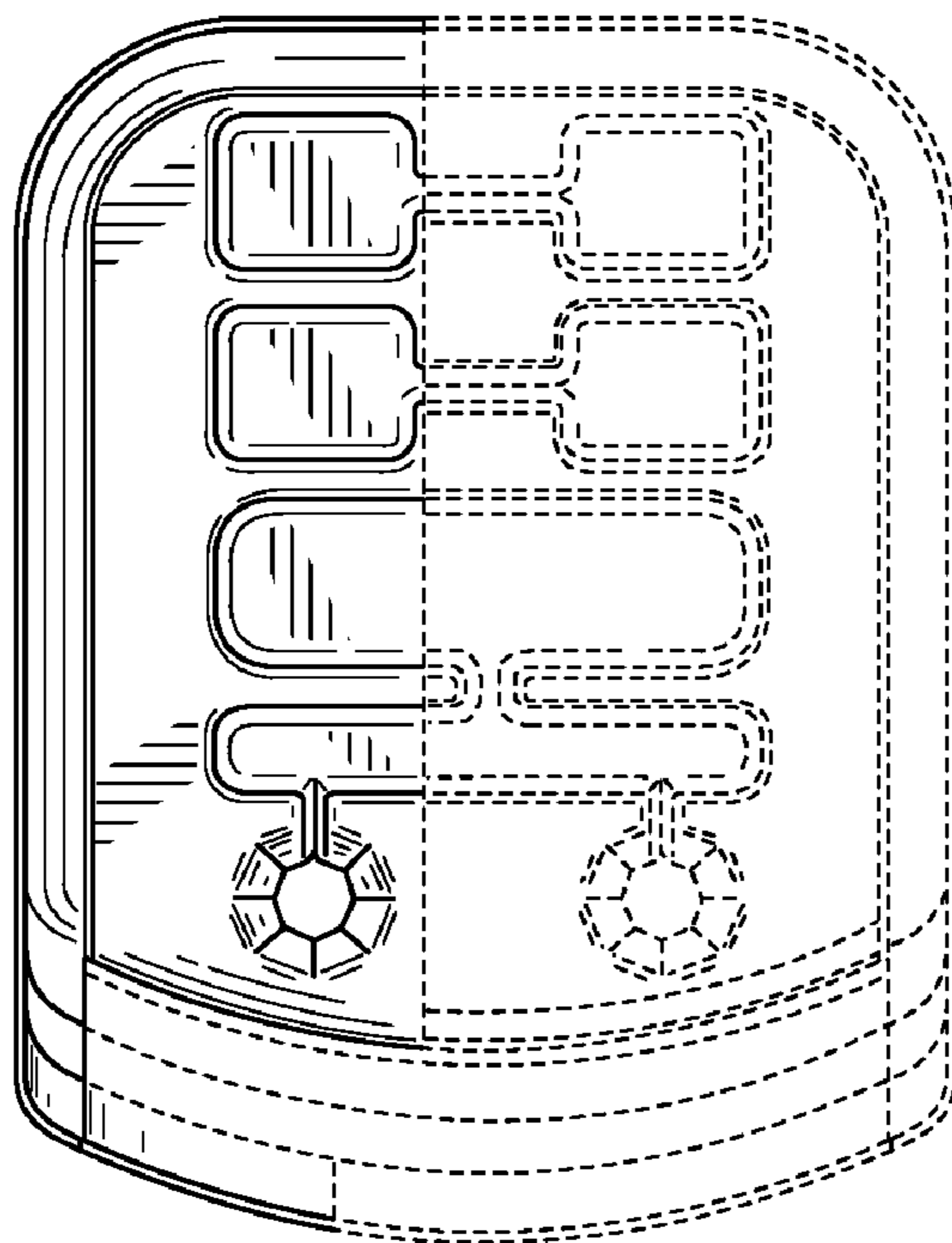
**FIG. 4**

**FIG. 5**

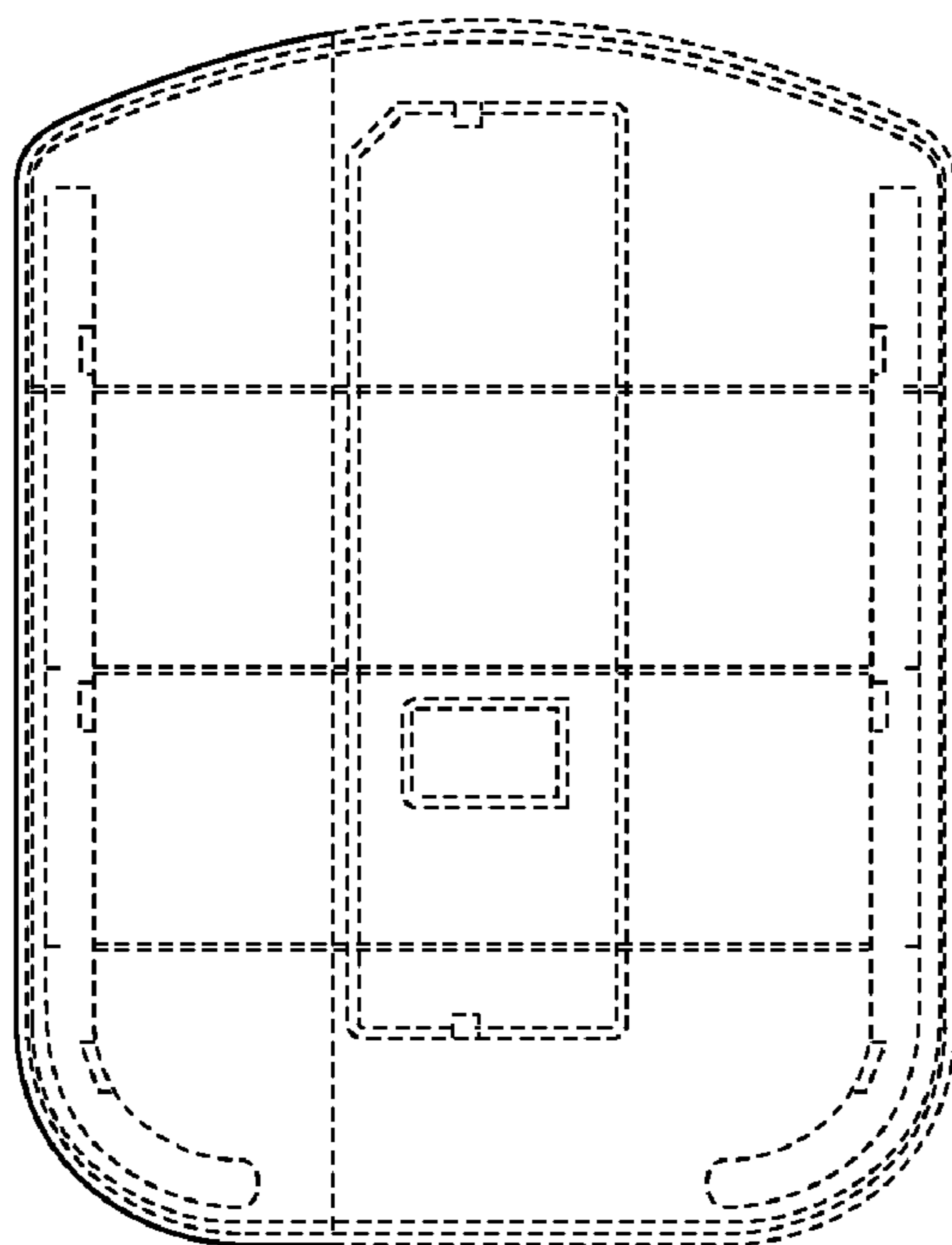




**FIG. 6**



**FIG. 7**



**FIG. 8**