



US00D644047S

(12) **United States Design Patent**  
**Fujii et al.**

(10) **Patent No.:** **US D644,047 S**

(45) **Date of Patent:** **\*\* Aug. 30, 2011**

(54) **SEAM PORTION OF A SEAT FOR A VEHICLE**

(75) Inventors: **Noriaki Fujii**, Chigasaki (JP); **Niki Miyagi**, Kawaguchi (JP); **Akiho Ito**, Yokohama (JP)

(73) Assignee: **Midori Anzen Co., Ltd.** (JP)

(\*\*) Term: **14 Years**

(21) Appl. No.: **29/322,247**

(22) Filed: **Jul. 31, 2008**

(30) **Foreign Application Priority Data**

Jan. 31, 2008 (JP) ..... D2008-002151

(51) **LOC (9) Cl.** ..... **06-01**

(52) **U.S. Cl.** ..... **D6/500; D6/356**

(58) **Field of Classification Search** ..... D6/334-336,  
D6/360-369, 374, 379-380, 498, 500-502;  
264/46.7; 297/232, 353, 354.1, 391, 411.27,  
297/452.13, 452.19, 452.21, 452.24, 452.26,  
297/452.29, 452.32-452.33, 452.34, 452.35,  
297/452.37, 452.48, 452.56, 452.64  
See application file for complete search history.

(56) **References Cited**

**U.S. PATENT DOCUMENTS**

2,491,784 A \* 12/1949 Thompson ..... 297/252  
D288,505 S \* 3/1987 Yamasaki ..... D6/360  
D354,629 S \* 1/1995 Chapman ..... D6/356  
D535,499 S \* 1/2007 True ..... D6/500  
D604,968 S \* 12/2009 True ..... D6/502

D605,879 S \* 12/2009 Krauss et al. .... D6/500  
D615,315 S \* 5/2010 Andersen ..... D6/375  
D626,349 S \* 11/2010 Bashir et al. .... D6/356

**OTHER PUBLICATIONS**

“JIS Classification and Identification Symbol of Seam JIS L 0121”  
Jul. 1, 1984, showing 4.07.02, 5.20.01, and 5.42.01.

“Car and Drive”, Dec. 10, 1999, p. 25, Issue No. 23, published by  
Diamond K.K.

Brochure “Copen”, Jun. 11, 2004, p. 38, published by Daihatsu  
Kogyo K.K.

\* cited by examiner

*Primary Examiner* — Zenia Bennett

(74) *Attorney, Agent, or Firm* — SAIDMAN DesignLaw  
Group

(57) **CLAIM**

The ornamental design for an seam portion of a seat for a  
vehicle, as shown and described.

**DESCRIPTION**

FIG. 1 is a front view of an seam portion of a seat for a vehicle  
showing our new design;

FIG. 2 is a perspective view showing the environment in  
which the ornamental portion disclosed in FIG. 1 is applied  
to, the view being observed from the front angle as in FIG. 1  
but from an upper direction, and it being understood that the  
claimed pattern is repeated at least vertically, as shown sche-  
matically by broken lines; and,

FIG. 3 is a sectional view along line 3-3 of FIG. 1.

The broken lines showing of a seat in FIG. 2 are for illustrative  
purposes only and form no part of the claimed design.

**1 Claim, 3 Drawing Sheets**

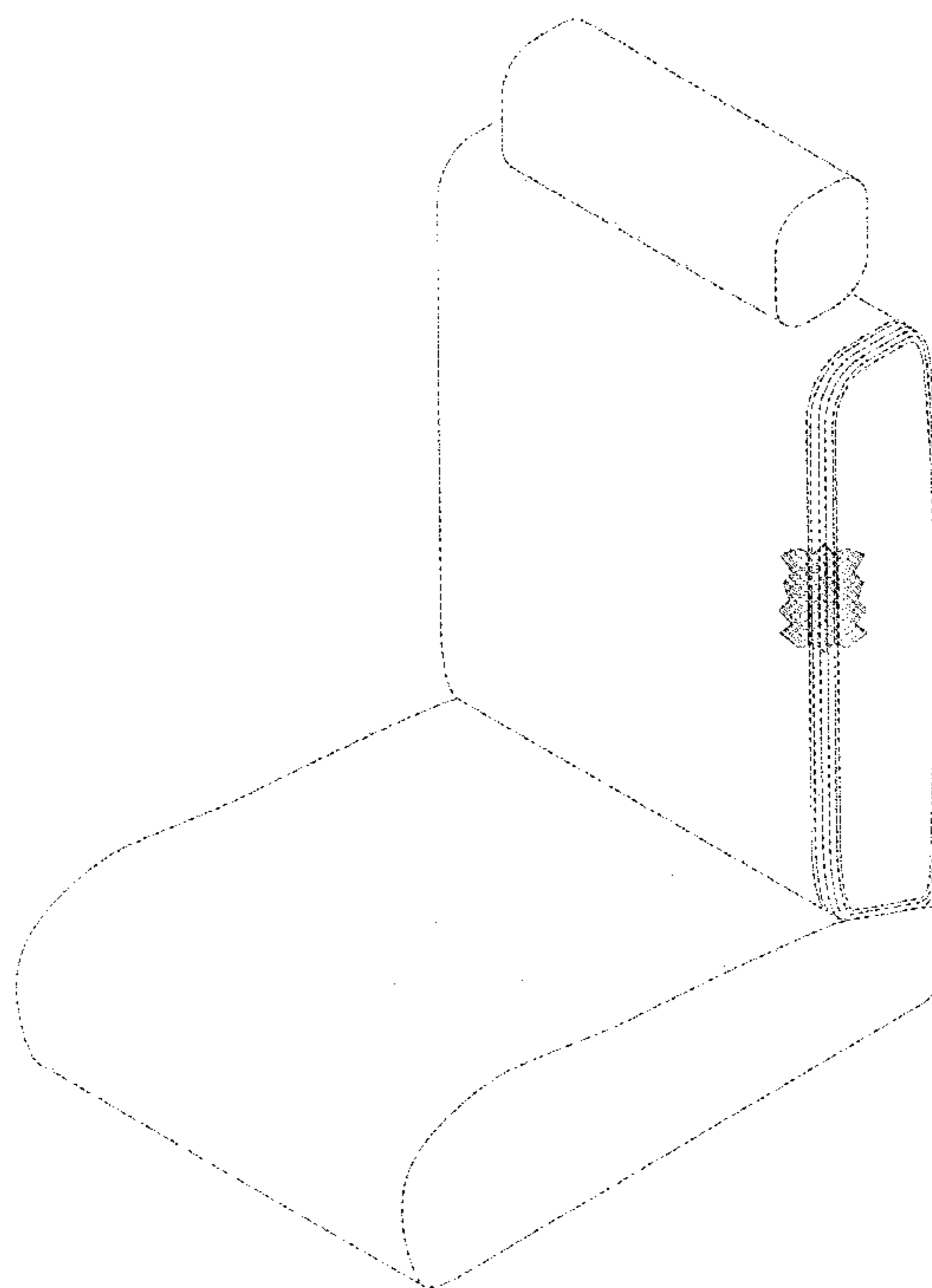
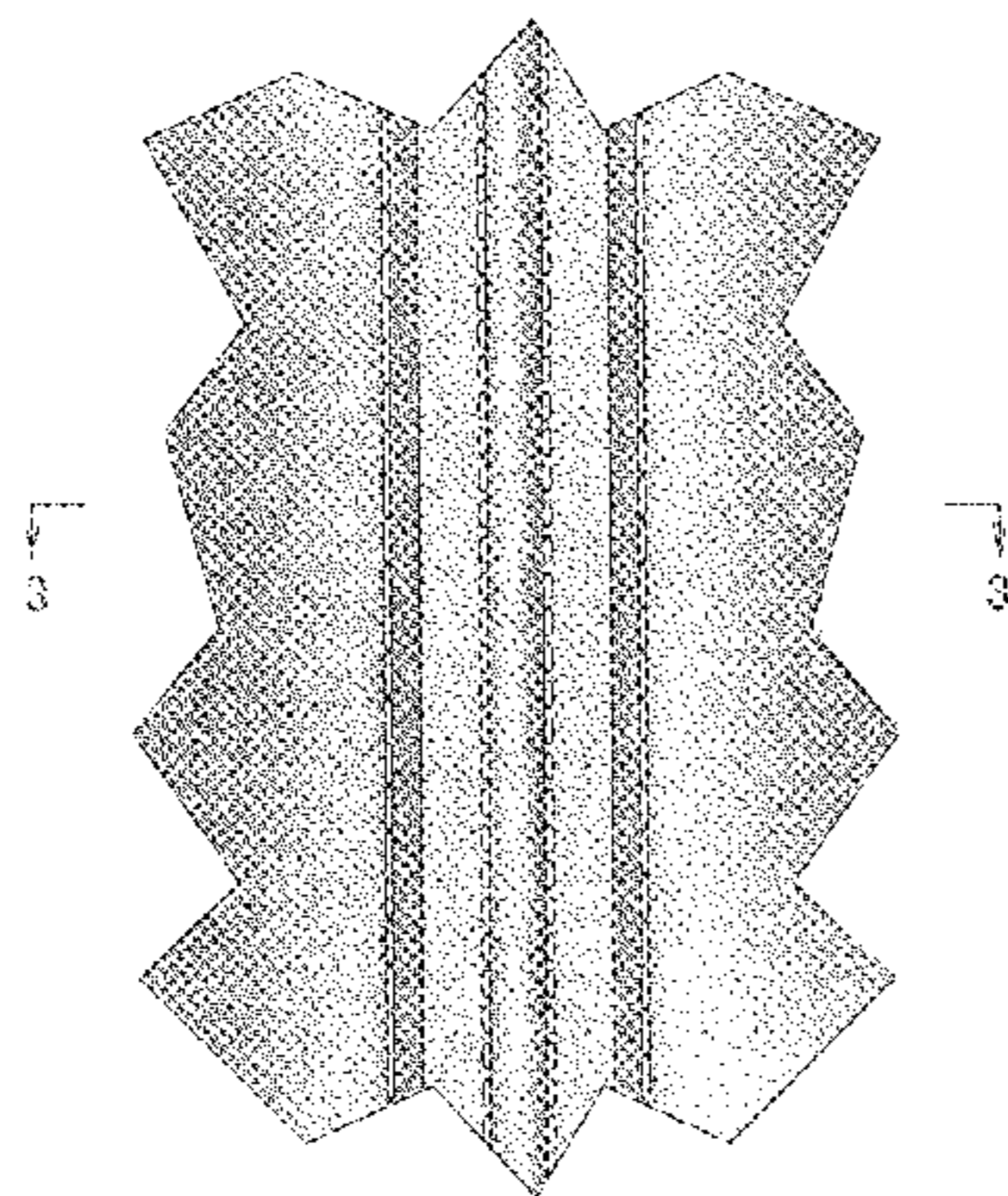



Fig. 1

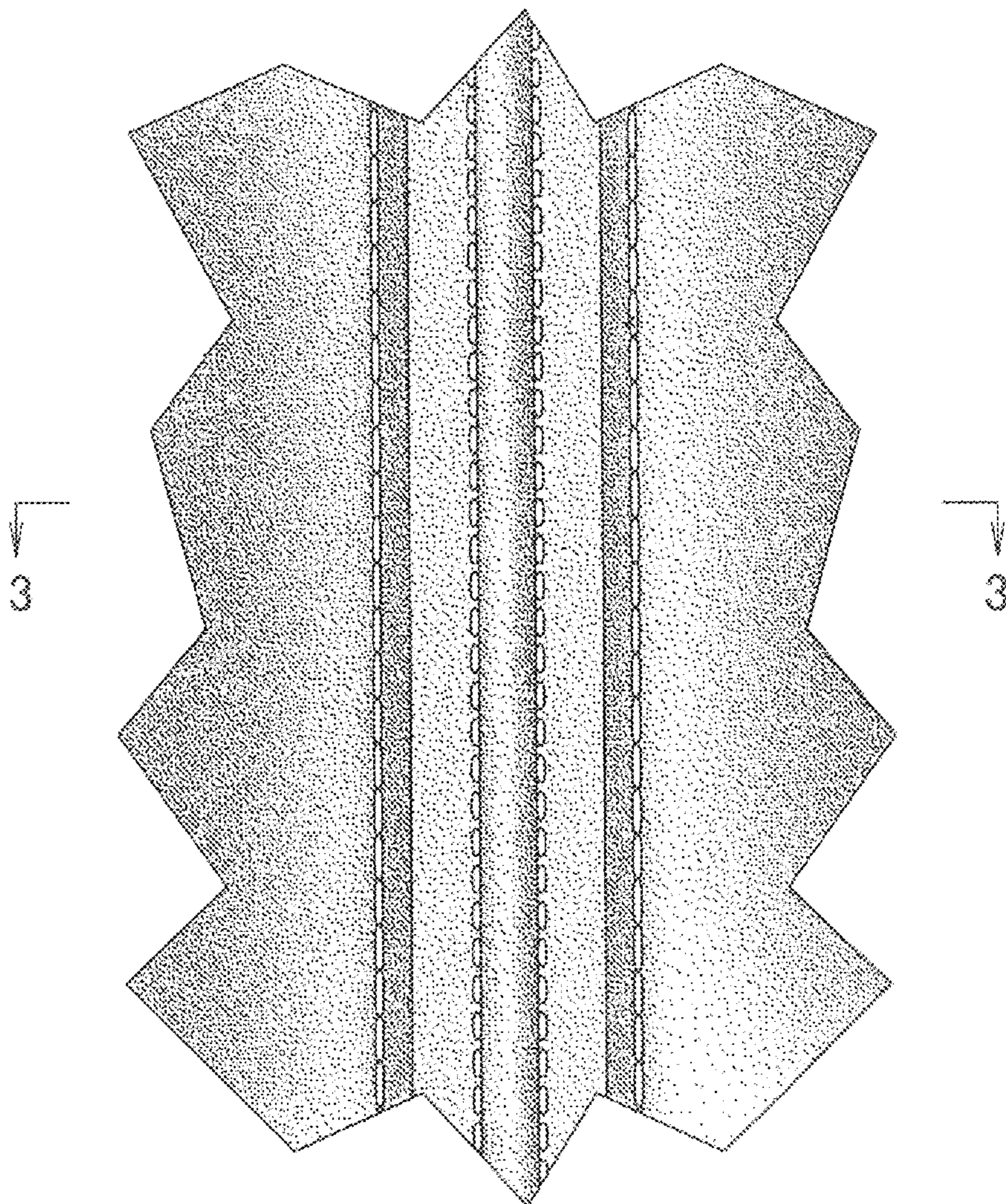

Fig.2

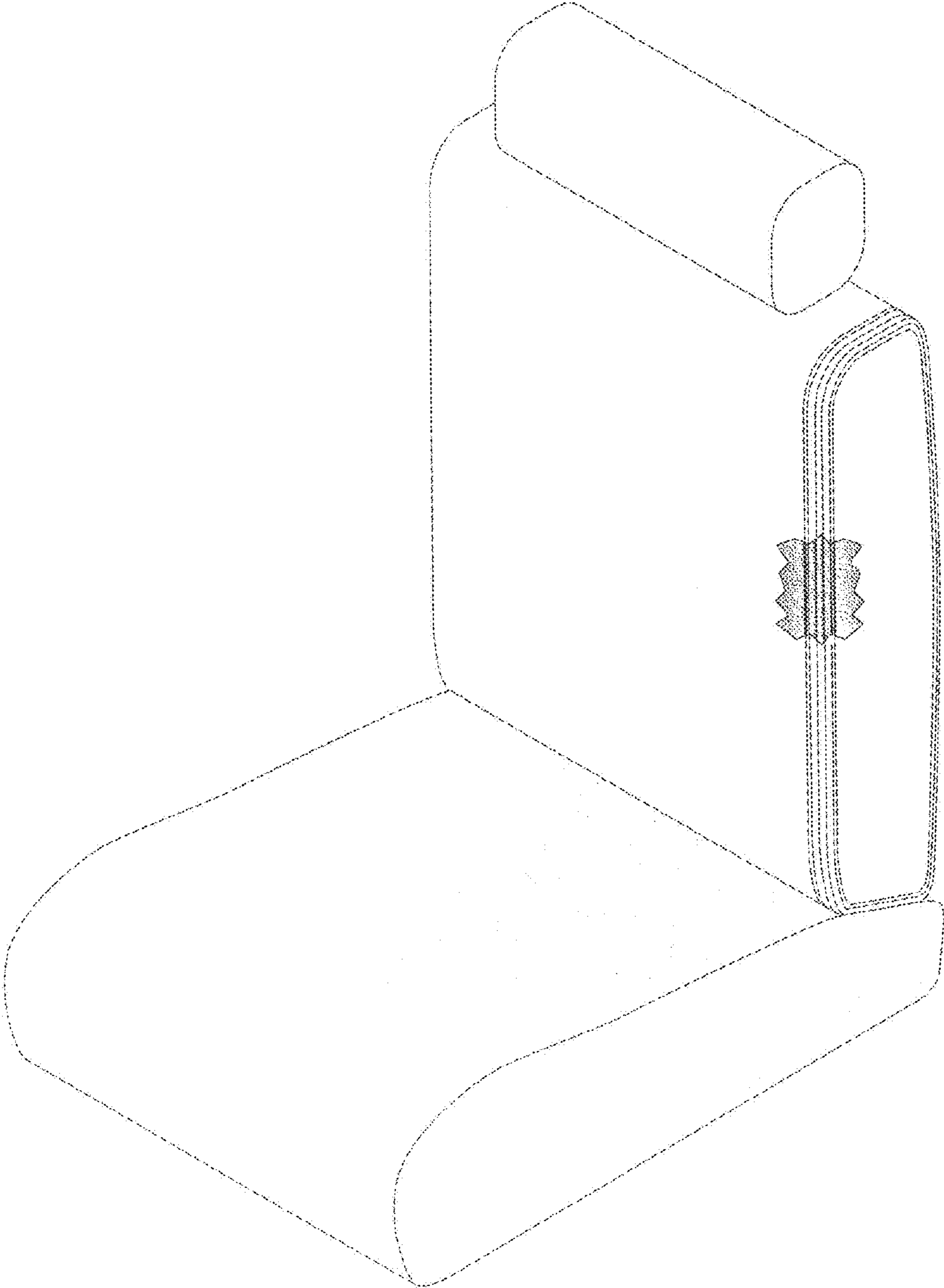

Fig.3

