



US00D643985S

(12) **United States Design Patent**
Dedrick

(10) **Patent No.:** **US D643,985 S**

(45) **Date of Patent:** **** Aug. 23, 2011**

- (54) **DUSTPAN**
- (76) **Inventor:** **Ted Randall Dedrick, Jamul, CA (US)**
- (**) **Term:** **14 Years**
- (21) **Appl. No.:** **29/348,889**
- (22) **Filed:** **Feb. 19, 2010**
- (51) **LOC (9) Cl.** **07-05**
- (52) **U.S. Cl.** **D32/74**
- (58) **Field of Classification Search** D32/74,
D32/41; D30/162; D7/691, 688; D4/116;
15/257.5, 257.3, 257.2; 403/241; 294/1.1,
294/49

See application file for complete search history.

- 3,056,992 A * 10/1962 Clough 15/257.3
- 5,826,297 A * 10/1998 Footer et al. 15/257.2
- D426,353 S * 6/2000 Renforth D30/162
- D462,529 S * 9/2002 Best et al. D4/116
- 6,733,056 B2 * 5/2004 Daniele 294/1.1
- D493,265 S * 7/2004 Libman et al. D32/74
- D509,035 S * 8/2005 Libman et al. D32/74
- 7,047,907 B1 * 5/2006 Johnston 119/867
- D602,214 S * 10/2009 Petersen D30/162
- D602,657 S * 10/2009 Petersen D30/162

* cited by examiner

Primary Examiner — Austin Murphy

(57) **CLAIM**
The ornamental design for a dustpan, as shown.

DESCRIPTION

FIG. 1 is a top perspective view of a dustpan showing my new design;
 FIG. 2 is a left side elevational view thereof;
 FIG. 3 is a front elevational view thereof;
 FIG. 4 is a top plan view thereof;
 FIG. 5 is a rear elevational view thereof;
 FIG. 6 is a right devotional view thereof; and,
 FIG. 7 is a bottom plan view thereof.
 The broken lines shown in FIGS. 2 and 6 represent portions of the dustpan that form no part of the claimed design.

1 Claim, 2 Drawing Sheets

(56) **References Cited**

U.S. PATENT DOCUMENTS

- 100,008 A * 2/1870 Brewer 294/49
- 255,483 A * 3/1882 Blake 294/49
- 416,387 A * 12/1889 Whitbeck 403/241
- 561,917 A * 6/1896 Rothrock 15/257.5
- 621,683 A * 3/1899 Knight 15/257.5
- 626,843 A * 6/1899 Richardson 15/257.5
- 735,360 A * 8/1903 Furrow 15/257.5
- D68,140 S * 9/1925 Greener D32/74
- D103,453 S * 3/1937 Jackson D32/74
- 2,613,977 A * 10/1952 Kellogg 294/1.1
- 2,651,924 A * 9/1953 Lawrence 15/257.1
- D180,303 S * 5/1957 Timmons D32/74

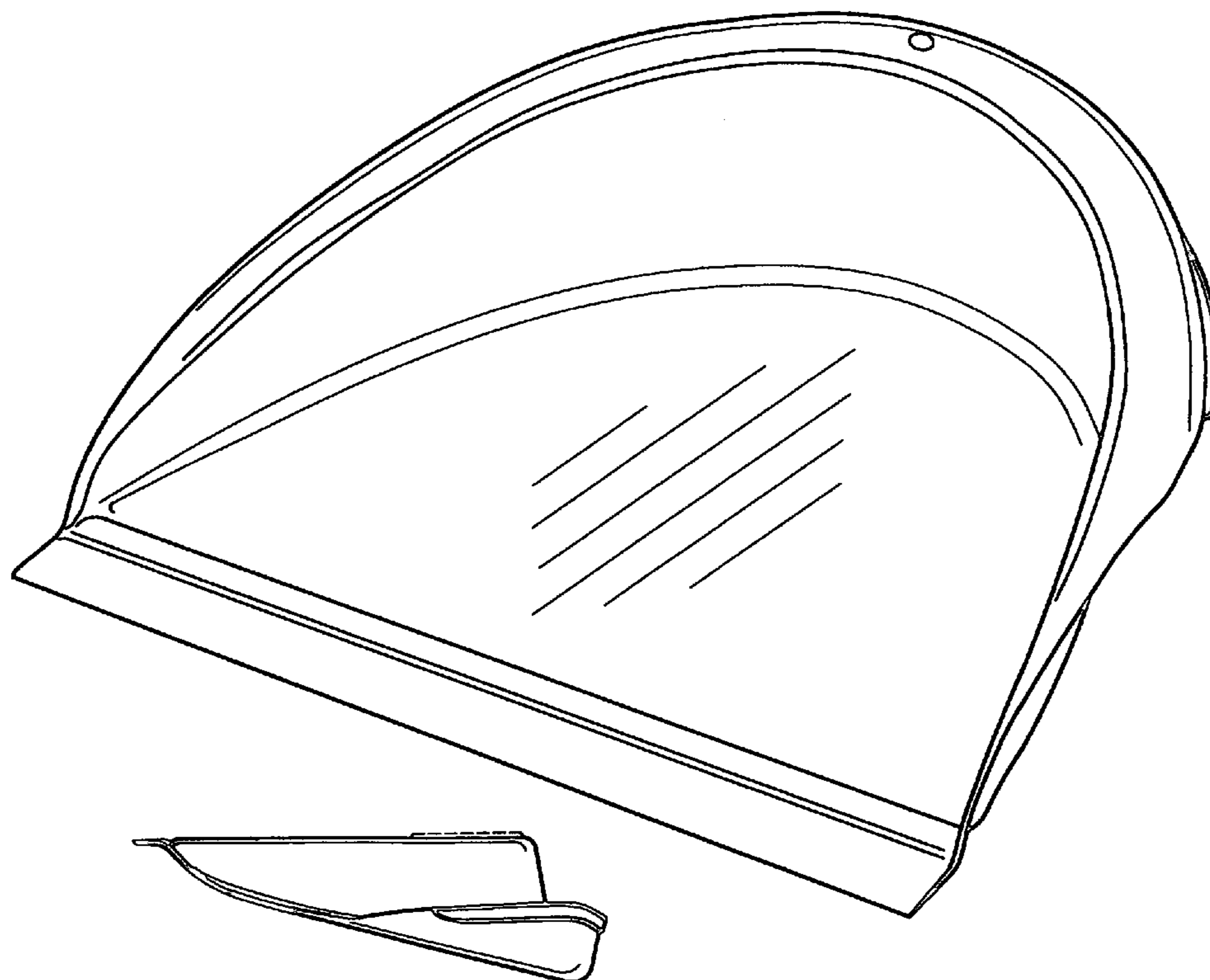

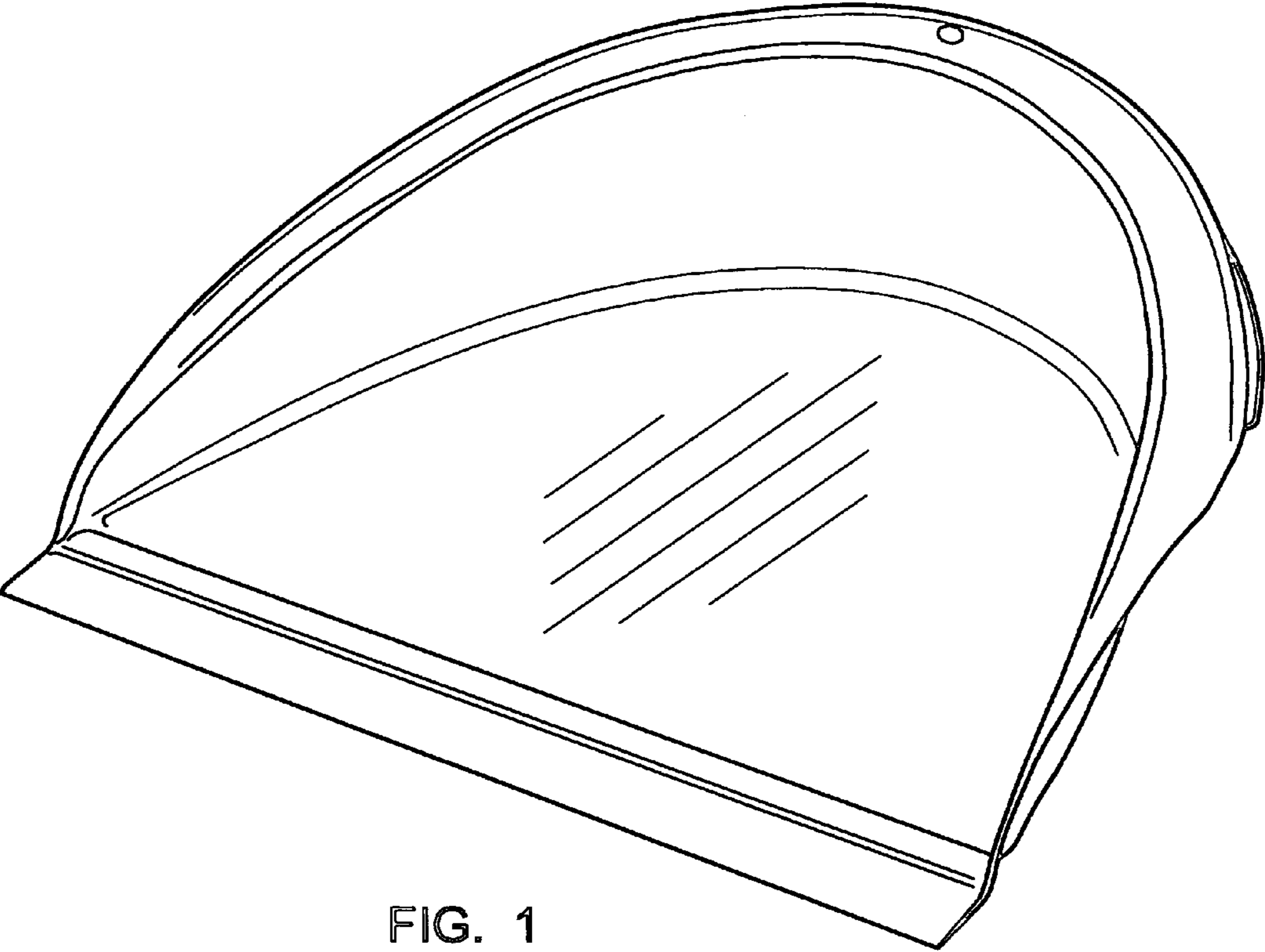

FIG. 1

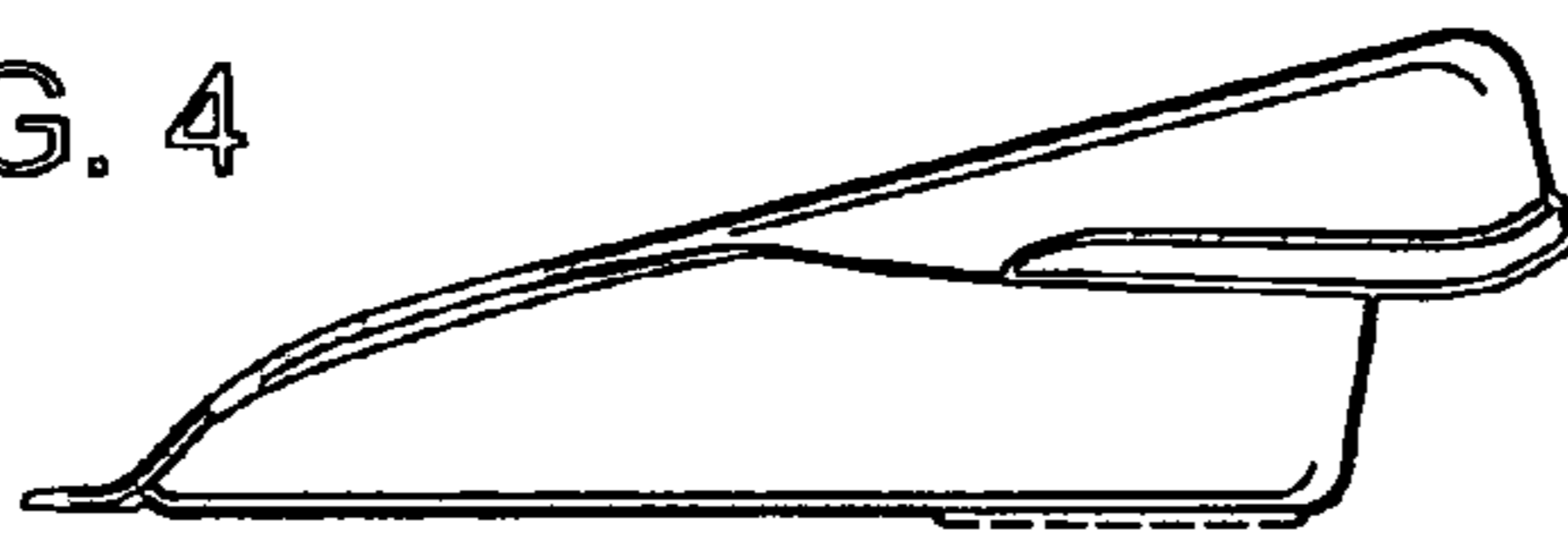
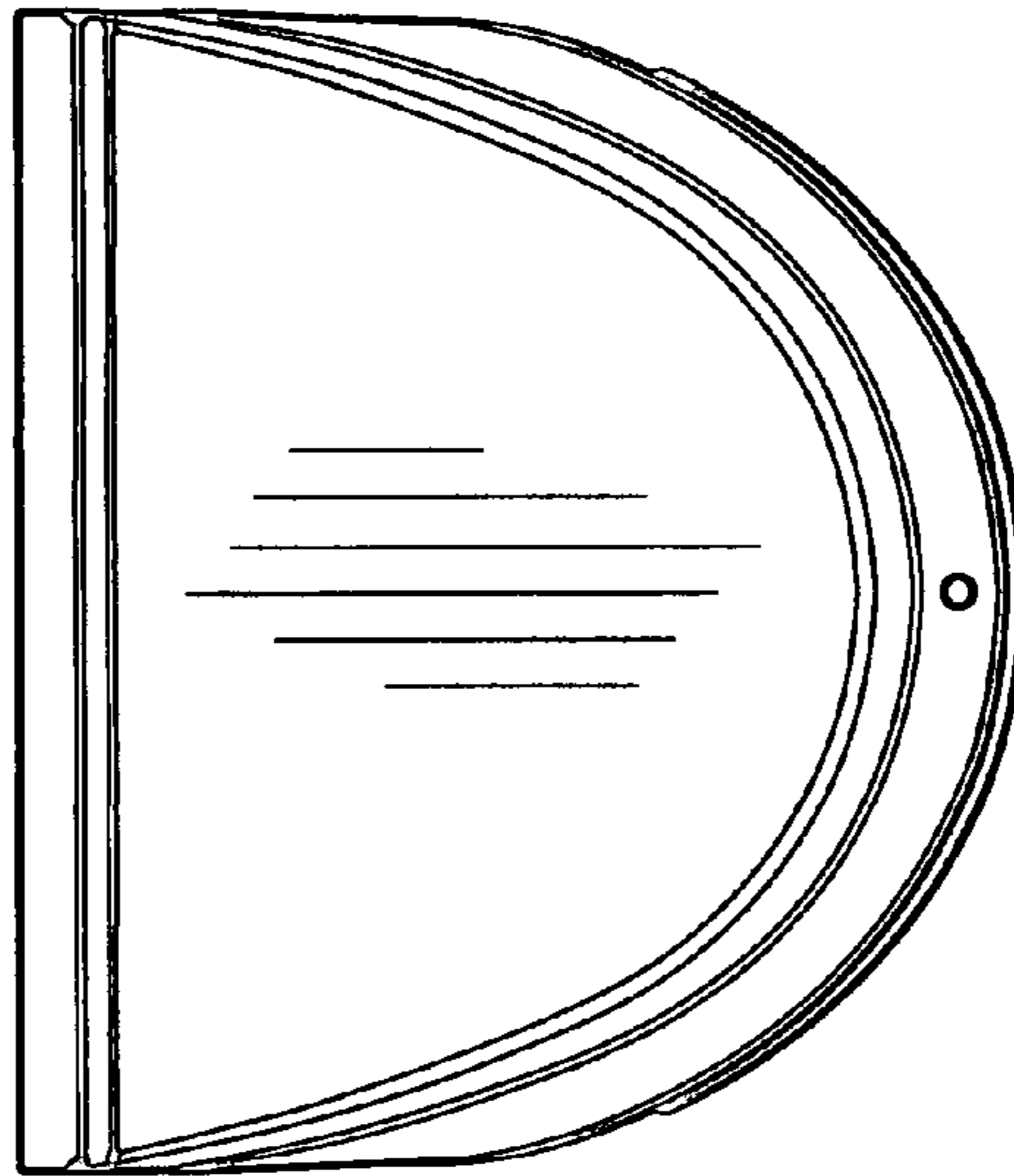
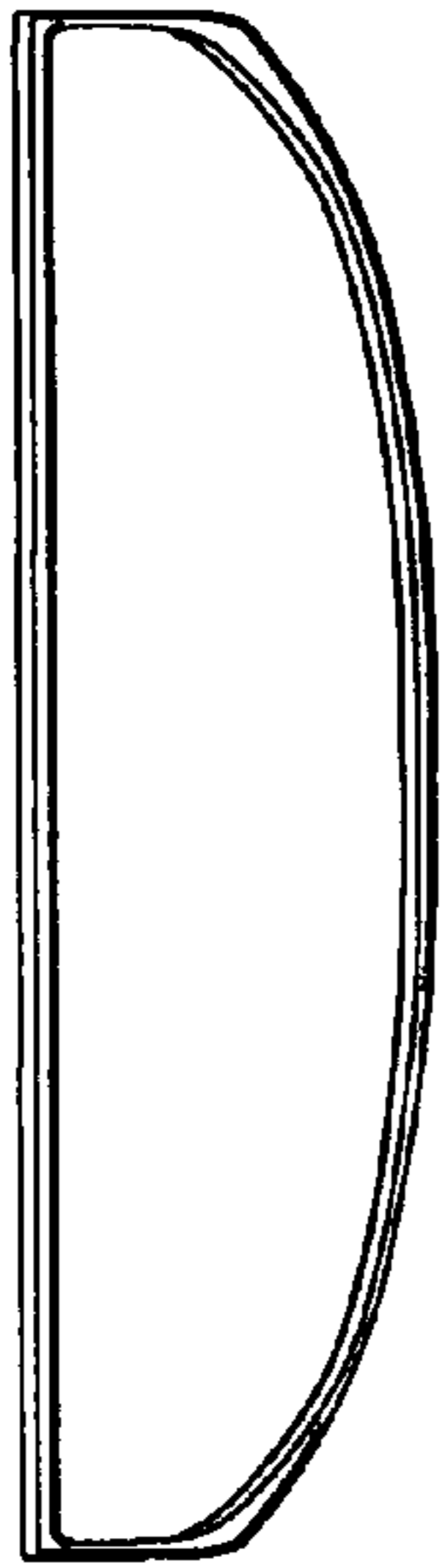
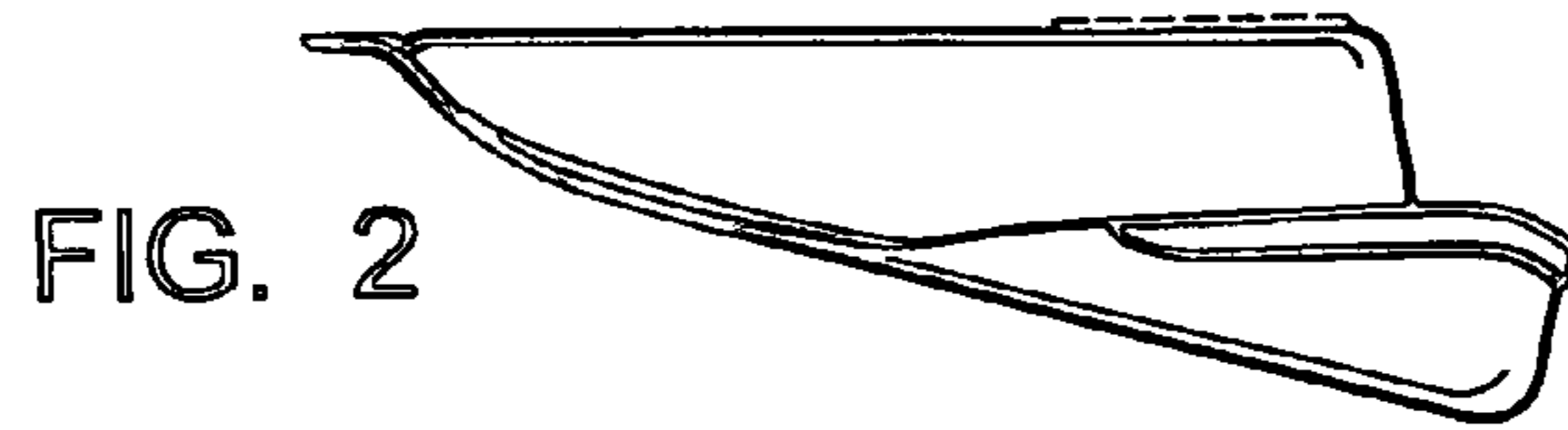

FIG. 6

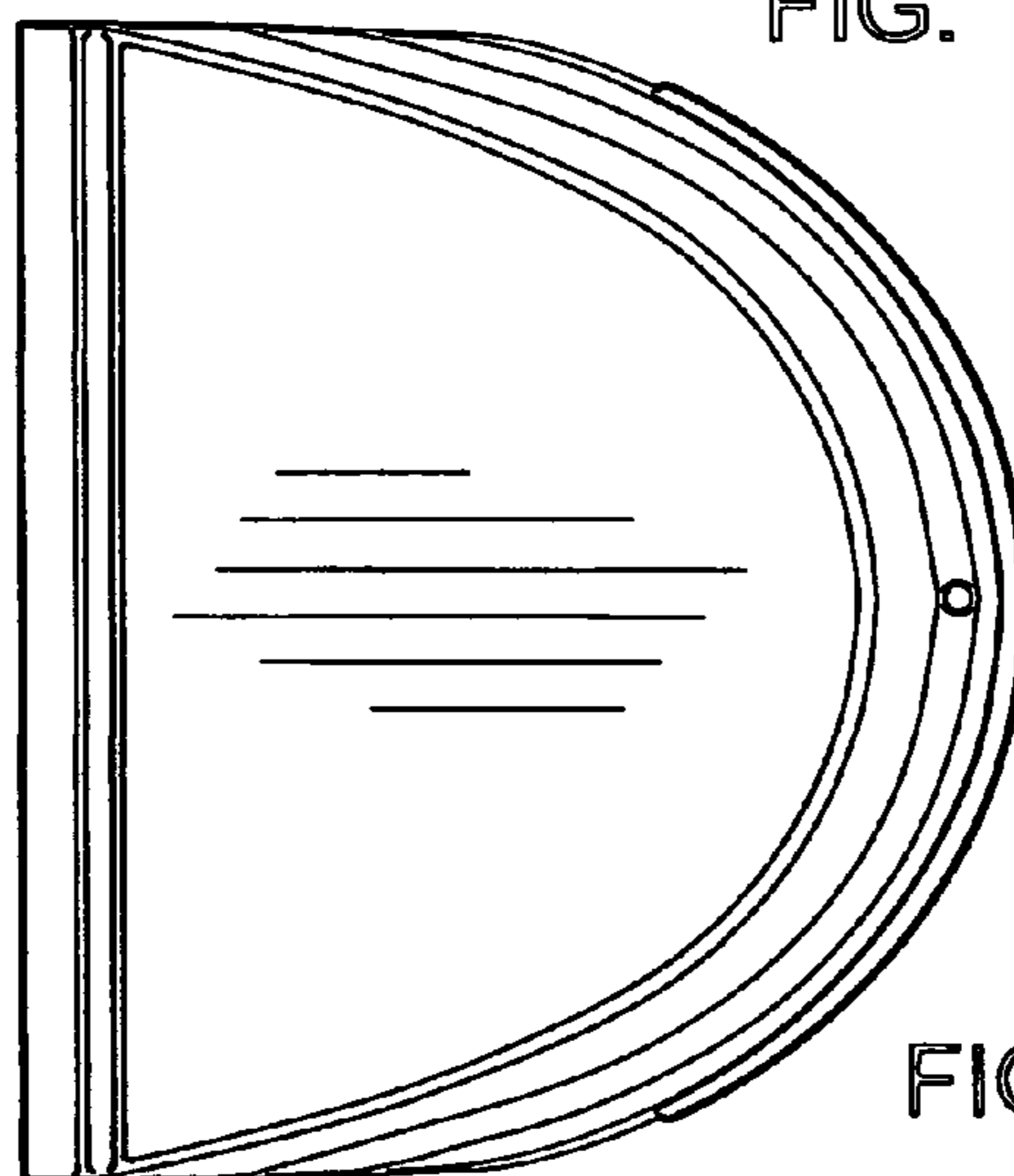

FIG. 7