



US00D643965S

(12) **United States Design Patent**
Sprengers

(10) **Patent No.:** **US D643,965 S**

(45) **Date of Patent:** **** Aug. 23, 2011**

(54) **LUMINAIRE**

(75) Inventor: **David Sprengers**, Antwerp (BE)

(73) Assignee: **Koninklijke Philips Electronics N.V.**,
Eindhoven (NL)

(**) Term: **14 Years**

(21) Appl. No.: **29/376,519**

(22) Filed: **Oct. 8, 2010**

(30) **Foreign Application Priority Data**

Apr. 8, 2010 (EM) 001691957-0001

(51) **LOC (9) Cl.** **26-03**

(52) **U.S. Cl.** **D26/85**

(58) **Field of Classification Search** D26/72,
D26/85, 88, 89, 119, 128; 362/147, 350,
362/404-408, 453-456, 431, 432

See application file for complete search history.

(56) **References Cited**

U.S. PATENT DOCUMENTS

D158,917 S * 6/1950 Wince D26/85
3,038,062 A * 6/1962 Liberman 362/229
D248,184 S * 6/1978 Roberts D26/85
D443,377 S * 6/2001 Handsaker D26/72
D584,847 S * 1/2009 Gaskins D26/85

D590,088 S * 4/2009 Dworschak D26/85
D595,448 S * 6/2009 Sabernig D26/88
D626,272 S * 10/2010 Verelst D26/85

OTHER PUBLICATIONS

Forecast Midnight Hour Collection ceiling light from eurostylelighting.com visited Aug. 15, 2010.*

“Alpine”, “Beam” and “Taos Square” light fixtures from Edge Lighting PDF created Feb. 26, 2009. (3 pages).*

Eurofase Fundamentals “Multiple” Recess Lighting pp. 78-81 of the Eurofase Fundamentals Catalog vol. 20, © 2009. (2 pages).*

Square wall mount lights 19207, 19208, 19209 and 19210 shown on pp. 124 and 125 of the Eurofase Fundamentals Catalog vol. 20, © 2009. (2 pages).*

* cited by examiner

Primary Examiner — Clare E Heflin

(57) **CLAIM**

The ornamental design for a luminaire, as shown.

DESCRIPTION

FIG. 1 is a perspective view showing my design;
FIG. 2 is a front elevational view thereof;
FIG. 3 is a rear elevational view thereof;
FIG. 4 is a right side elevational view thereof;
FIG. 5 is a left side elevational view thereof;
FIG. 6 is a top plan view thereof; and,
FIG. 7 is a bottom plan view thereof.

1 Claim, 4 Drawing Sheets

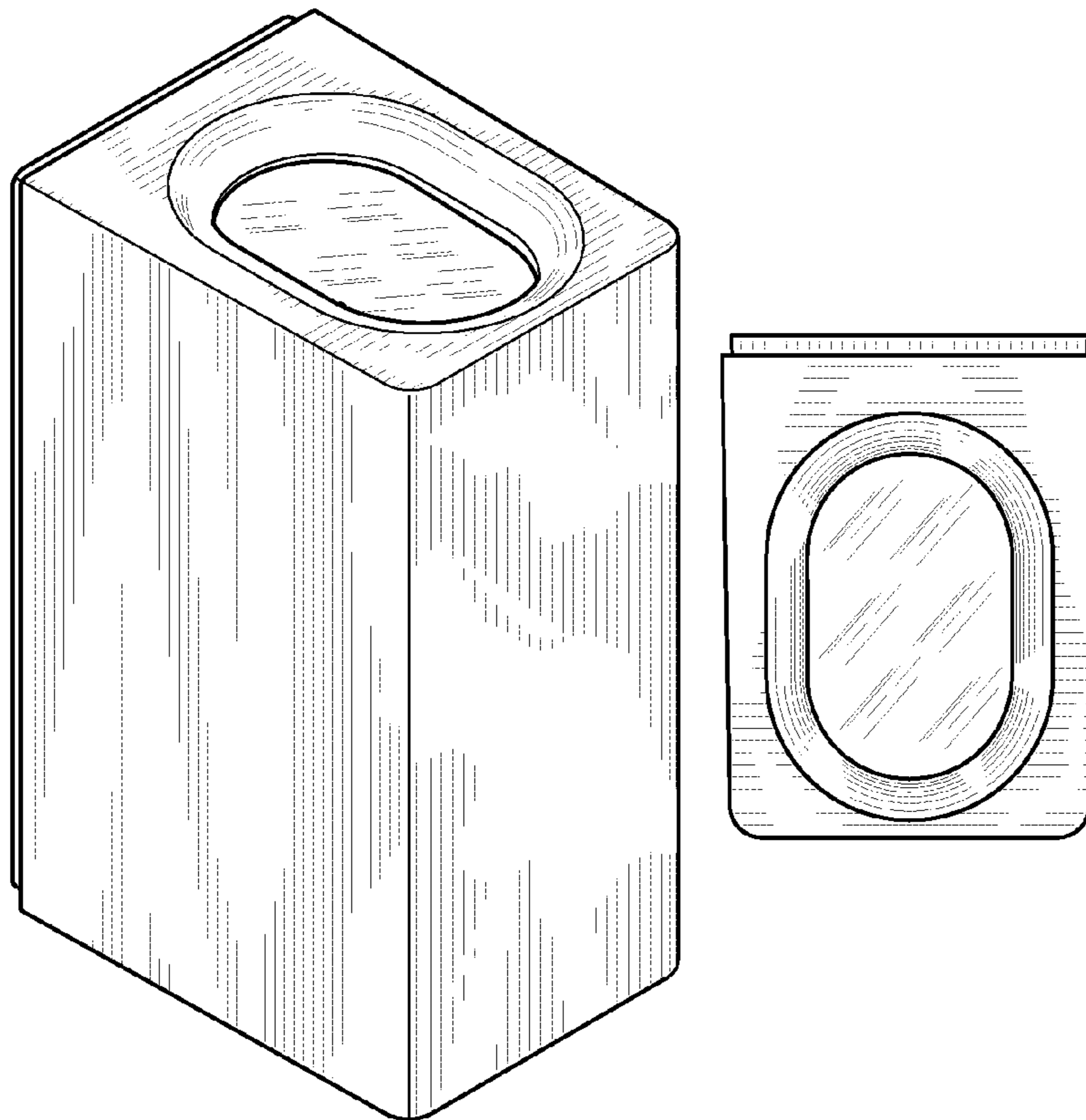



FIG. 1

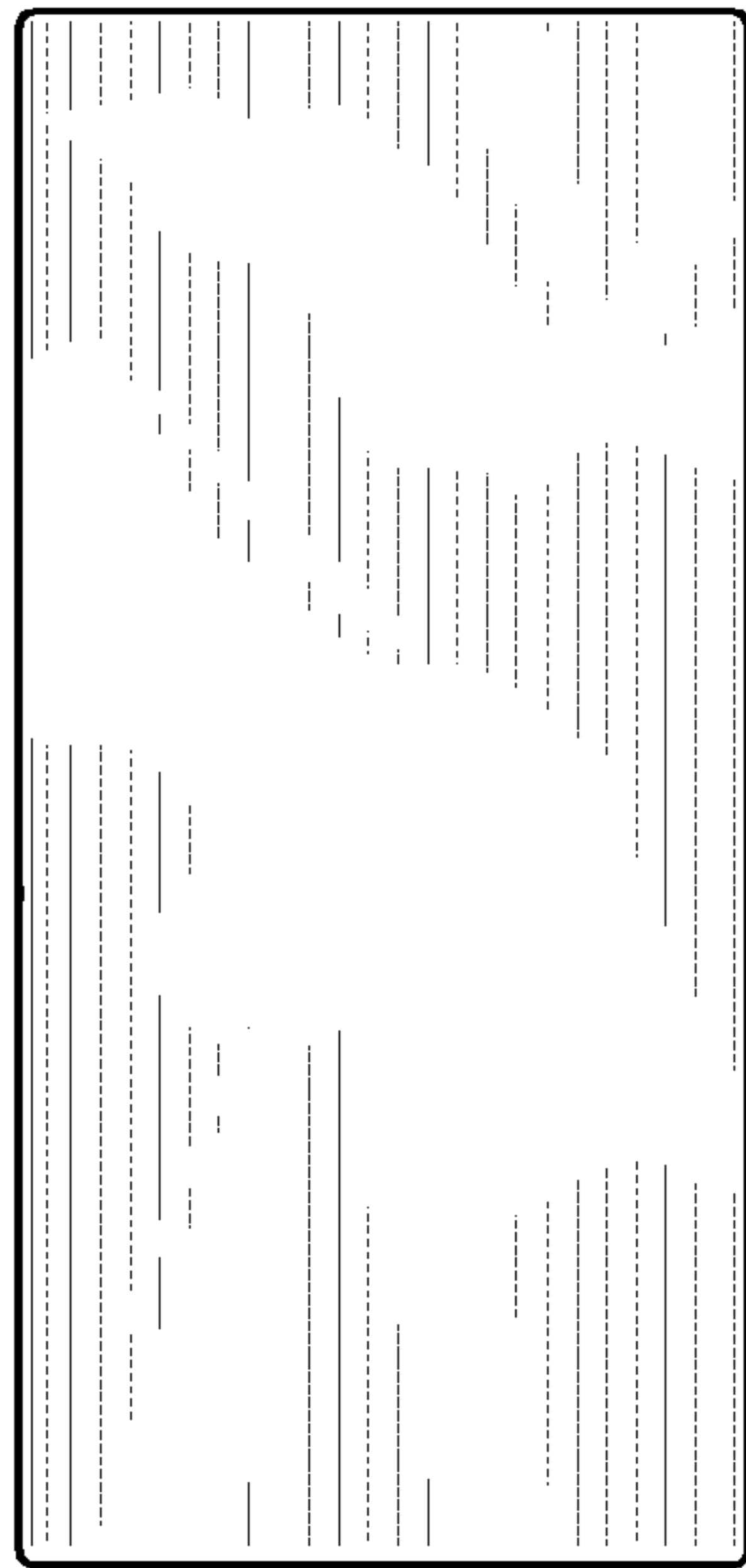

FIG. 2

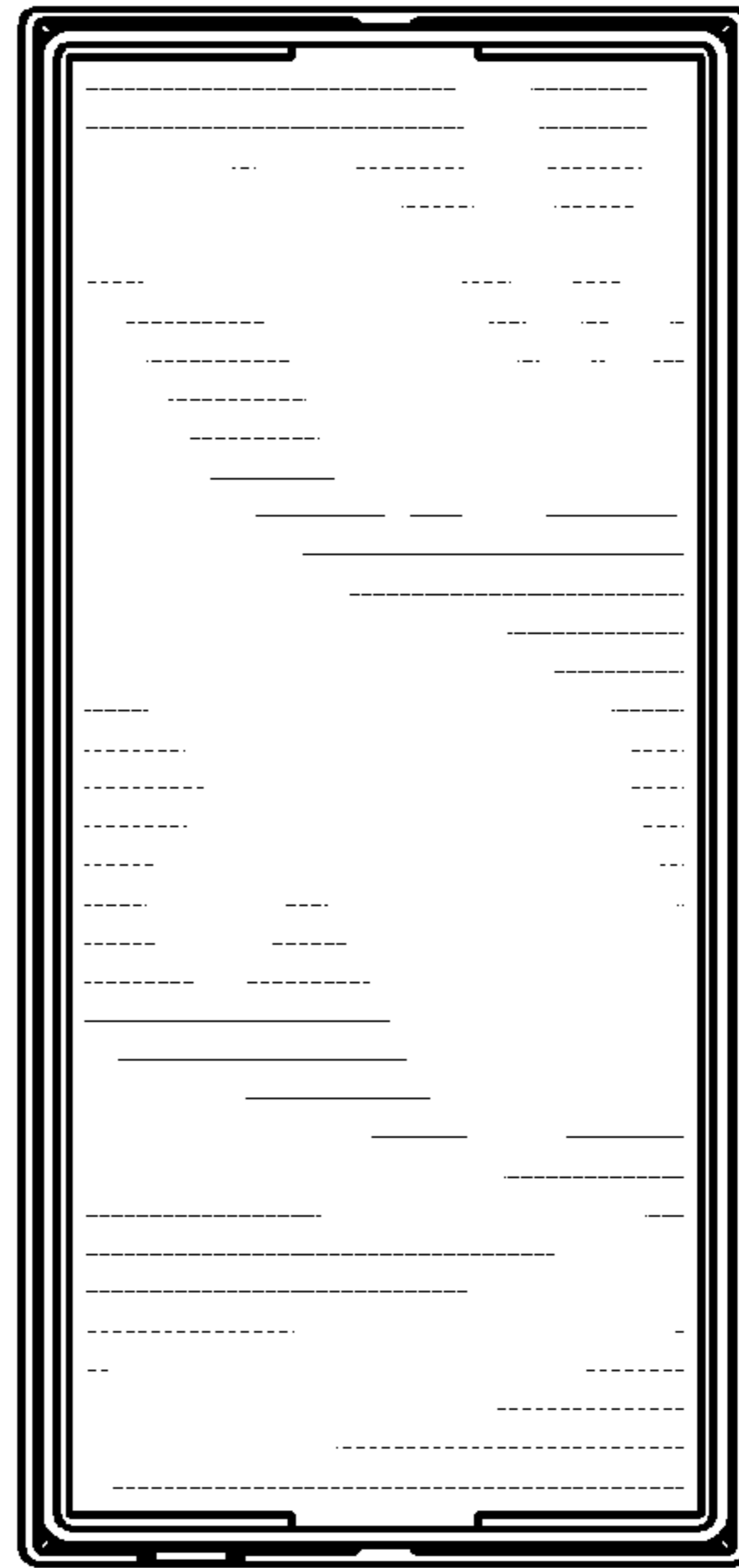

FIG. 3

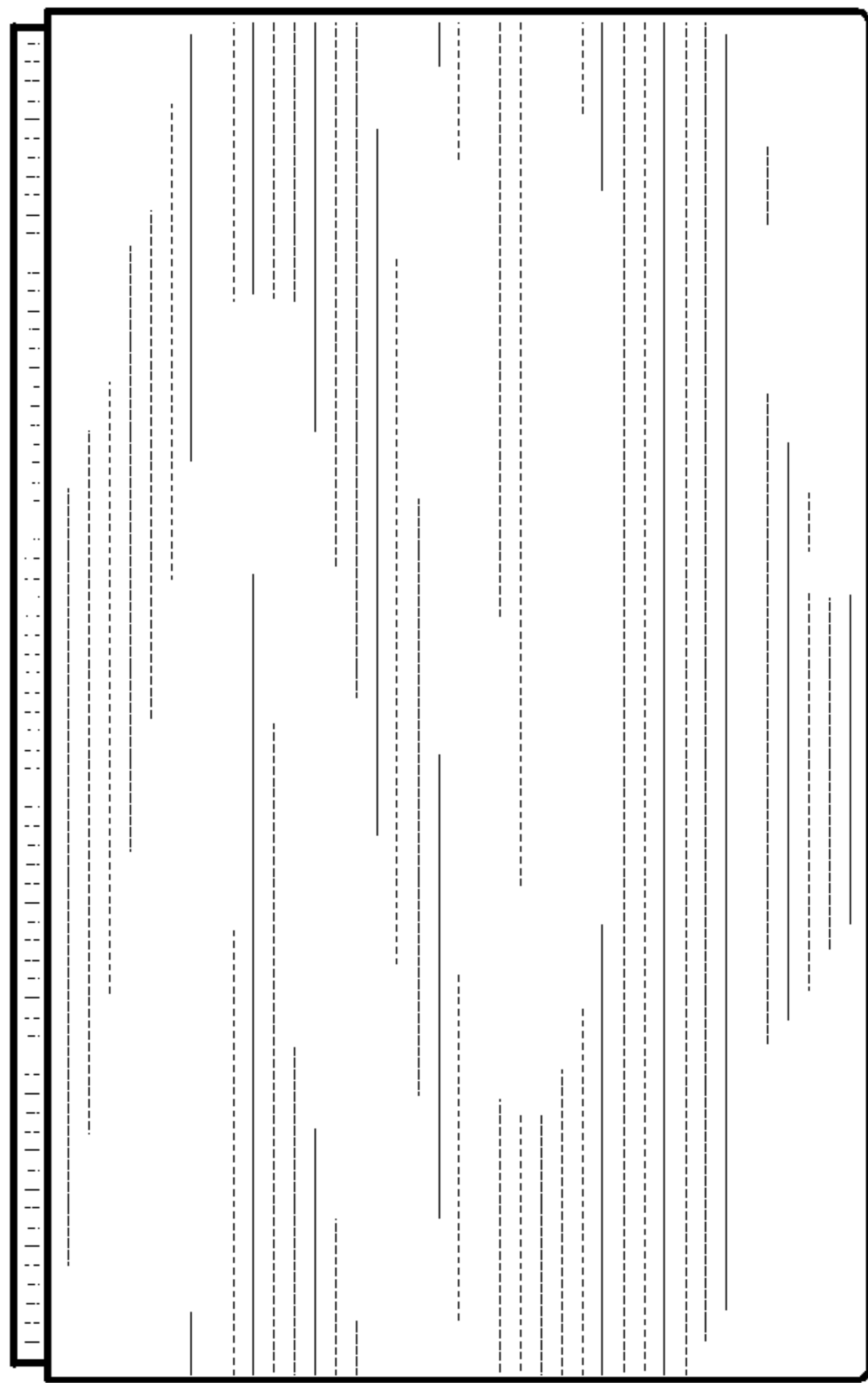

FIG. 4

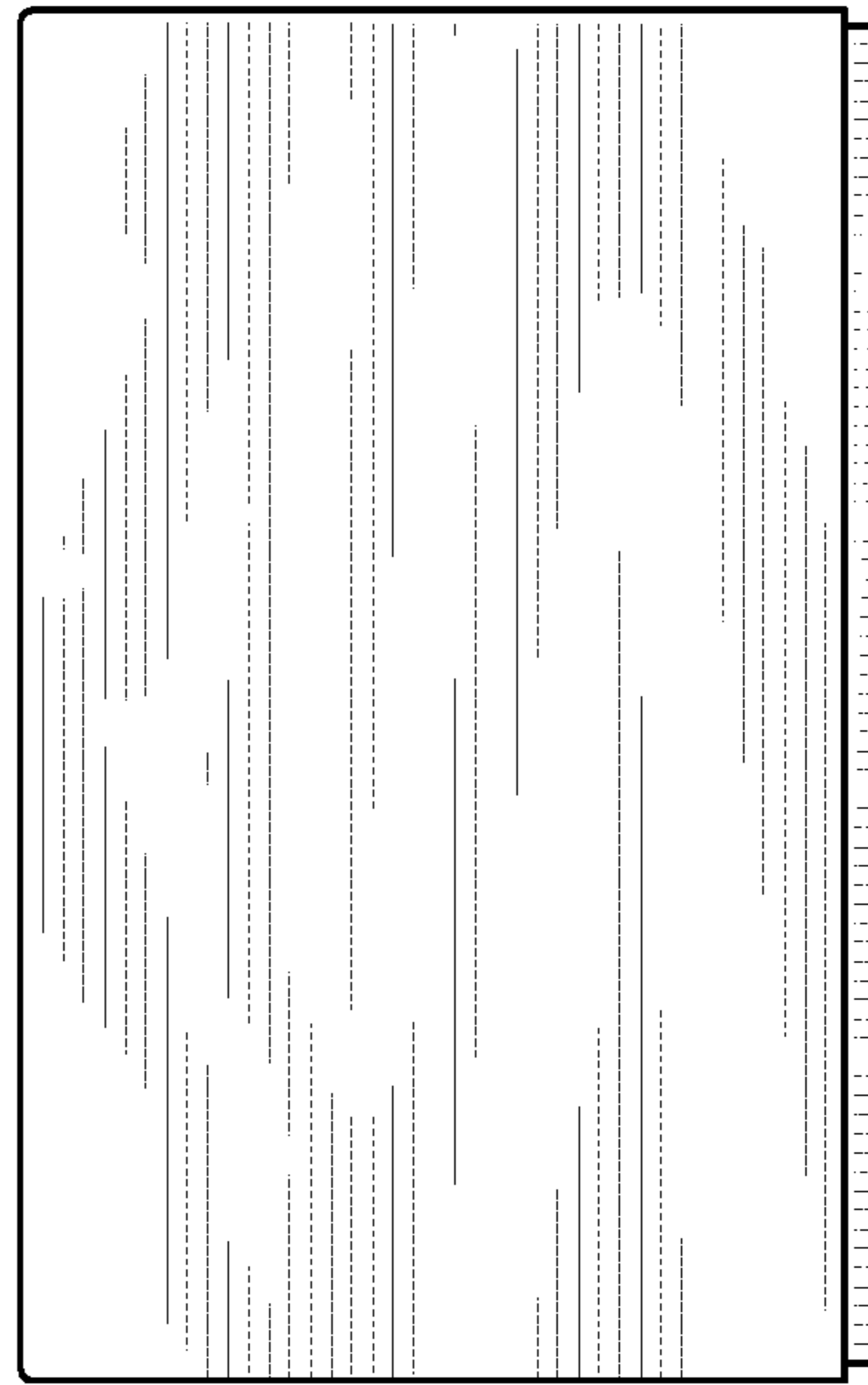

FIG. 5

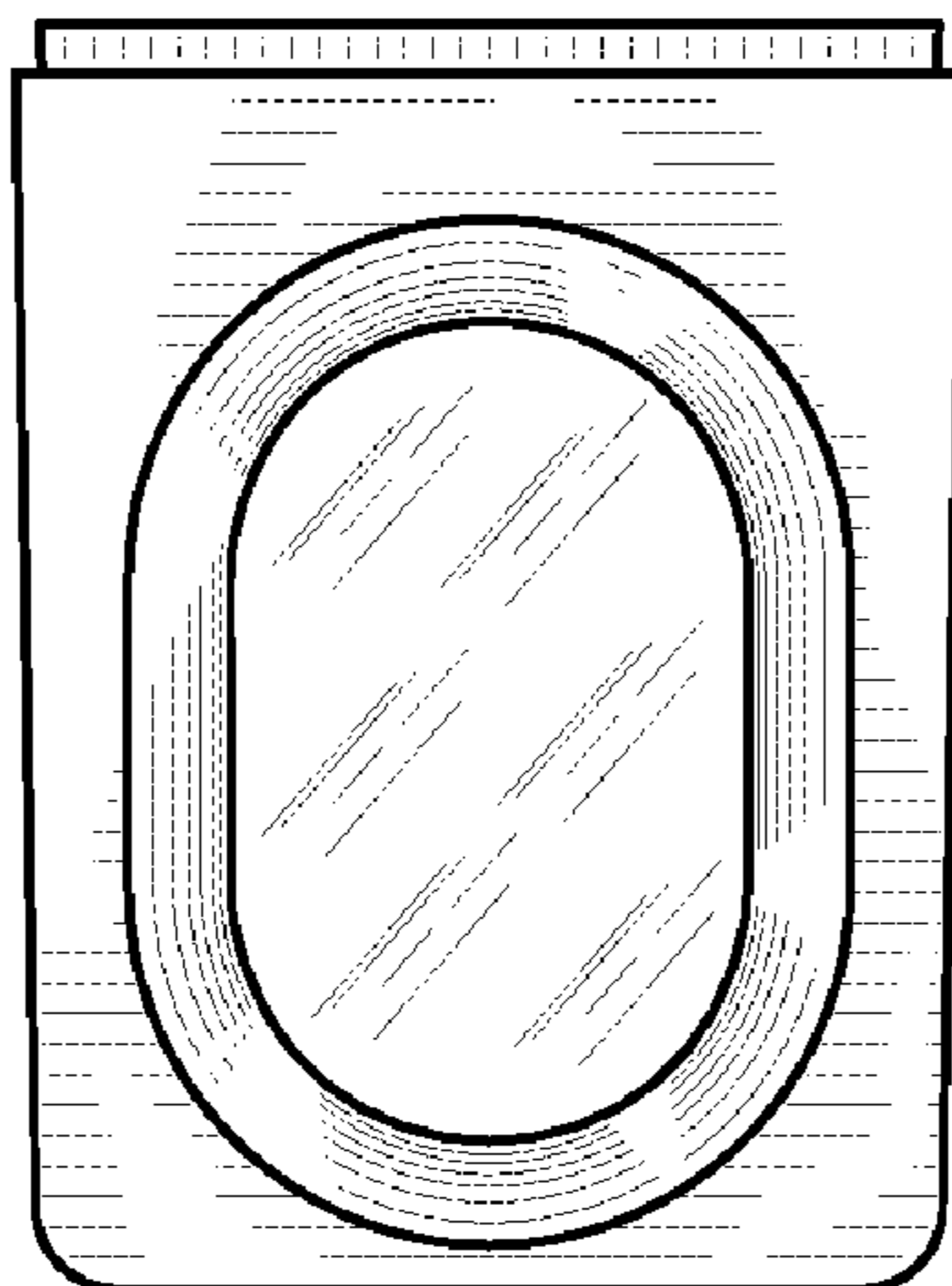

FIG. 6

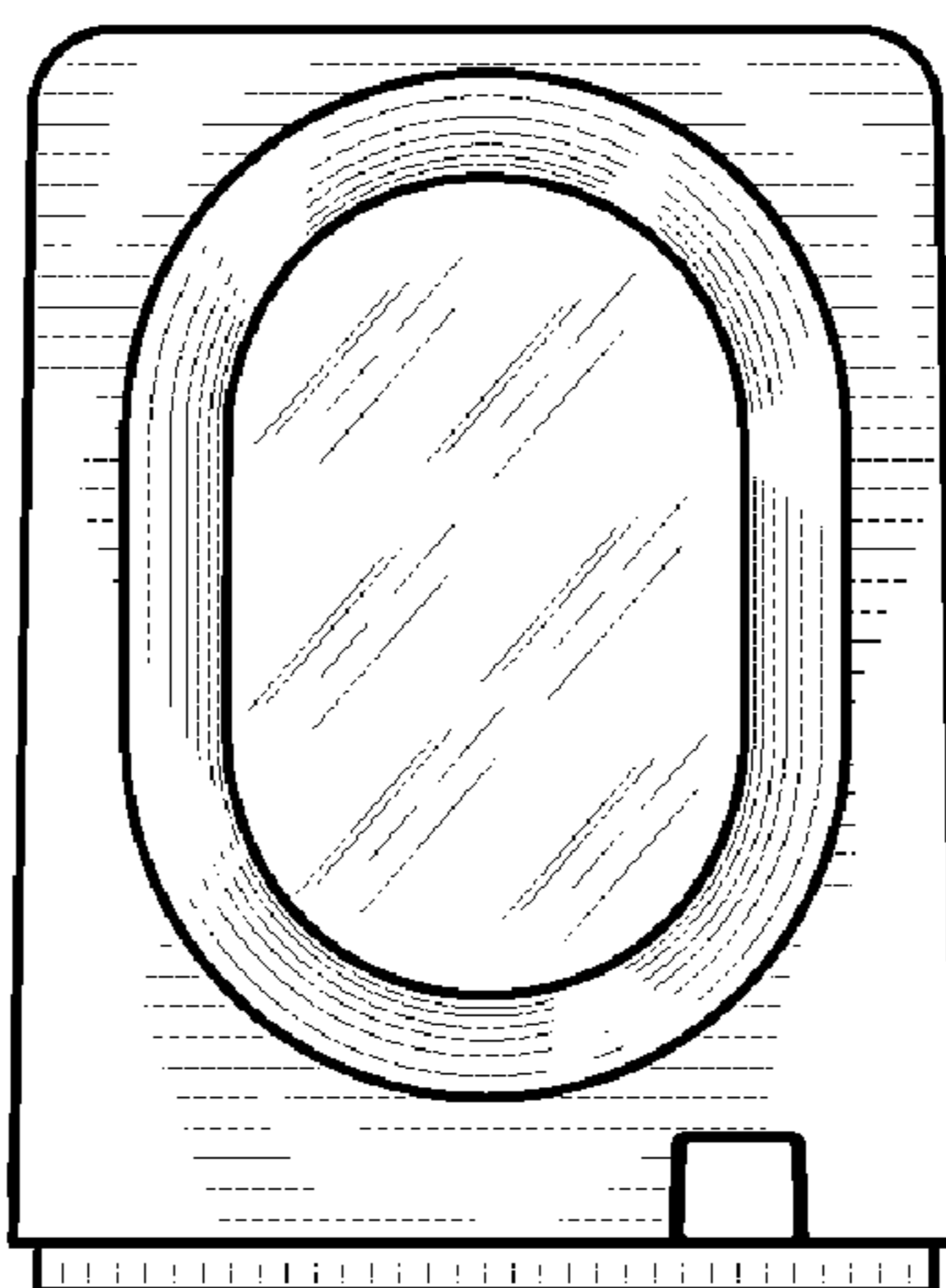

FIG. 7