

US00D643798S

(12) **United States Design Patent**
Gruner

(10) **Patent No.:** **US D643,798 S**

(45) **Date of Patent:** **** Aug. 23, 2011**

(54) **AUTOMOBILE ROOFTOP CARGO BOX**

(75) Inventor: **Frank Gruner**, Gaimersheim (DE)

(73) Assignee: **Thule Sweden AB** (SE)

(**) Term: **14 Years**

(21) Appl. No.: **29/385,905**

(22) Filed: **Feb. 22, 2011**

D462,312 S *	9/2002	Klein	D12/413
D489,674 S *	5/2004	Settelmayer et al.	D12/413
D491,705 S *	6/2004	Mishan et al.	D32/35
D519,914 S *	5/2006	Klein	D12/413
D527,337 S *	8/2006	Klein	D12/413
D543,929 S *	6/2007	D'Andrea et al.	D12/413
D575,723 S *	8/2008	Gruner	D12/413
D595,215 S *	6/2009	Rasche	D12/413
D630,157 S *	1/2011	Farber	D12/413
2010/0006469 A1 *	1/2010	Allouche	206/523
2010/0147712 A1 *	6/2010	Filho et al.	206/315.1
2010/0219089 A1 *	9/2010	Samios	206/315.1

* cited by examiner

Related U.S. Application Data

(62) Division of application No. 29/379,276, filed on Nov. 17, 2010.

Primary Examiner — Caron D Veynar

Assistant Examiner — Katrina Kile

(74) *Attorney, Agent, or Firm* — Novak Druce + Quigg LLP

(30) **Foreign Application Priority Data**

Aug. 31, 2010 (EM) 001232300-0001

Aug. 31, 2010 (EM) 001232300-0002

(51) **LOC (9) Cl.** **12-16**

(52) **U.S. Cl.** **D12/413**

(58) **Field of Classification Search** D12/413,
D12/414, 406, 412, 414.4; 293/37.1, 3, 100;
224/309-310, 315-416, 323-329, 400; D6/552,
D6/317-319, 513-514; D3/304-306; 280/760-762,
280/848, 727, 769; 296/99.1, 37.1, 100.02,
296/157; 206/213, 8, 9, 279, 290, 713, 335,
206/315.1-315.4; D32/35, 58

See application file for complete search history.

(56) **References Cited**

U.S. PATENT DOCUMENTS

D297,631 S * 9/1988 Breger D12/413

D406,558 S * 3/1999 Pendergraph D12/413

D412,881 S * 8/1999 Behringer D12/413

(57) **CLAIM**

I claim the ornamental design for automobile rooftop cargo box, as shown and described.

DESCRIPTION

FIG. 1 is a perspective view of an automobile rooftop cargo box;

FIG. 2 is a front elevational view thereof;

FIG. 3 is a rear elevational view thereof;

FIG. 4 is a right side elevational view thereof;

FIG. 5 is a left side elevational view thereof;

FIG. 6 is a top plan view thereof;

FIG. 7 is a bottom plan view thereof; and,

FIG. 8 is a bottom perspective view thereof.

In the drawings, the broken lines in FIGS. 7 and 8 depict portions of the design that form no part of the claim.

1 Claim, 6 Drawing Sheets

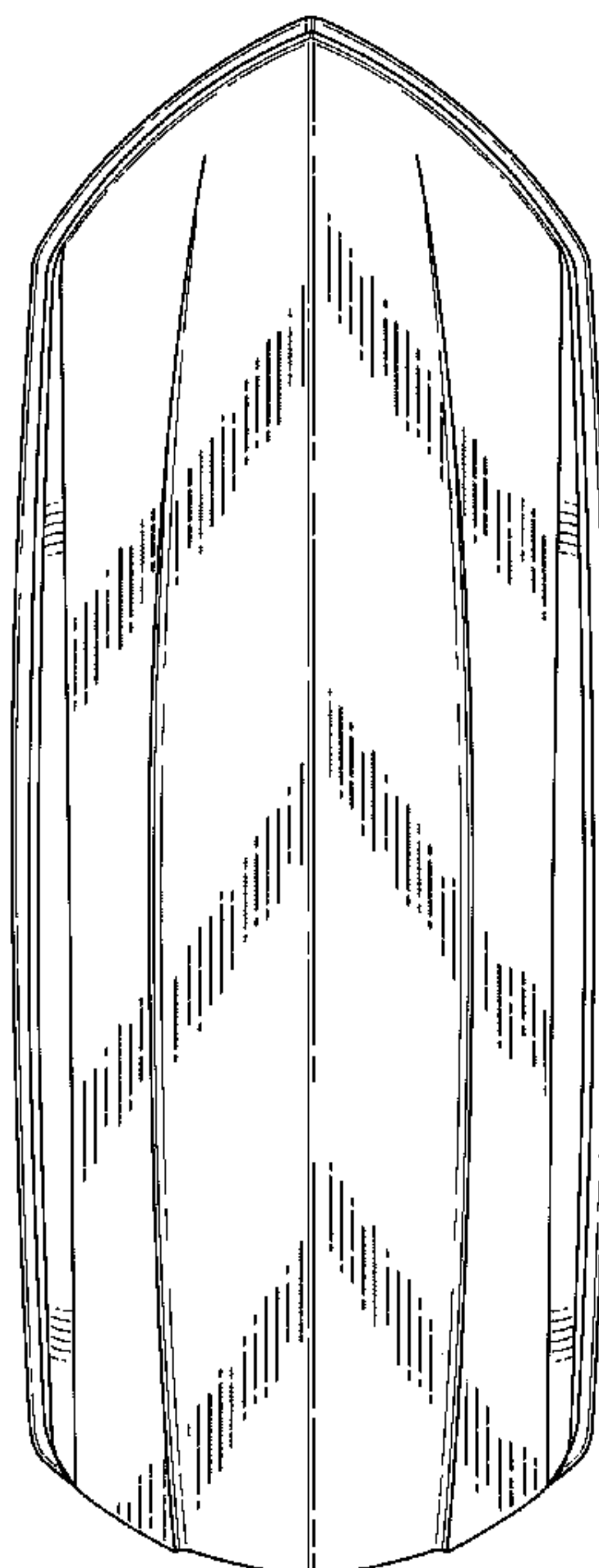

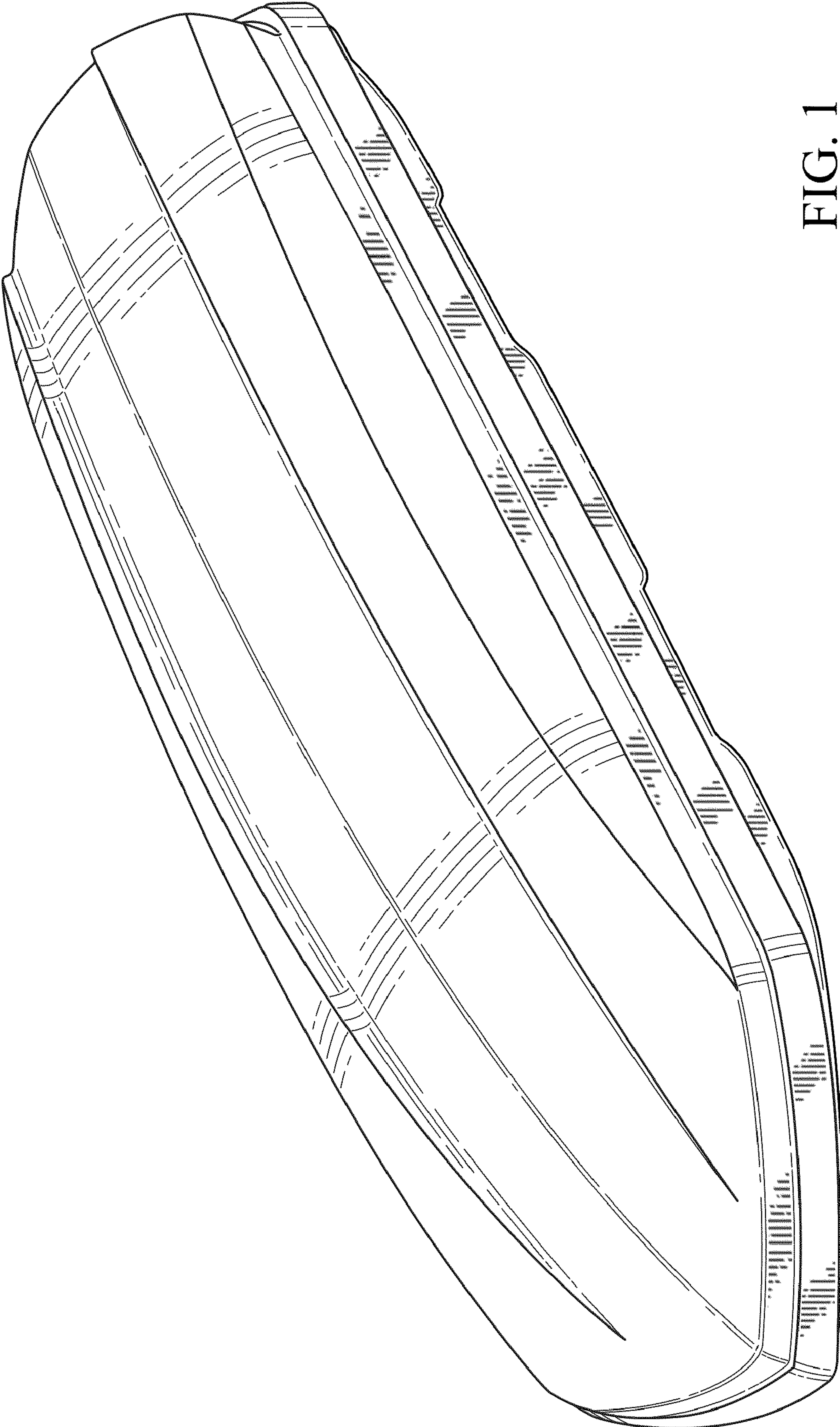

FIG. 1

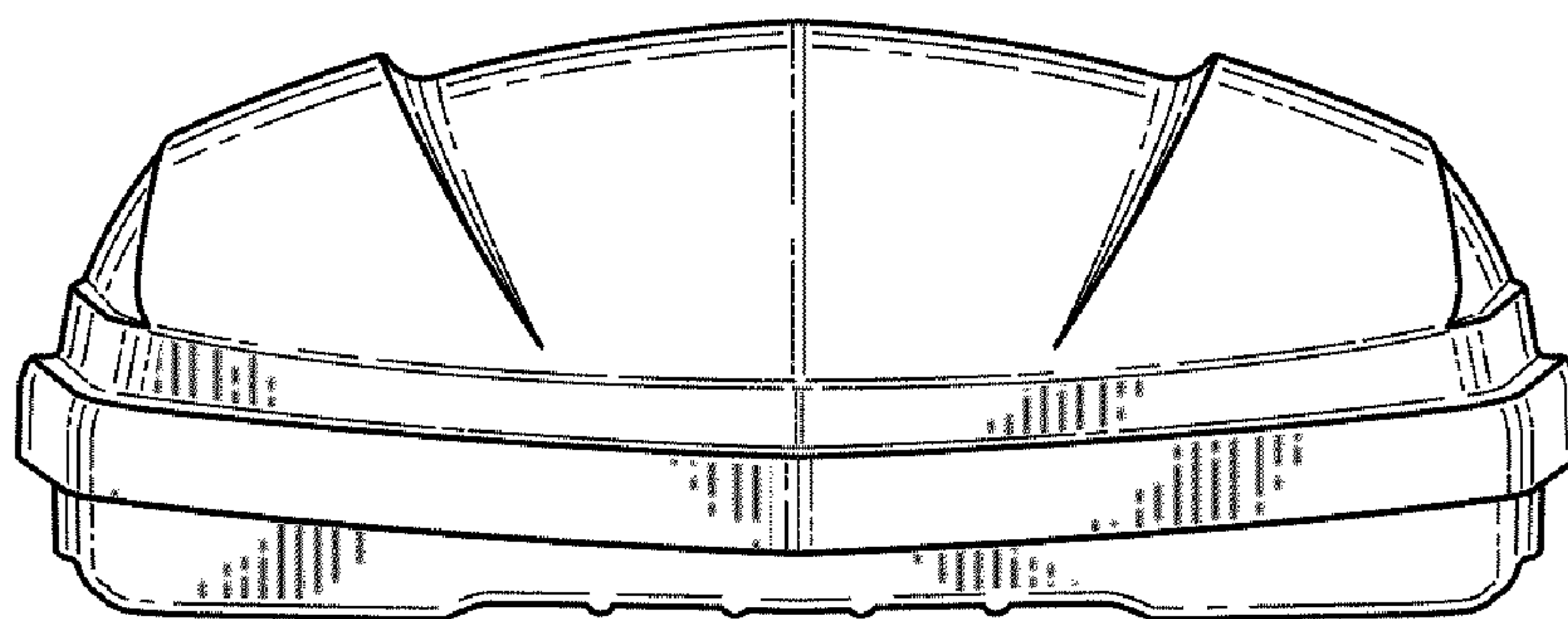

FIG. 2

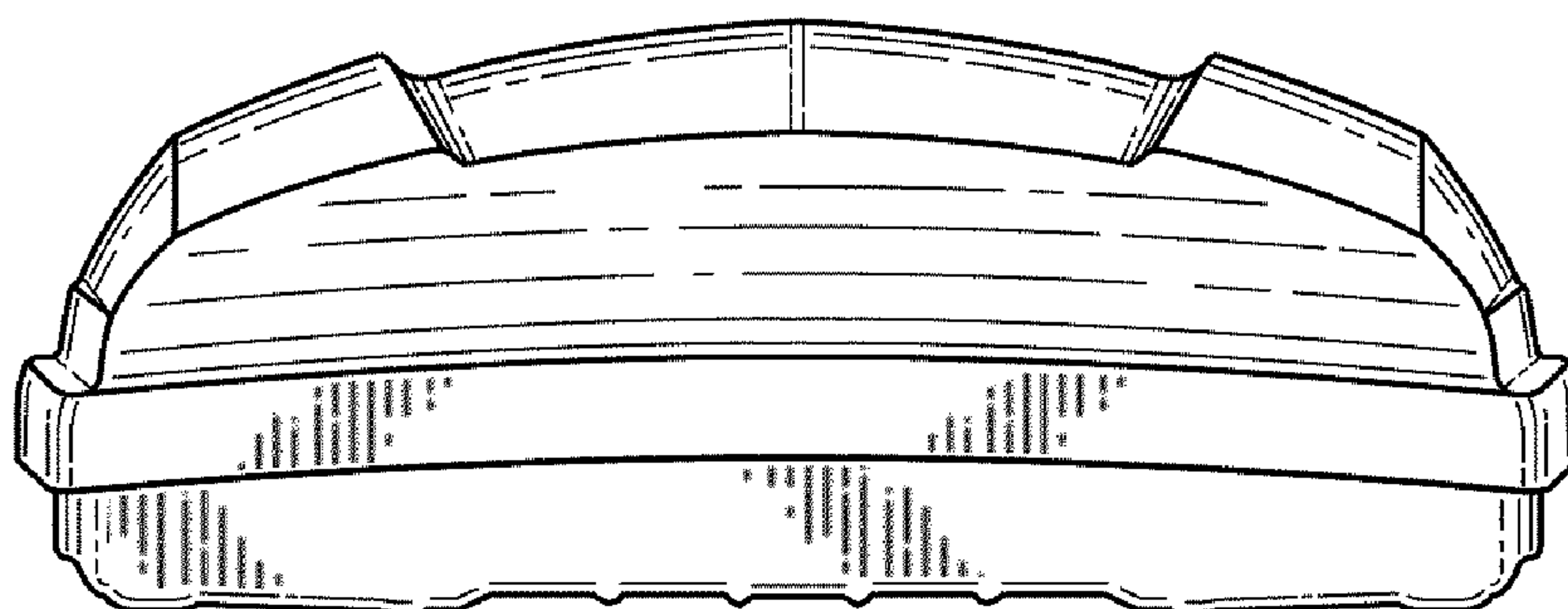

FIG. 3

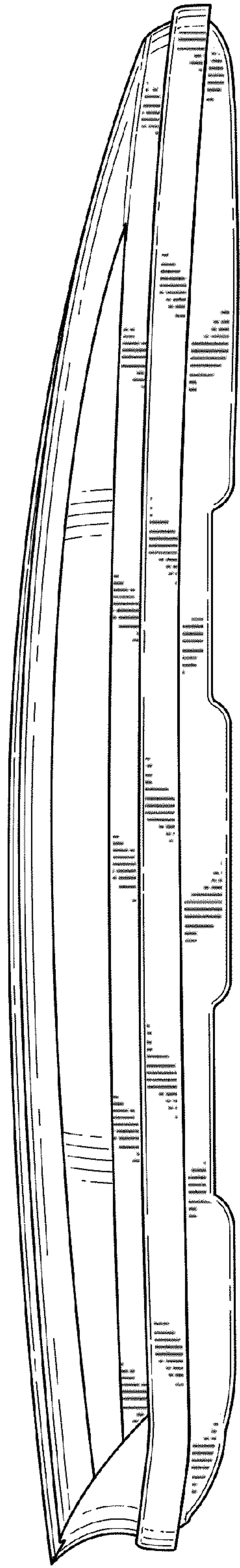

FIG. 4

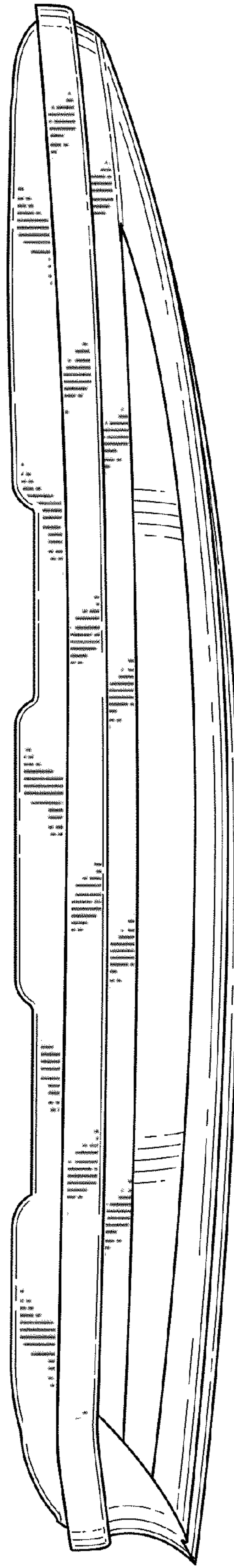

FIG. 5

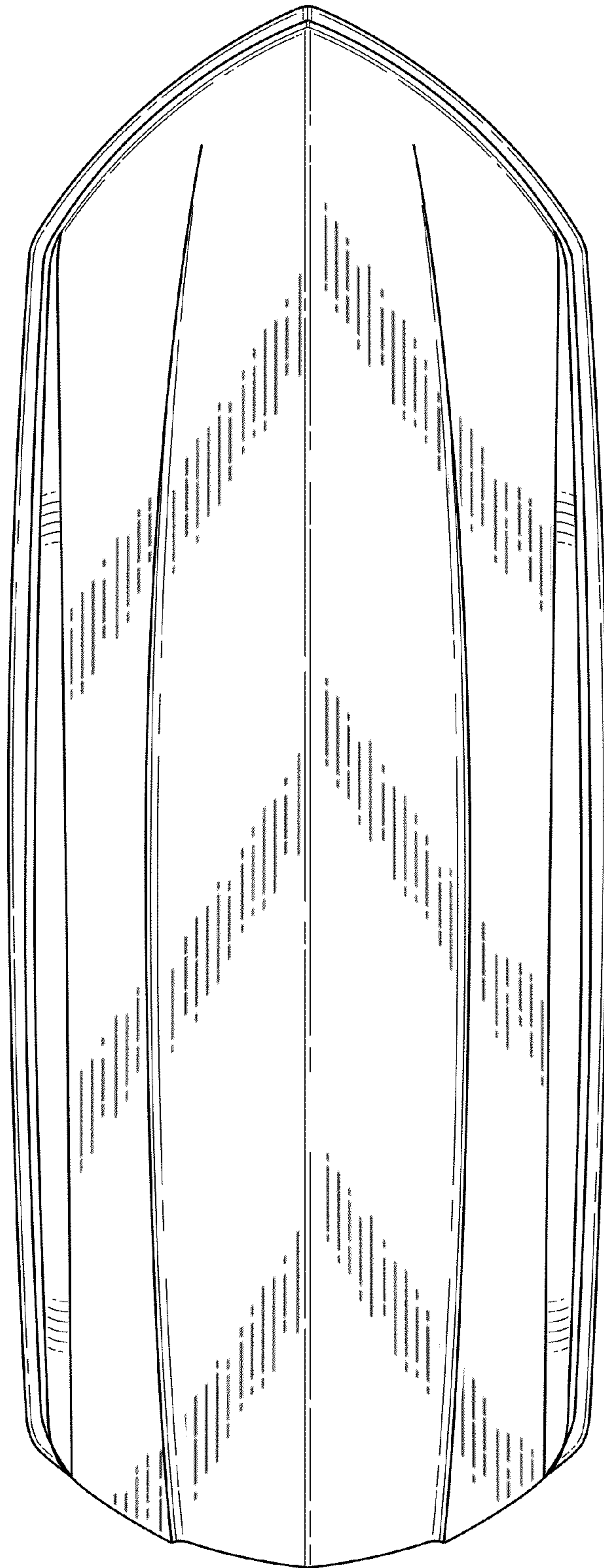

FIG. 6

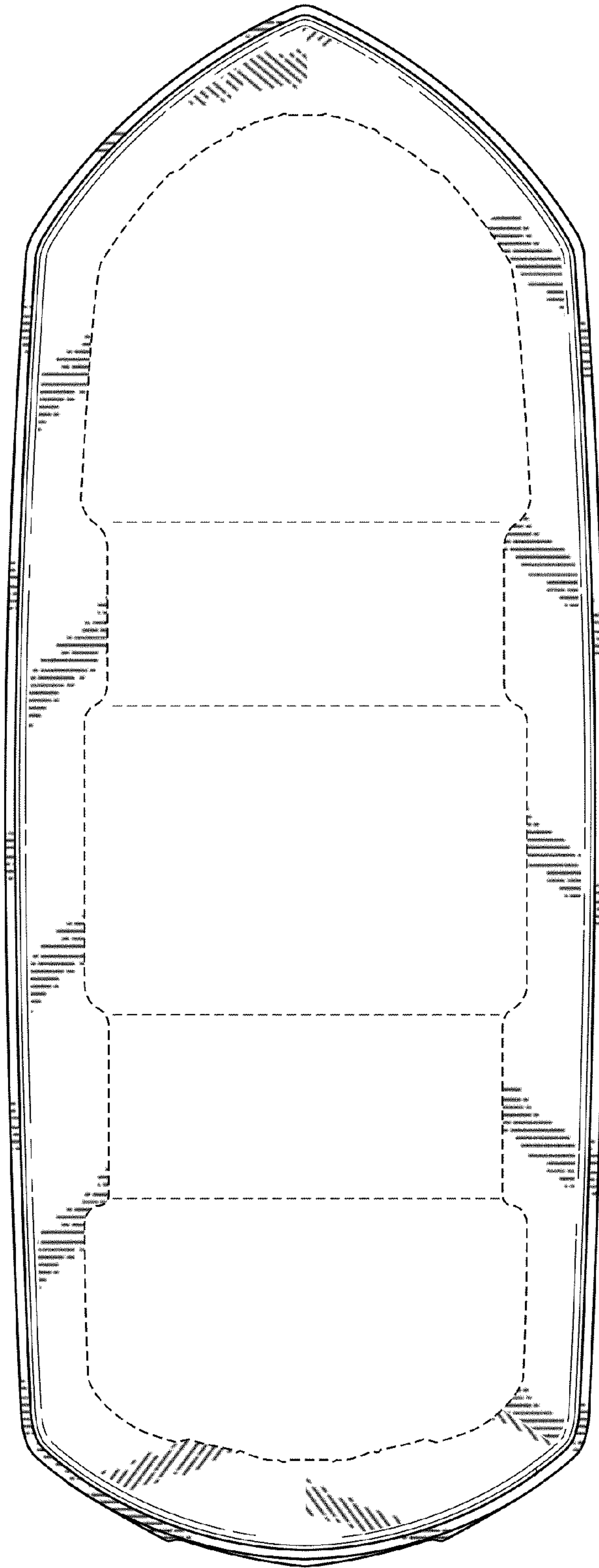

FIG. 7

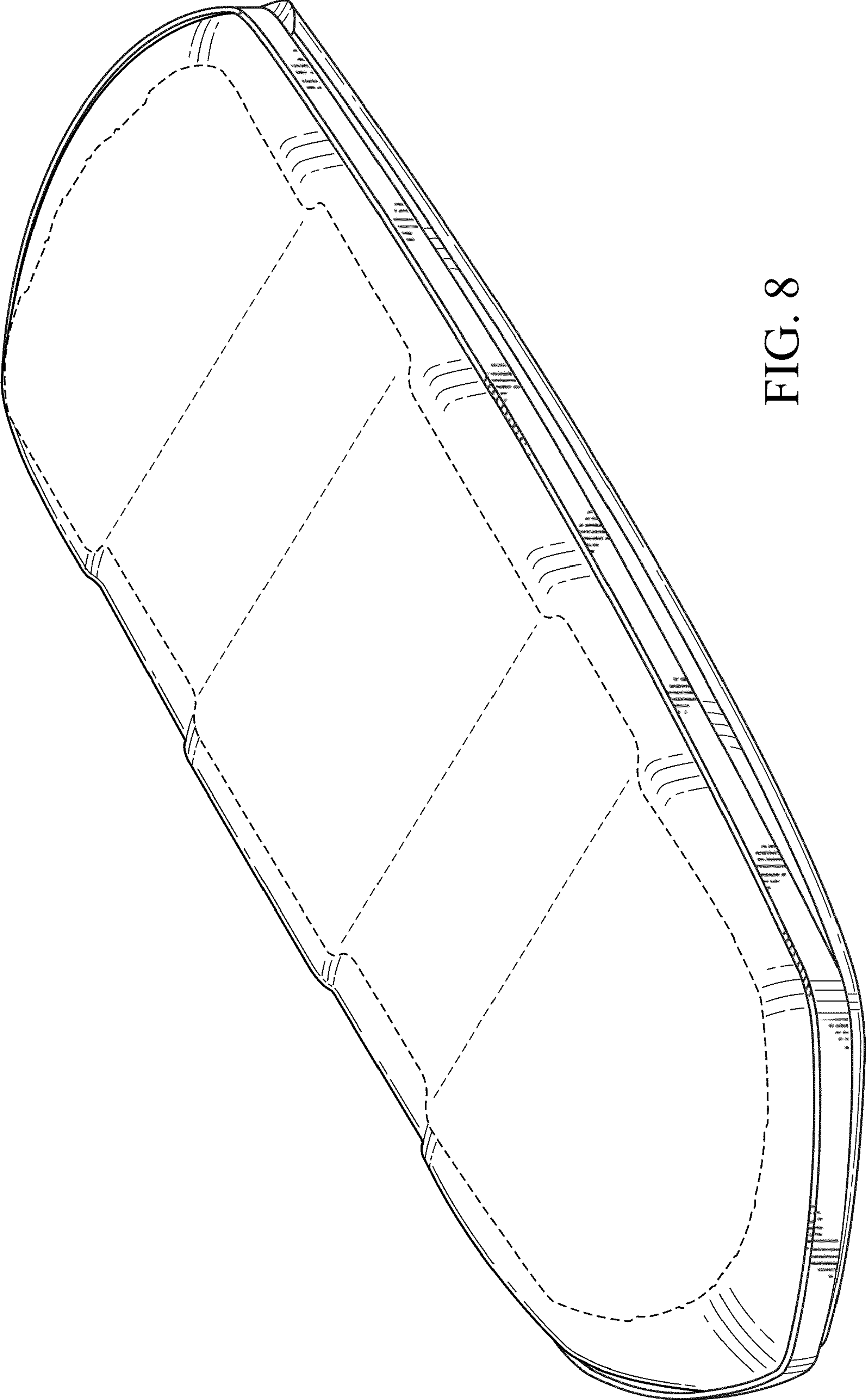

FIG. 8