

US00D643674S

(12) **United States Design Patent**
Lee et al.

(10) **Patent No.:** **US D643,674 S**

(45) **Date of Patent:** **** Aug. 23, 2011**

(54) **PORTABLE RANGE**

(75) Inventors: **Gilock Lee**, Seoul (KR); **Jung Kyung Kwack**, Seoul (KR)

(73) Assignee: **Samsung Electronics Co., Ltd.**, Suwon-Si (KR)

(**) Term: **14 Years**

(21) Appl. No.: **29/381,292**

(22) Filed: **Dec. 17, 2010**

(51) **LOC (9) Cl.** **07-02**

(52) **U.S. Cl.** **D7/363; D7/362**

(58) **Field of Classification Search** D7/309,
D7/323, 328-332, 334-341, 346-348, 350.1,
D7/350.4, 351-367, 407; D15/146; D24/206;
99/324-327, 331, 339-341, 349, 353, 369,
99/372-377, 385-393, 425, 444, 446; 126/25 B,
126/25 R, 30, 41 R; 219/448.11, 450.1, 524-525,
219/620-622, 732-734

See application file for complete search history.

(56) **References Cited**

U.S. PATENT DOCUMENTS

D139,751 S	*	12/1944	Springwell	D7/363
D195,657 S	*	7/1963	Sullivan	D7/364
D205,820 S	*	9/1966	Ryan	D7/364
D233,066 S	*	10/1974	Bair	D15/146
D236,183 S	*	8/1975	Greger	D7/363
D249,864 S	*	10/1978	Mackay et al.	D7/364
D261,849 S	*	11/1981	Funaki et al.	D7/367

D285,523 S	*	9/1986	Ayukawa et al.	D7/367
D289,130 S	*	4/1987	Rengeji et al.	D7/363
D289,847 S	*	5/1987	Okamoto et al.	D7/363
D296,509 S	*	7/1988	Fuke	D7/363
D297,701 S	*	9/1988	Nakagawa et al.	D7/363
D312,748 S	*	12/1990	Jung et al.	D7/407
D326,387 S	*	5/1992	Monitto et al.	D7/346
D366,390 S	*	1/1996	Vitantonio	D7/363
D501,117 S	*	1/2005	Bassill	D7/367
D533,016 S	*	12/2006	Genslak et al.	D7/363
D568,672 S	*	5/2008	Craig et al.	D7/346
D575,098 S	*	8/2008	Seymour	D7/363
D580,701 S	*	11/2008	Wojcik et al.	D7/367
D602,597 S	*	10/2009	Nomi et al.	D24/206

* cited by examiner

Primary Examiner — Ricky Pham

(74) *Attorney, Agent, or Firm* — Ladas & Parry LLP

(57) **CLAIM**

The ornamental design for a portable range, as shown and described.

DESCRIPTION

FIG. 1 is a front/right-side/top perspective view of a portable range showing our new design;

FIG. 2 is a front-side elevational view thereof;

FIG. 3 is a rear-side elevational view thereof;

FIG. 4 is a left-side elevational view thereof;

FIG. 5 is a right-side elevational view thereof;

FIG. 6 is a top plan view thereof; and,

FIG. 7 is a bottom plan view thereof.

1 Claim, 4 Drawing Sheets

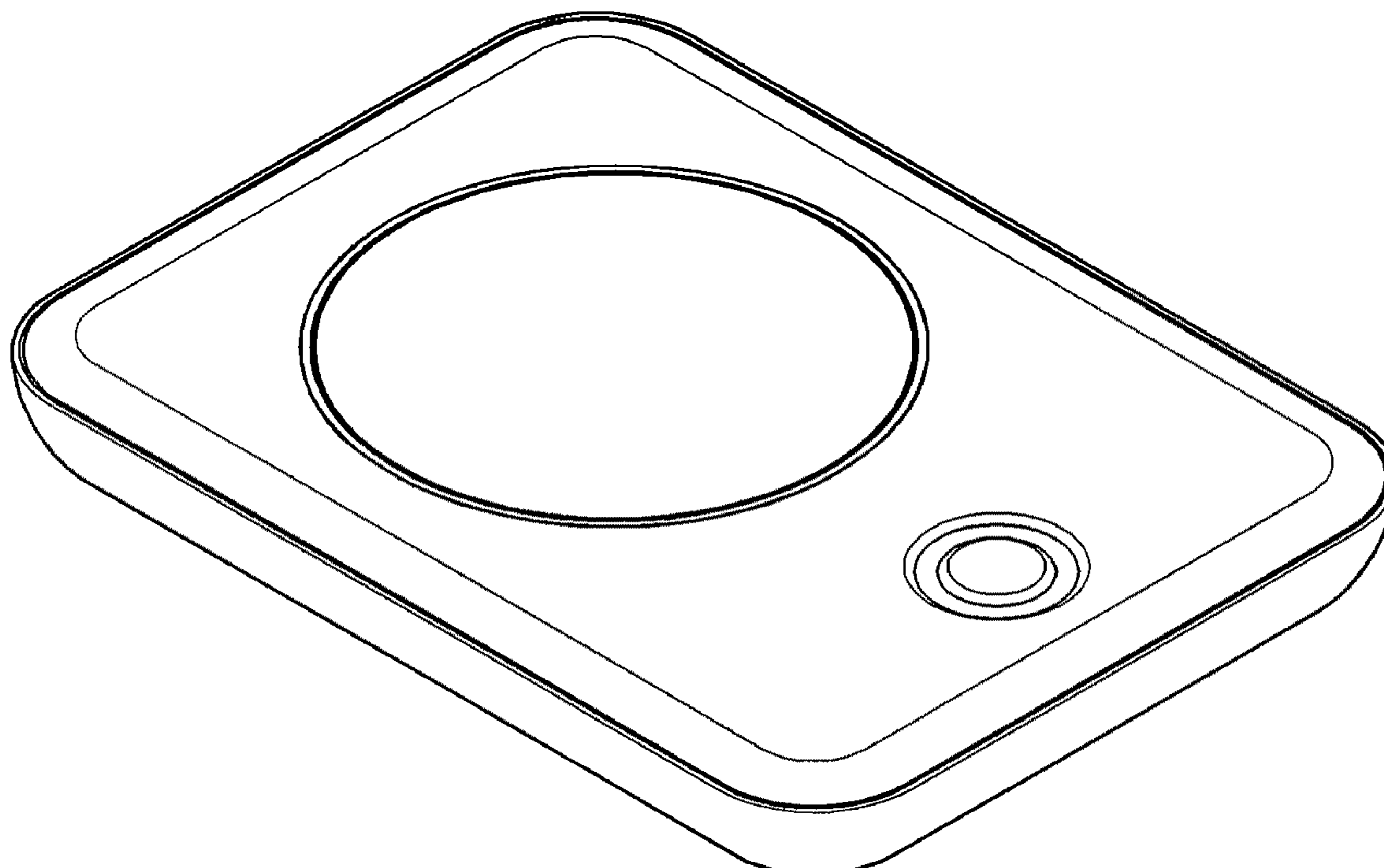

FIG. 1

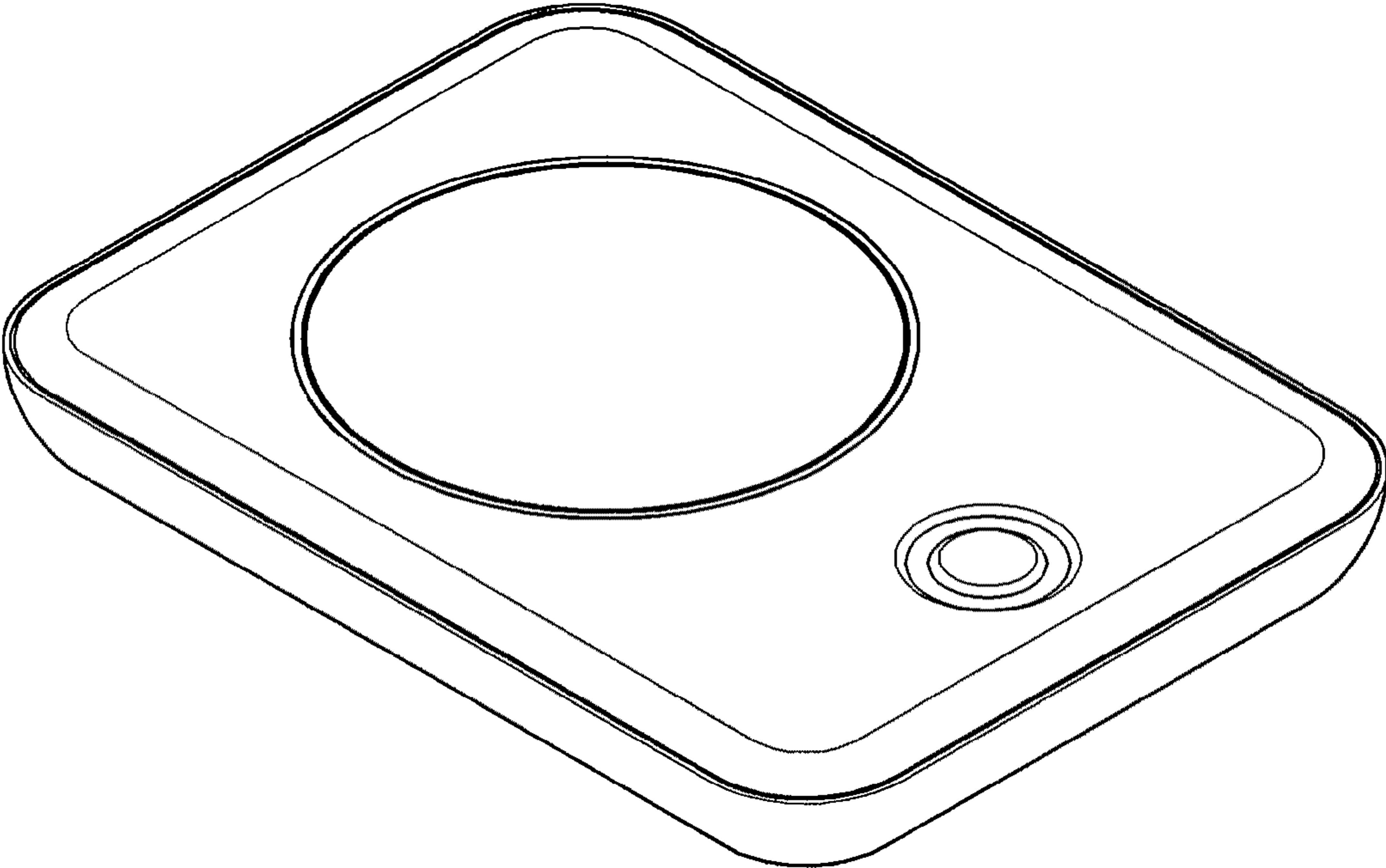

FIG. 2

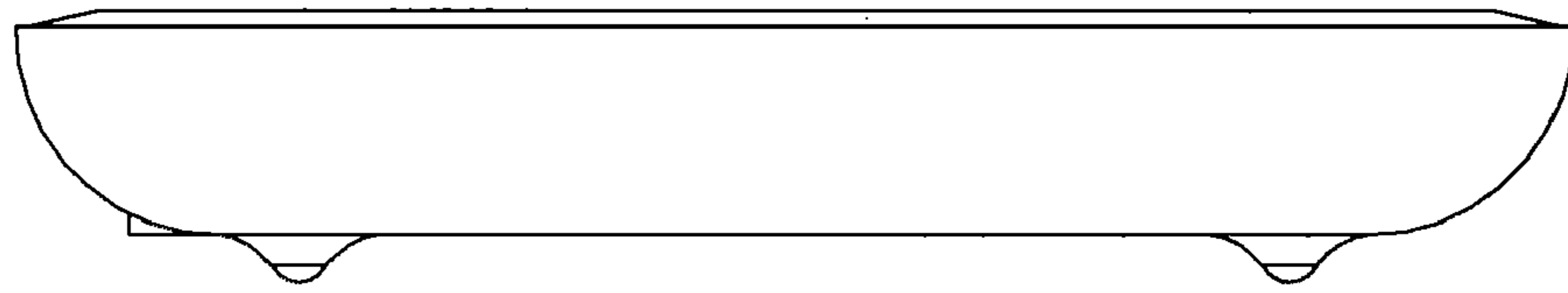

FIG. 3

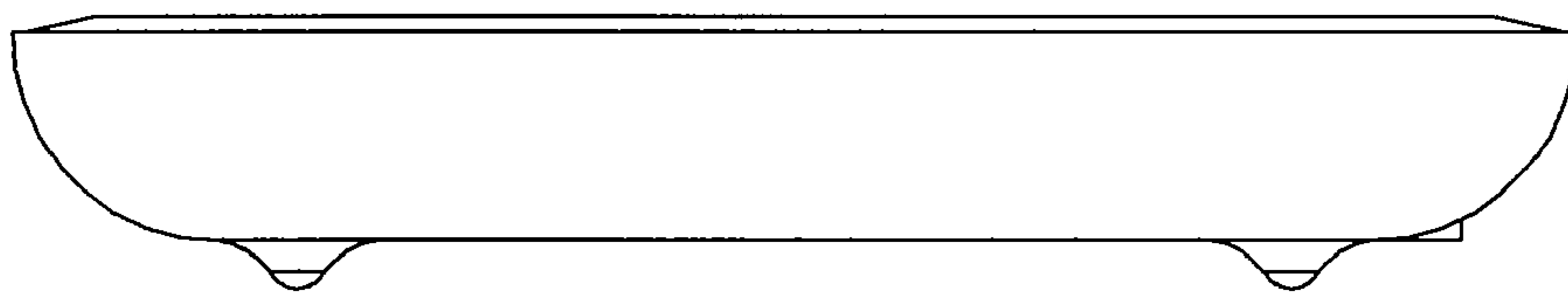

FIG. 4

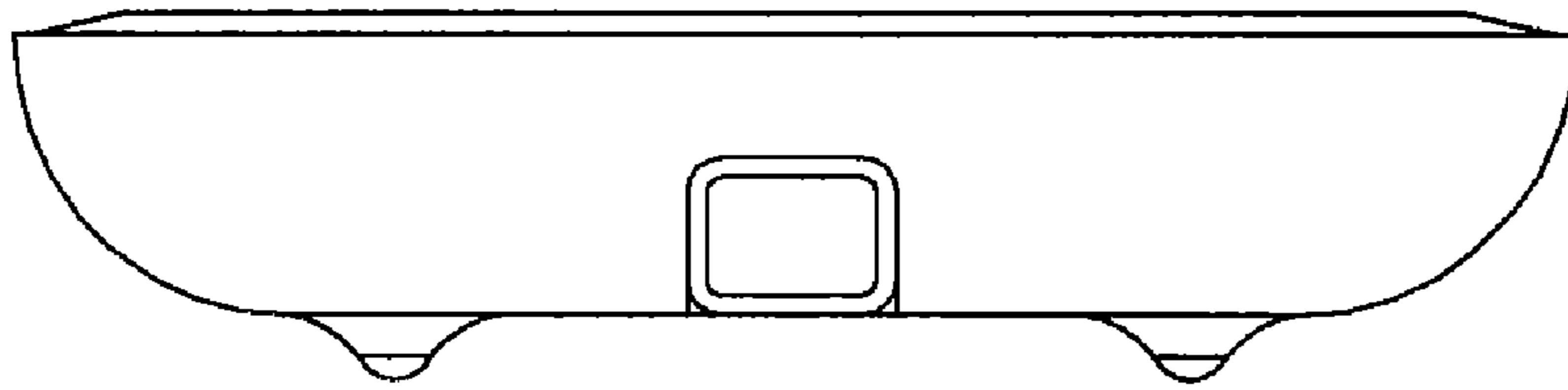

FIG. 5

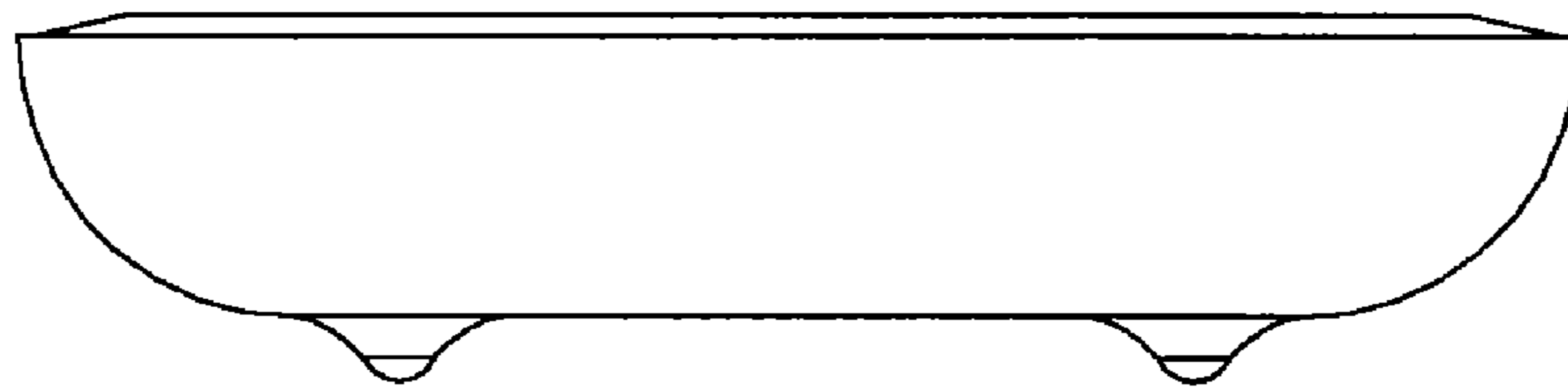

FIG. 6

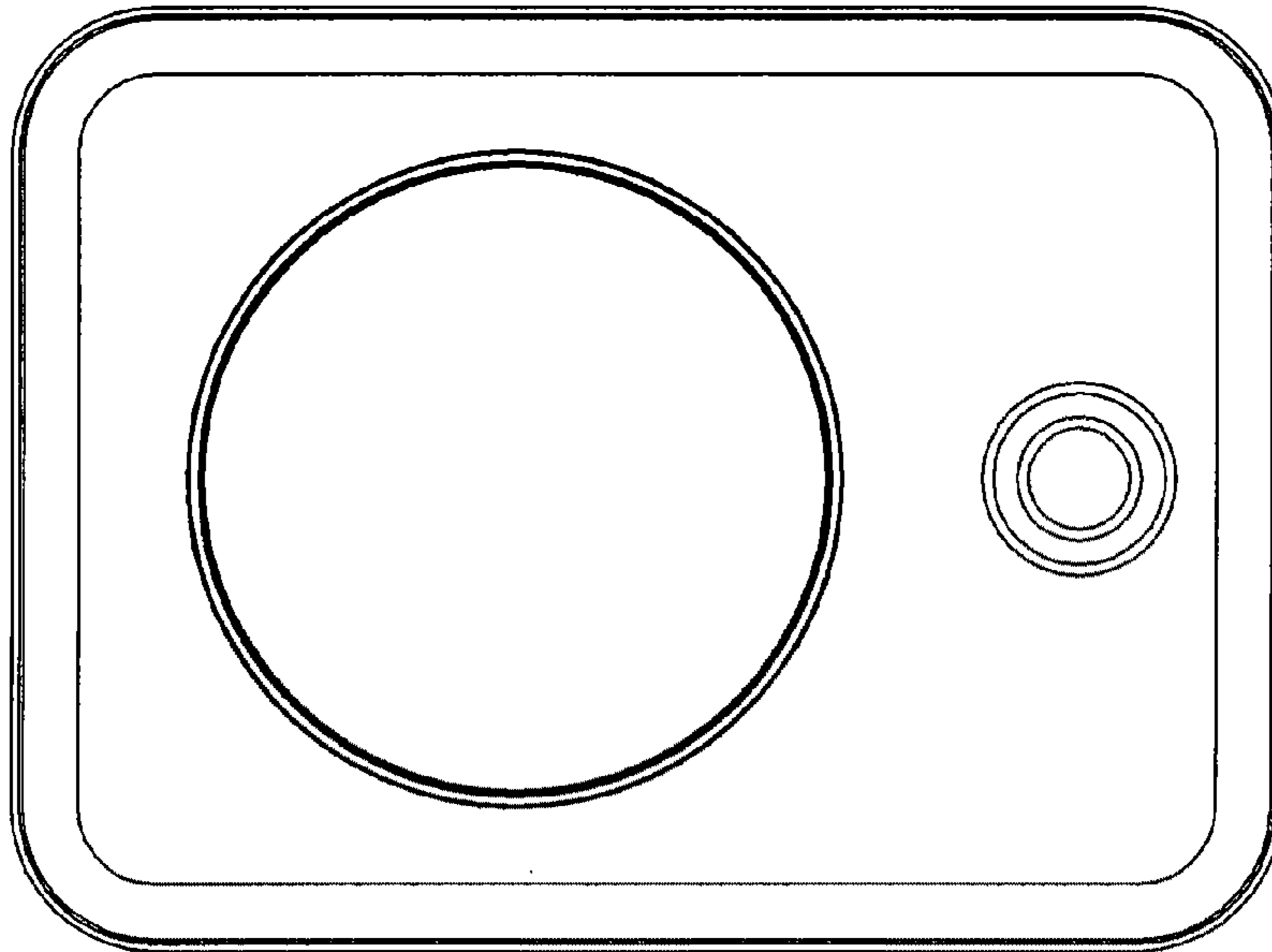

FIG. 7

