



US00D643442S

(12) **United States Design Patent**  
**Sato et al.**

(10) **Patent No.:** **US D643,442 S**  
(45) **Date of Patent:** **\*\* Aug. 16, 2011**

(54) **CYLINDER-TYPE INFLATOR FOR AIRBAG MODULE**

(75) Inventors: **Eishi Sato**, Himeji (JP); **Naoki Izaki**, Himeji (JP); **Satoshi Aoyagi**, Himeji (JP); **Daisuke Hagihara**, Himeji (JP); **Koichi Enami**, Himeji (JP); **Koichi Sasamoto**, Himeji (JP)

(73) Assignee: **Nippon Kayaku Kabushiki Kaisha**, Tokyo (JP)

(\*\*) Term: **14 Years**

(21) Appl. No.: **29/354,908**

(22) Filed: **Jan. 29, 2010**

(30) **Foreign Application Priority Data**

Jul. 31, 2009	(JP)	.....	2009-017660
Jul. 31, 2009	(JP)	.....	2009-017661
Jul. 31, 2009	(JP)	.....	2009-017662
Jul. 31, 2009	(JP)	.....	2009-017663

(51) **LOC (9) Cl.** ..... **15-02**

(52) **U.S. Cl.** ..... **D15/9**

(58) **Field of Classification Search** ..... D15/7-9;  
D23/231, 232, 225; 417/410.1, 359, 415-416,  
417/234, 321, 265, 405

See application file for complete search history.

(56) **References Cited**

**U.S. PATENT DOCUMENTS**

D304,970 S \* 12/1989 Gibb ..... D23/231  
(Continued)

**FOREIGN PATENT DOCUMENTS**

JP	3134281	7/2007
JP	2008-247301	10/2008

**OTHER PUBLICATIONS**

Office Action issued Oct. 4, 2010, in Japan Patent Application No. 2009-017660 (with English-language Translation).

(Continued)

*Primary Examiner* — Ralf Seifert

(74) *Attorney, Agent, or Firm* — Oblon, Spivak, McClelland, Maier & Neustadt, L.L.P.

(57) **CLAIM**

The ornamental design for a cylinder-type inflator for airbag module, as shown and described.

**DESCRIPTION**

FIG. 1 is a front elevational view of a first embodiment of a cylinder-type inflator for airbag module;  
 FIG. 2 is a rear elevational view thereof;  
 FIG. 3 is a top plan view thereof;  
 FIG. 4 is a bottom plan view thereof;  
 FIG. 5 is a right side elevational view thereof;  
 FIG. 6 is a left side elevational view thereof;  
 FIG. 7 is a top, front, and left side perspective view thereof;  
 FIG. 8 is a bottom, rear, and right side perspective view thereof;  
 FIG. 9 is a front elevational view of a second embodiment of a cylinder-type inflator for airbag module;  
 FIG. 10 is a rear elevational view thereof;  
 FIG. 11 is a top plan view thereof;  
 FIG. 12 is a bottom plan view thereof;  
 FIG. 13 is a right side elevational view thereof;  
 FIG. 14 a left side elevational view thereof;  
 FIG. 15 is a top, front, and left side perspective view thereof;  
 FIG. 16 is a bottom, rear, and right side perspective view thereof;  
 FIG. 17 is a front elevational view of a third embodiment of a cylinder-type inflator for airbag module;  
 FIG. 18 is a rear elevational view thereof;  
 FIG. 19 is a top plan view thereof;  
 FIG. 20 is a bottom plan view thereof;  
 FIG. 21 is a right side elevational view thereof;  
 FIG. 22 is a left side elevational view thereof;  
 FIG. 23 is a top, front, and left side perspective view thereof;  
 and,  
 FIG. 24 is a bottom, rear, and right side perspective view thereof.

The broken lines in the drawings depict environmental subject matter only and form no part of the claimed design.

**1 Claim, 6 Drawing Sheets**

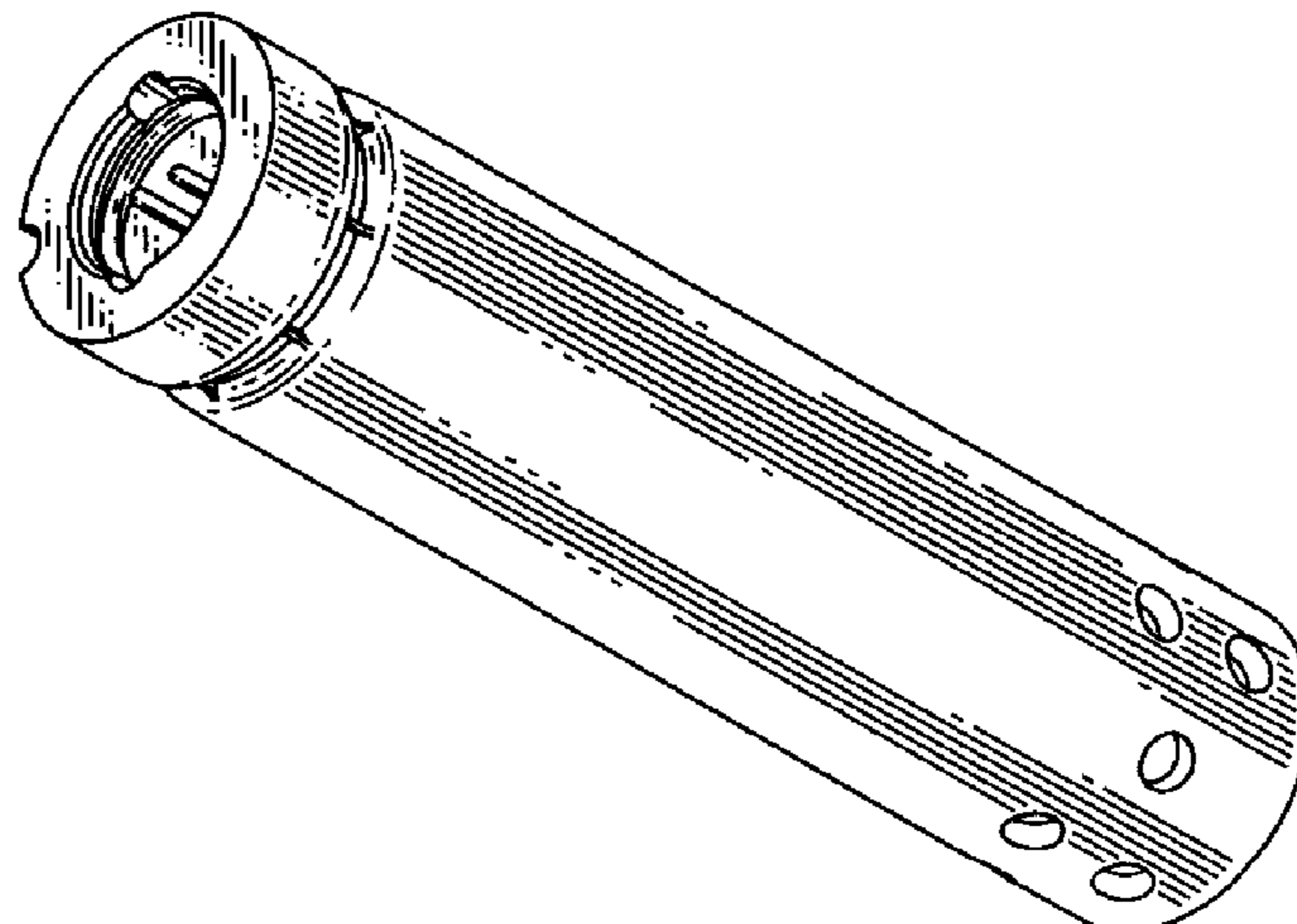

# US D643,442 S

Page 2

---

## U.S. PATENT DOCUMENTS

D355,199	S	*	2/1995	Ousey .....	D15/7
D461,827	S	*	8/2002	Koebbe .....	D15/7
D471,563	S	*	3/2003	Selic et al. ....	D15/7
D472,558	S	*	4/2003	MacPherson et al. ....	D15/7
D506,210	S	*	6/2005	Selic et al. ....	D15/7
D520,521	S	*	5/2006	Angeletta .....	D15/7
D540,349	S	*	4/2007	Waki .....	D15/9
D583,389	S	*	12/2008	Bilger .....	D15/7
D584,320	S	*	1/2009	Huang .....	D15/7
D589,984	S	*	4/2009	Roesler .....	D15/7

## OTHER PUBLICATIONS

Office Action issued Oct. 4, 2010, in Japan Patent Application No. 2009-017661 (with English-language Translation).  
Office Action issued Oct. 12, 2010, in Japan Patent Application No. 2009-017662 (with English-language Translation).  
Office Action issued Oct. 12, 2010, in Japan Patent Application No. 2009-017663 (with English-language Translation).

\* cited by examiner

FIG.1

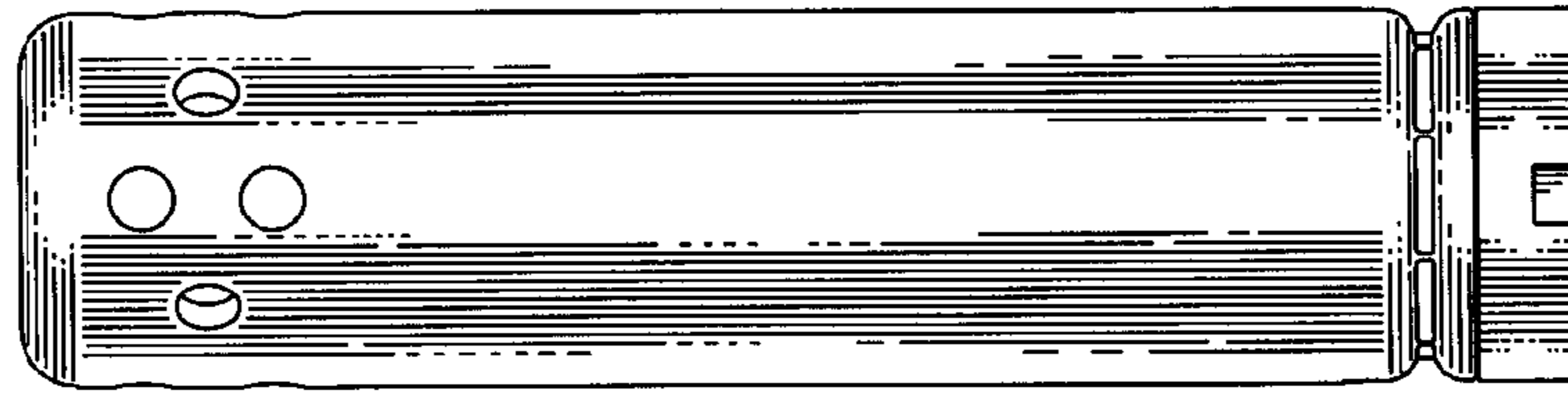

FIG.2

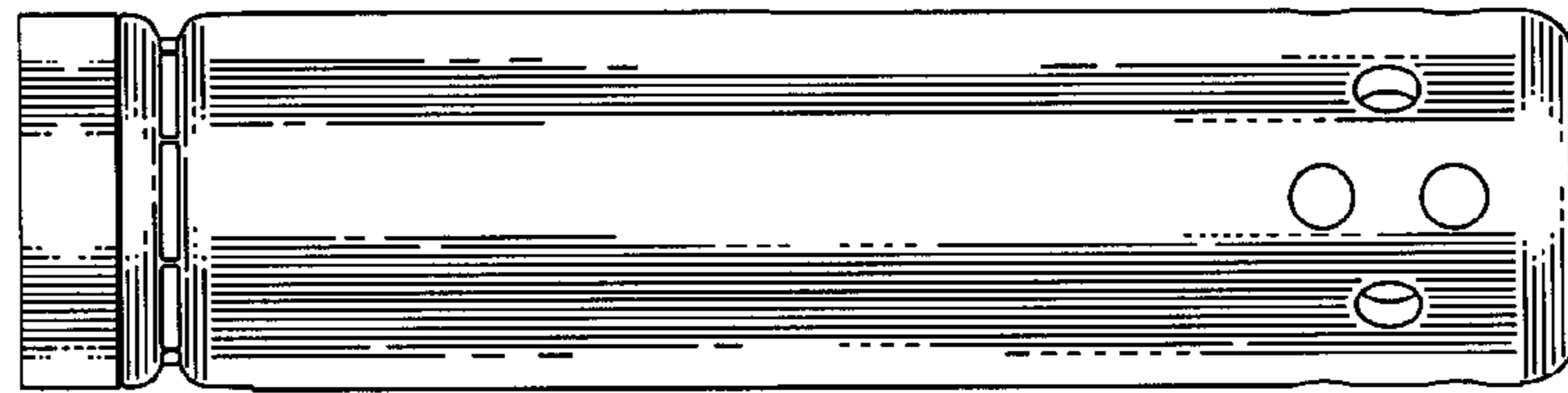

FIG.3

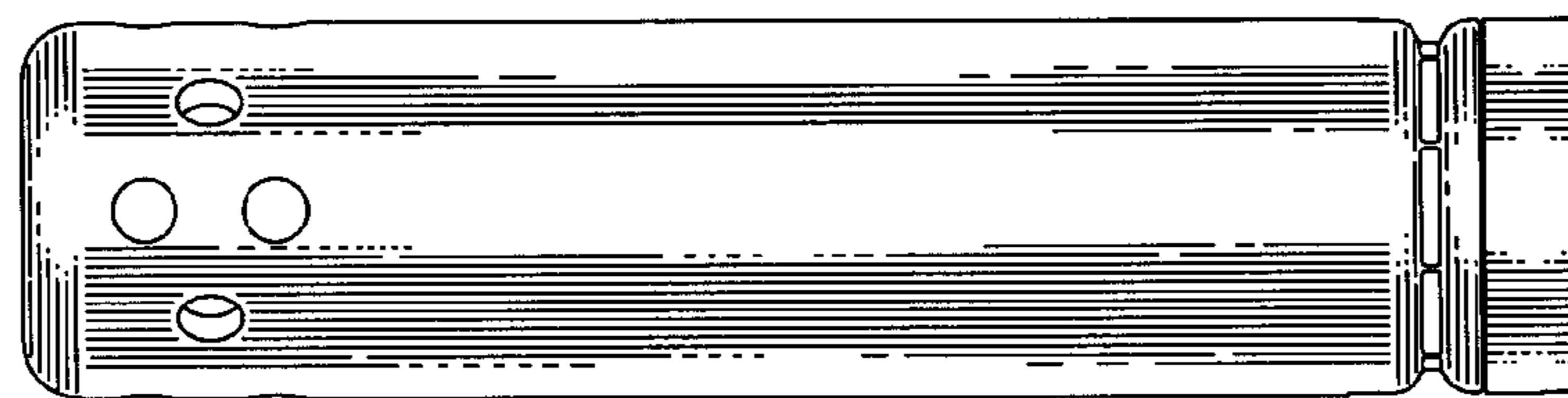

FIG.4

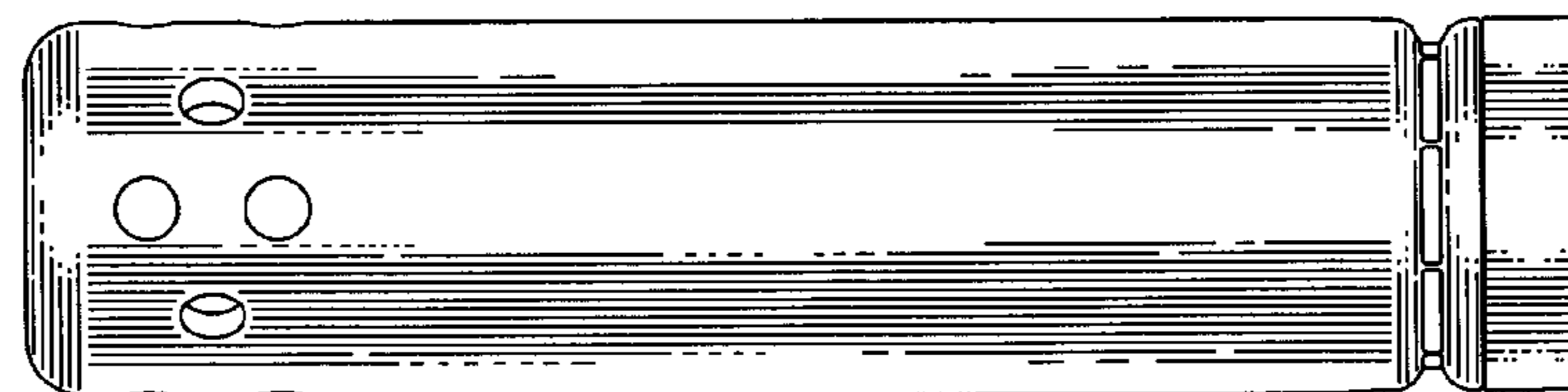

FIG.5

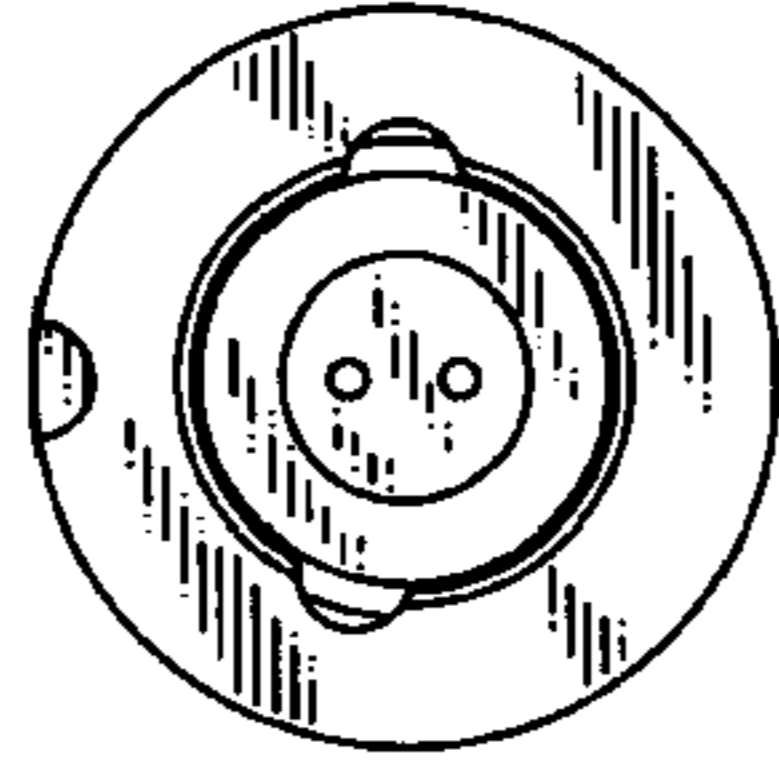

FIG.6

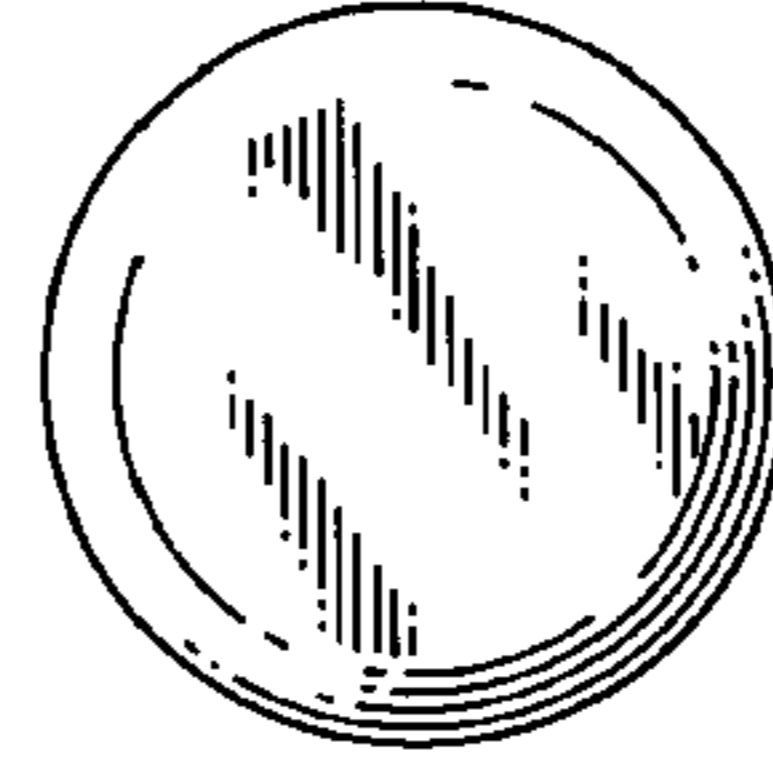

FIG.7

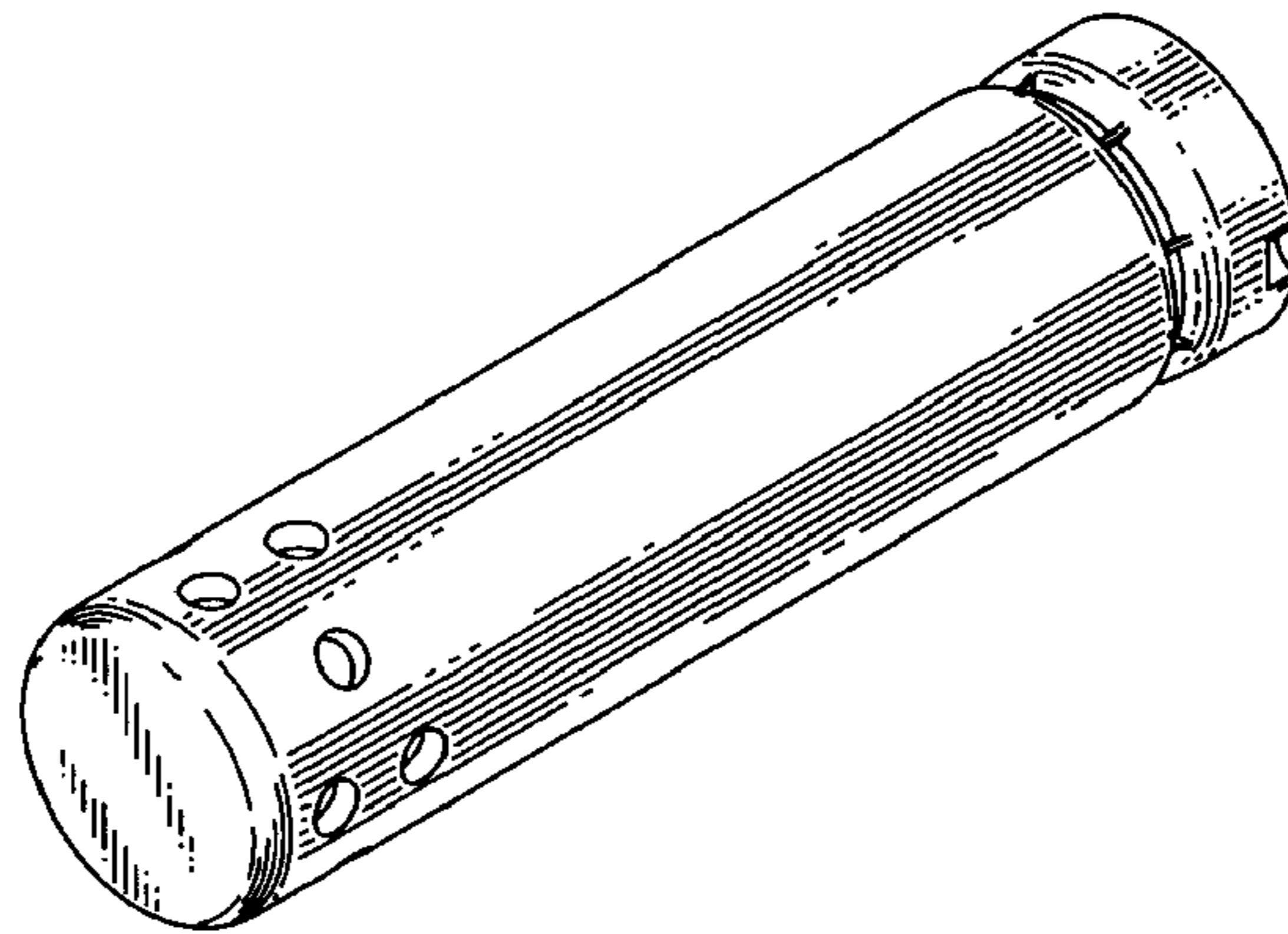

FIG.8

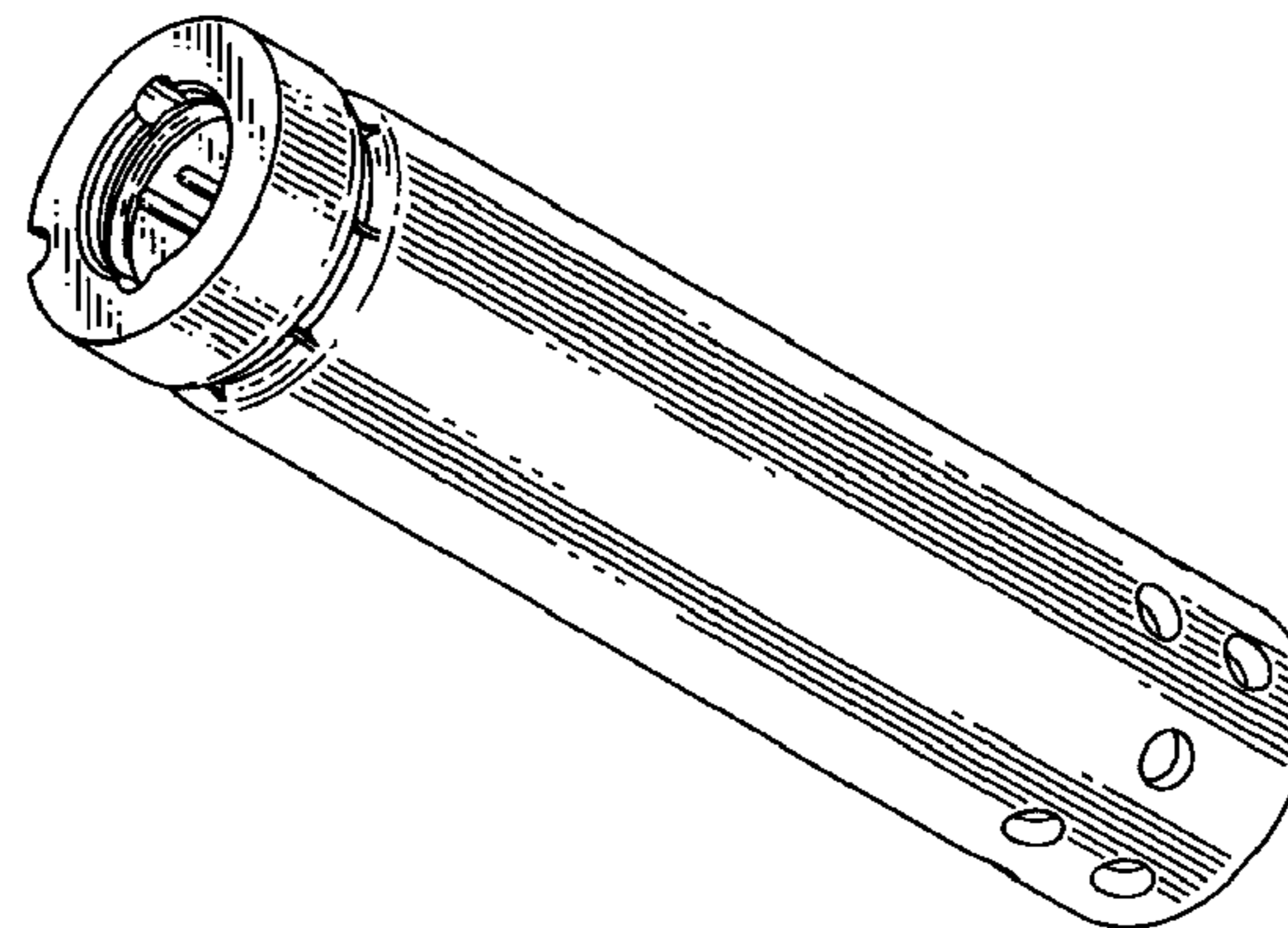

FIG.9

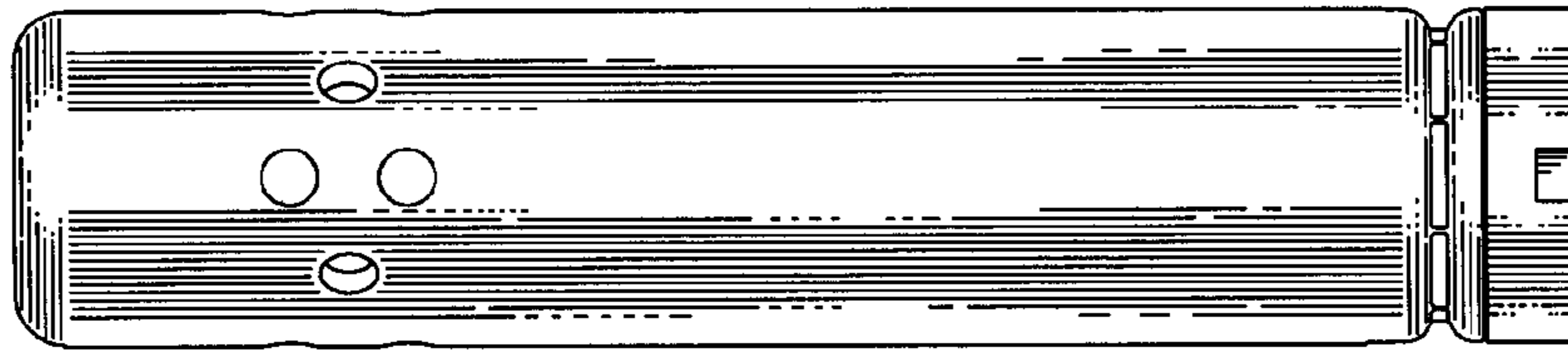

FIG.10

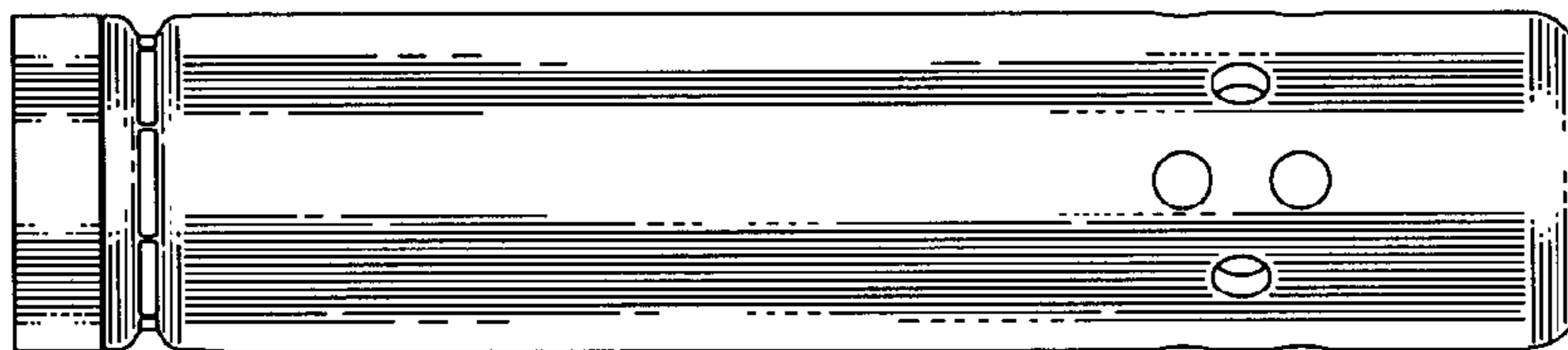

FIG.11

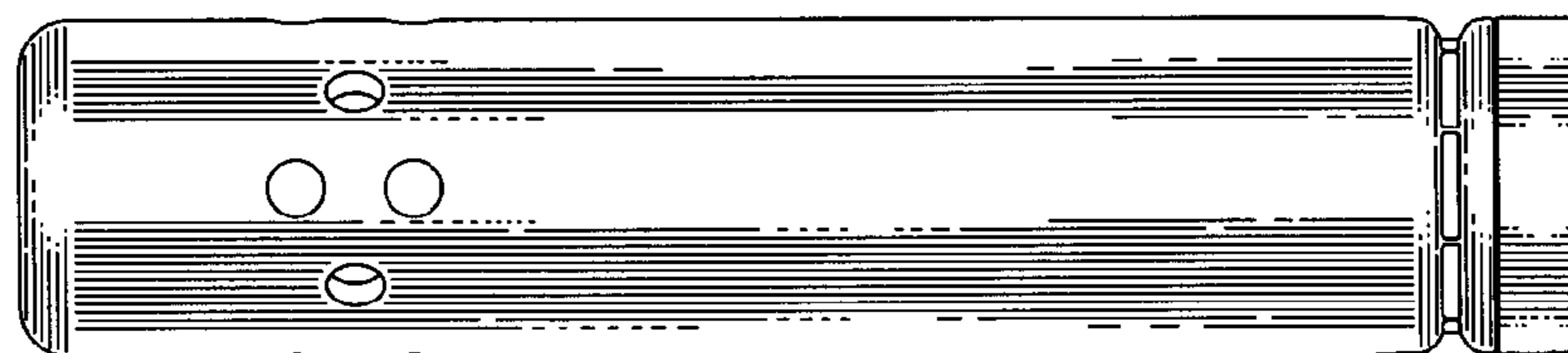

FIG.12

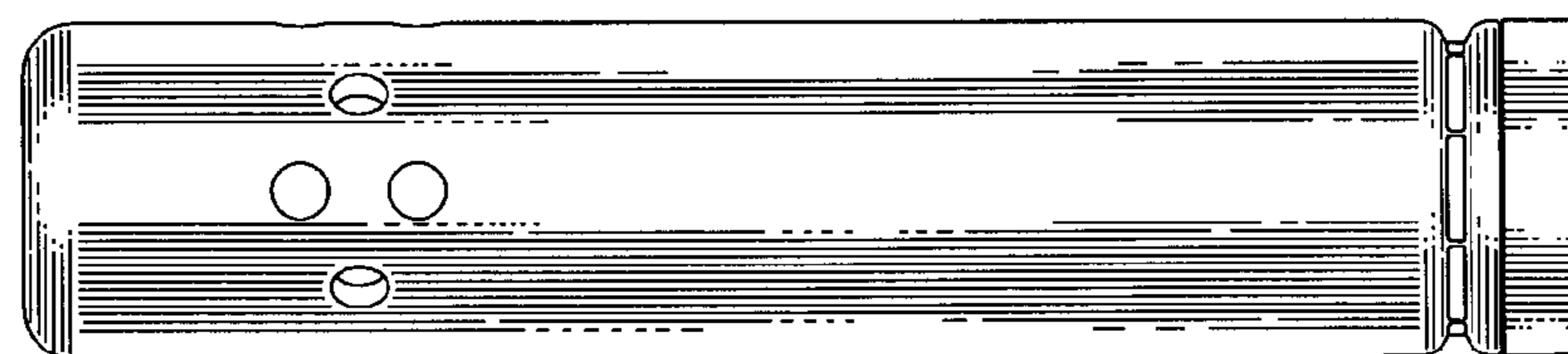

FIG.13

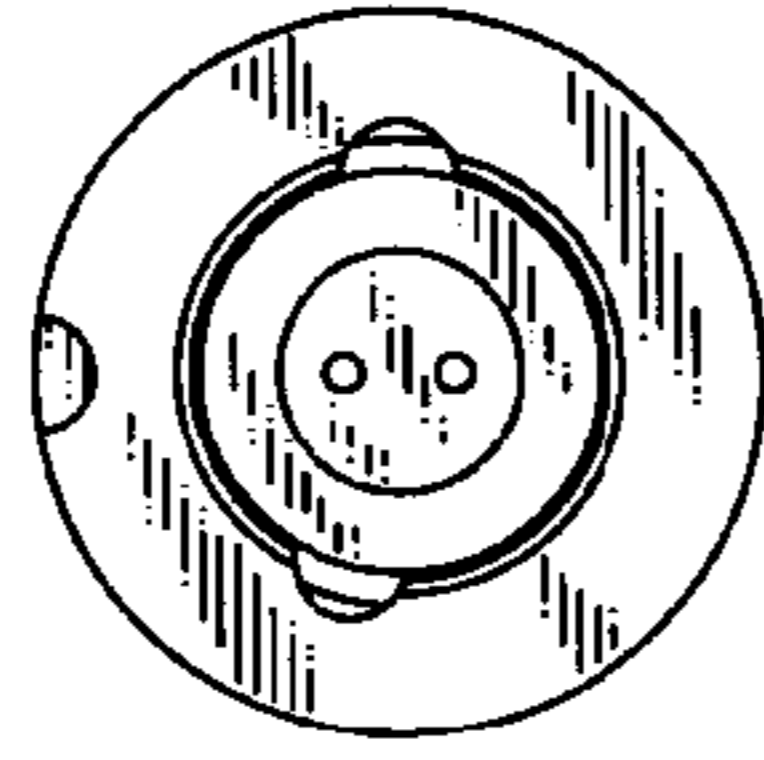

FIG.14

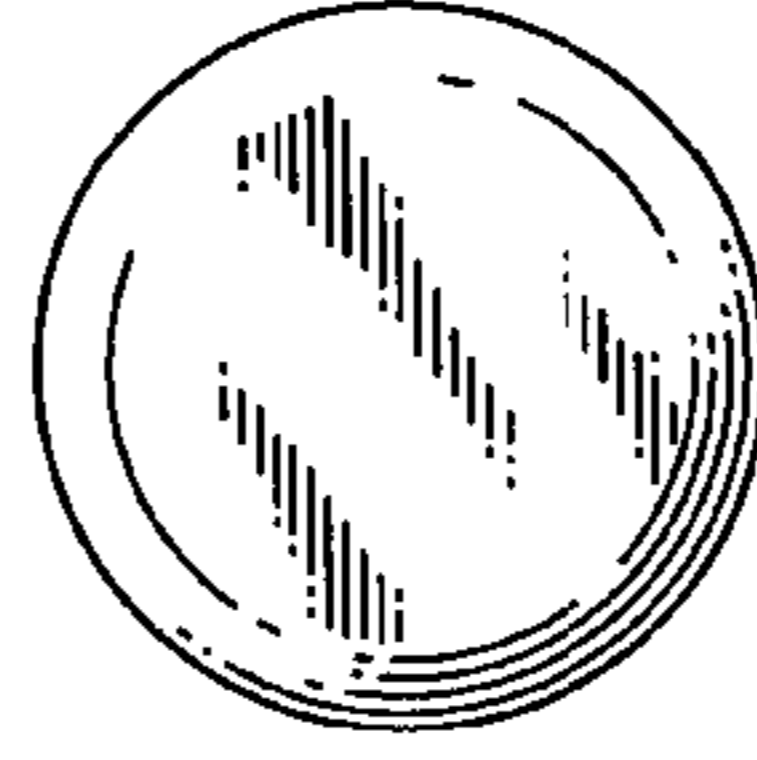

FIG.15

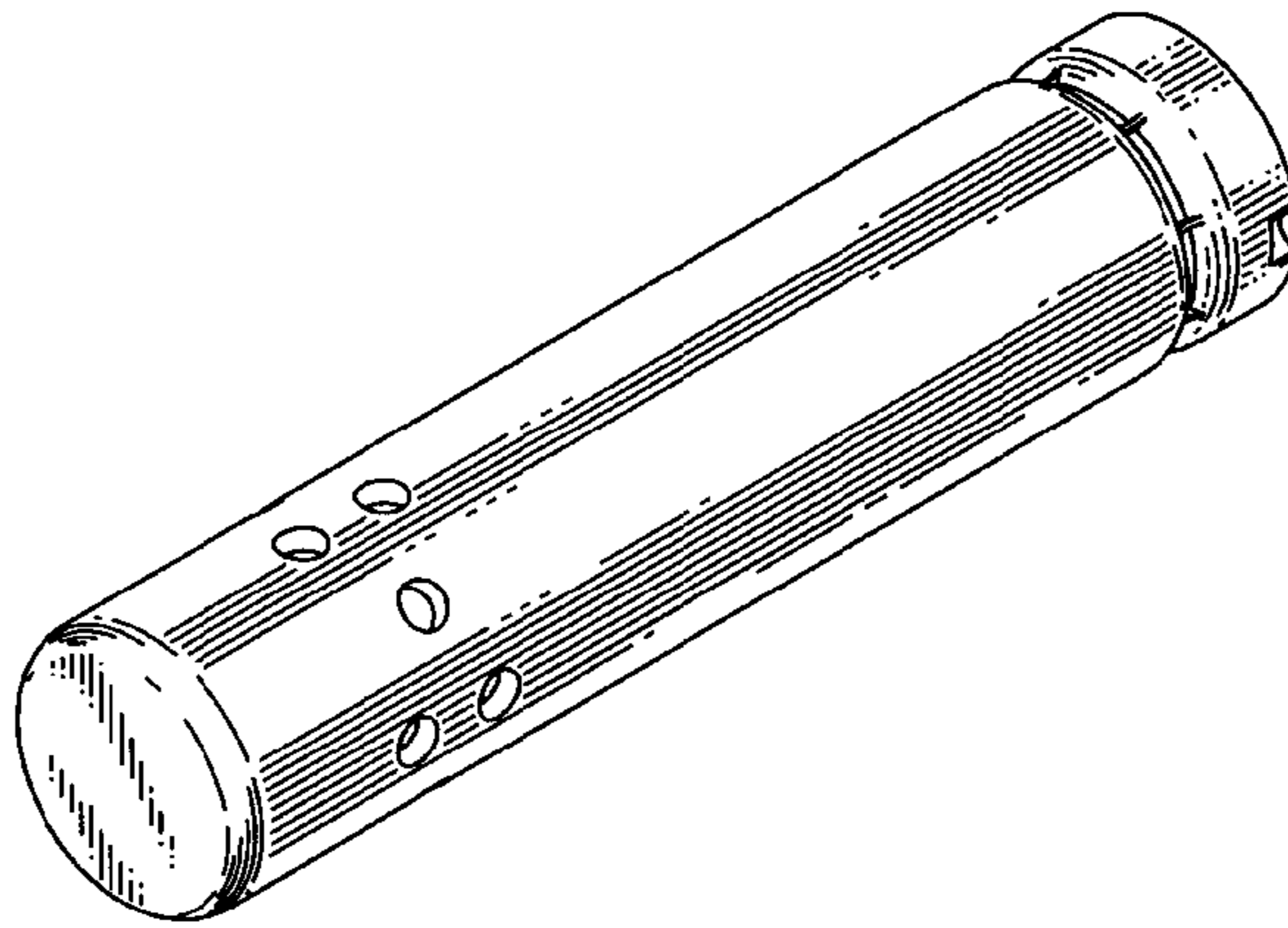

FIG.16

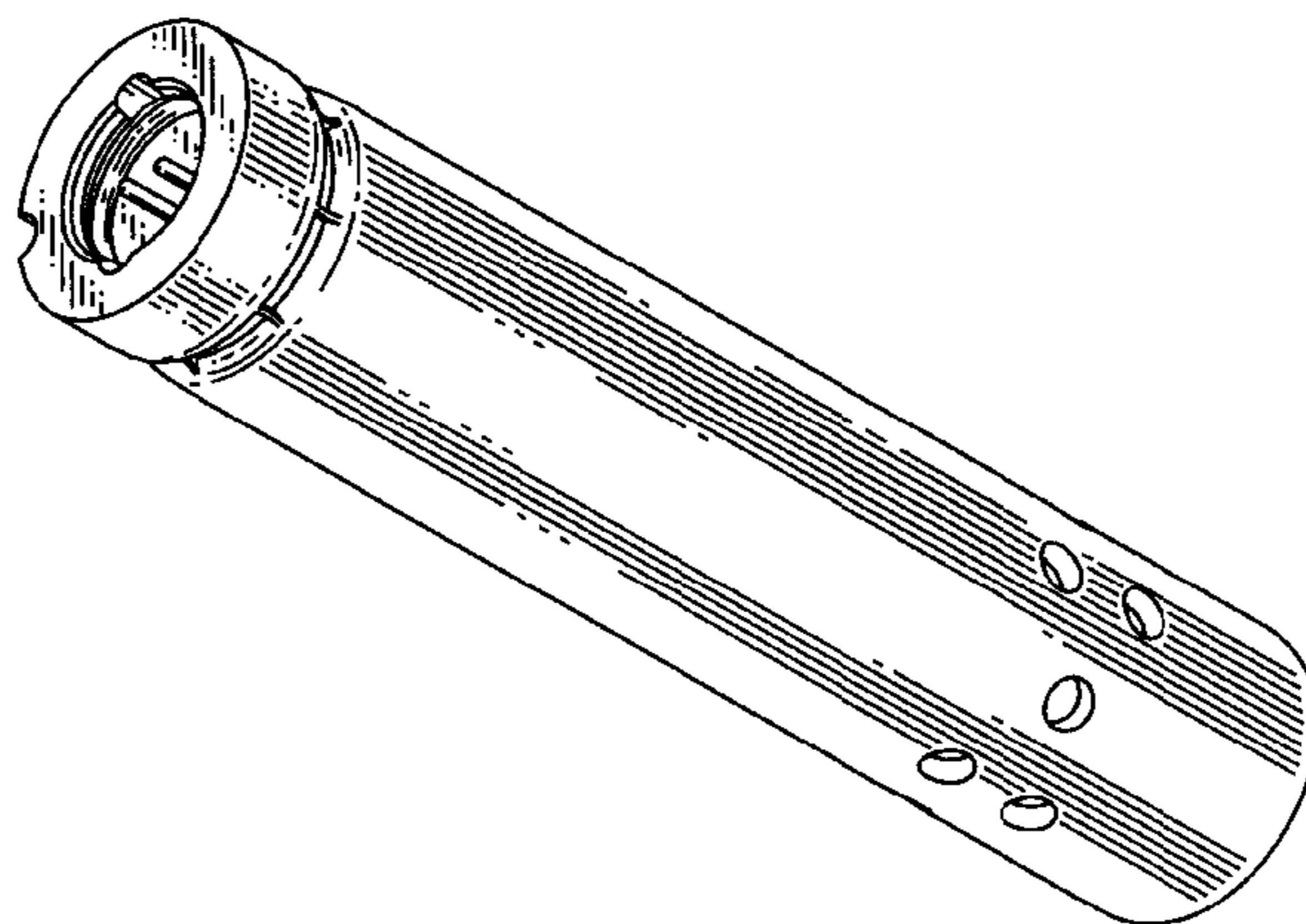

FIG.17

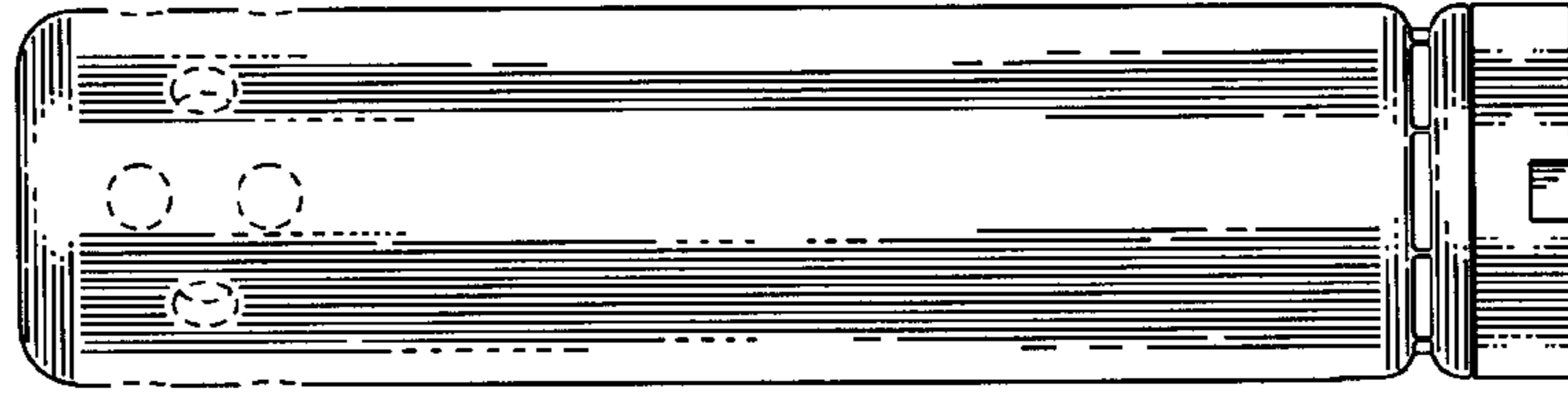

FIG.18

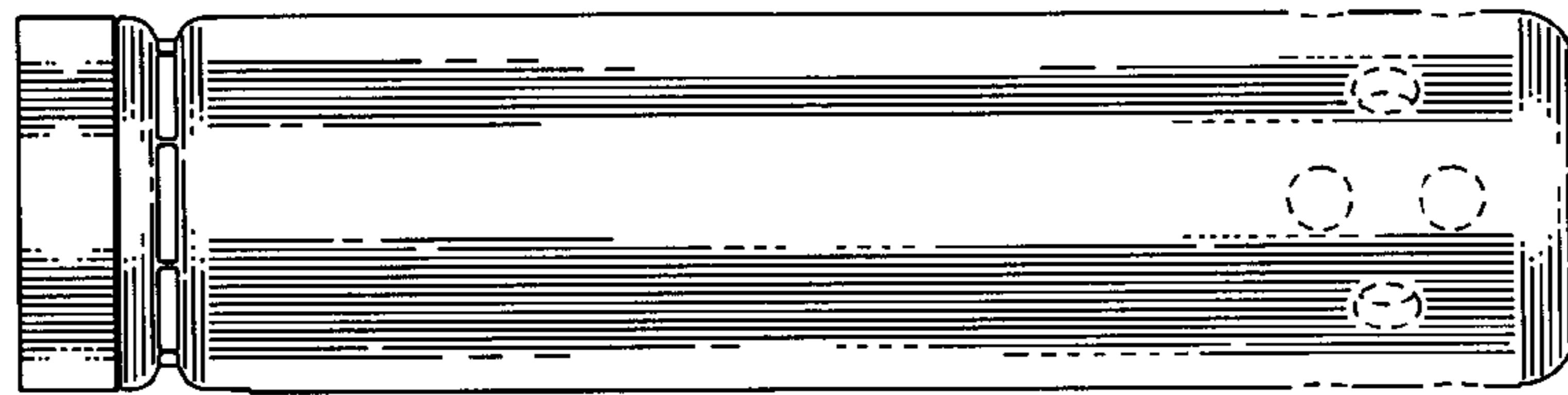

FIG.19

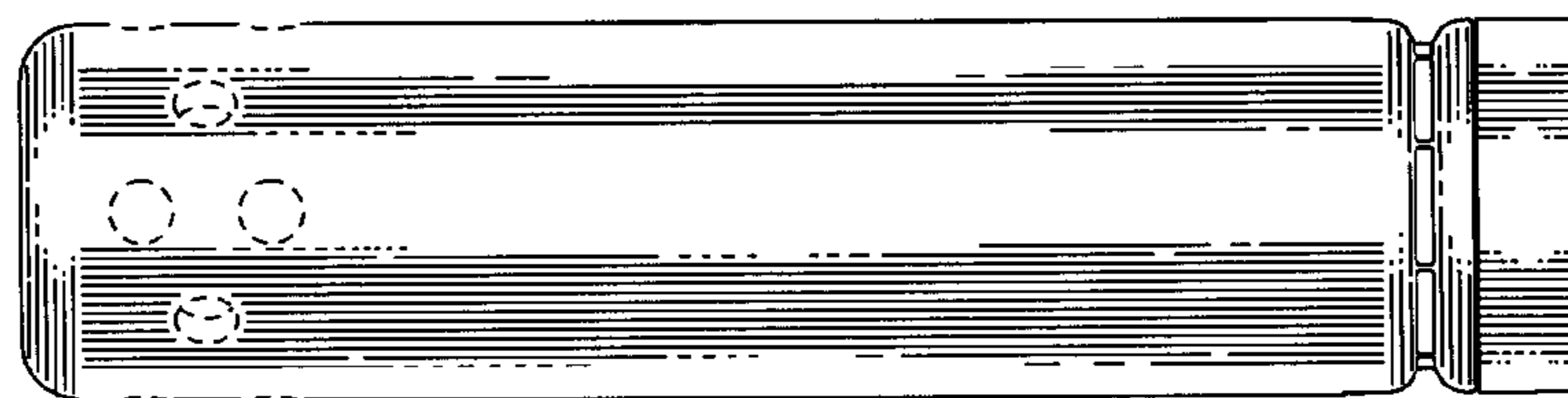

FIG.20

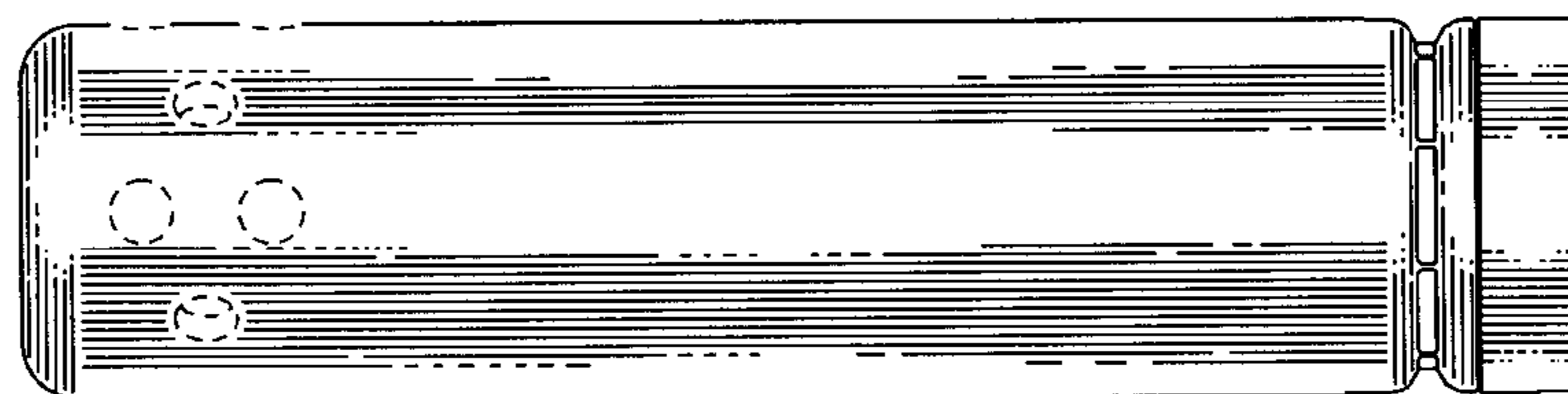

FIG.21

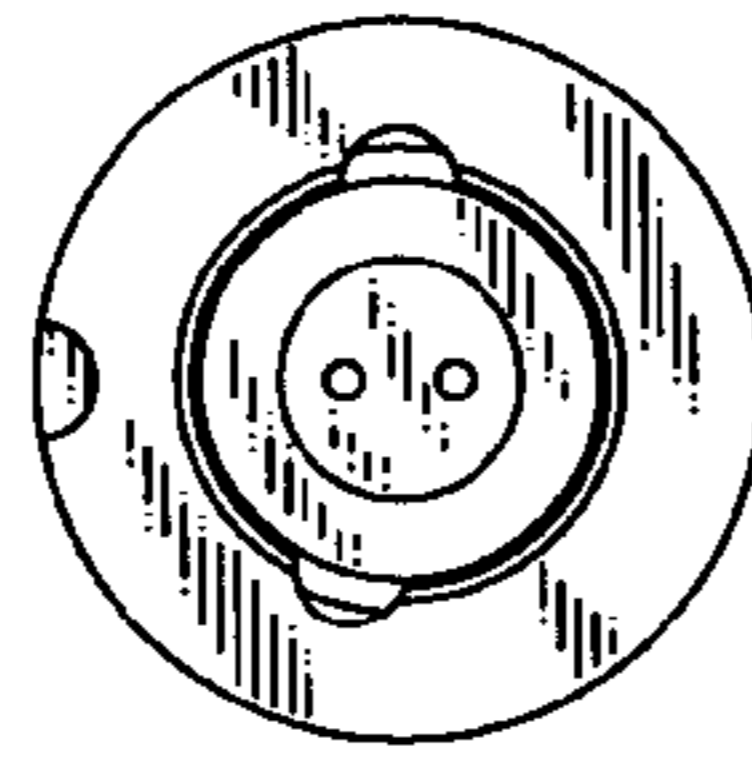

FIG.22

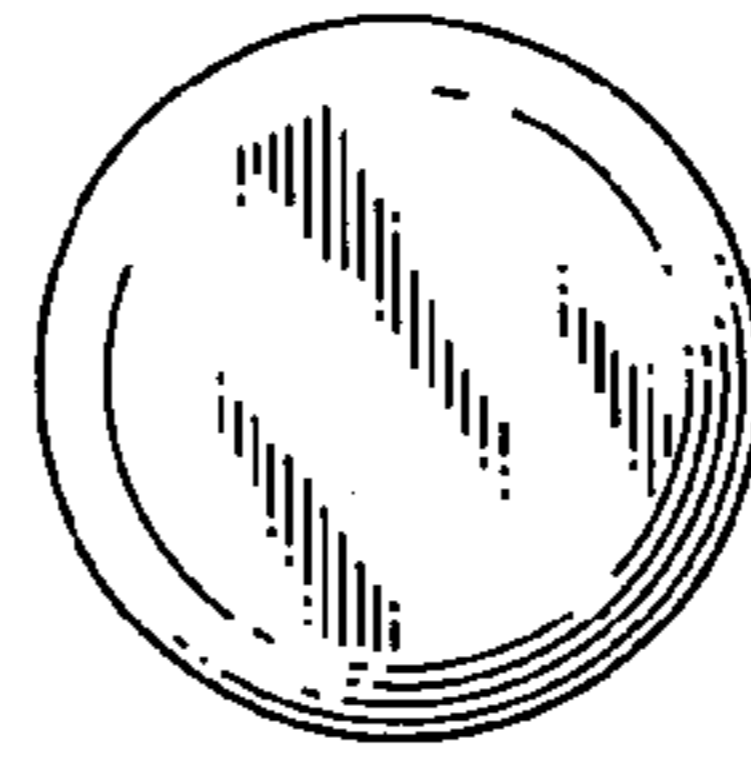

FIG.23

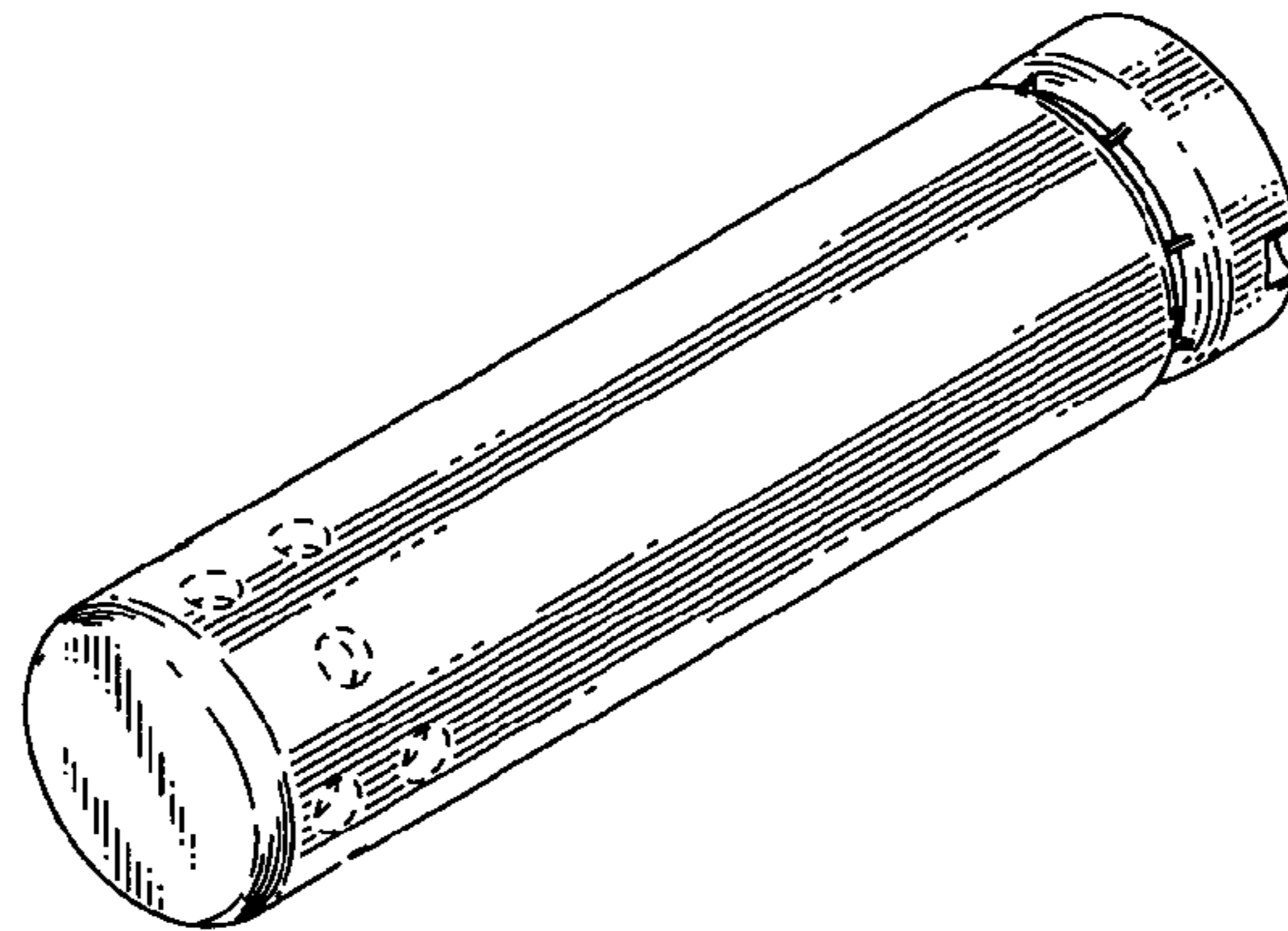

FIG.24

