



US00D643350S

(12) **United States Design Patent**
Furst

(10) **Patent No.:** **US D643,350 S**
(45) **Date of Patent:** **** Aug. 16, 2011**

(54) **VEHICLE FRONT BUMPER UNIT**

DESCRIPTION

- (75) Inventor: **Michael W. Furst**, Venice, CA (US)
- (73) Assignee: **Honda Motor Co., Ltd.**, Tokyo (JP)
- (**) Term: **14 Years**
- (21) Appl. No.: **29/378,123**
- (22) Filed: **Oct. 29, 2010**
- (51) **LOC (9) Cl.** **12-16**
- (52) **U.S. Cl.** **D12/169**
- (58) **Field of Classification Search** D12/169,
D12/196, 171, 216, 163, 86, 90-92; 293/102,
293/113, 115, 117, 120; 296/180.1, 180.2
See application file for complete search history.

(56) **References Cited**

U.S. PATENT DOCUMENTS

| | | | |
|--------------|---------|----------------------|---------|
| D575,696 S * | 8/2008 | Gale et al. | D12/169 |
| D577,317 S * | 9/2008 | Tabata et al. | D12/169 |
| D629,729 S * | 12/2010 | Akasawa et al. | D12/169 |
| D630,978 S * | 1/2011 | Koshino et al. | D12/169 |
| D630,979 S * | 1/2011 | Sperling et al. | D12/169 |

* cited by examiner

Primary Examiner — Melody N Brown

(74) *Attorney, Agent, or Firm* — Plumsea Law Group, LLC;
Mark E. Duell

(57) **CLAIM**

The ornamental design for a vehicle front bumper unit, as shown and described.

The contents of concurrently filed application Ser. No. 29/378,104 is hereby incorporated by reference.

FIG. 1 is a perspective view of a vehicle front bumper unit showing my new design;

FIG. 2 is a front elevational view thereof;

FIG. 3 is a top plan view thereof; and,

FIG. 4 is a side elevational view of one side thereof, the opposite side elevational view being a mirror image.

Inventive aspects of the current embodiments exist in the vehicle as a whole, in individual portions or elements thereof, and in combinations of portions and elements thereof. Applicant reserves the right to amend this application and/or to file one or more divisional applications to specifically claim any such arrangement or any specific embodiment or embodiments.

While the photographic drawings are in black and white, applicants reserve the right to claim or disclaim color contrasts in the present application and in any divisional applications. In some of the photographic drawings, the background shows various contrasts, applicant disclaims any colors, contrasts or textures implied by the backgrounds as these form no part of the claimed design.

Some of the photographic drawings include trademarks and other indicia thereon. Applicant's invention also includes the design without the trademarks and other indicia thereon. Applicant's invention further includes a continuous surface and/or pattern in lieu of the trademarks and/or other indicia. Moreover, the photographic drawings include background images or reflective images on surfaces of the vehicle which form no part of the claimed design.

The logo shown in broken lines inside of the lozenge shape in the center of the bumper unit forms is for illustrative purposes only and form no part of the claimed design.

1 Claim, 4 Drawing Sheets

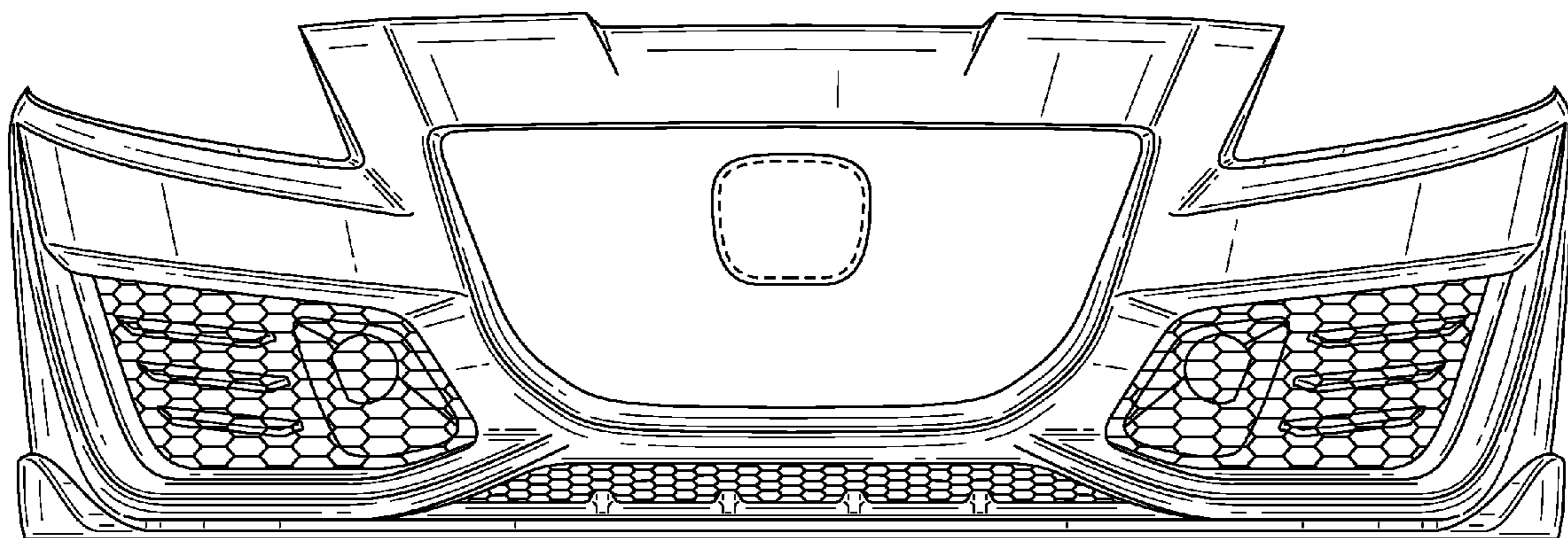

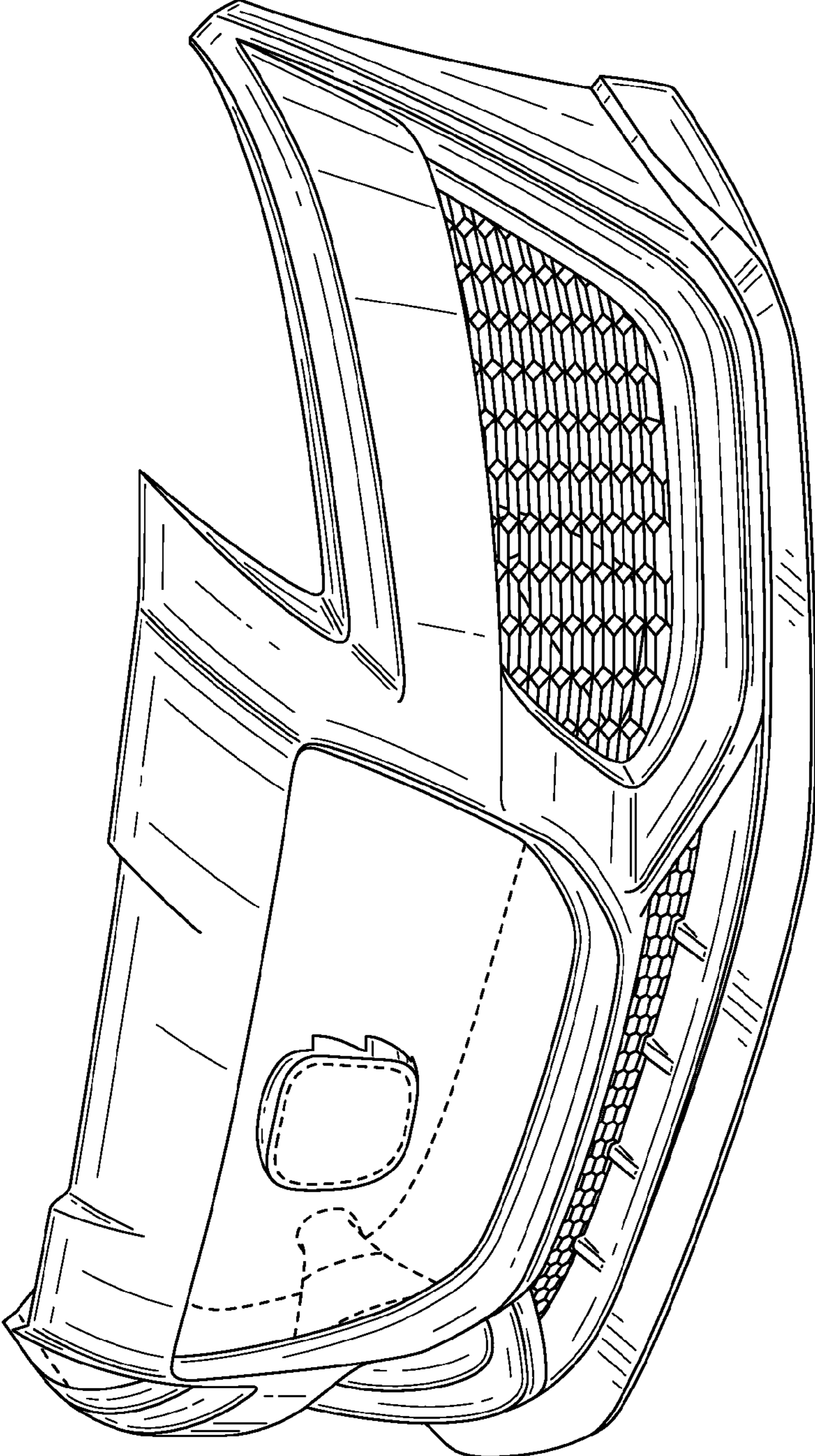

Fig. 1

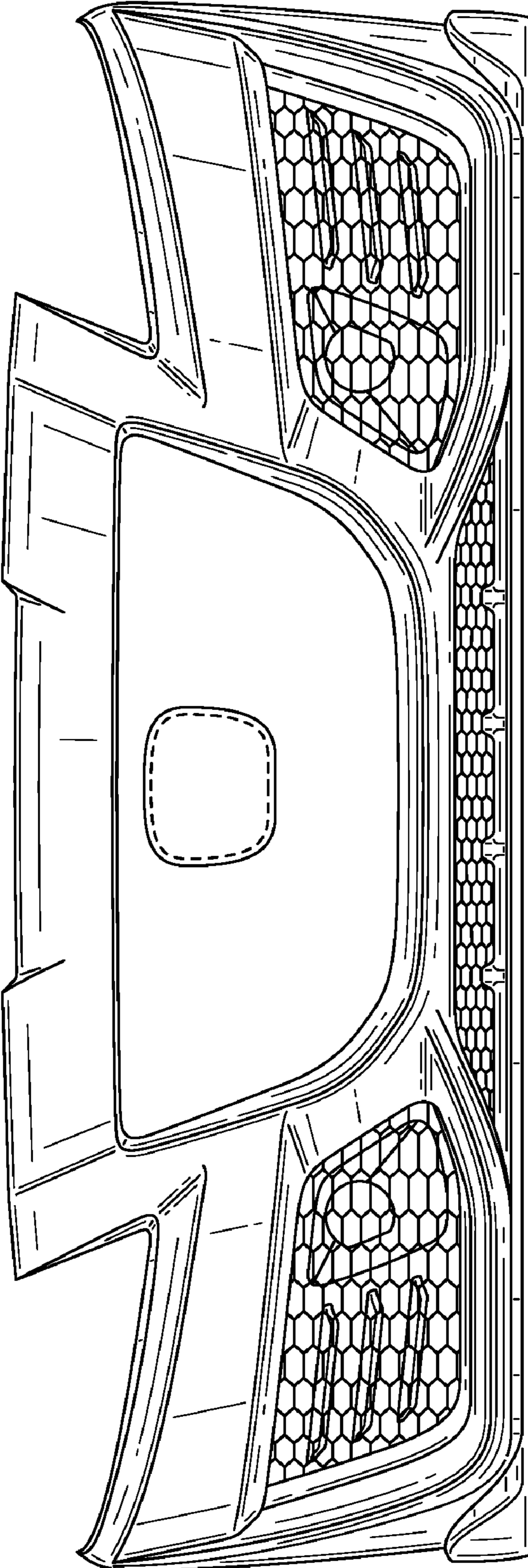

Fig. 2

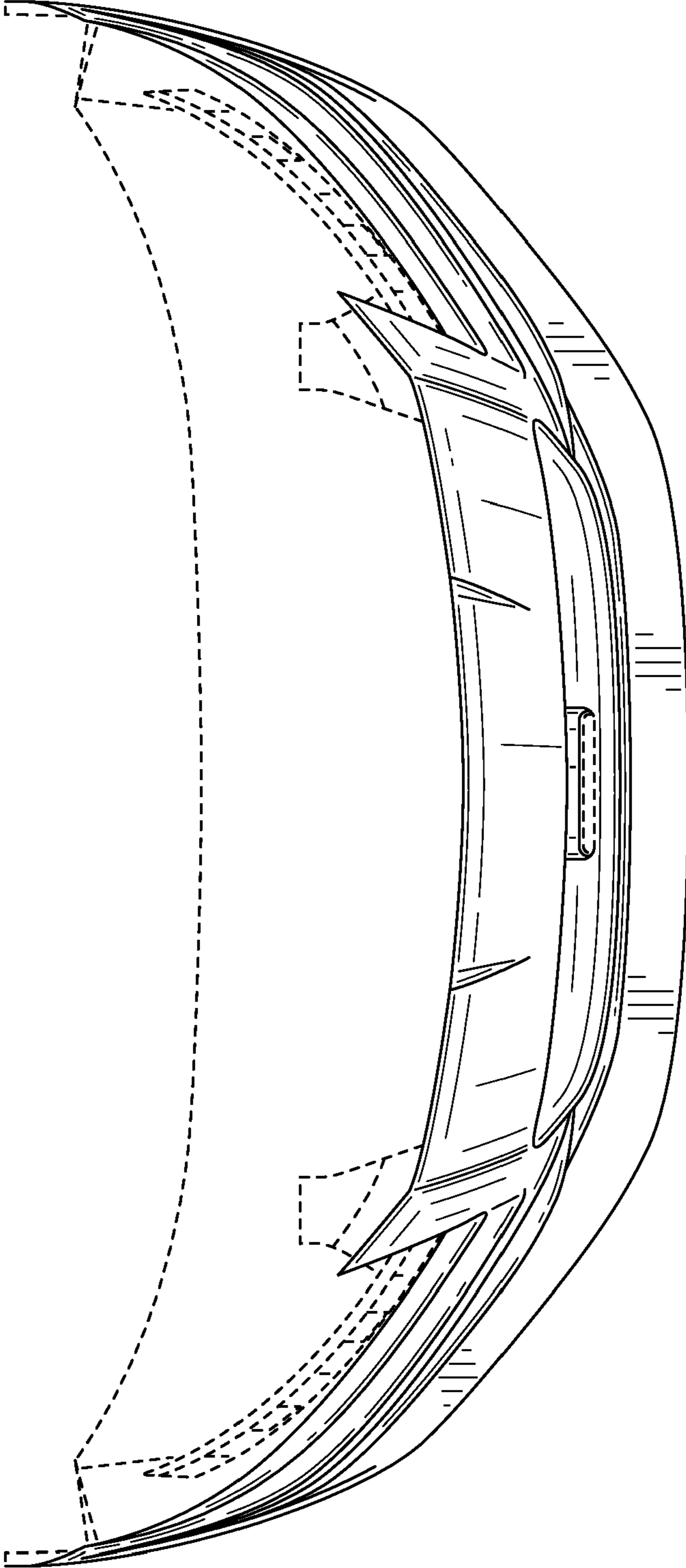

Fig. 3

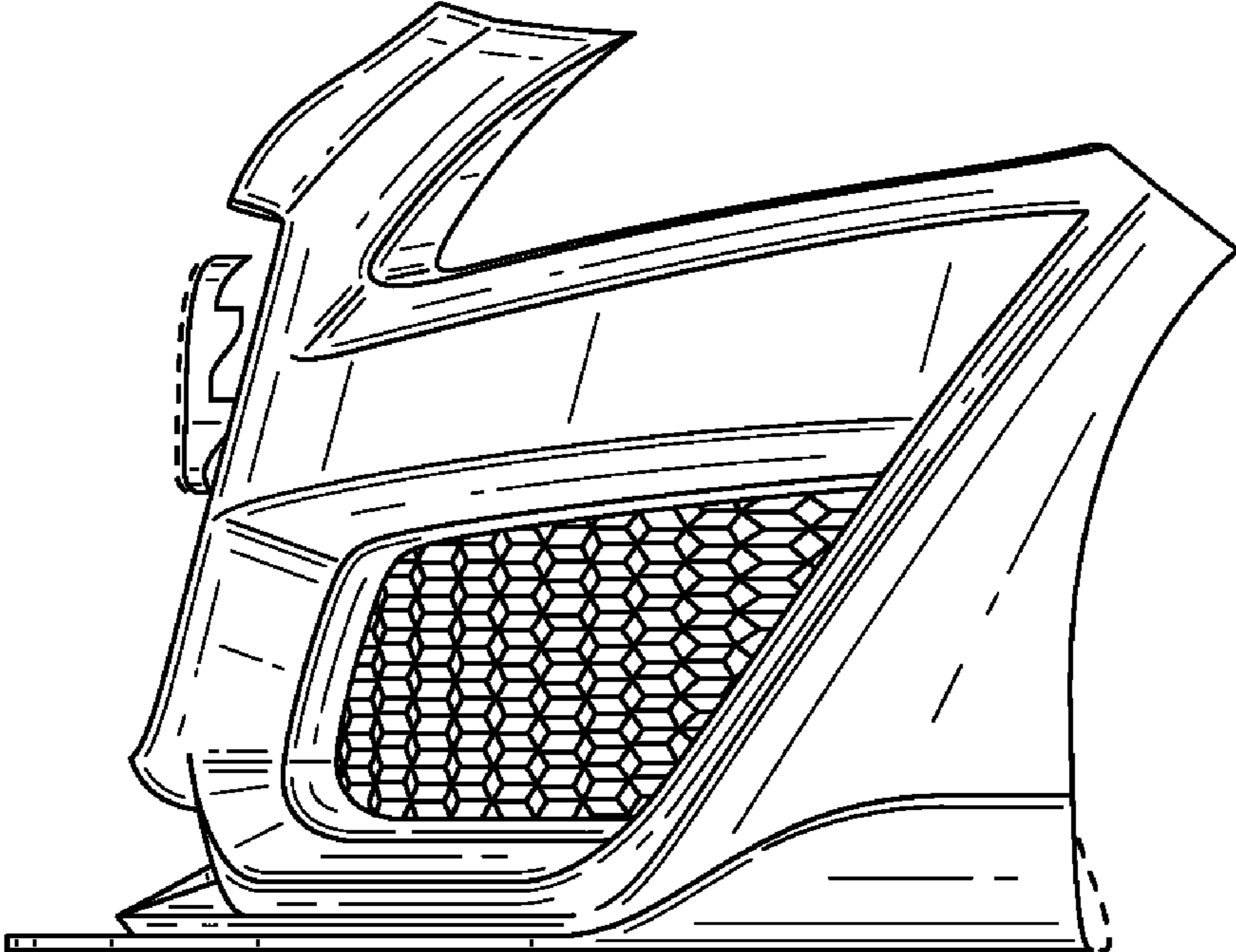

Fig. 4